

fischer 

Catalogue Fixing systems



Foreword

Dear partners,

many topics move the fixing industry. These include changes in construction methods, new and more frequently used building materials, and digitalization. As one of the world's leading companies in the fixing industry, we are therefore looking firmly ahead to continue to provide you with the best and most economical solution for your application. Our innovative strength and technological expertise from more than 70 years flow into the continuous further development of our products and services.

We place particular emphasis on the safety, quality and processing comfort of our products. Our product range includes plastic fixings, steel anchors, chemical systems, embedded fixing solutions such as cast-in elements and much more. We also have a broad range of screws, drills, adhesives, sealants and foams. Assortments tailored to applications, such as façade and thermal insulation composite systems, or sanitary, heating, ventilation and electrical installation complete the program.

With our wide range of services, we support you in all your fixing projects. Our sales representatives and application engineers guarantee personal and professional support. Our 50 companies in 38 countries bring us even closer to our customers. With our FiXperience design software and data for software applications (BIM, 3D), we support you in project planning.

Digital services, such as our plug finder apps, simplify the selection and use of our products. With a wide range of online and face-to-face training courses from our fischer Academy, you can always stay up to date with the latest fixing solutions and regulations.

We hope you enjoy discovering and using our products!



Armin Heß

Speaker of the Management Board Fixing Systems and Managing Director Sales and Marketing of the fischer group of companies



„Whoever chooses fischer receives more than a range of safe products. The aim is to always develop the best solutions for our customers across the globe.“

Besides the innovative products, this predominantly concerns support that is focused on the customer, and services designed to improve customer benefit.

A brand and its promise to perform.

Continious improvement

The fischer ProzessSystem (fPS) we ensure that we readapting and optimising our processes in line with customer requirements in a fl exible manner and on a continuous basis. Thus we are glad having been awarded with the 1. place “Excellence in Operations” within the challenging contest “Factory of the Year”.



Award 2015
Excellence in
Operations

Safety that connects. Decisive quality

We don't make any compromises when it comes to the safety of our products. A whole host of our products are distinguished by comprehensive, up-to-date and international approvals. The fischer product range is well-positioned in all sectors of fixing technology – Steel, Nylon and Chemical fixings. In awardwinning quality which continues to impress both professional clients and private customers with equal measure.



See ICC-ES
Evaluation Report
at www.icc-es.org



International approvals characterise many of our products.

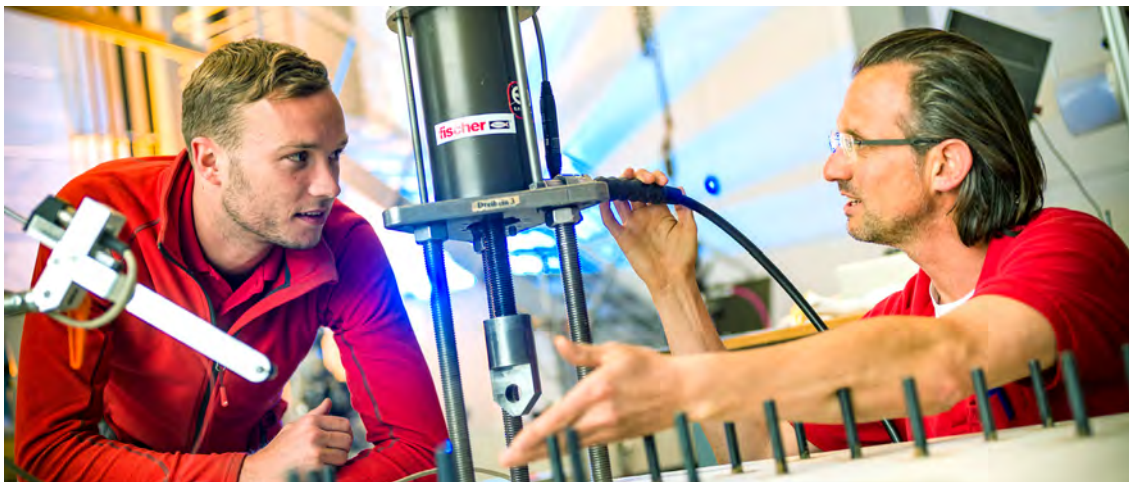



Always on the pulse of time

At fischer, innovation is more than just a sum of the patents. We are open to new things and are prepared for change – always with the aim of offering our customers the greatest possible benefits. Over the years, our own development and production sites have been developing numerous fixing solutions for the most wide-ranging applications. Be it new production procedures or materials, such as renewable raw materials: We are carrying out the research for your safety and will continue to do so in the future. This gives us such great flexibility that we can even develop tailor-made customer solutions. This power to innovate has seen fischer become market leader in anchor technology and the fixing industry.

Our service to you

We are a reliable partner, one that will stand at your side and address your individual requirements with advice and action:

- Our products range from **chemical systems to steel anchors** through to plastic anchors.
- **Competence and innovation** through own research, development and production.
- **Global presence** and active sales service in over 100 countries.
- **Qualified technical consulting** for economical and compliant fastening solutions. Also on-site at the construction site requested.
- **Training sessions**, some with accreditation, at your premises or at the fischer academy.
- **Design and construction software** for demanding applications.

We take responsibility

Our active environment management policy means that we are helping to maintain an intact environment for our generation and for those that follow. The environment management policy at the Tumlingen site has been certified in line with DIN EN ISO 14001. It fills us with particular pride that in 2020 we have received the most important and largest award in Europe in the field of sustainability: the German Sustainability Award - category large companies. This was in recognition of our holistic approach and the strategic anchoring of our sustainability management. With our greenline products we have launched the first range of fixings on the market that is based on renewable raw materials to more than 50%.



Greenline assortment based on 50% regrowing raw materials



German Sustainability Award

Innovations to inspire professionals.



01 fischer bolt anchor FAZ II

For highest demands. Powerful and flexible.

Page 198

03 fischer adjusting washer FSW 10

To easily install wooden beams and timber sleepers.

Page 230

05 fischer injection mortar FIS V Plus

The powerful universal mortar for concrete and masonry.

Page 90

02 fischer concrete screw UltraCut FBS II 8-14

The high-performance concrete screw for absolute installation ease.

Page 224

04 fischer gas actuated fastening tool FGC 100

Quick and easy fastening in concrete and steel.

Page 638

06 fischer DuoLine assortment

Clever combinations for more power and intelligence.

Page 366

Page 436







Page 362

Page 422

Content













Selection guide of products and applications	8	1
Greenline	25	2
Chemical fixings	53	3
High performance steel anchors	197	4
Frame fixings / Stand-off installation	303	5
General fixings	361	6
Cavity fixings	421	7
Electrical fixings	449	8
Sanitary fixings	495	9
Scaffold and eye screw fixings	509	10
Insulation fixings / Façade fixings	521	11
Foams and sealants	553	12
Adhesives	595	13
Drills and bits	605	14
Power tools	631	15
Basic knowledge of fastening technology	642	16
Service	666	17

2 GreenLine



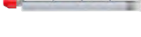



Universal plug UX Green	28	
Expansion plug SX Green	31	
Plasterboard fixing GK Green	34	
Hammerfix N Green	36	
Aircrete anchor GB Green	38	
Insulation fixing FID Green	40	
Injection mortar FIS Green	42	

3 Chemical fixings











MORTARS AND CAPSULES FOR GENERAL APPLICATIONS





















Highbond-System FHB II	54	
Highbond-System FHB II Inject	62	
Superbond-System FSB	67	
Resin anchor RM II	75	
Epoxy mortar FIS EM Plus	79	
Epoxy mortar FIS EB	84	
Epoxy mortar FIS EP	87	
Injection mortar FIS V Plus	90	
Injection mortar FIS V	99	
Injection mortar FIS VL	107	
Injection mortar FIS Green	113	
Injection mortar FIS P Plus	119	
Injection mortar FIS P	123	

ANCHOR RODS





Threaded rod FIS A	128	
Threaded rod RG M	137	
Internal-threaded anchor RG M I	142	
Internal threaded sockets FIS E	144	
Accessories for push-through installation	147	
Injection anchor sleeves	149	

SPECIAL APPLICATIONS

Highbond anchor dynamic FHB dyn	153	
Superbond dynamic FSB dyn	158	
Dynamic-Anchor FDA	167	
Rebar connections	170	
Concrete-Concrete Shear Connector FCC	177	
Remedial wall tie VBS 8	179	
Weather facing reconstruction system FWS II	181	
Can System FCS	184	
Fill & Fix injection fixing	186	
Dispenser	189	
Accessories	194	

















Concrete screw UltraCut FBS II 8-14	224	
Concrete screw UltraCut FBS II 6	234	
Concrete screw FBS N	239	
Hammerset anchor EA II	242	
Hammerset anchor EA Plus	247	
Hammerset anchor EA-N	250	
Nail anchor FNA II	254	
Nail anchor FNA II RB	259	
Ceiling nail FDN II	263	
Ceiling nail FDZ	266	
Bolt anchor FBN II	269	
Bolt anchor FXA	275	
Bolt anchor FWA	277	
Heavy-duty anchor TA M	281	
Heavy-duty anchor TA M-T	285	
Sleeve anchor FSA	288	
Fixing set for diamond drills FDBB	291	
Wall screw MR	293	
Hollow-ceiling anchor FHY	295	
Aircrete anchor FPX-I	298	

4 High performance steel anchors

Bolt anchor FAZ II	198	
High performance anchor FH II	205	
High performance anchor FH II-I	211	
ZYKON undercut anchor FZA	214	
ZYKON hammerset anchor FZEA II	221	





















5

Frame fixings / Stand-off installation

Frame fixing SXRL	304	
Frame fixing SXR	310	
Frame fixing FUR	316	
Anti-corrosion spray FTC-CP	321	
Hammerfix N	322	
Hammerfix N Green	326	
Nail sleeve FNH	328	
Window frame fixing F-S	330	
Metal frame fixing F-M	333	
Window frame screws FFSZ and FFS	336	
Adjustable fixing S10J	340	
Adjustable screw JUSS	342	
Spacing screw ASL	344	
Stand-off installation TherMax 8/10	346	
Stand-off installation TherMax 12/16	350	
Remedial wall tie mechanical VBS-M	356	







6

General fixings

DuoPower	362	
DuoSeal	366	
Universal plug UX	369	
Universal plug UX Green	374	
Expansion plug SX	377	
Expansion plug SX Green	381	
Expansion plug S	384	
Threaded rod plug RodForce FGD	387	
Metal expansion anchor FMD	390	
Expansion plug M-S	392	
Anchor M	394	
Brass fixing MS	396	
Aircrete anchor GB	398	
Aircrete anchor GB Green	401	
Turbo aircrete anchor FTP K	404	
Turbo aircrete anchor FTP M	407	
Brass fixing PA 4	410	
Balcony cladding fixing P 9 K	412	
Stair-tread fixing TB / TBB	414	
Repair pad FixIt	416	
Doorstop TS	418	





















7

Cavity fixings

Nylon toggle DuoTec	422	
Metal cavity fixing HM	426	
Spring-toggle KD, KDH, KM	430	
Board fixing PD	434	
Plasterboard fixing DuoBlade	436	
Plasterboard fixing GK	439	
Plasterboard fixing GK Green	442	
Plasterboard fixing metal GKM	445	





8

Electrical fixings

Locking clip SCN	450	
Pipe clip RC	452	
Pipe clip FC	454	
Saddle clip SCH	456	
Fastening tie FF	458	
ClipFix plus LS/ES/ZS	460	
ClipFix plus SD	462	
Cable clasp KB	464	
Cable harness SHA	466	
Multi cable support metal SHA M	468	
Wall slot clip FWSC	470	
Nail disc NSB	472	
Nail clip NS/MNS	474	
Spacer pipe clamp AM/AMD	476	
Conduit clip BSM	479	
Textile web strapping GWB	481	
Perforated steel banding LBV / LBK	483	
Impact nail ED	485	
Cable tie BN/GBN/UBN	487	
Cable tie plug FCTP	489	
Wireclip WIC	491	





9

Sanitary fixings

Sanitary fixings for board materials	496	
Ceramic fixings	499	
Washbasin fixing WST Klik	502	
Wash basin and urinal fixings	504	















10

Scaffold and eye screw fixings

Scaffold anchoring GS 12 + plug	510	
Scaffold anchoring FI G	513	
Eye screw GS	515	
Ring nut RI	518	





























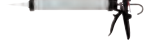

11

Insulation fixings/ Façade fixings

Insulation support DHK	522	
Insulation support DHM	524	
Render fixing DIPK	527	
Render fixing FIF-PN 8	529	
Render fixing FIF-CN II 8	532	
Render fixing FIF-CS 8	535	
Insulation discs DT	538	
Insulation discs	539	
TermoFix H	541	
Retaining disc with screw DHT S	542	
Insulation fixing FID	544	
Insulation fixing FID-R	546	
Insulation fixing FID Green	548	
Holding clamp DVN	550	





12

Foams and sealants

1c premium installation foam PU 500/750	554		Roof and wall silicone DBSI	581	
1c rapid installation foam PU S 500/750 B2	555		Premium silicone 1 For All DNS	582	
1c premium flex foam PUP FLEX 750 B2	556		Premium B1 silicone DFS	583	
1c premium gun foam PUP 750 B2	558		Premium painting acrylic DMA	584	
1c premium gun foam compact PUP 500 B2	559		Premium structured acrylic DSA	585	
1c gun foam PUP S 750 B2	560		Acrylic sealant DA	586	
1c maxi gun foam PUP S 500 B2	561		Repair mortar DEC	587	
1c premium gun foam PUP 750 B3	562		Premium all-weather sealant DDK	588	
1c premium gun foam PUP B1 750	563		Roof sealing compound DD	589	
1c premium gun foam PUP BS 750 B2	564		Accessories for sealants	590	
1c perimeter adhesive foam PUP P 750	565		Zinc spray FTC-ZS	592	
1c adhesive foam PUP ETICS 750	566		Zinc-alu spray FTC-ZA	593	
2c premium rapid foam 2K PU 400 Plus	567				
Accessories	568				
Sealant selection matrix	570				
Premium sanitary silicone DSSA	574				
Sanitary silicone DSSI	576				
Multi-silicone DMS	577				
Premium high temperature silicone DHS	578				
Premium construction silicone DBSA	579				















13

Adhesives

Assembly adhesive MK	596	
Power adhesive express KK	597	
Multi Adhesive & Sealant KD	598	
Multi Adhesive & Sealant Crystal KDC	600	
High Tack Flex-Adhesive HTM	601	



14

Drills and bits

Hammer drill bit Quattric II	606	
Hammer drill bit SDS Plus II Pointer	610	
Masonry drill bit Pointer M	614	
Hammer drill bit SDS Max II / SDS Max IV	615	
Hollow drill bit FHD	618	
Stone drill bit D-S	620	
Premium chisel FCP	621	
Standard chisel	622	
ProfiBit FPB	623	
DiamondBit FDB	624	
MaxxBit FMB	625	
BitHolder FBH	626	
BitSet	627	
Accessories for impact driver	628	

15







Power tools

Cordless impact wrenches FSS 18V	632	
Vacuum cleaner FVC 35M	635	
Gas actuated fastening tool FGC 100	638	

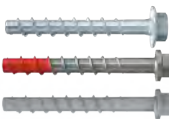

Non-cracked concrete

Product		Type	Single fixings for non-cracked concrete		
			Chemical systems		
		Page Image	Epoxy mortar-system FIS EM Plus 79	Superbond-System FSB 67	Injection mortar FIS V / FIS V PLUS 90
Connection thread or Screw diameter	Anchor rod or anchor size		M8 – M30	M8 – M30	M6 – M30
	Internal thread		M8 – M20	M8 – M20	M8 – M20
	Reinforcing bar		Ø 8 – 40 mm	Ø 8 – 32 mm	Ø 8 – 28 mm
	Screw diameter		–	–	–
Steel/material	gvz		•	•	•
	R		•	•	•
	HCR		•	•	•
	HDG/CP		–	–	–
	Nylon		–	–	–
Usable length	up to		∞	∞	∞
Approvals / Certificates	Approvals	ETA	•	•	•
		ICC	•	•	•
		DiBt	–	–	–
		Seismic	•	•	•
		Dynamic	–	–	–
	Certificates	Shock	–	–	–
		Fire resistance reports	•	•	•
Type of installation	Pre-positioned installation		•	•	•
	Push-through installation		•	•	•
	Stand-off installation		•	•	•
Drilling method	Hammer drilling		•	•	•
	Hollow drilling		•	•	•
	Diamond-drilling		•	•	–
Waiting time until loading at 20 °C	none		–	–	–
	short	< 5 Minutes	–	–	–
	middle	≤ 20 Minutes	–	•	•
	long	> 20 Minutes	•	•	•
Substrate			-5 °C	-30 °C	-10 °C
Special features	approved without borehole cleaning		–	–	–
	Installation in concrete < C20/25 acc. certificate		–	–	–
	Installation in concrete > C50/60 acc. certificate		–	–	–
	approved in water-filled drill holes		•	•	•
	Installation in steel fibre concrete possible		•	•	•
	Installation possible in narrow members ≤ 120 mm		•	•	•
	removable	flush with the surface	•*	•*	•*
	completely	–	–	–	







Single fixings for non-cracked concrete				Redundant fixtures (multiple fixtures)		
Steel anchors				Steel anchors		Frame fixings
Bolt anchor FAZ II 198	Bolt anchor FBN II 269	Concrete Screw FBS II 224	High performance anchor FH II 205	Nail anchor FNA II 254	Drop-in anchor EA II 242	SXR / SXRL 304
						
M6 – M24	M6 – M20	Ø 6 – 14 mm	Ø 10 – 32 mm	Ø 6 mm M6 – M8	–	Ø 8 – 14 mm
•	–	–	M6 – M12	–	M6 – M12	–
–	–	–	–	–	–	–
–	–	–	–	–	–	Ø 6 – 10 mm
•	•	•	•	•	•	•
•	•	•	•	•	•	•
•	–	–	–	•	–	–
–	•	•	–	–	–	–
–	–	–	–	–	–	•
300 mm	300 mm	205 mm	100 mm	120 mm	∞	290 mm
•	•	•	•	•	•	•
•	–	–	•	–	–	–
–	–	–	–	–	–	•
•	–	(•)*	•	–	–	–
–	–	–	–	–	–	–
•	–	–	•	–	–	–
•	•	–	•*	–	•	–
•	•	•	•	•	–	•
•	•	–	•*	–	•	–
•	•	•	•	•	•	•
•	•	•	•	–	–	–
•	–	•	–	–	–	–
•	•	•	•	•	•	•
–	–	–	–	–	–	–
–	–	–	–	–	–	–
–40 °C	–40 °C	–40 °C	–40 °C	–40 °C	–40 °C	–40 °C
–	–	•	–	–	–	–
•	–	–	–	–	–	–
•	–	–	–	–	–	–
•	•	•	•	•	•	–
–	–	–	–	–	–	–
•	•	•	•	•	•	•
–	–	•	•*	–	•	•
–	–	•	–	–	–	•

* With internal threaded anchor

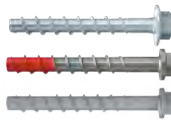



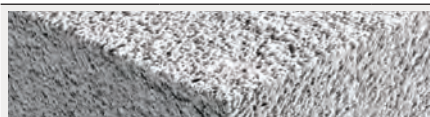

Cracked concrete

Product		Single fixings for cracked concrete				
		Chemical systems				
Type		Highbond-System FHB II	Epoxy mortar-system FIS EM Plus	Superbond-System FSB	Injection mortar FIS V/FIS V PLUS	
Page		54	79	67	90	
Image						
Connection thread or Screw diameter	Anchor rod or anchor size	M8 – M24	M8 – M30	M8 – M30	M8 – M30	
	Internal thread	–	M8 – M20	M 8 – M 20	–	
	Reinforcing bar	–	Ø 8 – 40 mm	Ø 8 – 32 mm	Ø 10 – 28 mm	
	Screw diameter	–	–	–	–	
Steel/material	gvz	•	•	•	•	
	R	•	•	•	•	
	HCR	•	•	•	•	
	HDG/CP	–	–	–	–	
	Nylon	–	–	–	–	
Usable length	up to	165 mm	∞	∞	∞	
Approvals / Certificates	Approvals	ETA	•	•	•	•
		ICC	–	•	•	•
		DiBt	–	–	–	–
		Seismic	–	•	•	•
		Dynamic	–	–	–	–
	Certificates	Shock	•	–	–	–
Fire resistance reports		•	•	•	•	
Type of installation	Pre-positioned installation	•	•	•	•	
	Push-through installation	•	•	•	•	
	Stand-off installation	•	•	•	•	
Drilling method	Hammer drilling	•	•	•	•	
	Hollow drilling	•	•	•	•	
	Diamond-drilling	–	•	•	–	
Waiting time until loading at 20 °C	none	–	–	–	–	
	short	< 5 Minutes	•	–	–	
	middle	≤ 20 Minutes	•	–	•	
	long	> 20 Minutes	–	•	•	
Substrate		-5 °C	+5 °C	-30 °C	-10 °C	
Special features	approved without drill-hole cleaning	•	–	–	–	
	Installation in concrete < C20/25 acc. certificate	•	–	•	•	
	Installation in concrete > C50/60 acc. certificate	•	–	•	•	
	approved in water-filled drill holes	•	•	•	•	
	Installation in steel fibre concrete possible	•	•	•	•	
	Installation possible in narrow members ≤ 120 mm	•	•	•	•	
	removable	flush with the surface	–	•*	•*	–
	completely	–	–	–	–	

Single fixings for cracked concrete			Redundant fixtures (multiple fixtures)			
Steel anchors			Frame fixings	Steel anchors		Frame fixings
Bolt anchor FAZ II	Concrete Screw FBS II	High performance anchor FH II	SXRL 10	Nail anchor FNA II	Drop-in anchor EA II	SXR / SXRL
198	224	205	304	254	250	304
						
M6 – M24	Ø 6 – 14 mm	Ø 10 – 32 mm	Ø 10 mm	Ø 6 mm M6 – M8	–	Ø 8 – 14 mm
–	–	M6 – M12	–	–	M6 – M12	–
–	–	–	–	–	–	–
–	–	–	7 mm	–	–	Ø 6 – 10 mm
•	•	•	•	•	•	•
•	•	•	•	•	•	•
•	–	–	–	•	–	–
–	•	–	–	–	–	–
–	–	–	•	–	–	•
300 mm	205 mm	100 mm	220 mm	120 mm	∞	290 mm
•	•	•	–	•	•	•
•	–	•	–	–	–	–
–	–	–	•	–	–	•
•	(•)*	•	–	–	–	–
–	–	–	–	–	–	–
•	–	•	–	–	–	–
•	•	•	–	•	•	–
•	–	•*	–	•	•	–
•	•	•	•	•	–	•
•	–	•*	–	–	•	–
•	•	•	•	•	•	•
•	•	–	–	–	–	–
•	•	–	–	–	–	–
•	•	•	•	•	•	•
–	–	–	–	–	–	–
–	–	–	–	–	–	–
–40 °C	–40 °C	–40 °C	–40 °C	–40 °C	–40 °C	–40 °C
–	•	–	–	–	–	–
•	•	–	–	•	•	–
•	–	–	–	–	–	–
•	•	•	•	•	•	–
–	–	–	–	–	–	–
•	–	–	–	•	•	•
–	•	•*	•	–	•	•
–	•	–	•	–	–	•

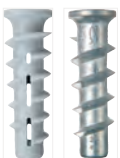

Aircrete concrete

Product	Type	Chemical systems	Steel-anchor	Frame fixings	General fixings		
		Injection mortar FIS V/FIS V PLUS	Aircrete anchor FPX-I	SXRL	Aircrete anchor GB	DuoPower	Turbo aircrete anchor FTP K/M
Page	Image	90	298	304	398	362	404
							
Connection thread or Screw diameter	Anchor rod or anchor size	M6 – M16	–	Ø 8 – 14 mm	GB 10	Ø 5 – 14 mm	Ø 4 – 10 mm
	Internal thread	M6 – M12	M6 – M12	–	–	–	M6 – M10
	Screw diameter	–	–	Ø 6 – 10 mm	Ø 5 – 10 mm	Ø 3 – 12 mm	Ø 5 – 10 mm
Steel/material	gvz	•	•	•	–	–	•
	R	•	–	•	–	–	–
	Nylon	–	–	•	•	•	•
Usable length	up to	∞	∞	290 mm	105 mm	∞	∞
Approvals / Certificates	Approvals	•	•	•	–	–	–
	Certificates	•	•	–	•	–	–
Type of installation	Pre-positioned installation	•	•	–	•	•	•
	Push-through installation	•	–	•	–	•	–
	Stand-off installation	•	•	–	–	–	–
Drilling method	Hammer drilling	•	–	•	–	–	–
	Rotary drilling	•	•	•	•	•	•
Waiting time until loading at 20 °C	none	–	•	•	•	•	•
	short	–	–	–	–	–	–
	middle	•	–	–	–	–	–
	long	•	–	–	–	–	–
Minimum component temperature		-10 °C	-40 °C	-40 °C	-20 °C	-40 °C	-40 °C
Special features	approved without borehole cleaning	–	–	–	–	–	–
	applicable in aircrete concrete ceilings	–	•	–	–	–	–
	removable	•*	•	•	•	•	•
		–	–	•	•	•	•







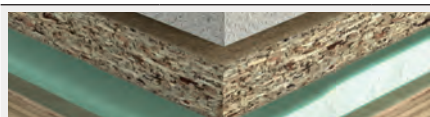

Solid & perforated brick

Product	Type	Page Image	Chemical systems	Frame fixings			General fixings
			Injection mortar FIS V/FIS V PLUS 90	SXR 310	SXRL 304	Nail plug N 322	DuoPower 362
Connection thread or Screw diameter	Anchor rod or anchor size		M6 – M16	Ø 6–10 mm	Ø 8 – 14 mm	Ø 5–10 mm	Ø 5–14 mm
	Internal thread		M6 – M12	–	–	–	–
	Screw diameter		–	Ø 6 – 7 mm	Ø 6 – 10 mm	3,5 – 7 mm	Ø 3 – 12 mm
Steel/material	gvz		•	•	•	•	–
	R		•	•	•	in A2	–
	Nylon		–	•	•	•	•
Usable length	up to		∞	210 mm	290 mm	180 mm	∞
Approvals / Certificates	Approvals	ETA	•	•	•	–	–
		DiBt	–	–	•	–	–
	Certificates	Fire resistance reports	•	–	–	–	–
Type of installation	Pre-positioned installation		•	–	–	–	•
	Push-through installation		•	•	•	•	•
	Stand-off installation		•	–	–	–	–
Drilling method	Hammer drilling		•	•	•	•	•
	Rotary drilling		•	•	•	•	•
Waiting time until loading at 20 °C	none		–	•	•	•	•
	short	< 5 Minutes	–	–	–	–	–
	middle	≤ 20 Minutes	•	–	–	–	–
	long	> 20 Minutes	•	–	–	–	–
Minimum component temperature			-10 °C	-40 °C	-40 °C	-40 °C	-40 °C
Special features	approved without borehole cleaning		–	–	–	–	–
	removable	flush with the surface	•*	•	•	•	•
		completely	–	•	•	•	•

* With internal threaded anchor



Panel building materials

Product	Type	Page Image	Cavity fixings				General fixings	
			Metal cavity fixing HM 426	Gravity toggle/spring toggle KD 430	DuoTec 422	Board fixing PD 434	Plasterboard fixing DuoBlade 436	DuoPower 362
								
Connection thread or diameter of the screw	anchor size		M4 – M8	M3 – M10	Ø 10 and Ø 12 mm	Ø 8 – 12 mm	–	Ø 5,6,8 and 10 mm
	Screw diameter		Metric Screw M4 – M6; Hexagon-headed screw M8; Angle hook M4 and M5	Metric thread M3 – M10; Round hook M3 – M8	Metric thread M5 – M6 Chipboard screws 4,5 – 6 mm	Chipboard screw 4,0 – 6,0 mm	Chipboard screw 4,0 – 5,0 mm	Chipboard screw 3,0 – 8,0 mm
Steel/material	gvz		•	•	–	–	–	–
	R		–	–	–	–	–	–
	Nylon		–	–	•	•	•	•
Panel thickness			3 – 50 mm	9,5 – 90 mm	9,5 – 55 mm	min. 6 mm	min. 9,5 mm	min. 9,5 mm
Usable length	up to		34 mm	63 mm	∞	∞	∞	∞
	required cavity depth by 12,5 mm board thickness		min. 19 mm	min. 27 mm	min. 40 mm	min. 23 mm	min. 35 mm	min. 18 mm
Type of installation	Pre-positioned installation		•	•	•	•	•	•
	Push-through installation		–	–	–	–	–	•
	Stand-off installation		–	•	•	–	–	–
Drilling method	Rotary drilling		•	•	•	•	•	•
Waiting time until loading	none		•	•	•	•	•	•
Special features	removable	flush with the surface	•	•	•	–	–	–
		completely	–	–	–	•	•	•









Insulated building materials (e.g. ETICS)

Product	Type	Page	Stand-off installation system		Insulation fixing FID
			Image	TherMax 12 and 16 337	TherMax 8 and 10 334
Connection thread or Screw diameter	Anchor rod or anchor size		M12 and M16	M8 and M10	-
	Screw diameter		-	4,5 - 6 mm, M6 - M10	4,5 - 6 mm
Steel/material	gvz		•	•	•
	R		•	-	-
	Nylon		-	•	-
Usable length	up to		170 and 290 mm	180 and 240 mm	∞
Approvals / Certificates	Approvals	ETA	-	-	-
		DiBt	•	-	-
Type of installation	Pre-positioned installation		•	•	•
	Push-through installation		-	-	-
	Stand-off installation		•	•	-
Drilling method	Hammer drilling		•	•	-
	Rotary drilling		•	-	-
Waiting time until loading at 20°C	none		-	•	•
	short	< 5 Minutes	depends on the injection mortar	-	-
	middle	≤ 20 Minutes	depends on the injection mortar	-	-
	long	> 20 Minutes	depends on the injection mortar	-	-
Minimum component temperature			depends on the injection mortar	-40 °C	-40 °C
Special features	removable	flush with the surface	•	•	•
		completely	-	-	•



2

GreenLine

Universal plug UX GREEN	28	
Expansion plug SX GREEN	31	
Plasterboard fixing GK GREEN	34	
Hammerfix N GREEN	36	
Aircrete anchor GB GREEN	38	
Insulation fixing FID GREEN	40	
Injection mortar FIS GREEN	42	

Environmentally friendly and secure.

2

Sustainable building



With the introduction of its greenline products, fischer is the first manufacturer worldwide to offer a range of bio-based fixing systems.

We are adapting to the demands of processors and builders who greatly value sustainability when building and renovating, even when it comes to installation.

Grown naturally



All greenline products are produced with at least 50 % renewable raw materials. These do not compete with food and feed products or with corresponding cultivation areas. The regenerative material percentage is always confirmed by independent testing and certification by the DIN CERTCO / TÜV Rheinland. All products are in the „BIOBASED 50 - 85%“ class.

Durably secure



We do not make any compromises when it comes to the security of greenline products. They have the same features and load-bearing capacity as the grey coloured originals. Just 100% fischer nylon quality - made in Germany!

Ecological proof of performance

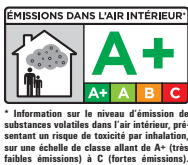

The FIS Green has been classified in the best possible emission class: A+ „very low emission“ for volatile substances as per the French VOC directive. Ecological advantages that also pay dividends in competition.

We take responsibility



For decades fischer has been actively practising environmental protection and taking on responsibility so that the environment remains intact for future generations.

We have an environmental management system certified according to DIN ISO 14001 and are a member of the German Sustainable Building Council (DGNB).

The first range of fixing products with renewable resources.

General fixings

Universal plug UX Green
The nylon plug for all construction materials 28 

Chemical fixings

Injection mortar FIS Green 300 T
Injection mortar for high loads 42 

Special fixings

Expansion plug SX Green
The powerful nylon plug with 4-way expansion 31 















Plasterboard fixing GK Green
The fastest installation in gypsum plasterboard 34 

Hammerfix N Green
The hammer-in plug for simple, fast and economic installation 36 

Aircrete anchor GB Green
Secure in aerated concrete 38 

Insulation fixing FID Green
Thermal bridgefree installation in insulation materials 40 

The fischer greenline product line has a green solution for every building material.

greenline range								
	Concrete	Solid brick	Perforated brick	Aerated concrete	Natural stone	Panel building materials	Gypsum plasterboard	Insulation panels
 UX Green	•	•	•	•	•	•	•	–
 SX Green	•	•	•	•	•	–	–	–
 GK Green	–	–	–	–	–	–	•	–
 N Green	•	•	•	•	•	–	–	–
 GB Green	–	–	–	•	–	–	–	–
 FID Green	–	–	–	–	–	–	–	•
 FIS Green	•	•	•	•	•	–	–	–

Universal plug UX Green

The nylon plug for all building materials



2



Mirror fixings



Pictures

Applications

- Pictures
- Lighting
- Skirting
- Light cabinets
- Towel rails
- Mirror cabinets
- Curtain rails
- Wash basin fixings
- TV consoles
- Plumbing and heating fixings

Advantages

- Produced with at least 50% renewable raw materials and therefore particularly environmentally friendly.
- Just as effective, secure and durable as regular UX plugs.
- The universal operating principle (knotting or expanding) allows for use in all solid,

hollow and board building materials. Thus the UX Green is the correct choice for unknown base materials.

- Plug collar for anti-slip safety and saw tooth sides as turning lock ensure the highest installation safety.

Certificates



Building materials

- Concrete
- Gypsum plasterboard and gypsum fibreboards
- Vertically perforated brick
- Hollow blocks made from lightweight concrete
- Cavity floor slabs made from bricks and concrete
- Perforated sand-lime brick
- Solid sand-lime brick
- Natural stone
- Aerated concrete
- Chipboard
- Solid panel made from gypsum
- Solid brick made from lightweight concrete
- Solid brick

Functioning

- The Universal plug UX with rim is suitable for pre-positioned installation; the UX without rim is suitable for push-through installation.
- When screwing in the screw, the UX GREEN expands in solid building materials and knots itself into cavities.
- Suitable for wood and chipboard screws, as well as stud screws.
- The required screw length is given by: the plug length + fixture thickness + 1 x screw diameter.
- In the case of board building materials, the threadless part of the screw must not be longer than the fixture.
- The edge distance must be at least one plug length.

Installation UX Green

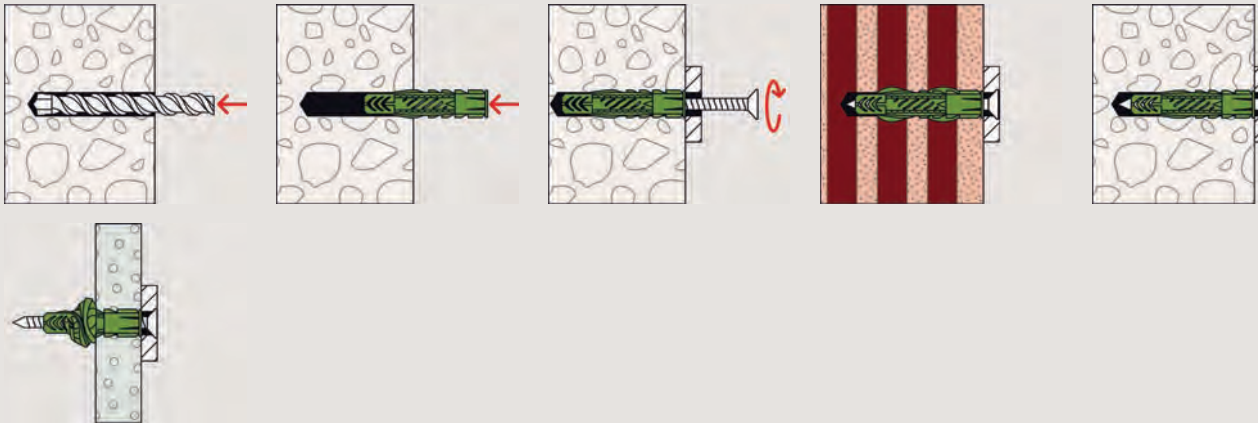

2

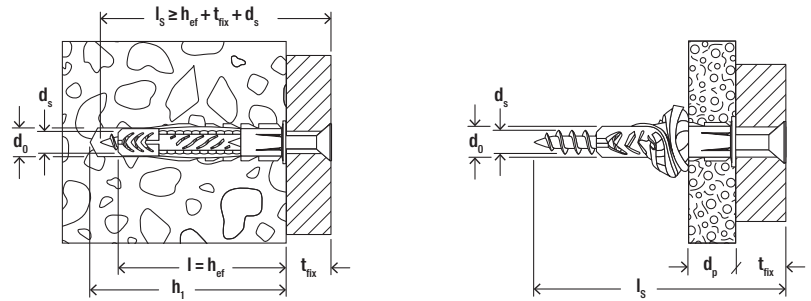

Technical data

Universal plug UX Green

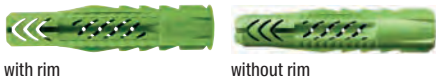

with rim

without rim

Item	With rim	Without rim	Drill hole diameter d_0 [mm]	Min. drill hole depth h_1 [mm]	Min. panel thickness d_p [mm]	Anchor length l [mm]	Wood and chip-board screws $d_s / d_s \times l_s$ [mm]	Sales unit [pcs]
	Item No. UX R	Item No. UX						
UX Green 6 x 35	518885	—	6	45	9,5	35	4 - 5	40
UX Green 6 x 50	524855	—	6	60	9,5	50	4 - 5	40
UX Green 8 x 50	518886	—	8	60	9,5	50	4,5 - 6	40
UX Green 10 x 60	518887	—	10	75	12,5	60	6 - 8	20
UX Green 12 x 70	—	524858	12	85	—	70	8 - 10	18

Loads

Universal plug UX Green

Highest recommended loads¹⁾ for a single anchor.

The given loads are valid for wood screws with the specified diameter.

Type		UX Green 6 x 35	UX Green 6 x 50	UX Green 8 x 50	UX Green 10 x 60	UX Green 12 x 70	
Screw diameter	[mm]	5	5	6	8	10	
Recommended loads in the respective base material $F_{rec}^{2)}$							
Concrete	≥ C20/25	[kN]	0.40	0.60	0.60	1.00	1.50
Solid brick	≥ Mz 12	[kN]	0.20	0.30	0.30	0.50	0.70
Perforated sand-lime brick	≥ KSL 12	[kN]	0.40	0.40	0.50	0.60	0.80
Vertically perforated brick	≥ Hlz 12	[kN]	0.20	0.20	0.20	0.20	0.30
Aerated concrete	≥ AAC 4 (G4)	[kN]	0.20	0.20	0.30	0.40	0.60
Gypsum plasterboard	12.5 mm	[kN]	0.10	0.10	0.10	0.10	-
Gypsum plasterboard	25 mm	[kN]	0.15	0.15	0.15	0.15	-
Gypsum fibreboard	(Fermacell)	[kN]	0.20	0.20	0.20	0.25	-
Gypsum block	$\rho \geq 0.9 \text{ kg/dm}^3$	[kN]	-	-	0.15	0.35	0.45

¹⁾ Required safety factors are considered.

²⁾ Valid for tensile load, shear load and oblique load under any angle.

Expansion plug SX Green

The powerful nylon plug with 4-way expansion

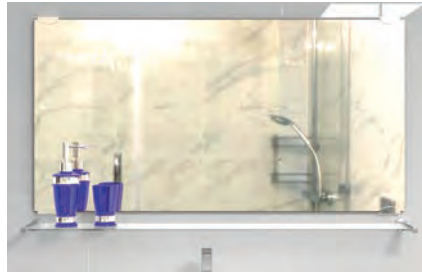

Mirror fixings



Wall consoles

2

Applications

- Lighting
- Wardrobes
- Motion detectors
- Skirting
- Light shelves
- Mirror cabinets
- Letter boxes
- TV consoles
- Trellis
- Folding shutters
- Bath and toilet installations

Certificates



Advantages

- Produced with at least 50% renewable raw materials and therefore particularly environmentally friendly.
- Just as effective, secure and durable as regular SX plugs.
- The powerful 4-way expansion provides optimum force transmission in the building material, thus enabling high load values and security.
- The anti-rotation lock prevents the plug

- from spinning in the drill hole.
- The expansion-free plug neck prevents the creation of expansion forces on the material whilst screwing in the screw. This helps to prevent damage to tiles and plaster.
- Fast and easy push-through installation reduces installation time.

Building materials

- Concrete
- Vertically perforated brick
- Hollow blocks made from lightweight concrete
- Cavity floor slabs made from bricks and concrete or similar
- Perforated sand-lime brick
- Solid sand-lime brick
- Natural stone with dense structure
- Aerated concrete
- Solid panel made from gypsum
- Solid brick made from lightweight concrete
- Solid brick

Functioning

- The SX GREEN is suitable for pre-positioned and push-through installation.
- When screwing in the screw, the SX GREEN expands in four directions, thus providing a secure anchoring in the building material.
- The required screw length is given by the plug length + fixture thickness + 1 x screw diameter.
- Suitable for wood, chipboard and spacing screws.

Installation SX Green

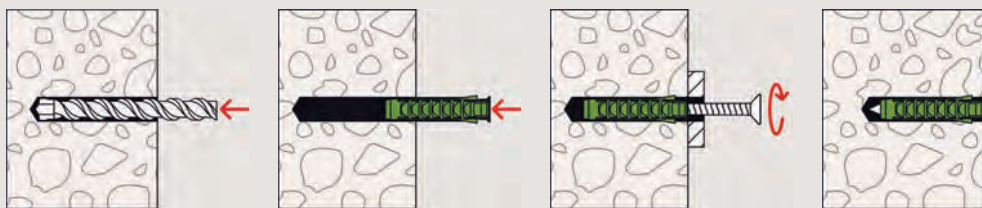

2

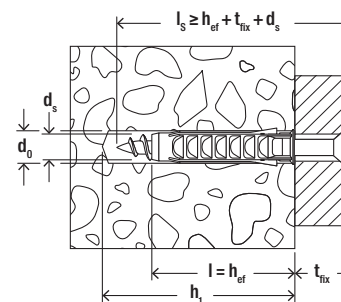

Technical data

Expansion plug SX Green

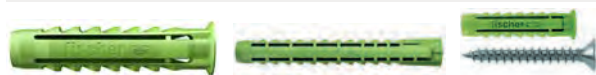

with rim

with greater anchorage depth, without rim

with rim and screw

Item	With rim	Without rim and large anchorage depth	With rim and screw	Drill hole diameter	Min. drill hole depth	Anchor length	Max. fixture thickness	Wood and chip-board screws	Sales unit
	Item No. SX	Item No. SX	Item No. SX-S	d_0 [mm]	h_1 [mm]	l [mm]	t_{fix} [mm]	$d_s / d_s \times l_s$ [mm]	[pcs]
SX Green 5 x 25	524859	—	—	5	35	25	—	3 - 4	90
SX Green 6 x 30	524860	—	—	6	40	30	—	4 - 5	90
SX Green 6 x 30	—	—	524866	6	45	30	5	4,5 x 40	45
SX Green 6 x 50	—	524861	—	6	60	50	—	4 - 5	90
SX Green 8 x 40	524862	—	—	8	50	40	—	4,5 - 6	90
SX Green 8 x 40	—	—	524867	8	60	40	15	5 x 55	45
SX Green 8 x 65	—	524863	—	8	75	65	—	4,5 - 6	45
SX Green 10 x 50	524864	—	—	10	60	50	—	6 - 8	45
SX Green 12 x 60	524865	—	—	12	80	60	—	8 - 10	20

Loads

Expansion plug SX Green

Highest recommended loads¹⁾ for a single anchor.

The given loads are valid for wood screws with the specified diameter.

Type		SX Green 5 x 25	SX Green 6 x 30 SX Green 6 x 50	SX Green 8 x 40 SX Green 8 x 65	SX Green 10 x 50	SX Green 12 x 60	
Wood screw diameter	[mm]	4	5	6	8	10	
Min. edge distance concrete c_{min}	[mm]	25	35	40	50	65	
Recommended loads in the respective base material F_{rec} ²⁾							
Concrete	≥ C20/25	[kN]	0.30	0.65	0.70	1.20	1.70
Solid brick	≥ Mz 12	[kN]	0.25	0.30	0.60	0.65	0.70
Solid sand-lime brick	≥ KS 12	[kN]	0.30	0.50	0.60	1.20	1.70
Aerated concrete	≥ AAC 2 (G2)	[kN]	0.03	0.03	0.04	0.09	0.14
Aerated concrete	≥ AAC 4 (G4)	[kN]	0.09	0.09	0.14	0.30	0.45
Vertically perforated brick	≥ Hlz 12 ($\rho \geq 1.0 \text{ kg/dm}^3$)	[kN]	0.07	0.07	0.17	0.17	0.26
Perforated sand-lime brick	≥ KSL 12	[kN]	0.17	0.30	0.35	0.30	0.35
Gypsum block		[kN]	-	-	0.26	0.37	1.00

¹⁾ Required safety factors are considered.

²⁾ Valid for tensile load, shear load and oblique load under any angle.

Plasterboard fixing GK Green

The fastest installation in gypsum plasterboard



2



Wall lamps



Pictures

Applications

- Pictures
- Lighting
- Electrical installations
- Fitting accessories
- Series installations

Advantages

- Produced with at least 50% renewable raw materials and therefore particularly environmentally friendly.
- Just as effective, secure and durable as regular GK plugs.
- The included setting tool combine the functions of drilling and setting fixings for direct and easy installation.
- Sharp, self-tapping thread for a posi-

tive-fit connection with a high load-bearing capacity.

- The cross-drive recess in the head of the fixing means that the GK Green can also easily be screwed out like a screw.
- The GK Green can be used with various screws, hooks and eye screws, making it very versatile in its applications.

Certificates



Building materials

- Gypsum plasterboard, single and double-planked

Functioning

- The gypsum plasterboard fixing GK Green is suitable for pre-positioned installation.
- The GK Green is screwed flush into the gypsum plasterboard using the setting tool provided. Avoid manual and machine-aided overtightening.
- For board thicknesses greater than 15 mm, drill a hole first by using the setting tool.
- Adapted for wood, sheet metal and chipboard screws with a diameter of 4.0 to 5.0 mm.
- Not suitable for gypsum fibreboard and tiled plasterboard.

Installation GK Green

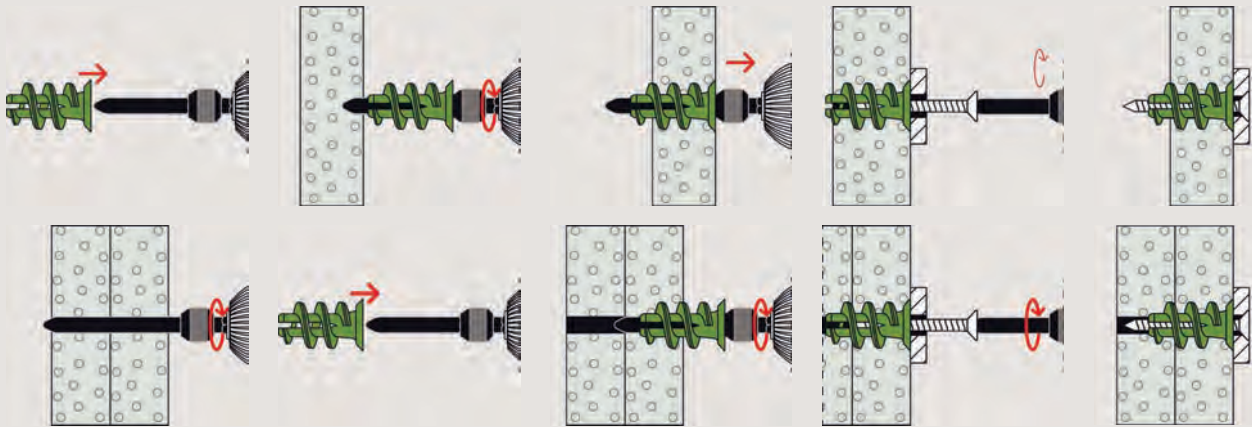

2

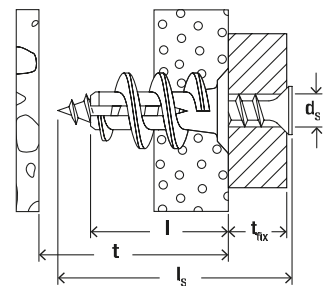

Technical data

Plasterboard fixing GK Green



Item	Item No.	Anchor length l [mm]	Min. thickness to first supporting layer t [mm]	Max. fixture thick- ness t _{fix} [mm]	Screw d _s x l _s [mm]	Drive	Sales unit [pcs]
GK Green	524868 ¹⁾²⁾	22	25	—	4,0 - 5,0 x Ls	—	90
GK Green S	524869 ¹⁾³⁾	22	25	13	4,5 x 35	PZ2	45

1) Including installation tool GKW.

2) Min. screw length = length of plug 22 mm + thickness of building component.

3) Supplied with plasterboard screw.

Loads

Plasterboard fixing GK Green

Recommended loads¹⁾ for a single anchor.

Type		GK
Chipboard screw	[mm]	4.0 - 5.0
Recommended loads in the respective base material F _{rec} ²⁾		
Gypsum plasterboard	9,5 mm	[kN] 0.07
Gypsum plasterboard	12,5 mm	[kN] 0.08
Gypsum plasterboard	2 x 12,5 mm	[kN] 0.11

¹⁾ Required safety factors are considered. The given loads are valid for chipboard screws with the specified diameters.

²⁾ Valid for tensile load, shear load and oblique load under any angle.

Hammerfix N Green

The hammer-in plug for simple, fast and economic installation

2



Cable fixing



Timber substructures

Applications

- Substructures made of wood and metal
- Wall connection or plaster profiles
- Slides
- Sheets
- Cable and pipe clips
- Perforated tapes

Advantages

- Produced with at least 50% renewable raw materials and therefore particularly environmentally friendly.
- Just as effective, secure and durable as regular hammerfix N plugs.
- The rapid push-through and hammer-set installation reduces the amount of work required and allows for economic series

installation.

- The integrated hammer-in stop prevents the plug from expanding prematurely, thus enabling problem-free installation.
- Together with the cross-slot recess, the thread of the nail screw allows the screw to be removed, thus allowing for subsequent dismantling.

Certificates



Building materials

- Concrete
- Solid sand-lime brick
- Building brick
- Natural stone
- Solid brick made from lightweight concrete
- Aerated concrete
- Solid panel made from gypsum
- Vertically perforated brick
- Perforated sand-lime brick
- Hollow blocks made from lightweight concrete

Functioning

- The hammerfix N Green is suitable for push-through installation.
- The easiest installation: drill, knock in and you're done.
- When being hammered in, the nail screw causes the plug to expand in two directions, thus providing a secure anchoring in the building material.

Installation N Green

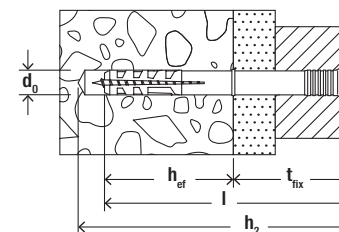
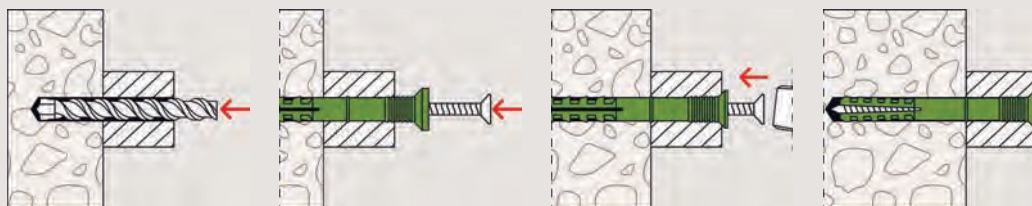

Technical data

Hammerfix N Green



N Green S with countersunk head and zinc-plated nail

Item	Item No.	Drill hole diameter	Effect. anchorage depth	Anchor length	Min. drill hole depth for through fixings	Max. fixture thickness	Drive	Sales unit
		d_0 [mm]	h_{ef} [mm]	l [mm]	h_2 [mm]	t_{fix} [mm]		[pcs]
N Green 6 x 40/10 S	524845	6	30	40	55	10	PZ2	45
N Green 6 x 60/30 S	524847	6	30	60	75	30	PZ2	45
N Green 6 x 80/50 S	524848	6	30	80	95	50	PZ2	45
N Green 8 x 80/40 S	524849	8	40	80	95	40	PZ3	45
N Green 8 x 100/60 S	524850	8	40	100	115	60	PZ3	45

Loads

Hammerfix N Green

Recommended loads¹⁾ for a single anchor.
The given loads are valid for screw nails with the specified diameter.

Type		N Green 6	N Green 8
Screw nail diameter	[mm]	4	5
Recommended loads in the respective base material $F_{rec}^{2)}$			
Concrete	$\geq C20/25$	[kN] 0.25	0.27
Solid brick	$\geq Mz 12$	[kN] 0.18	0.24
Solid sand-lime brick	$\geq KS 12$	[kN] 0.22	0.24
Solid brick of lightweight aggregate concrete	$\geq V 4$	[kN] 0.12	0.15
Aerated concrete	$\geq AAC 2$	[kN] 0.04	0.05
Aerated concrete	$\geq AAC 4$	[kN] 0.10	0.13

¹⁾ Required safety factors are considered.

²⁾ Valid for tensile load, shear load and oblique load under any angle.

Aircrete anchor GB Green

Secure in aerated concrete



Radiators

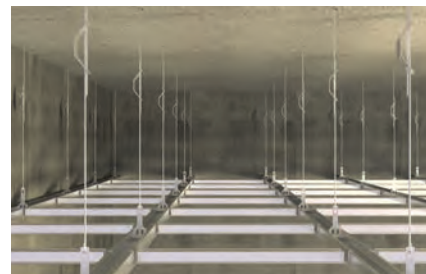

Suspended ceilings

2

Applications

- Suspended ceilings
- Cable trays
- Pipelines
- Guard rails
- Façade and roof constructions made of wood and metal
- Anopy brackets
- Letter boxes
- Trellis

Advantages

- Produced with at least 50% renewable raw materials and therefore particularly environmentally friendly.
- The spiral-shaped outer ribs cut a positive fit in the soft building material, thus

ensuring best pressure distribution and load-bearing capacity.

- Can be applied with a hammer – there is no need for special tools, thus saving time and money for the installation.

Certificates



Building materials

Suitable for:

- Aerated concrete \geq AAC 2
- Aerated concrete and ceiling panels of compressive strength \geq 3.3

Functioning

- The aircrete anchor GB Green is suitable for pre-positioned installation.
- The spiral-shaped outer ribs cut a positive fit into the soft building material when knocked in, thus ensuring optimal pressure distribution and load-bearing capacity.
- The required screw length is given by the plug length + fixture thickness + 1 x screw diameter.
- Rotary drilling of the hole is required.
- Can be used in unplastered aerated concrete.

Installation GB Green

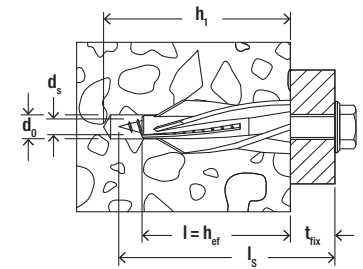
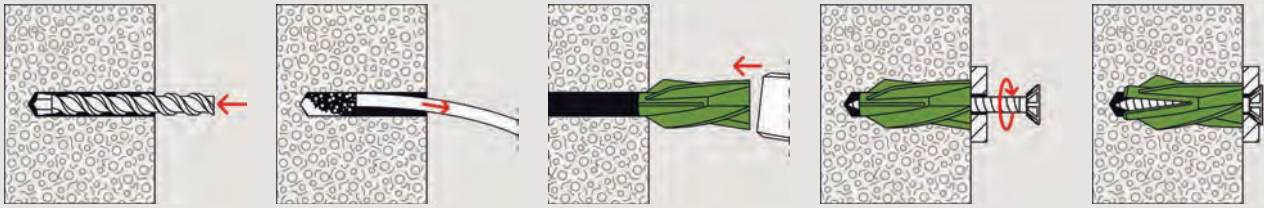

Technical data

Aircrete anchor GB Green



GB Green

Item	Item No.	Drill hole diameter	Min. drill hole depth	Plug length = min. anchorage depth	fischer safety screw	Sales unit
		d_0 [mm]	h_1 [mm]	$l = h_{ef}$ [mm]	$d_s \times l_s$ [mm]	[pcs]
GB Green 8	524870	8	60	50	5	20
GB Green 10	524871	10	65	55	7	18

Loads

Aircrete anchor GB Green

Recommended loads¹⁾ for a single anchor in aerated concrete.
Load values apply when using fischer safety screws²⁾ according to selection table.

Type			GB Green 8	GB Green 10
Diameter fischer safety screw		[mm]	5	7
Minimum spacing ³⁾	s_{min}	[mm]	150 (100) ⁵⁾	100
Minimum edge distance ⁴⁾	c_{min}	[mm]	100 (75) ⁵⁾	100
Minimum member thickness	h_{min}	[mm]	75	120
Nominal embedment depth	h_{nom}	[mm]	50	55
Recommended load (F_{red}) in the respective base material				
AAC 2	$\rho \geq 0,35$ [kg/dm ³]	[kN]	0.18	0.21
AAC 4	$\rho \geq 0,50$ [kg/dm ³]	[kN]	0.40	0.54 (0,71) ⁶⁾

¹⁾ Required safety factors are considered. Valid for tension load, shear load and oblique load under any angle.

²⁾ Galvanised steel (gvz) and stainless steel (R).

³⁾ Minimum possible axial spacing while reducing the permissible load.

⁴⁾ Minimum possible edge distance.

⁵⁾ Values in brackets apply to AAC 2.

⁶⁾ The values in brackets are decisive for member thickness ≥ 150 mm.

Insulation fixing FID Green

Thermal bridge-free installation in insulation materials

2



External lighting



Letterbox

Applications

To fix lightweight attachments on ETICS façades.

The application areas are ETICS façades made of:

- Polystyrene
- Mineral wool
- Soft wood fibre
- Alternative ecological insulation

Advantages

- Produced with at least 50% renewable raw materials and therefore particularly environmentally friendly.
- Just as effective, secure and durable as regular FID plugs. To fix lightweight fixtures in plastered and non-plastered

- insulating boards.
- Thermal bridge-free mounting when exclusively set in insulation material.
- Installation without pre-drilling even through thin plaster layers, thus saving a work step.
- Easy to set using a standard bit.

Certificates



Building materials

- Non-plastered, pressure-resistant insulating boards
- Plastered, pressure-resistant insulating boards
- ETICS insulating boards

Functioning

- The FID GREEN can be set in pre-positioned installation with a cordless screwdriver or by hand.
- With its strong drill tip, the insulation fixing FID GREEN breaks through thin plaster layers and cuts a positive fit into the insulation panel with its specially shaped spiral thread.
- From a plaster thickness of 5 mm, we recommend to create a 6 mm hole. This serves for better guidance of the fastener in the setting process.
- Water ingress in the insulation material can be prevented by sealing the plug collar after successful installation.
- Attachment parts can be easily attached with screws.
- We recommend to predrill an 6 mm hole in ETICS rendering.

Installation FID Green

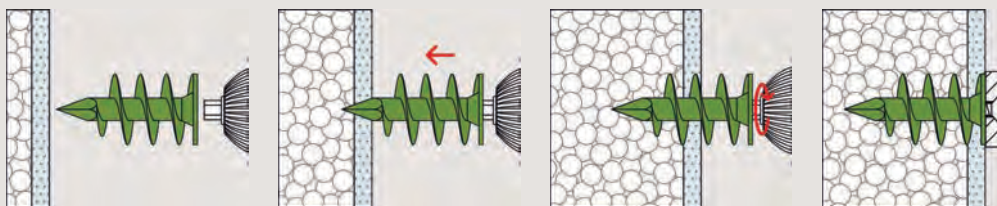

Technical data

Insulation fixing FID Green



FID Green 50



FID Green 90

Item	Item No.	Anchor length l [mm]	Min. bolt penetration [mm]	Wood and chipboard screws d _s [mm]	Drive	Sales unit [pcs]
FID Green 50	524851	50	50	4,5 - 5	T40	45
FID Green 90	524852	90	90	6	Inbus 6 mm	20

Loads

Insulation fixing FID Green

Recommended loads¹⁾ for a single anchor.

The given loads are valid for chipboard screws with maximum diameter.

Type		FID Green 50	FID Green 90
Screw diameter	[mm]	4.5 - 5,0	6.0
Recommended loads in the respective base material N _{rec} ²⁾			
Polystyrene	PS 15	[kN] 0.07	0.17
Polystyrene	PS 20	[kN] 0.10	0.20

¹⁾ Required safety factors are considered.

²⁾ Valid for tensile loads.

Injection mortar FIS Green

The first approved injection mortar made with renewable raw materials

2



Building renovation

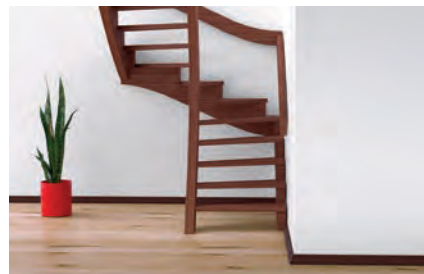

Bonding in interior construction

Applications

Injection mortar for use with:

- Threaded rods FIS A, see page 129
- Internal threaded anchor RG MI, see page 141
- Rebar anchor FRA, see page 169
- Concrete steel bars, see page 176
- Injection anchor sleeves FIS H, see page 148
- NSF certificate verifies its suitability for applications in drinking water

Advantages

- The worldwide first injection mortar with renewable raw materials. The share of renewable raw materials is certified by DIN CERTCO / TÜV Rheinland.
- Because of the European Technical Assessment it is possible to use the injection system in the area of public buildings.
- The low content of volatile organic compounds (VOC) has a positive effect for the evaluation of fixings in “Green Build-

- ing”-projects.
- Biobased raw materials increase the residential and workplace quality and preserve valuable resources for future generations.
- The injection system is not mandatory for indication and thus reduces risks for installers and the environment.
- FIS Green is suitable for the use with the complete fischer injection accessories.

Certificates



ETA-14/0408, for non-cracked concrete

ETA-14/0471, for masonry



Fire resistance classification R120



Certified to NSF/ANSI 61

Building materials

Approved for anchorings in:

- Concrete C20/25 to C50/60, non-cracked
- Solid brick
- Vertically perforated brick
- Solid sand-lime brick
- Perforated sand-lime brick
- Aerated concrete

Functioning

- FIS Green is a 2-component injection mortar.
- Resin and hardener are stored in two separate chambers and are not mixed and activated until extrusion through the static mixer.
- The injection cartridges are quick and easy to use with the fischer dispensers.
- Partially used cartridges can be reused by changing the static mixer.
- Related accessories for the various applications can be found on pages “non-cracked concrete” and “masonry”.

Installation in concrete with FIS Green and FIS A / RG M

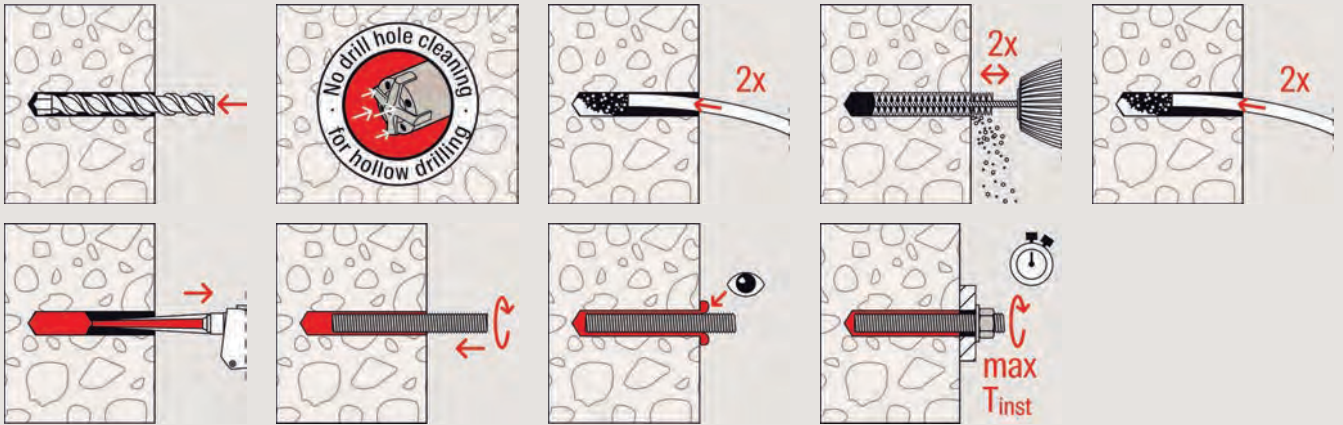

Installation in concrete with FIS Green and RG M I

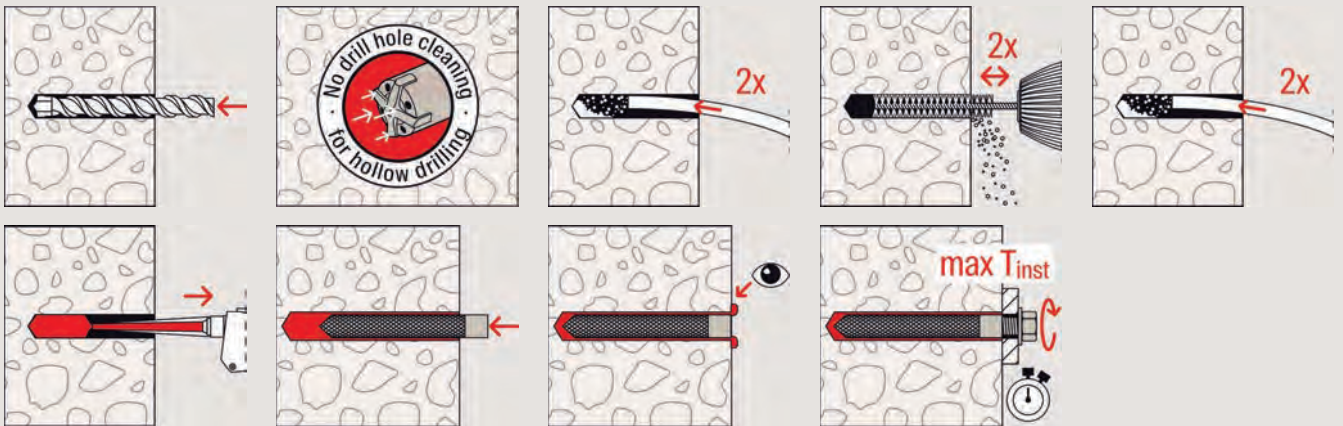

Installation in solid brick with FIS Green and FIS A / RG M

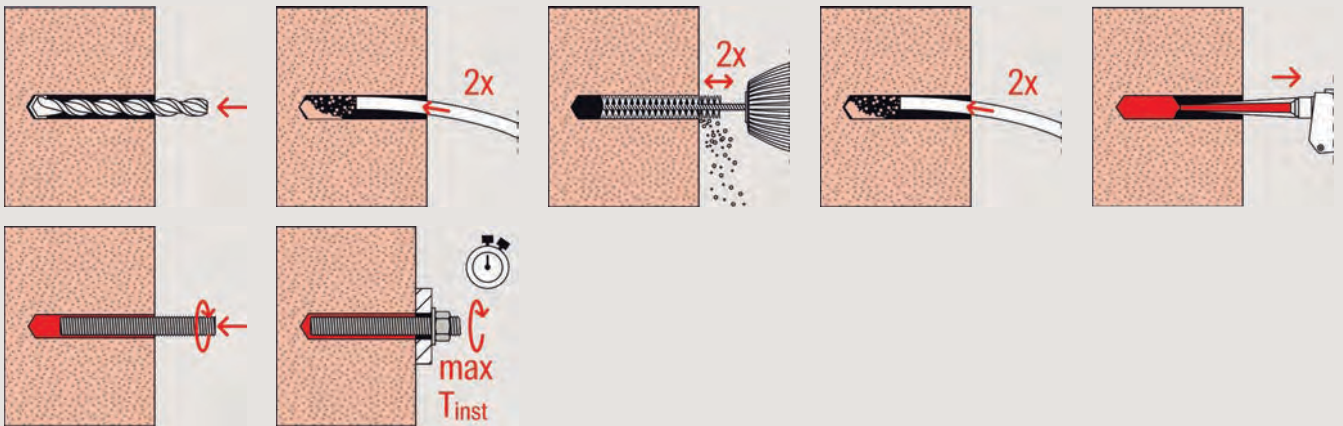

Installation in hollow blocks with FIS Green and FIS HK + FIS A / RG M

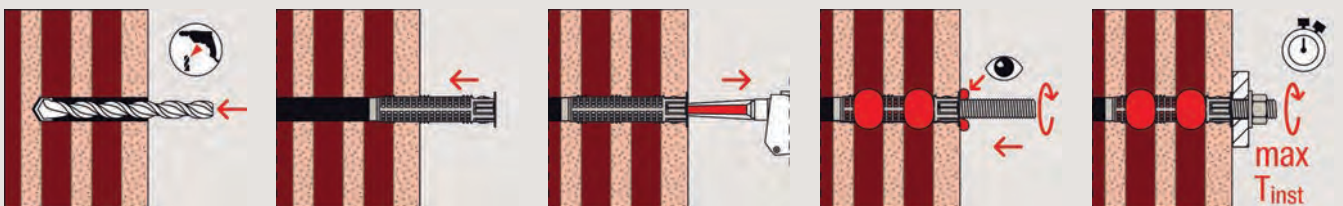

Installation in aerated concrete with FIS Green and FIS A / RG M

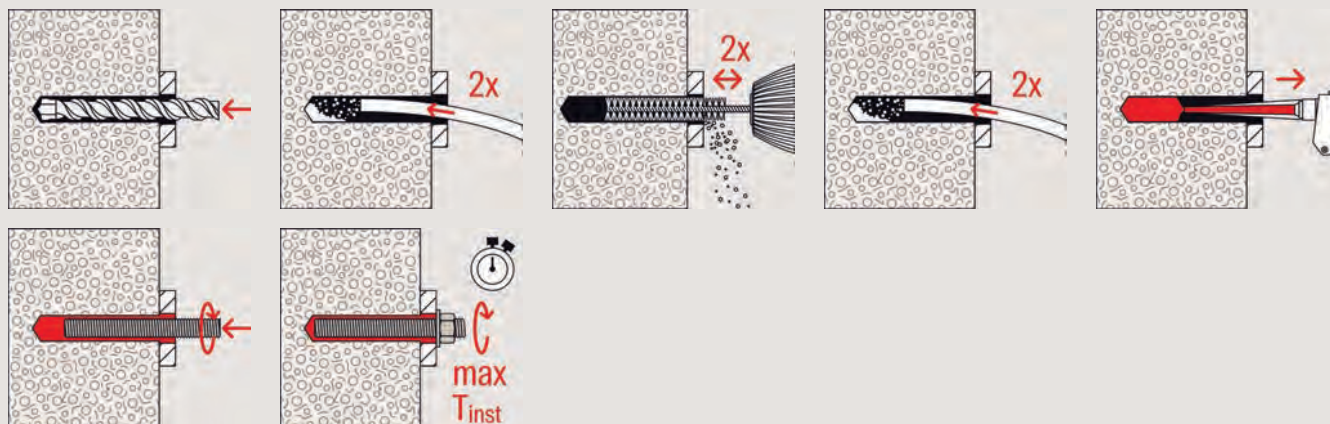

2

Technical data

Injection mortar FIS Green



FIS Green 300 T

FIS MR Plus

Item	Item No.	Approval ETA	Languages on the cartridge	Scale unit	Contents	Sales unit [pcs]
FIS Green 300 T	522223	●	DE	150	1 cartridge 300 ml, 2 x FIS MR Plus	12
FIS Green 300 T K	523244	●	DE	150	1 cartridge 300 ml, 2 x FIS MR Plus (incl. clip with europerforation)	4
FIS Green 300 T	522989	●	FR	150	1 cartridge 300 ml, 2 x FIS MR Plus with transparent Clip	4
FIS Green 300 T	523245	●	IT	150	1 cartridge 300 ml, 2 x FIS MR Plus with transparent Clip	12
FIS Green 300 T	538219	●	CS, SK	150	1 cartridge 300 ml, 2 x FIS MR Plus	12
FIS Green 300 T	532972	●	DA, SV, NO, FI	150	1 cartridge 300 ml, 2 x FIS MR Plus with transparent Clip	12
FIS MR Plus	545853	—	—	—	10 static mixer FIS MR Plus	10

Curing times

FIS Green Cartridge temperature (mortar) [°C]	Maximum processing time t_{work} [min.]	Temperature at anchoring base		Minimum curing time ¹⁾	
		[°C]		t_{cure} [hrs.]	[min.]
+5	13	±0 – +5		6	–
+10	9	> +5 – +10		4	–
+20	5	> +10 – +20		–	90
+30	4	> +20 – +30		–	60
+40	2	> +30 – +40		–	30

1) In damp concrete and water-filled holes, the curing time is to be doubled.

Loads

Injection system FIS Green with threaded rod FIS A resp. RG M

Permissible loads of a single anchor^{1) 2)} in normal concrete of strength class C20/25.
For the design the complete current assessment ETA-14/0408 has to be considered.

Type	Material / surface ³⁾	Effective anchorage depth h_{ef} [mm]	Minimum member thickness h_{min} [mm]	Maximum Installation torque $T_{inst, max}$ [Nm]	Non-cracked concrete			
					Permissible tension (N_{perm}) and shear loads (V_{perm}); minimum spacing (s_{min}) and edge distances (c_{min}) with reduced loads			
					$N_{perm}^{4)}$ [kN]	$V_{perm}^{4)}$ [kN]	$s_{min}^{4)}$ [mm]	$c_{min}^{4)}$ [mm]
FIS A M 8	5.8	60	100	10	5.7	6.3	40	40
	5.8	80	110	10	7.6	6.3	40	40
	5.8	160	190	10	9.0	6.3	40	40
	R-70	60	100	10	5.7	6.0	40	40
	R-70	80	110	10	7.6	6.0	40	40
	R-70	160	190	10	9.9	6.0	40	40
FIS A M 10	5.8	60	100	20	6.7	9.7	45	45
	5.8	90	120	20	10.1	9.7	45	45
	5.8	200	230	20	13.8	9.7	45	45
	R-70	60	100	20	6.7	9.2	45	45
	R-70	90	120	20	10.1	9.2	45	45
	R-70	200	230	20	15.7	9.2	45	45
FIS A M 12	5.8	70	100	40	8.9	14.3	55	55
	5.8	110	140	40	14.0	14.3	55	55
	5.8	240	270	40	20.5	14.3	55	55
	R-70	70	100	40	8.9	13.7	55	55
	R-70	110	140	40	14.0	13.7	55	55
	R-70	240	270	40	22.5	13.7	55	55
FIS A M 16	5.8	80	120	60	12.0	26.9	65	65
	5.8	125	170	60	18.7	26.9	65	65
	5.8	320	360	60	37.6	26.9	65	65
	R-70	80	120	60	12.0	25.2	65	65
	R-70	125	170	60	18.7	25.2	65	65
	R-70	320	360	60	42.0	25.2	65	65
FIS A M 20	5.8	90	140	120	14.6	35.0	85	85
	5.8	170	220	120	27.6	42.3	85	85
	5.8	400	450	120	58.6	42.3	85	85
	R-70	90	140	120	14.6	35.0	85	85
	R-70	170	220	120	27.6	39.4	85	85
	R-70	400	450	120	64.8	39.4	85	85

¹⁾ Design according to EN 1992-4:2018 (for static resp. quasi-static loads). The partial safety factors for material resistance as regulated in the ETA as well as a partial safety factor for load actions of $\gamma_L = 1.4$ are considered. As a single anchor counts e.g. an anchor with a spacing $s \geq 3 \times h_{ef}$ and an edge distance $c \geq 1.5 \times h_{ef}$. Accurate data see ETA.

²⁾ The specified loads are valid for anchorages in dry and damp concrete. For temperatures in the anchoring substrate up to 50 °C (resp. short term up to 80 °C). Drill hole cleaning as per specification in the ETA. The factor Ψ_{sus} for sustained load was taken into account with 1.0.

³⁾ Further steel grades, versions and technical data see ETA, e.g. for dry internal conditions, galvanised steel (gvz); for damp interiors and for outdoor use, stainless steel (R).

⁴⁾ In the case of combinations of tension and shear loads, bending moments with reduced or minimum spacing and edge distances (anchor groups), the design must be carried out in accordance with the provisions of the complete ETA and the provisions of the EN 1992-4:2018. We recommend using our anchor design software C-FIX.

Loads

Injection system FIS Green with internal threaded anchor RG M I

Permissible loads of a single anchor^{1) 2)} in normal concrete of strength class C20/25.
For the design the complete current assessment ETA-14/0408 has to be considered.

Type	Screw Material ³⁾	Effective anchorage depth h_{ef} [mm]	Minimum member thickness h_{min} [mm]	Maximum Installation torque $T_{inst, max}$ [Nm]	Non-cracked concrete			
					Permissible tension (N_{perm}) and shear loads (V_{perm}); minimum spacing (s_{min}) and edge distances (c_{min}) with reduced loads			
					$N_{perm}^{4)}$ [kN]	$V_{perm}^{4)}$ [kN]	$s_{min}^{4)}$ [mm]	$c_{min}^{4)}$ [mm]
RG M 8 I	5.8	90	120	10	9.0	5.3	55	55
	8.8	90	120	10	11.9	8.3	55	55
	R-70	90	120	10	9.9	5.9	55	55
RG M 10 I	5.8	90	130	20	13.8	8.3	65	65
	8.8	90	130	20	13.9	13.3	65	65
	R-70	90	130	20	13.9	9.3	65	65
RG M 12 I	5.8	125	170	40	20.2	12.1	75	75
	8.8	125	170	40	20.2	19.3	75	75
	R-70	125	170	40	20.2	13.5	75	75
RG M 16 I	5.8	160	210	80	27.8	22.4	95	95
	8.8	160	210	80	27.8	30.9	95	95
	R-70	160	210	80	27.8	25.1	95	95

¹⁾ Design according to EN 1992-4:2018 (for static resp. quasi-static loads). The partial safety factors for material resistance as regulated in the ETA as well as a partial safety factor for load actions of $\gamma_L = 1.4$ are considered. As a single anchor counts e.g. an anchor with a spacing $s \geq 3 \times h_{ef}$ and an edge distance $c \geq 1.5 \times h_{ef}$. Accurate data see ETA.

²⁾ The specified loads are valid for anchorages in dry and damp concrete. For temperatures in the anchoring substrate up to 50 °C (resp. short term up to 80 °C). Drill hole cleaning as per specification in the ETA. The factor Ψ_{sus} for sustained load was taken into account with 1.0.

³⁾ Further steel grades, versions and technical data see ETA, e.g. for dry internal conditions, galvanised steel (gvz); for damp interiors and for outdoor use, stainless steel (R).

⁴⁾ In the case of combinations of tension and shear loads, bending moments with reduced or minimum spacing and edge distances (anchor groups), the design must be carried out in accordance with the provisions of the complete ETA and the provisions of the EN 1992-4:2018. We recommend using our anchor design software C-FIX.

Loads

Injection system FIS Green with threaded rod FIS A in solid and perforated masonry

Permissible loads^{1) 2)} for a single anchor in masonry for pre-positioned installation.
For the design the complete current assessment ETA-14/0471 has to be considered.

Type	Compressive brick strength f_b [N/mm ²]	Brick raw density ρ [kg/dm ³]	Minimum brick dimensions ³⁾ (L x W x H) [mm]	Effective anchorage depth h_{ef} [mm]	Minimum member thickness h_{min} [mm]	Maximum installation torque $T_{inst,max}$ [Nm]	Permissible tensile load ⁴⁾ N_{perm} [kN]	Permissible shear load ⁴⁾ V_{perm} [kN]	Minimum-spacing ⁵⁾ $S_{min \parallel} / S_{min \perp}$ [mm]	Characteristic resp. minimum edge distance ⁵⁾ $c_{cr} = c_{min}$ [mm]
Solid brick Mz, NF, acc. to EN 771-1										
M6	≥ 10	≥ 1.8	240 x 115 x 71	≥ 50	115	4	0.43	0.71	150 / 150	100
M8	≥ 10	≥ 1.8	240 x 115 x 71	≥ 50	115	10	0.71	0.71	150 / 150	100
M10	≥ 10	≥ 1.8	240 x 115 x 71	80	115	10	1.29	1.14	240 / 240	100
M10	≥ 10	≥ 1.8	240 x 115 x 71	200	240	10	3.14	2.43	300 / 300	100
M12	≥ 10	≥ 1.8	240 x 115 x 71	80	115	10	1.43	1.14	240 / 240	100
M12	≥ 10	≥ 1.8	240 x 115 x 71	200	240	10	2.00	3.29	300 / 300	100
Solid sand-lime brick KS, acc. to EN 771-2										
M6	≥ 10	≥ 1.8	240 x 115 x 71	50	115	4	0.43	0.86	150 / 150	100
M8	≥ 10	≥ 1.8	240 x 115 x 71	50	115	10	0.71	1.14	150 / 150	100
M10	≥ 10	≥ 1.8	240 x 115 x 71	80	115	10	0.86	1.14	240 / 240	100
M10	≥ 10	≥ 1.8	240 x 115 x 71	200	240	10	2.57	1.14	300 / 300	100
M12	≥ 10	≥ 1.8	240 x 115 x 71	80	115	10	0.86	1.43	240 / 240	100
M12	≥ 10	≥ 1.8	240 x 115 x 71	200	240	10	2.57	1.43	300 / 300	100
Perforated sand-lime brick KSL, acc. to EN 771-2³⁾										
M6 / M8 with FIS H 12 x 85 K	≥ 12	≥ 1.4	240 x 175 x 113	85	175	2	0.34	0.71	240 / 115	100
M8 / M10 with FIS H 16 x 85 K	≥ 12	≥ 1.4	240 x 175 x 113	85	175	4	0.57	1.57	240 / 115	100
M12 / M16 with FIS H 20 x 85 K	≥ 12	≥ 1.4	240 x 175 x 113	85	175	4	0.57	1.29	240 / 115	100
M8 / M10 with FIS H 16 x 130 K	≥ 12	≥ 1.4	240 x 175 x 113	130	175	4	0.57	1.57	240 / 115	100
M12 / M16 with FIS H 20 x 130 K	≥ 12	≥ 1.4	240 x 175 x 113	130	175	4	0.43	1.29	240 / 115	100
Vertically perforated brick Hlz, acc. to EN 771-1³⁾										
M6 / M8 with FIS H 12 x 85 K	≥ 10	≥ 1.0	240 x 175 x 113	85	175	2	0.57	1.14	240 / 115	120
M8 / M10 with FIS H 16 x 85 K	≥ 10	≥ 1.0	240 x 175 x 113	85	175	4	0.57	1.57	240 / 115	120
M12 / M16 with FIS H 20 x 85 K	≥ 10	≥ 1.0	240 x 175 x 113	85	175	5	0.71	1.71	240 / 115	120
M8 / M10 with FIS H 16 x 130 K	≥ 10	≥ 1.0	240 x 175 x 113	130	175	4	0.71	1.57	240 / 115	120
M12 / M16 with FIS H 20 x 130 K	≥ 10	≥ 1.0	240 x 175 x 113	130	175	4	0.57	1.71	240 / 115	120
Aerated concrete acc. to EN 771-4³⁾										
M6	≥ 2	≥ 0.35	-	≥ 100	130	1	0.54	0.32	240 / 115	80
M6	≥ 4	≥ 0.50	-	≥ 100	130	1	0.71	0.54	240 / 115	80
M8	≥ 2	≥ 0.35	-	≥ 100	130	2	0.71	0.32	240 / 115	80
M8	≥ 4	≥ 0.50	-	≥ 100	130	2	0.89	0.54	240 / 115	80
M10	≥ 2	≥ 0.35	-	≥ 100	130	4	0.71	0.32	240 / 115	80
M10	≥ 4	≥ 0.50	-	≥ 100	130	4	1.07	0.54	240 / 115	80
M12	≥ 2	≥ 0.35	-	≥ 100	130	4	0.89	0.32	240 / 115	80
M12	≥ 4	≥ 0.50	-	≥ 100	130	4	1.07	0.54	240 / 115	80
M16	≥ 2	≥ 0.35	-	≥ 100	130	4	0.89	0.43	240 / 115	80
M16	≥ 4	≥ 0.50	-	≥ 100	130	4	1.07	0.54	240 / 115	80

¹⁾ The required partial safety factors for material resistance as well as a partial safety factor for load actions of $\gamma_L = 1.4$ are considered. Load values are valid for zinc-plated steel, stainless steel R and highly corrosion-resistant steel HCR. In perforated bricks and hollow blocks threaded rod FIS A in combination with anchor sleeve FIS H K.

²⁾ The given loads are valid for installation and use of fixations in dry masonry - use category d/d - for temperatures in the substrate up to 50 °C (resp. short term up to 80 °C) and drill hole cleaning according to assessment. The given brick types in combination with the permissible loads are an extract of the assessment.

³⁾ More information about, e.g. hole patterns, assortment of anchor sleeves FIS H K see assessment.

⁴⁾ In the case of combinations of tensile and shear loads, bending moments and reduced edge and axial spacings (anchor groups), the design must be carried out in accordance with the provisions of the complete assessment.

⁵⁾ Minimum feasible spacing resp. edge distance. Details as well as to the distances to joints see assessment.













⁶⁾ Cylindrical drill hole.









3

Chemical fixings







MORTARS AND CAPSULES FOR GENERAL APPLICATIONS











Highbond-System FHB II	54	
Highbond-System FHB II Inject	62	
Superbond-System FSB	67	
Resin anchor RM II	75	
Epoxy mortar FIS EM Plus	79	
Epoxy mortar FIS EB	84	
Epoxy mortar FIS EP	87	
Injection mortar FIS V Plus	90	
Injection mortar FIS V	99	
Injection mortar FIS VL	107	
Injection mortar FIS Green	113	
Injection mortar FIS P Plus	119	
Injection mortar FIS P	123	









ANCHOR RODS



















Threaded rod FIS A	128	
Threaded rod RG M	137	
Internal-threaded anchor RG M I	142	
Internal threaded sockets FIS E	144	
Accessories for push-through installation	147	
Injection anchor sleeves	149	





SPECIAL APPLICATIONS

Highbond anchor dynamic FHB dyn	153	
Superbond dynamic FSB dyn	158	
Dynamic-Anchor FDA	167	
Rebar connections	170	
Concrete-Concrete Shear Connector FCC	177	
Remedial wall tie VBS 8	179	
Weather facing reconstruction system FWS II	181	
Can System FCS	184	
fill & fix injection fixing	186	
Dispenser	189	
Accessories	194	

Mortar cartridges		Approved substrates (ETA)					Approved features										Page
Positioning		Cracked concrete	Non-cracked concrete	Solid masonry	Perforated masonry	Aerated concrete	Post-installed rebar connection	ICC	Fire resistance RT20	Seismic approval	Waterfilled drill hole	Diamond drilling	Hollow drilling	Dynamic loads	Others		
	Highbond-System FHB II The best performance in cracked concrete	•	•	-	-	-	-	-	•	-	-	-	•	•	ZTV 1200 °C, BZS shock tested	54	
	Superbond-System FSB The concrete all-rounder	•	•	-	-	-	•	•	•	C1, C2	-	-	•	•	Underwater applications	67	
	Epoxy mortar FIS EM Plus The powerful injection mortar for rebar connections and cracked concrete	•	•	-	-	-	•	•	•	C1, C2	•	•	•	-	-	79	
	Epoxy mortar FIS EB The basic epoxy mortar for applications in concrete	•	•	-	-	-	•	•	•	C1, C2	•	•	•	-	-	84	
	Epoxy mortar FIS EP The cost-efficient epoxy mortar for applications in concrete	(•)	(•)	-	-	-	-	-	-	-	-	-	-	-	-	87	
	Injection mortar FIS V Plus The powerful universal mortar for concrete and masonry	•	•	•	•	•	•	•	•	C1, C2	•	-	•	-	-	90	
	Injection mortar FIS V The versatile injection mortar for anchorings in masonry and cracked concrete	•	•	•	•	•	•	•	•	C1, C2	•	-	•	-	-	99	
	Injection mortar FIS VL The solid injection mortar for standard applications in cracked concrete and masonry	•	•	•	•	•	•	-	•	-	•	-	•	-	-	107	
	Injection mortar FIS Green The first approved mortar made with renewable raw materials	-	•	•	•	•	-	-	•	-	-	-	-	-	Bio-based, EPD, Émission Dans L'Air Intérieur, NSF	113	
	Injection mortar FIS P Plus The approved injection mortar for anchorings in masonry and non-cracked concrete	-	•	•	•	•	-	-	•	-	•	-	•	-	-	119	
	Injection mortar FIS P The reliable injection mortar for anchorings in masonry	-	-	(•)	(•)	(•)	-	-	-	-	-	-	-	-	-	123	

Mortar cartridges		Approved substrates (ETA)					Approved features									Page
							Post- installed rebar connection	ICC	Fire resistance RT20	Seismic approval	Waterfilled drill hole	Diamond drilling	Hollow drilling	Dynamic loads	Others	
Positioning		Cracked concrete	Non-cracked concrete	Solid masonry	Perforated masonry	Aerated concrete										
 Resin capsules FHB II-P, FHB II-PF high speed	The best performance in cracked concrete	•	•	-	-	-	-	-	•	-	•	-	•	-	-	54
 Resin capsules RSB	The concrete all-rounder	•	•	-	-	-	-	•	•	C1	•	•	•	•	-	67
 Resin capsules RM II	Bonded anchor for cracked concrete without drill hole cleaning	•	•	-	-	-	-	-	•	-	•	-	•	-	-	75

Mortar cartridges												
												
	FIS HB	FIS SB	FIS EM Plus	FIS EB	FIS EP	FIS V Plus	FIS V	FIS VL	FIS Green	FIS P Plus	FIS P	
Positioning	Best performance in concrete	Concrete all-rounder	Powerful rebar connections + cracked concrete	Basic epoxy mortar for concrete	The cost-efficient epoxy mortar for applications in concrete	The powerful universal mortar for concrete and masonry	Versatile mortar for masonry and cracked concrete	Solid mortar for standard anchorings in masonry and cracked concrete	First approved mortar made with renewable raw materials	Approved for masonry and non-cracked concrete	Reliable in masonry	
	-	•	•	•	(•)	•	•	•	•	•	(•)	Page 128
Threaded rod FIS A												
	-	•	•	•	(•)	•	•	•	•	•	(•)	137
Threaded rod RG M												
	-	•	•	-	-	•	•	•	•	-	-	142
Internal threaded anchor RG M I												
	-	-	-	-	-	•	•	•	•	•	(•)	144
Internal threaded socket FIS E												
	•	-	-	-	-	-	-	-	-	-	-	54
Highbond anchor FHB II-A L / FHB II-AS												
	•	-	-	-	-	-	-	-	-	-	-	54
Highbond anchor FHB II-A L Inject / FHB II-A S Inject												
	•	-	-	-	-	-	-	-	-	-	-	153
FHB dyn												
	•	-	-	-	-	-	-	-	-	-	-	167
FDA												

Mortar capsules				
				
	FHB II-P, FHB II-PF high speed	RSB	RM II	
Positioning	Best performance in concrete	Concrete all-rounder	Bonded anchor for cracked concrete without drill hole cleaning	Page
 Threaded rod FIS A	-	-	-	128
 Threaded rod RG M	-	•	•	137
 Internal threaded anchor RG M I	-	•	•	142
 Internal threaded socket FIS E	-	-	-	144
 Highbond anchor FHB II-A L/FHB II-AS	•	-	-	54
 Highbond anchor FHB II-A L inject/FHB II-A S inject	-	-	-	54
 FHB dyn	-	-	-	153
 FDA	-	-	-	167

Highbond system FHB II

The best performance in cracked concrete

3



Banisters



Steel girders

Applications

- Guard rails
- Façades
- Staircases
- Steel brackets
- Machines
- Silo installations
- Masts
- Rash protection
- Steelwork constructions
- Timber constructions

Advantages

- The Highbond system FHB II achieves the highest load values in cracked concrete. Thus fewer fixing points and smaller anchor plates are required.
- The injection mortar FIS HB and the capsules FHB II-P/PF offer the same performance and can be used with the FHB II-A S (short version) or L (long version) anchor rods. Thus, you can select the most economical solution based on requirements.
- The large cartridge size of the injection

- mortar FIS HB is ideally suited for serial installation.
- The pre-portioned resin capsule FHB II-P / PF HIGH SPEED is the economical solution for single applications or under water. A cleaning of the borehole during processing with capsule is not required.
- The special formulation used in the capsule FHB II-PF HIGH SPEED ensures especially fast curing and allows installation without waiting times.

Certificates



ETA-05/0164, for cracked concrete



shock-tested; BZS approval for shockproof fixings in civilian shelters.



Fire resistance classification R120



ZTV

Building materials

- Approved for:
- Concrete C20/25 to C50/60, cracked and non-cracked
- Also suitable for:
- Concrete C12/15

Versions

- Zinc-plated steel
- Stainless steel
- Highly corrosion-resistant steel

Functioning

- The FHB II is a bonded anchor with torque-controlled expansion for pre-positioned and push-through installation.
- The anchor rod can be set either with injection mortar FIS HB or with the capsule FHB II-P / FHB II-PF HIGH SPEED, and is fully bonded in the drill hole.
- When tightening the hexagon nut, the anchor rod cones are pulled into the mortar shell, which expands against the drill hole wall.
- The styrene-free vinyl ester mortar fully seals the drill hole.
- When using the resin capsule, set the anchor rod through rotating and hitting motions with a hammer drill. The RA-SDS setting tool, item no. 62420 is used.

For use with

Dispenser page 189



Accessories page

194



Installation in concrete with capsule FHB II-P

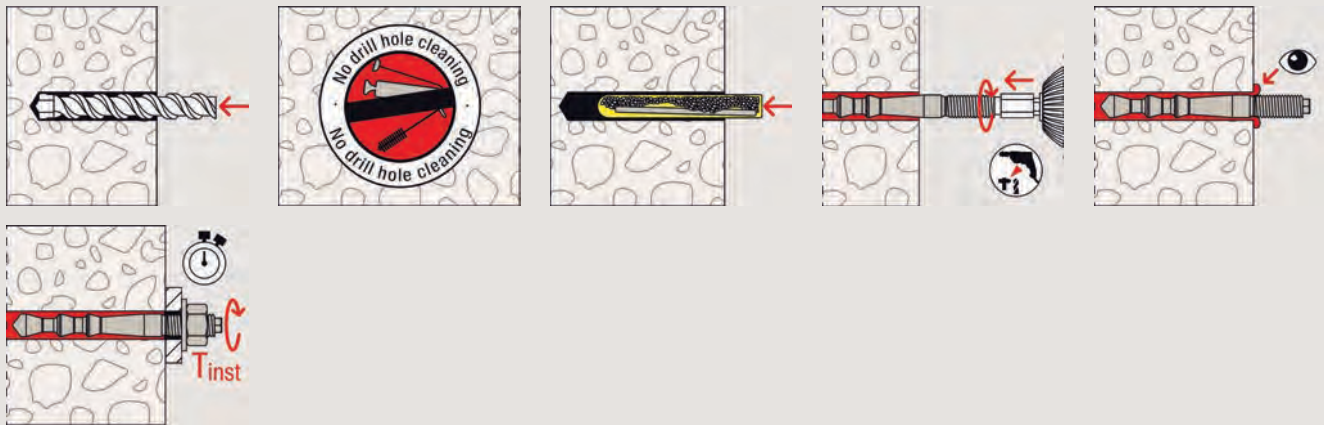

3

Pre-positioned installation in concrete with FIS HB

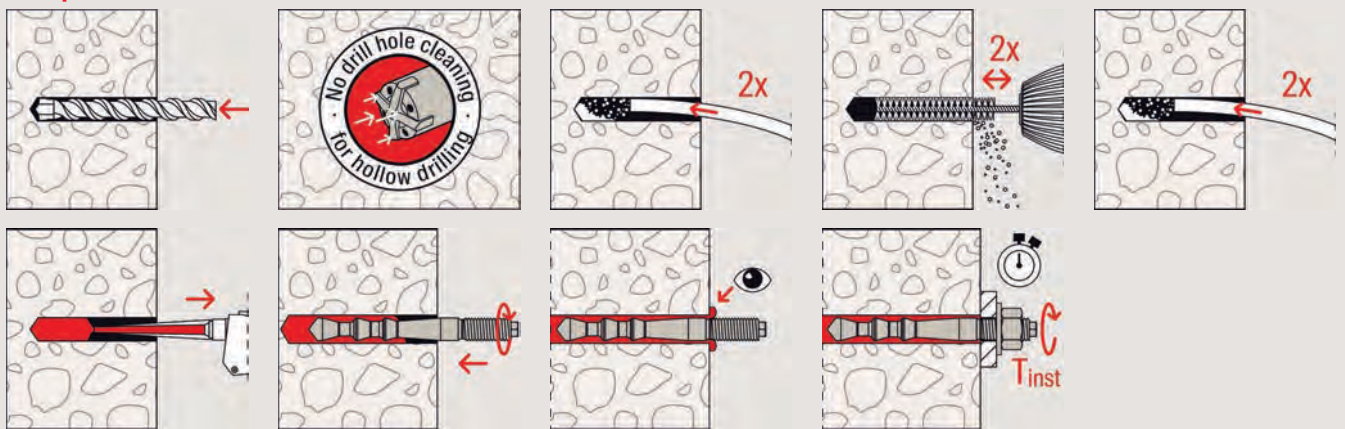

Technical data

Injection mortar FIS HB



FIS HB 360 S + FIS MR Plus

FIS HB 150 C

Item	Item No.	Approval ETA	Languages on the cartridge	Scale unit	Contents	Sales unit [pcs]
FIS HB 360 S	519125	●	DE	180	1 cartridge 360 ml, 2 x FIS MR Plus	6
FIS HB 360 S	562659	●	DE, FR, IT, NL	180	1 cartridge 360 ml, 2 x FIS MR Plus	6
FIS HB 360 S	562658	●	EN, ZH	180	1 cartridge 360 ml, 2 x FIS MR Plus	6
FIS HB 360 S	562660	●	EN, PL, RU, CS, SK	180	1 cartridge 360 ml, 2 x FIS MR Plus	6
FIS HB 360 S	562661	●	EN, ES, PT, EL	180	1 cartridge 360 ml, 2 x FIS MR Plus	6
FIS HB 150 C	519665	●	DE, FR, NL	70	1 cartridge 145 ml, 2 x FIS MR Plus	6
FIS MR Plus	545853	—	—	—	10 static mixer FIS MR Plus	10

Curing times

FIS HB System temperature FIS HB (Mortar min. +5 °C) [°C]	Maximum processing time FIS HB t_{work} [min.]	Minimum curing time FIS HB ¹⁾ t_{cure} [min.]
-5 - -1	–	360
0 - +4	–	180
> +5 - +9	15	90
> +10 - +19	6	35
> +20 - +29	4	20
> +30 - +40	2	12

1) In wet concrete the curing times must be doubled.

Technical data

Resin capsule FHB II-P



FHB II-P (standard)

Item	Item No.	Approval ETA	Drill hole diameter d_0 [mm]	Drill hole depth h_0 [mm]	Anchorage depth h_{ef} [mm]	Match	Sales unit [pcs]
FHB II-P 8 x 60	096824	●	10	75	60	FHB II-A L M 8 x 60	10
FHB II-P 10 x 60	096847	●	10	75	60	FHB II-A S M 10 x 60	10
FHB II-P 10 x 75	508016	●	10	90	75	FHB II-A S M 10 x 75	10
FHB II-P 10 x 95	096843	●	12	110	95	FHB II-A L M 10 x 95	10
FHB II-P 12 x 75	096848	●	12	90	75	FHB II-A S M 12 x 75	10
FHB II-P 12 x 100	507922	●	14	115	100	FHB II-A L M 12 x 100	10
FHB II-P 12 x 120	096844	●	14	135	120	FHB II-A L M 12 x 120	10
FHB II-P 16 x 95	096849	●	16	110	95	FHB II-A S M 16 x 95	10
FHB II-P 16 x 125	507923	●	18	140	125	FHB II-A L M 16 x 125	10
FHB II-P 16 x 145	507924	●	18	160	145	FHB II-A L M 16 x 145	10
FHB II-P 16 x 160	096845	●	18	175	160	FHB II-A L M 16 x 160	10
FHB II-P 20 x 170	507925	●	25	190	170	FHB II-A S M 20 x 170	4
FHB II-P 20 x 210	096846	●	25	235	210	FHB II-A L M 20 x 210	4
FHB II-P 24 x 170	096851	●	25	190	170	FHB II-A S M 24 x 170	4
FHB II-P 24 x 210	507926	●	25	235	210	FHB II-A L M 24 x 210	4

Technical data

Resin capsule FHB II-PF HIGH SPEED



FHB II-PF HIGH SPEED (quick version)

Item	Item No.	Approval ETA	Drill hole diameter d_0 [mm]	Drill hole depth h_0 [mm]	Anchorage depth h_{ef} [mm]	Match	Sales unit [pcs]
FHB II-PF 8 x 60	500542	●	10	75	60	FHB II-A L M 8 x 60	10
FHB II-PF 10 x 60	500547	●	10	75	60	FHB II-A S M 10 x 60	10
FHB II-PF 10 x 75	507999	●	10	90	75	FHB II-A S M 10 x 75	10
FHB II-PF 10 x 95	500543	●	12	110	95	FHB II-A L M 10 x 95	10
FHB II-PF 12 x 75	500548	●	12	90	75	FHB II-A S M 12 x 75	10
FHB II-PF 12 x 100	508000	●	14	115	100	FHB II-A L M 12 x 100	10
FHB II-PF 12 x 120	500544	●	14	135	120	FHB II-A L M 12 x 120	10
FHB II-PF 16 x 95	500549	●	16	110	95	FHB II-A S M 16 x 95	10
FHB II-PF 16 x 125	508001	●	18	140	125	FHB II-A L M 16 x 125	10
FHB II-PF 16 x 145	508002	●	18	160	145	FHB II-A L M 16 x 145	10
FHB II-PF 16 x 160	500545	●	18	175	160	FHB II-A L M 16 x 160	10

Technical data

Resin capsule FHB II-PF HIGH SPEED



FHB II-PF HIGH SPEED (quick version)

Item	Item No.	Approval ETA	Drill hole diameter d_0 [mm]	Drill hole depth h_0 [mm]	Anchorage depth h_{ef} [mm]	Match	Sales unit [pcs]
FHB II-PF 20 x 170	508003	●	25	190	170	FHB II-A S M 20 x 170	4
FHB II-PF 20 x 210	500546	●	25	235	210	FHB II-A L M 20 x 210	4
FHB II-PF 24 x 170	500550	●	25	190	170	FHB II-A S M 24 x 170	4
FHB II-PF 24 x 210	508004	●	25	235	210	FHB II-A L M 24 x 210	4

Curing times

FHB II P/FHB II-PF HIGH SPEED System temperature [°C]	Minimum curing time FHB II-P t_{cure} [min.]	Minimum curing time FHB II-PF HIGH SPEED t_{cure} [min.]
-5 - ±0	240	8
> +1 - +10	45	6
> +11 - +20	20	4
> +20	10	2

In wet concrete or flooded holes the curing times must be doubled.

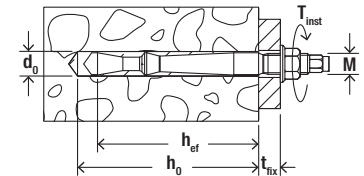

Technical data

Highbond anchor FHB II-A S



FHB II-A S (short version)

Item	Zinc-plated steel	Stainless steel	Highly corrosion resistant steel	Approval ETA	Drill hole diameter	Drill hole depth	Anchorage depth	Usable length	Thread M	Width across nut	Sales unit [pcs]
	Item No. gvz	Item No. R	Item No. HCR		d_0 [mm]	h_0 [mm]	h_{ef} [mm]	t_{fix} [mm]		SW [mm]	
FHB II-A S M10 x 60/10	097072	097630	097704 ¹⁾	●	10	75	60	10	M 10	17	10
FHB II-A S M10 x 60/20	097073	097631	—	●	10	75	60	20	M 10	17	10
FHB II-A S M10 x 60/30	—	050571	—	●	10	75	60	30	M 10	17	10
FHB II-A S M10 x 60/40	—	097632	—	●	10	75	60	40	M 10	17	10
FHB II-A S M10 x 60/60	097074	097633	—	●	10	75	60	60	M 10	17	10
FHB II-A S M10 x 60/100	097206	097634	—	●	10	75	60	100	M 10	17	10
FHB II-A S M10 x 75/10	506884	506888	—	●	10	90	75	10	M 10	17	10
FHB II-A S M10 x 75/20	506885	506889	—	●	10	90	75	20	M 10	17	10
FHB II-A S M10 x 75/40	—	506890	—	●	10	90	75	40	M 10	17	10
FHB II-A S M10 x 75/60	506886	506891	—	●	10	90	75	60	M 10	17	10
FHB II-A S M10 x 75/100	506887	506892	—	●	10	90	75	100	M 10	17	10
FHB II-A S M12 x 75/10	097257	097635	—	●	12	90	75	10	M 12	19	10
FHB II-A S M12 x 75/25	097268	097636	097706 ¹⁾	●	12	90	75	25	M 12	19	10
FHB II-A S M12 x 75/40	—	097637	—	●	12	90	75	40	M 12	19	10
FHB II-A S M12 x 75/60	097274	097638	—	●	12	90	75	60	M 12	19	10

1) Delivery time on request.

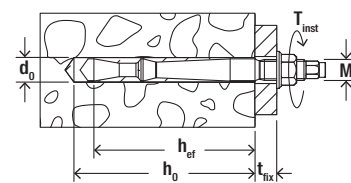

Technical data

Highbond anchor FHB II-A S



FHB II-A S (short version)

3

Item	Zinc-plated steel	Stainless steel	Highly corrosion resistant steel	Approval	Drill hole diameter	Drill hole depth	Anchorage depth	Usable length	Thread	Width across nut	Sales unit
	Item No. gvz	Item No. R	Item No. HCR	ETA	d_0 [mm]	h_0 [mm]	h_{ef} [mm]	t_{fix} [mm]	M	SW [mm]	[pcs]
FHB II-A S M12 x 75/100	097275	097639	—	●	12	90	75	100	M 12	19	10
FHB II-A S M12 x 75/165	097280	097640	—	●	12	90	75	165	M 12	19	10
FHB II-A S M16 x 95/30	097281	097641	097708 ¹⁾	●	16	110	95	30	M 16	24	10
FHB II-A S M16 x 95/60	097286	097642	—	●	16	110	95	60	M 16	24	10
FHB II-A S M16 x 95/100	097295	097643	—	●	16	110	95	100	M 16	24	10
FHB II-A S M16 x 95/165	097296	097644	—	●	16	110	95	165	M 16	24	10
FHB II-A S M20 x 170/50	506917	506919	—	●	25	190	170	50	M 20	30	4
FHB II-A S M24 x 170/50	097297	097645	—	●	25	190	170	50	M 24	36	4
FHB II-A S M24 x 170/70	552057	—	—	●	25	190	170	70	M 24	36	4

1) Delivery time on request.

Filling quantities

FHB II-A S	Drill hole diameter	Drill hole depth	Mortar volume in scale units shown on the cartridge labels' corresponding scale	Anchor per cartridge FIS HB 360 S ^{*)}
Type	[mm]	[mm]		
FHB II-A S M10 x 60	10	75	3	56
FHB II-A S M10 x 75	10	90	4	42
FHB II-A S M12 x 75	12	90	4	42
FHB II-A S M16 x 95	16	110	8	21
FHB II-A S M20 x 170	25	190	26	6
FHB II-A S M24 x 170	25	190	26	6

*) Max. number with one static mixer.

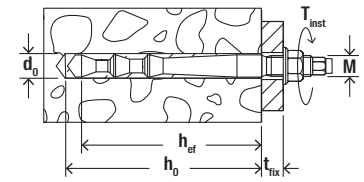

Technical data

Highbond anchor FHB II-A L



FHB II-A L (long version)

Item	Zinc-plated steel	Stainless steel	Highly corrosion resistant steel	Approval	Drill hole diameter	Drill hole depth	Anchorage depth	Usable length	Thread	Width across nut	Sales unit
	Item No. gvz	Item No. R	Item No. HCR	ETA	d_0 [mm]	h_0 [mm]	h_{ef} [mm]	t_{fix} [mm]	M	SW [mm]	[pcs]
FHB II-A L M8 x 60/10	097032	097298	097696 ¹⁾	●	10	75	60	10	M 8	13	10
FHB II-A L M8 x 60/30	097033	097299	—	●	10	75	60	30	M 8	13	10
FHB II-A L M8 x 60/50	097034	097440	—	●	10	75	60	50	M 8	13	10
FHB II-A L M10 x 95/10	096907	097616	—	●	12	110	95	10	M 10	17	10
FHB II-A L M10 x 95/20	096940	097617	097699 ¹⁾	●	12	110	95	20	M 10	17	10
FHB II-A L M10 x 95/40	—	097618	—	●	12	110	95	40	M 10	17	10
FHB II-A L M10 x 95/60	096941	097619	—	●	12	110	95	60	M 10	17	10
FHB II-A L M10 x 95/100	096942	097620	—	●	12	110	95	100	M 10	17	10
FHB II-A L M12 x 100/10	506893	506897	—	●	14	115	100	10	M 12	19	10
FHB II-A L M12 x 100/25	506894	506898	—	●	14	115	100	25	M 12	19	10
FHB II-A L M12 x 100/40	—	506899	—	●	14	115	100	40	M 12	19	10
FHB II-A L M12 x 100/50 GS	—	537065	—	●	14	115	100	50	M 12	19	10
FHB II-A L M12 x 100/60	506895	506901	—	●	14	115	100	60	M 12	19	10
FHB II-A L M12 x 100/100	506896	506902	—	●	14	115	100	100	M 12	19	10
FHB II-A L M12 x 120/10	096943	097621	—	●	14	135	120	10	M 12	19	10
FHB II-A L M12 x 120/25	096944	097622	097700 ¹⁾	●	14	135	120	25	M 12	19	10
FHB II-A L M12 x 120/40	—	097623	—	●	14	135	120	40	M 12	19	10
FHB II-A L M12 x 120/60	097014	097624	—	●	14	135	120	60	M 12	19	10
FHB II-A L M12 x 120/100	097031	097625	—	●	14	135	120	100	M 12	19	10
FHB II-A L M16 x 125/30	506903	506906	—	●	18	140	125	30	M 16	24	10
FHB II-A L M16 x 125/60	506904	506909	—	●	18	140	125	60	M 16	24	10
FHB II-A L M16 x 125/100	506905	506910	—	●	18	140	125	100	M 16	24	10
FHB II-A L M16 x 145/30	506911	506914	—	●	18	160	145	30	M 16	24	10
FHB II-A L M16 x 145/60	506912	506915	—	●	18	160	145	60	M 16	24	10
FHB II-A L M16 x 145/100	506913	506916	—	●	18	160	145	100	M 16	24	10
FHB II-A L M16 x 160/30	097035	097626	097702 ¹⁾	●	18	175	160	30	M 16	24	10
FHB II-A L M16 x 160/60	097038	097627	—	●	18	175	160	60	M 16	24	10
FHB II-A L M16 x 160/100	097070	097628	—	●	18	175	160	100	M 16	24	10
FHB II-A L M20 x 210/50	097071	097629	097703 ¹⁾	●	25	235	210	50	M 20	30	4
FHB II-A L M20 x 210/150	052370	—	—	●	25	235	210	150	M 20	30	8
FHB II-A L M20 x 210/200	552056	—	—	●	25	235	210	200	M 20	30	8
FHB II-A L M24 x 210/50	506920	506921	—	●	25	235	210	50	M 24	36	4

¹⁾ Delivery time on request.

Filling quantities

FHB II-A L	Drill hole diameter	Drill hole depth	Mortar volume in scale units shown on the cartridge labels' corresponding scala	Anchor per cartridge FIS HB 360 S ^{*)}
Type	[mm]	[mm]		
FHB II-A L M8 x 60	10	75	3	56
FHB II-A L M10 x 95	12	110	5	34
FHB II-A L M12 x 100	14	115	7	24
FHB II-A L M12 x 120	14	135	7	24
FHB II-A L M16 x 125	18	140	11	15
FHB II-A L M16 x 145	18	160	13	13
FHB II-A L M16 x 160	18	175	13	13
FHB II-A L M20 x 210	25	235	33	5
FHB II-A L M24 x 210	25	235	33	5

*) Max. number with one static mixer.

3

Loads

Highbond-Anchor FHB II

Permissible loads of a single anchor^{1) 2)} in normal concrete of strength class C20/25.
For the design the complete current assessment ETA-05/0164 has to be considered.

Type	Material / surface ³⁾	Effective anchorage depth h_{ef} [mm]	Minimum member thickness h_{min} [mm]	Installation torque T_{inst} [Nm]	Cracked concrete				Non-cracked concrete			
					Permissible tension (N_{perm}) and shear loads (V_{perm}); minimum spacing (s_{min}) and edge distances (c_{min}) with reduced loads				Permissible tension (N_{perm}) and shear loads (V_{perm}); minimum spacing (s_{min}) and edge distances (c_{min}) with reduced loads			
					$N_{perm}^{4)}$ [kN]	$V_{perm}^{4)}$ [kN]	$s_{min}^{4)}$ [mm]	$c_{min}^{4)}$ [mm]	$N_{perm}^{4)}$ [kN]	$V_{perm}^{4)}$ [kN]	$s_{min}^{4)}$ [mm]	$c_{min}^{4)}$ [mm]
FHB II-A L M8 x 60	gvz	60	100	15	7.6	7.8	40	40	10.9	7.8	40	40
	R	60	100	15	7.6	8.7	40	40	10.9	8.7	40	40
	HCR	60	100	15	7.6	8.7	40	40	10.9	8.7	40	40
FHB II-A S M10 x 60	gvz	60	100	15	7.6	11.3	40	40	10.9	11.3	40	40
	R	60	100	15	7.6	13.8	40	40	10.9	13.8	40	40
	HCR	60	100	15	7.6	13.8	40	40	10.9	13.8	40	40
FHB II-A S M10 x 75	gvz	75	120	15	10.7	11.3	40	40	12.0	11.3	40	40
	R	75	120	15	10.7	13.8	40	40	12.0	13.8	40	40
FHB II-A L M10 x 95	gvz	95	140	20	15.2	11.9	40	40	16.4	11.9	40	40
	R	95	140	20	15.2	13.3	40	40	16.4	13.3	40	40
	HCR	95	140	20	15.2	13.3	40	40	16.4	13.3	40	40
FHB II-A S M12 x 75	gvz	75	120	30	10.7	15.6	40	40	15.2	15.6	40	40
	R	75	120	30	10.7	19.3	40	40	15.2	19.3	40	40
	HCR	75	120	30	10.7	19.3	40	40	15.2	19.3	40	40
FHB II-A L M12 x 100	gvz	100	140	40	16.4	17.3	50	50	23.4	17.3	50	50
	R	100	140	40	16.4	19.3	50	50	23.4	19.3	50	50
FHB II-A L M12 x 120	gvz	120	170	40	21.6	17.3	50	50	23.7	17.3	50	50
	R	120	170	40	21.6	19.3	50	50	23.7	19.3	50	50
	HCR	120	170	40	21.6	19.3	50	50	23.7	19.3	50	50
FHB II-A S M16 x 95	gvz	95	150	50	15.2	29.0	50	50	21.7	29.0	50	50
	R	95	150	50	15.2	30.4	50	50	21.7	35.8	50	50
	HCR	95	150	50	15.2	30.4	50	50	21.7	35.8	50	50
FHB II-A L M16 x 125	gvz	125	170	60	22.9	32.2	55	55	32.7	32.2	55	55
	R	125	170	60	22.9	35.8	55	55	32.7	35.8	55	55
FHB II-A L M16 x 145	gvz	145	190	60	28.6	32.2	60	60	40.9	32.2	60	60
	R	145	190	60	28.6	35.8	60	60	40.9	35.8	60	60
FHB II-A L M16 x 160	gvz	160	220	60	33.2	32.2	70	70	46.0	32.2	70	70
	R	160	220	60	33.2	35.8	70	70	46.0	35.8	70	70
	HCR	160	220	60	33.2	35.8	70	70	46.0	35.8	70	70
FHB II-A S M20 x 170	gvz	170	240	100	36.3	45.9	80	80	51.9	45.9	80	80
	R	170	240	100	36.3	55.9	80	80	51.9	55.9	80	80
FHB II-A L M20 x 210	gvz	210	280	100	49.9	50.2	90	90	65.5	50.2	90	90
	R	210	280	100	49.9	55.9	90	90	65.5	55.9	90	90
	HCR	210	280	100	49.9	55.9	90	90	65.5	55.9	90	90
FHB II-A S M24 x 170	gvz	170	240	100	36.3	65.3	80	80	51.9	65.3	80	80
	R	170	240	100	36.3	71.1	80	80	51.9	71.1	80	80
	HCR	170	240	100	36.3	72.7	80	80	51.9	80.6	80	80
FHB II-A L M24 x 210	gvz	210	280	100	49.9	72.5	90	90	65.5	72.5	90	90
	R	210	280	100	49.9	80.6	90	90	65.5	80.6	90	90

¹⁾ Design according to EN 1992-4:2018 (for static resp. quasi-static loads). The partial safety factors for material resistance as regulated in the ETA as well as a partial safety factor for load actions of $\gamma_L = 1.4$ are considered. As a single anchor counts e.g. an anchor with a spacing $s \geq 3 \times h_{ef}$ and an edge distance $c \geq 1.5 \times h_{ef}$. Accurate data see ETA.

²⁾ The specified loads are valid for anchorages in dry and damp concrete. For temperatures in the anchoring substrate up to 50 °C (resp. short term up to 80 °C). Drill hole cleaning as per specification in the ETA.

³⁾ Further steel grades, versions and technical data see ETA, e.g. for dry internal conditions, galvanised steel (gvz); for damp interiors and for outdoor use, stainless steel (R).

⁴⁾ In the case of combinations of tension and shear loads, bending moments with reduced or minimum spacing and edge distances (anchor groups), the design must be carried out in accordance with the provisions of the complete ETA and the provisions of the EN 1992-4:2018. We recommend using our anchor design software C-FIX.

Highbond system FHB II Inject

The economical solution in cracked concrete

3



Bridge railings



Steel constructions

Applications

- Bridge railings
- Façades
- Staircases
- Steel constructions
- Masts

Advantages

- The Highbond system FHB II Inject achieves high load values in cracked concrete.
- The combination of injection mortar FIS HB and anchor rod FHB II-AS Inject R (short version) or FHB II-AL Inject R (long version) is ideally suited for serial installa-

tion outdoors.

- The low drill hole depth minimizes the drilling effort, which saves time and ensures economical installation.
- When using hollow drills with extraction, no drill hole cleaning is required.

Certificates



ETA-16/0637, for cracked concrete

Building materials

Approved for:

- Concrete C20/25 to C50/60, cracked and non-cracked

Also suitable for:

- Concrete C12/15

Versions

- Stainless steel

Functioning

- The FHB II Inject is a bonded anchor with torque-controlled expansion for pre-positioned and push-through installation.
- For FHB II-AL Inject, the annular gap must be filled with Highbond special mortar FIS HB in case of push-through installation.
- The anchor rod is set with the Highbond special motor FIS HB and is fully bonded in the drill hole.
- When tightening the hexagon nut, the anchor rod cones are pulled in the mortar shell, which expands against the drill hole wall.

For use with

Dispenser page 189



Accessories page

194



Pre-positioned installation in concrete with FIS HB

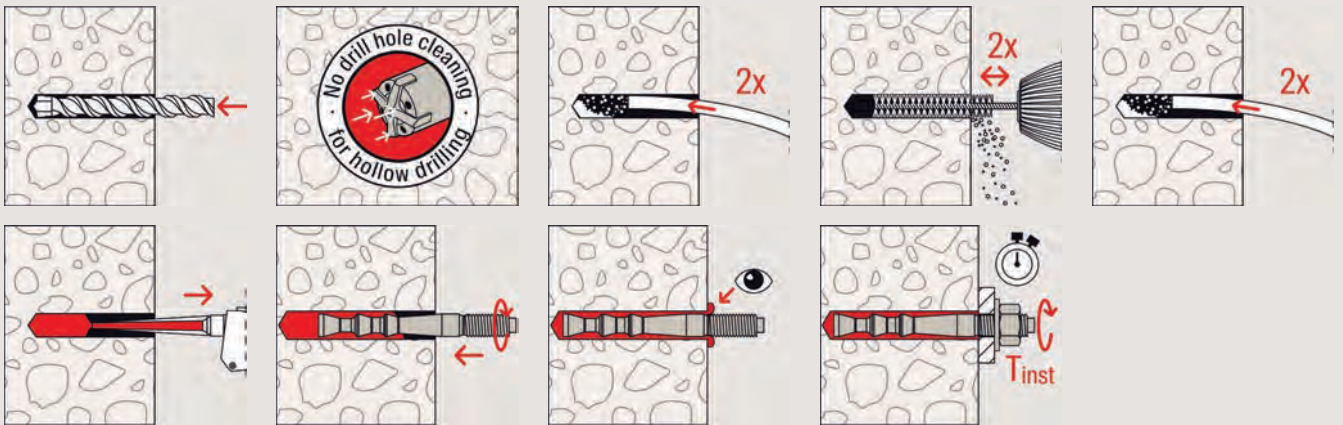

3

Push-through installation in concrete with FIS HB

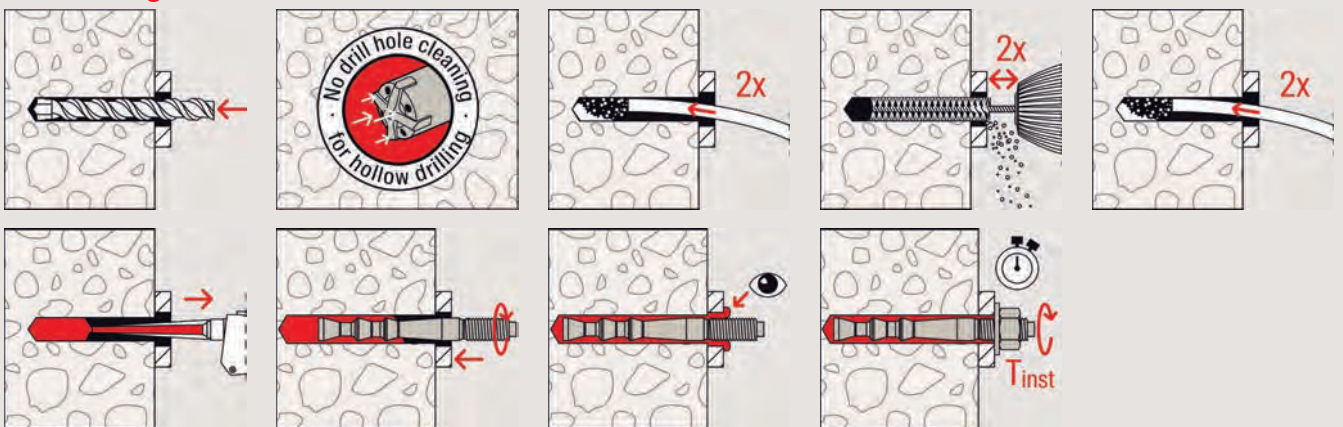

Technical data

Injection mortar FIS HB



FIS HB 360 S + FIS MR Plus

FIS HB 150 C

Item	Item No.	Approval ETA	Languages on the cartridge	Scale unit	Contents	Sales unit [pcs]
FIS HB 360 S	519125	●	DE	180	1 cartridge 360 ml, 2 x FIS MR Plus	6
FIS HB 360 S	562659	●	DE, FR, IT, NL	180	1 cartridge 360 ml, 2 x FIS MR Plus	6
FIS HB 360 S	562658	●	EN, ZH	180	1 cartridge 360 ml, 2 x FIS MR Plus	6
FIS HB 360 S	562660	●	EN, PL, RU, CS, SK	180	1 cartridge 360 ml, 2 x FIS MR Plus	6
FIS HB 360 S	562661	●	EN, ES, PT, EL	180	1 cartridge 360 ml, 2 x FIS MR Plus	6
FIS HB 150 C	519665	●	DE, FR, NL	70	1 cartridge 145 ml, 2 x FIS MR Plus	6
FIS MR Plus	545853	—	—	—	10 static mixer FIS MR Plus	10

Curing times

FIS HB System temperature FIS HB (Mortar min. +5 °C) [°C]	Maximum processing time FIS HB t_{work} [min.]	Minimum curing time FIS HB ¹⁾ t_{cure} [min.]
-5 - -1	-	360
0 - +4	-	180
> +5 - +9	15	90
> +10 - +19	6	35
> +20 - +29	4	20
> +30 - +40	2	12

1) In wet concrete the curing times must be doubled.

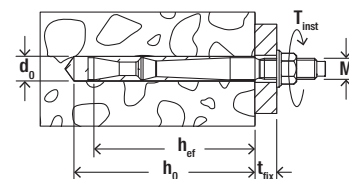

Technical data

Highbond anchor FHB II-A S Inject



FHB II-A S Inject R (short version)

Item	Stainless steel	Approval ETA	Drill hole diameter	Drill hole depth	Anchorage depth	Total length	Usable length	Width across nut	Sales unit
	Item No.		d_0 [mm]	h_0 [mm]	h_{ef} [mm]	l [mm]	t_{fix} [mm]	SW [mm]	[pcs]
FHB II-A S Inject M10 x 60/10 R	539911	●	10	66	60	90	10	17	10
FHB II-A S Inject M10 x 60/20 R	539912	●	10	66	60	100	20	17	10
FHB II-A S Inject M10 x 60/30 R	539927	●	10	66	60	110	30	17	10
FHB II-A S Inject M10 x 60/40 R	539913	●	10	66	60	120	40	17	10
FHB II-A S Inject M10 x 60/60 R	554092	●	10	66	60	—	60	17	10
FHB II-A S Inject M10 x 60/100 R	539914	●	10	66	60	180	100	17	10
FHB II-A S Inject M12 x 75/25 R	539928	●	12	81	75	123	25	19	10
FHB II-A S Inject M12 x 75/40 R	561037	●	12	81	75	138	40	19	10
FHB II-A S Inject M12 x 75/50 R	539929	●	12	81	75	148	50	19	10
FHB II-A S Inject M16 x 95/30 R	539920	●	16	101	95	150	30	24	10
FHB II-A S Inject M16 x 95/60 R	539921	●	16	101	95	180	60	24	10

Filling quantities

FHB II-A S Inject Type	Drill hole diameter [mm]	Drill hole depth [mm]	Mortar volume in scale units shown on the cartridge labels* corresponding scale	Anchor per cartridge FIS HB 360 S ^{*)}
FHB II-A S Inject M10 x 60	10	75	3	56
FHB II-A S Inject M12 x 75	12	90	4	42
FHB II-A S Inject M16 x 95	16	110	8	21

*) Max. number with one static mixer.

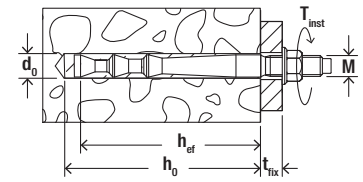

Technical data

Highbond anchor FHB II-A L Inject



FHB II-A L Inject R (long version)

Item	Stainless steel Item No.	Approval ETA	Drill hole diameter d_0 [mm]	Drill hole depth h_0 [mm]	Anchorage depth h_{ef} [mm]	Total length l [mm]	Usable length t_{fix} [mm]	Width across nut SW [mm]	Sales unit [pcs]
FHB II-A L Inject M10 x 95/10 R	539916	●	12	101	95	125	10	17	10
FHB II-A L Inject M10 x 95/20 R	539917	●	12	101	95	135	20	17	10
FHB II-A L Inject M12 x 100/25 R	539918	●	14	106	100	148	25	19	10
FHB II-A L Inject M12 x 120/25 R	539919	●	14	126	120	160	25	19	10
FHB II-A L Inject M16 x 125/30 R	539922	●	18	131	125	180	30	24	10
FHB II-A L Inject M16 x 125/60 R	539923	●	18	131	125	210	60	24	10
FHB II-A L Inject M16 x 160/30 R	539925	●	18	166	160	215	30	24	10
FHB II-A L Inject M16 x 160/60 R	539926	●	18	166	160	245	60	24	10

Filling quantities

FHB II-A L Inject Type	Drill hole diameter [mm]	Drill hole depth [mm]	Mortar volume in scale units shown on the cartridge labels* corresponding scala	Anchor per cartridge FIS HB 360 S ^{*)}
FHB II-A L Inject M10 x 95	12	110	5	34
FHB II-A L Inject M12 x 100	14	115	6	24
FHB II-A L Inject M12 x 120	14	135	7	24
FHB II-A L Inject M16 x 125	18	140	11	15
FHB II-A L Inject M16 x 160	18	175	13	13

*) Max. number with one static mixer.

Loads

Highbond-Anchor FHB II Inject

Permissible loads of a single anchor^{1) 2)} in normal concrete of strength class C20/25.
For the design the complete current assessment ETA-16/0637 has to be considered.

Type	Material / surface ³⁾	Effective anchor-age depth h_{ef} [mm]	Minimum member thickness h_{min} [mm]	Installation torque T_{inst} [Nm]	Cracked concrete				Non-cracked concrete			
					Permissible tension (N_{perm}) and shear loads (V_{perm}); minimum spacing (s_{min}) and edge distances (c_{min}) with reduced loads				Permissible tension (N_{perm}) and shear loads (V_{perm}); minimum spacing (s_{min}) and edge distances (c_{min}) with reduced loads			
					$N_{perm}^{4)}$ [kN]	$V_{perm}^{4)}$ [kN]	$s_{min}^{4)}$ [mm]	$c_{min}^{4)}$ [mm]	$N_{perm}^{4)}$ [kN]	$V_{perm}^{4)}$ [kN]	$s_{min}^{4)}$ [mm]	$c_{min}^{4)}$ [mm]
FHB II-A S Inject M10 x 60	R	60	100	15	7.6	13.8	40	40	10.9	13.8	40	40
FHB II-A L Inject M10 x 95	R	95	140	20	15.2	13.3	40	40	16.4	13.3	40	40
FHB II-A S Inject M12 x 75	R	75	120	30	10.7	19.3	40	40	15.2	19.3	40	40
FHB II-A L Inject M12 x 100	R	100	140	40	16.4	19.3	50	50	23.4	19.3	50	50
FHB II-A L Inject M12 x 120	R	120	170	40	21.6	19.3	50	50	23.7	19.3	50	50
FHB II-A S Inject M16 x 95	R	95	150	50	15.2	30.4	50	50	21.7	35.8	50	50
FHB II-A L Inject M16 x 125	R	125	170	60	22.9	35.8	55	55	32.7	35.8	55	55
FHB II-A L Inject M16 x 160	R	160	220	60	33.2	35.8	70	70	46.0	35.8	70	70

¹⁾ Design according to EN 1992-4:2018 (for static resp. quasi-static loads). The partial safety factors for material resistance as regulated in the ETA as well as a partial safety factor for load actions of $\gamma_L = 1.4$ are considered. As a single anchor counts e.g. an anchor with a spacing $s \geq 3 \times h_{ef}$ and an edge distance $c \geq 1.5 \times h_{ef}$. Accurate data see ETA.

²⁾ The specified loads are valid for anchorages in dry and damp concrete. For temperatures in the anchoring substrate up to 50 °C (resp. short term up to 80 °C). Drill hole cleaning as per specification in the ETA.

³⁾ Further steel grades, versions and technical data see ETA, e.g. for dry internal conditions, galvanised steel (gvz); for damp interiors and for outdoor use, stainless steel (R).

⁴⁾ In the case of combinations of tension and shear loads, bending moments with reduced or minimum spacing and edge distances (anchor groups), the design must be carried out in accordance with the provisions of the complete ETA and the provisions of the EN 1992-4:2018. We recommend using our anchor design software C-FIX.

Superbond system FSB

The concrete all-rounder



Bridges for traffic signs



Steel girders

3

Applications

- Heavy steel constructions
- Silo installations
- Tall shelving
- Sound barriers
- Guard rails
- Staircases
- Reinforcing steel (only FIS SB)
- Overhead installations
- Water-filled drill holes
- Diamond drilled holes

Advantages

- The Superbond system is a combined capsule and injection system for cracked and non-cracked concrete. The injection mortar FIS SB and resin capsule RSB perform the same as each other at the same anchorage depth. This gives the installer maximum flexibility.
- Variable anchorage depths from $4 \times d_s$ to $20 \times d_s$ enable ideal adaptation to the load to be applied, and thus ensure an optimised installation time and use of

materials.

- Maximum application temperatures of up to $+150\text{ °C}$ open up new areas of use for bonded anchors.
- Superbond is even approved for installation at frosty temperatures of -30 °C .
- The approval-compliant use for seismic applications (performance category C1, C2) as well as in waterfilled and diamond drill holes ensures safety even in extreme conditions.

Certificates



ETA-12/0258, for cracked concrete
 ETA-13/0651, for post-installed rebar connection
 ETA-19/0501, for concrete under fatigue cyclic loading



Fire resistance classification
 R120



Building materials

Approved for anchorings in:

- Concrete C20/25 to C50/60, cracked and non-cracked

Also suitable for:

- Natural stone with dense structure

Functioning

- Superbond is a bonded anchor system based on a vinyl ester hybrid with silane technology.
- The threaded rod FIS A can only be set with injection mortar FIS SB (Standard and HIGH SPEED); the threaded rod RG M with oblique edge can be optionally set with injection mortar FIS SB (Standard and HIGH SPEED) or resin capsule RSB.
- Resin and hardener are stored in two separate chambers and are not mixed and activated until extrusion through the injection cartridge in the static mixer or destruction of the capsule during the setting procedure.
- The mortar bonds the entire surface of the fastening element with the drill hole wall and seals the drill hole.

For use with

Anchors & sleeves page 126



Dispenser page 189



Accessories page 194



Installation in concrete with FIS SB and FIS A / RG M

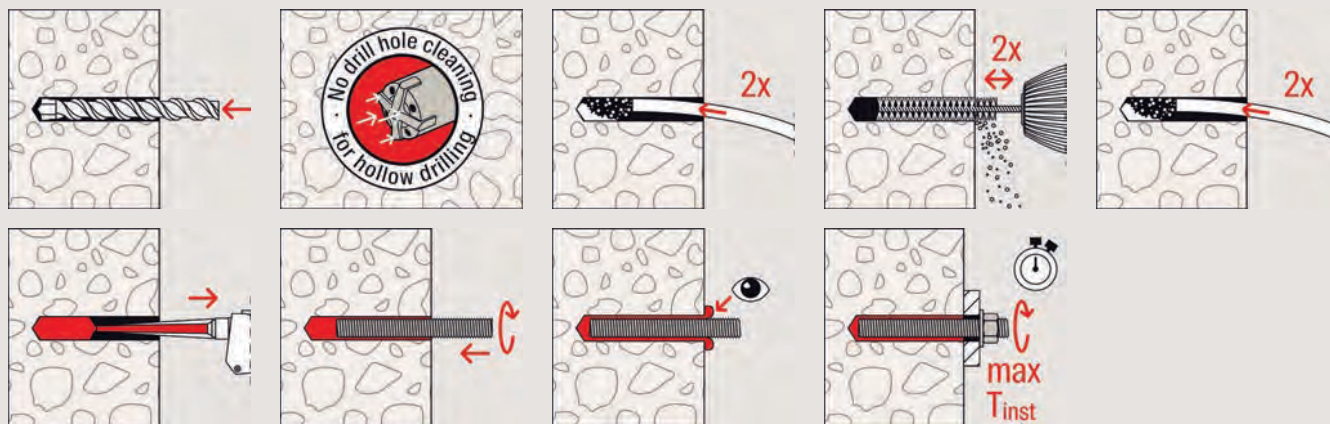

3

Installation in concrete with FIS SB and RG M I

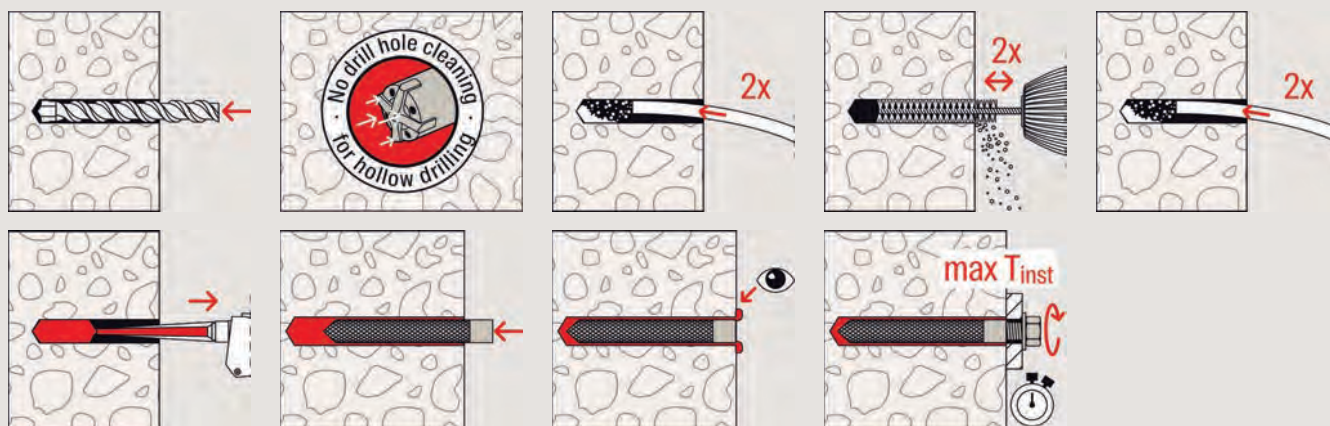

Technical data

Injection mortar FIS SB



FIS SB 390 S

FIS MR Plus

Item	Item No.	Approval		Languages on the cartridge	Scale unit	Contents	Sales unit [pcs]
		ETA	ICC				
FIS SB 390 S	519451	●	●	DE, FR, NL	180	1 cartridge 390 ml, 2 x FIS MR Plus	6
FIS SB 390 S	520557	●	●	DE, SL, SR, BG	180	1 cartridge 390 ml, 2 x FIS MR Plus	6
FIS SB 390 S	518831	●	●	EN, ES, PT	180	1 cartridge 390 ml, 2 x FIS MR Plus	6
FIS SB 390 S	519450	●	●	IT, DE, EN	180	1 cartridge 390 ml, 2 x FIS MR Plus	6
FIS SB 390 S	520559	●	●	DA, SV, NO, FI	180	1 cartridge 390 ml, 2 x FIS MR Plus	6
FIS SB 390 S	520555	●	●	CS, SK, RO	180	1 cartridge 390 ml, 2 x FIS MR Plus	6
FIS SB 390 S	520595	●	●	PL, RU, HU	180	1 cartridge 390 ml, 2 x FIS MR Plus	6
FIS SB 585 S	562065	●	●	FR, NL, DE	270	1 cartridge 585 ml + 2 x FIS UMR	6
FIS SB 585 S	519452	●	●	EN, ES, PT	270	1 cartridge 585 ml + 2 x FIS UMR	6
FIS SB 585 S	520526	●	●	IT, DE, EN	270	1 cartridge 585 ml + 2 x FIS UMR	6
FIS SB HIGH SPEED 390 S	523303	●	—	PL, RU, HU	180	1 cartridge 390 ml, 2 x FIS MR Plus	6
FIS MR Plus	545853	—	—	—	—	10 static mixer FIS MR Plus	10
FIS UMR	520593	—	—	—	—	10 static mixer for 585 ml and 1500 ml cartridges	10

Technical data

Injection mortar FIS SB



FIS SB 390 S HWK big



FIS SB 390 S in bucket

Item	Item No.	Approval		Languages on the cartridge	Contents	Sales unit [pcs]
		ETA	ICC			
FIS SB 390 S HWK big	540252	●	●	EN, ES, PT	20 cartridges 390 ml, 40 x FIS MR Plus	1
FIS SB 390 S HWK big	520573	●	●	IT, DE, EN	20 cartridges 390 ml, 40 x FIS MR Plus	1
FIS SB 390 S in bucket	540750	●	●	EN, ES, PT	18 cartridges 390 ml, 36 x FIS MR Plus	1

Curing times

FIS SB Temperature in anchoring base [°C]	Maximum processing time FIS SB t_{work} [min.]	Maximum processing time FIS SB High Speed t_{work} [min.]	Minimum curing time FIS SB t_{cure}		Minimum curing time FIS SB High Speed t_{cure}	
			[hrs.]	[min.]	[hrs.]	[min.]
> -20 – -15	-	60	-	-	24	-
> -15 – -10	60	30	36	-	8	-
> -10 – -5	30	15	24	-	-	180
> -5 – 0	20	10	8	-	-	120
> +0 – +5	13	5	4	-	-	60
> +5 – +10	9	3	-	120	-	45
> +10 – +20	5	2	-	60	-	30
> +20 – +30	4	1	-	45	-	15
> +30 – +40	2	-	-	30	-	-

1) Minimum cartridge temperature +5°C

Installation in concrete with capsule RSB and RG M

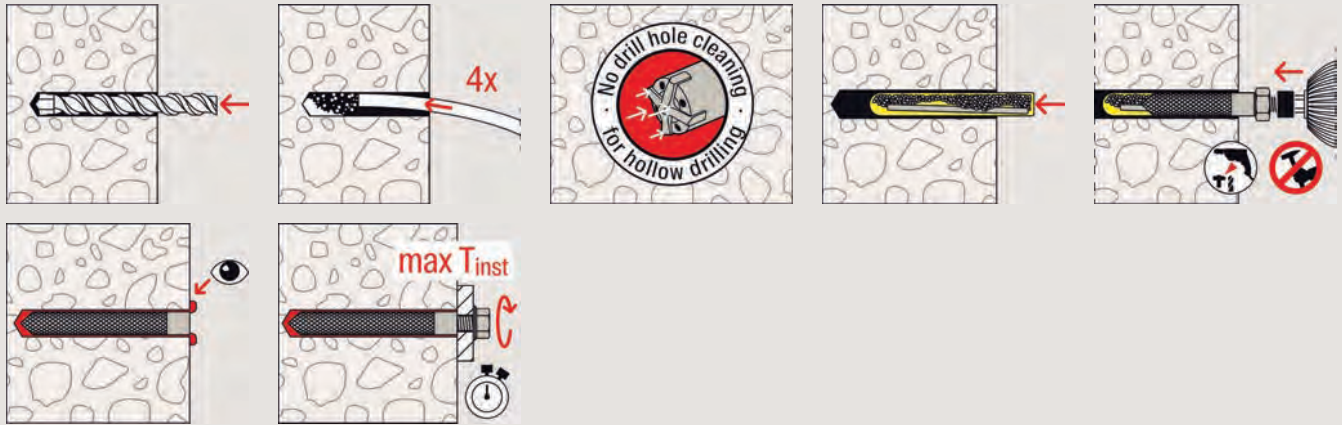

3

Installation in concrete with capsule RSB and RG M I

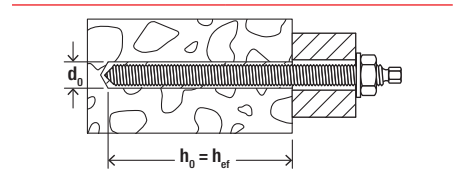
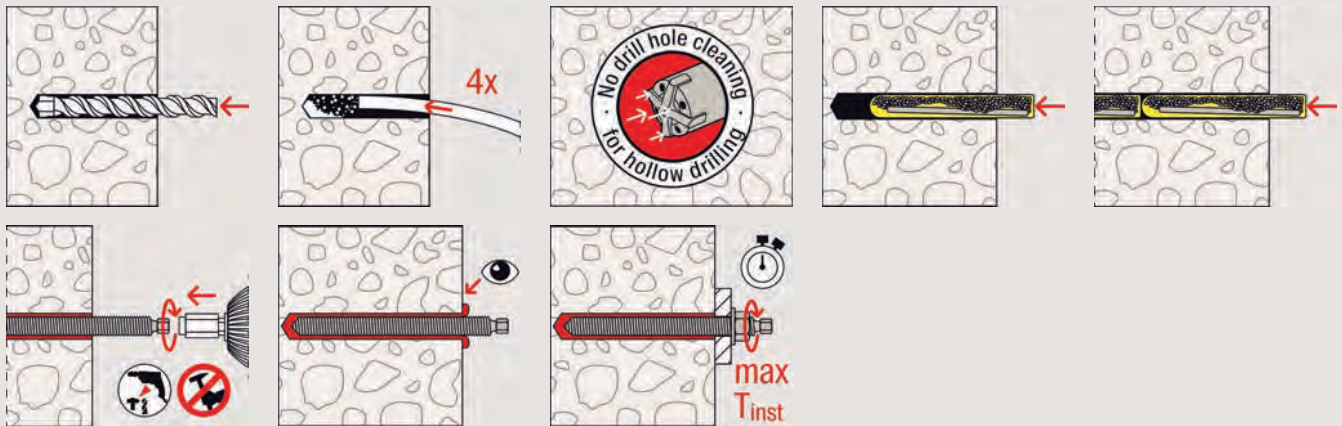

Technical data

Resin capsule RSB



RSB

Item	Item No.	Approval		Drill hole diameter d_0 [mm]	Drill hole depth h_0 [mm]	Anchorage depth h_{ef} [mm]	Match	Sales unit [pcs]
		ETA	ICC					
RSB 8	518807	●	●	10	80	80	RG M 8	10
RSB 10 mini	518820 ¹⁾	●	●	12	75 / 150	75 / 150	RG M 10	10
RSB 10	518821 ²⁾	●	●	12 / 14	90	90	RG M 10 / RG M 8 I	10
RSB 12 mini	518822 ¹⁾	●	●	14	75 / 150	75 / 150	RG M 12	10
RSB 12	518823 ²⁾	●	●	14 / 18	110	110	RG M 12 / RG M 10 I	10
RSB 16 mini	518824 ¹⁾	●	●	18	95 / 190	95 / 190	RG M 16	10
RSB 16	518825 ²⁾	●	●	18 / 20	125	125	RG M 16 / RG M 12 I	10
RSB 16 E	518826	●	—	24	160	160	RG M 16 I	10
RSB 20	518827	●	●	25	170	170	RG M 20	10
RSB 20 E/24	518828	●	●	25 / 28 / 32	210	210	RG M 20 / RG M 24 / RG M 20 I	5
RSB 30	518829	●	●	35	280	280	RG M 30	5

1) use 2 x RSB mini in a row for larger anchoring depth

2) / second value "Drill hole diameter" in conjunction with Internal threaded anchor RG M I

Curing times

RSB Temperature at anchoring base [°C]	Minimum curing time RSB	
	t_{cure} [hrs.]	[min.]
-30 – -20 ¹⁾	120	–
> -20 – -15	48	–
> -15 – -10	30	–
> -10 – -5	16	–
> -5 – 0	10	–
> +0 – +5	–	45
> +5 – +10	–	30
> +10 – +20	–	20
> +20 – +30	–	5
> +30 – +40	–	3

1) Minimum resin capsule temperature -15°C

Loads

Superbond-System: Injection mortar FIS SB with internal threaded anchor RG M I

Permissible loads of a single anchor^{1) 2)} in normal concrete of strength class C20/25.
For the design the complete current assessment ETA-12/0258 has to be considered.

Type	Screw material ³⁾	Effective anchorage depth h_{ef} [mm]	Minimum member thickness h_{min} [mm]	Maximum installation-torque $T_{\text{inst,max}}$ [Nm]	Cracked concrete				Non-cracked concrete			
					Permissible tension (N_{perm}) and shear loads (V_{perm}); minimum spacing (s_{min}) and edge distances (c_{min}) with reduced loads				Permissible tension (N_{perm}) and shear loads (V_{perm}); minimum spacing (s_{min}) and edge distances (c_{min}) with reduced loads			
					N_{perm} ⁴⁾ [kN]	V_{perm} ⁴⁾ [kN]	s_{min} ⁴⁾ [mm]	c_{min} ⁴⁾ [mm]	N_{perm} ⁴⁾ [kN]	V_{perm} ⁴⁾ [kN]	s_{min} ⁴⁾ [mm]	c_{min} ⁴⁾ [mm]
RG M8 I	5.8	90	120	10	8.1	5.3	55	55	9.0	5.3	55	55
	8.8	90	120	10	8.1	8.3	55	55	13.8	8.3	55	55
	R-70	90	120	10	8.1	5.9	55	55	9.9	5.9	55	55
RG M10 I	5.8	90	130	20	10.8	8.3	65	65	13.8	8.3	65	65
	8.8	90	130	20	10.8	13.3	65	65	20.0	13.3	65	65
	R-70	90	130	20	10.8	9.3	65	65	15.7	9.3	65	65
RG M12 I	5.8	125	170	40	16.8	12.1	75	75	20.5	12.1	75	75
	8.8	125	170	40	16.8	19.3	75	75	32.4	19.3	75	75
	R-70	125	170	40	16.8	13.5	75	75	22.5	13.5	75	75
RG M16 I	5.8	160	210	80	26.3	22.4	95	95	37.6	22.4	95	95
	8.8	160	210	80	26.3	30.9	95	95	47.4	30.9	95	95
	R-70	160	210	80	26.3	25.1	95	95	42.0	25.1	95	95
RG M20 I	5.8	200	260	120	41.9	35.4	125	125	58.6	35.4	125	125
	8.8	200	260	120	41.9	51.4	125	125	66.3	51.4	125	125
	R-70	200	260	120	41.9	39.4	125	125	65.7	39.4	125	125

¹⁾ Design according to EN 1992-4:2018 (for static resp. quasi-static loads). The partial safety factors for material resistance as regulated in the ETA as well as a partial safety factor for load actions of $\gamma_L = 1.4$ are considered. As a single anchor counts e.g. an anchor with a spacing $s \geq 3 \times h_{\text{ef}}$ and an edge distance $c \geq 1.5 \times h_{\text{ef}}$. Accurate data see ETA.

²⁾ The specified loads are valid for anchorages in dry and damp concrete. For temperatures in the anchoring substrate up to 50 °C (resp. short term up to 80 °C). Drill hole cleaning as per specification in the ETA. The factor Ψ_{sus} for sustained load was taken into account with 1.0.

³⁾ Further steel grades, versions and technical data see ETA, e.g. for dry internal conditions, galvanised steel (gvz); for damp interiors and for outdoor use, stainless steel (R).

⁴⁾ In the case of combinations of tension and shear loads, bending moments with reduced or minimum spacing and edge distances (anchor groups), the design must be carried out in accordance with the provisions of the complete ETA and the provisions of the EN 1992-4:2018. We recommend using our anchor design software C-FIX.

Loads

Superbond-System: Injection mortar FIS SB with threaded rod FIS A or RG M

Permissible loads of a single anchor^{1) 2)} in normal concrete of strength class C20/25.
For the design the complete current assessment ETA-12/0258 has to be considered.

Type	Material/ surface ³⁾	Effective anchorage depth h_{ef} [mm]	Minimum member thickness h_{min} [mm]	Maximum installation- torque $T_{inst,max}$ [Nm]	Cracked concrete				Non-cracked concrete			
					Permissible tension (N_{perm}) and shear loads (V_{perm}); minimum spacing (s_{min}) and edge distances (c_{min}) with reduced loads				Permissible tension (N_{perm}) and shear loads (V_{perm}); minimum spacing (s_{min}) and edge distances (c_{min}) with reduced loads			
					$N_{perm}^{4)}$ [kN]	$V_{perm}^{4)}$ [kN]	$s_{min}^{4)}$ [mm]	$c_{min}^{4)}$ [mm]	$N_{perm}^{4)}$ [kN]	$V_{perm}^{4)}$ [kN]	$s_{min}^{4)}$ [mm]	$c_{min}^{4)}$ [mm]
FIS A M 8	5.8	60	100	10	4.3	6.3	40	40	8.6	6.3	40	40
	5.8	80	110	10	5.7	6.3	40	40	9.0	6.3	40	40
	5.8	160	190	10	9.0	6.3	40	40	9.0	6.3	40	40
	R-70	60	100	10	4.3	6.0	40	40	8.6	6.0	40	40
	R-70	80	110	10	5.7	6.0	40	40	9.9	6.0	40	40
	R-70	160	190	10	9.9	6.0	40	40	9.9	6.0	40	40
FIS A M 10	5.8	60	100	20	5.8	9.7	45	45	10.8	9.7	45	45
	5.8	90	120	20	8.8	9.7	45	45	13.8	9.7	45	45
	5.8	200	230	20	13.8	9.7	45	45	13.8	9.7	45	45
	R-70	60	100	20	5.8	9.2	45	45	10.8	9.2	45	45
	R-70	90	120	20	8.8	9.2	45	45	15.7	9.2	45	45
	R-70	200	230	20	15.7	9.2	45	45	15.7	9.2	45	45
FIS A M 12	5.8	70	100	40	9.4	14.3	55	55	13.7	14.3	55	55
	5.8	110	140	40	14.8	14.3	55	55	20.5	14.3	55	55
	5.8	240	270	40	20.5	14.3	55	55	20.5	14.3	55	55
	R-70	70	100	40	9.4	13.7	55	55	13.7	13.7	55	55
	R-70	110	140	40	14.8	13.7	55	55	22.5	13.7	55	55
	R-70	240	270	40	22.5	13.7	55	55	22.5	13.7	55	55
FIS A M 16	5.8	80	120	60	11.7	23.5	65	65	16.8	26.9	65	65
	5.8	125	170	60	22.4	26.9	65	65	32.7	26.9	65	65
	5.8	320	360	60	37.6	26.9	65	65	37.6	26.9	65	65
	R-70	80	120	60	11.7	23.5	65	65	16.8	25.2	65	65
	R-70	125	170	60	22.4	25.2	65	65	32.7	25.2	65	65
	R-70	320	360	60	42.0	25.2	65	65	42.0	25.2	65	65
FIS A M 20	5.8	90	140	120	14.0	28.0	85	85	20.0	40.0	85	85
	5.8	170	220	120	36.3	42.3	85	85	51.9	42.3	85	85
	5.8	400	450	120	58.6	42.3	85	85	58.6	42.3	85	85
	R-70	90	140	120	14.0	28.0	85	85	20.0	39.4	85	85
	R-70	170	220	120	36.3	39.4	85	85	51.9	39.4	85	85
	R-70	400	450	120	65.7	39.4	85	85	65.7	39.4	85	85
FIS A M 24	5.8	96	160	150	15.4	30.8	105	105	22.0	44.1	105	105
	5.8	210	270	150	49.9	60.6	105	105	71.3	60.6	105	105
	5.8	480	540	150	84.3	60.6	105	105	84.3	60.6	105	105
	R-70	96	160	150	15.4	30.8	105	105	22.0	44.1	105	105
	R-70	210	270	150	49.9	56.8	105	105	71.3	56.8	105	105
	R-70	480	540	150	94.3	56.8	105	105	94.3	56.8	105	105
FIS A M 30	5.8	120	190	300	21.6	43.1	140	140	30.8	61.6	140	140
	5.8	280	350	300	76.8	96.0	140	140	109.8	96.0	140	140
	5.8	600	670	300	133.8	96.0	140	140	133.8	96.0	140	140
	R-70	120	190	300	21.6	43.1	140	140	30.8	61.6	140	140
	R-70	280	350	300	76.8	90.2	140	140	109.8	90.2	140	140
	R-70	600	670	300	150.1	90.2	140	140	150.1	90.2	140	140

¹⁾ Design according to EN 1992-4:2018 (for static resp. quasi-static loads). The partial safety factors for material resistance as regulated in the ETA as well as a partial safety factor for load actions of $\gamma_1 = 1.4$ are considered. As a single anchor counts e.g. an anchor with a spacing $s \geq 3 \times h_{ef}$ and an edge distance $c \geq 1.5 \times h_{ef}$. Accurate data see ETA.

²⁾ The specified loads are valid for anchorages in dry and damp concrete. For temperatures in the anchoring substrate up to 50 °C (resp. short term up to 80 °C). Drill hole cleaning as per specification in the ETA. The factor Ψ_{sus} for sustained load was taken into account with 1.0.

³⁾ Further steel grades, versions and technical data see ETA, e.g. for dry internal conditions, galvanised steel (gvz); for damp interiors and for outdoor use, stainless steel (R).

⁴⁾ In the case of combinations of tension and shear loads, bending moments with reduced or minimum spacing and edge distances (anchor groups), the design must be carried out in accordance with the provisions of the complete ETA and the provisions of the EN 1992-4:2018. We recommend using our anchor design software C-FIX.

Loads

Superbond-System: Resin capsule RSB with threaded rod RG M

Permissible loads of a single anchor^{1) 2)} in normal concrete of strength class C20/25.
For the design the complete current assessment ETA-12/0258 has to be considered.

Type	Material/ surface ³⁾	Effective anchorage depth h_{ef} [mm]	Minimum member thickness h_{min} [mm]	Maximum installation- torque $T_{inst,max}$ [Nm]	Cracked concrete				Non-cracked concrete			
					Permissible tension (N_{perm}) and shear loads (V_{perm}); minimum spacing (s_{min}) and edge distances (c_{min}) with reduced loads				Permissible tension (N_{perm}) and shear loads (V_{perm}); minimum spacing (s_{min}) and edge distances (c_{min}) with reduced loads			
					$N_{perm}^{4)}$ [kN]	$V_{perm}^{4)}$ [kN]	$s_{min}^{4)}$ [mm]	$c_{min}^{4)}$ [mm]	$N_{perm}^{4)}$ [kN]	$V_{perm}^{4)}$ [kN]	$s_{min}^{4)}$ [mm]	$c_{min}^{4)}$ [mm]
RG M 8	5.8	80	110	10	5.7	6.3	40	40	9.0	6.3	40	40
	R-70	80	110	10	5.7	6.0	40	40	9.9	6.0	40	40
RG M 10	5.8	75	110	20	7.3	9.7	45	45	13.5	9.7	45	45
	5.8	90	120	20	8.8	9.7	45	45	13.8	9.7	45	45
	5.8	150	180	20	13.8	9.7	45	45	13.8	9.7	45	45
	R-70	75	110	20	7.3	9.2	45	45	13.5	9.2	45	45
	R-70	90	120	20	8.8	9.2	45	45	15.7	9.2	45	45
	R-70	150	180	20	14.6	9.2	45	45	15.7	9.2	45	45
RG M 12	5.8	75	110	40	10.1	14.3	55	55	15.2	14.3	55	55
	5.8	110	140	40	14.8	14.3	55	55	20.5	14.3	55	55
	5.8	150	180	40	20.2	14.3	55	55	20.5	14.3	55	55
	R-70	75	110	40	10.1	13.7	55	55	15.2	13.7	55	55
	R-70	110	140	40	14.8	13.7	55	55	22.5	13.7	55	55
	R-70	150	180	40	20.2	13.7	55	55	22.5	13.7	55	55
RG M 16	5.8	95	140	60	15.2	26.9	65	65	21.7	26.9	65	65
	5.8	125	170	60	22.4	26.9	65	65	32.7	26.9	65	65
	5.8	190	230	60	34.1	26.9	65	65	37.6	26.9	65	65
	R-70	95	140	60	15.2	25.2	65	65	21.7	25.2	65	65
	R-70	125	170	60	22.4	25.2	65	65	32.7	25.2	65	65
	R-70	190	230	60	34.1	25.2	65	65	42.0	25.2	65	65
RG M 20	5.8	170	220	120	36.3	42.3	85	85	51.9	42.3	85	85
	5.8	210	260	120	47.1	42.3	85	85	58.6	42.3	85	85
	R-70	170	220	120	36.3	39.4	85	85	51.9	39.4	85	85
	R-70	210	260	120	47.1	39.4	85	85	65.7	39.4	85	85
RG M 24	5.8	210	270	150	49.9	60.6	105	105	71.3	60.6	105	105
	R-70	210	270	150	49.9	56.8	105	105	71.3	56.8	105	105
RG M 30	5.8	280	350	300	76.8	96.0	140	140	109.8	96.0	140	140
	R-70	280	350	300	76.8	90.2	140	140	109.8	90.2	140	140

¹⁾ Design according to EN 1992-4:2018 (for static resp. quasi-static loads). The partial safety factors for material resistance as regulated in the ETA as well as a partial safety factor for load actions of $\gamma_L = 1.4$ are considered. As a single anchor counts e.g. an anchor with a spacing $s \geq 3 \times h_{ef}$ and an edge distance $c \geq 1.5 \times h_{ef}$. Accurate data see ETA.

²⁾ The specified loads are valid for anchorages in dry and damp concrete. For temperatures in the anchoring substrate up to 50 °C (resp. short term up to 80 °C). Drill hole cleaning as per specification in the ETA. The factor Ψ_{sus} for sustained load was taken into account with 1.0.

³⁾ Further steel grades, versions and technical data see ETA, e.g. for dry internal conditions, galvanised steel (gvz); for damp interiors and for outdoor use, stainless steel (R).

⁴⁾ In the case of combinations of tension and shear loads, bending moments with reduced or minimum spacing and edge distances (anchor groups), the design must be carried out in accordance with the provisions of the complete ETA and the provisions of the EN 1992-4:2018. We recommend using our anchor design software C-FIX.

Loads

Superbond-System: Resin capsule RSB with Internal threaded anchor RG M I

Permissible loads of a single anchor^{1) 2)} in normal concrete of strength class C20/25.
For the design the complete current assessment ETA-12/0258 has to be considered.

Type	Screw material ³⁾	Effective anchorage depth h_{ef} [mm]	Minimum member thickness h_{min} [mm]	Maximum installation-torque $T_{inst,max}$ [Nm]	Cracked concrete				Non-cracked concrete			
					Permissible tension (N_{perm}) and shear loads (V_{perm}); minimum spacing (s_{min}) and edge distances (c_{min}) with reduced loads				Permissible tension (N_{perm}) and shear loads (V_{perm}); minimum spacing (s_{min}) and edge distances (c_{min}) with reduced loads			
					$N_{perm}^{4)}$ [kN]	$V_{perm}^{4)}$ [kN]	$s_{min}^{4)}$ [mm]	$c_{min}^{4)}$ [mm]	$N_{perm}^{4)}$ [kN]	$V_{perm}^{4)}$ [kN]	$s_{min}^{4)}$ [mm]	$c_{min}^{4)}$ [mm]
RG M8 I	5.8	90	120	10	8.1	5.3	55	55	9.0	5.3	55	55
	8.8	90	120	10	8.1	8.3	55	55	13.8	8.3	55	55
	R-70	90	120	10	8.1	5.9	55	55	9.9	5.9	55	55
RG M10 I	5.8	90	130	20	10.8	8.3	65	65	13.8	8.3	65	65
	8.8	90	130	20	10.8	13.3	65	65	20.0	13.3	65	65
	R-70	90	130	20	10.8	9.3	65	65	15.7	9.3	65	65
RG M12 I	5.8	125	170	40	16.8	12.1	75	75	20.5	12.1	75	75
	8.8	125	170	40	16.8	19.3	75	75	32.4	19.3	75	75
	R-70	125	170	40	16.8	13.5	75	75	22.5	13.5	75	75
RG M16 I	5.8	160	210	80	26.3	22.4	95	95	37.6	22.4	95	95
	8.8	160	210	80	26.3	30.9	95	95	47.4	30.9	95	95
	R-70	160	210	80	26.3	25.1	95	95	42.0	25.1	95	95
RG M20 I	5.8	200	260	120	41.9	35.4	125	125	58.6	35.4	125	125
	8.8	200	260	120	41.9	51.4	125	125	66.3	51.4	125	125
	R-70	200	260	120	41.9	39.4	125	125	65.7	39.4	125	125

¹⁾ Design according to EN 1992-4:2018 (for static resp. quasi-static loads). The partial safety factors for material resistance as regulated in the ETA as well as a partial safety factor for load actions of $\gamma_L = 1.4$ are considered. As a single anchor counts e.g. an anchor with a spacing $s \geq 3 \times h_{ef}$ and an edge distance $c \geq 1.5 \times h_{ef}$. Accurate data see ETA.

²⁾ The specified loads are valid for anchorages in dry and damp concrete. For temperatures in the anchoring substrate up to 50 °C (resp. short term up to 80 °C). Drill hole cleaning as per specification in the ETA. The factor Ψ_{SUS} for sustained load was taken into account with 1.0.

³⁾ Further steel grades, versions and technical data see ETA, e.g. for dry internal conditions, galvanised steel (gvz); for damp interiors and for outdoor use, stainless steel (R).

⁴⁾ In the case of combinations of tension and shear loads, bending moments with reduced or minimum spacing and edge distances (anchor groups), the design must be carried out in accordance with the provisions of the complete ETA and the provisions of the EN 1992-4:2018. We recommend using our anchor design software C-FIX.

Resin anchor RM II

The bonded anchor for cracked concrete with threaded rod RG M without drill hole cleaning



Crash barriers

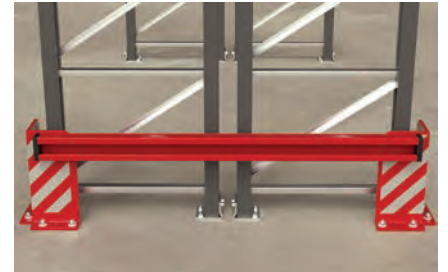

Collision protection

3

Applications

- Steel constructions
- Guard rails
- Staircases
- Column bases
- Machines
- Masts

Ideal for:

- Overhead installations
- Water-filled drill holes

Advantages

- RM II is the first bonded anchor with threaded rod RG M for cracked and non-cracked concrete that does not require drill hole cleaning. This allows for a rapid working progress and an economic installation.
- Moreover, there is a reduced exposition

- to drill dust on the building site. This increases the safety for the user.
- The pre-portioned resin capsule is easy to install and especially suitable for individual applications and overhead installations.

Certificates



ETA-16/0340, for cracked concrete



Fire resistance classification R120

Building materials

Approved for:

- Concrete C20/25 to C50/60, cracked and non-cracked

Also suitable for:

- Natural stone with dense structure

Versions

- Zinc-plated steel
- Stainless steel
- Highly corrosion-resistant steel
- Hot-dip galvanised steel

Functioning

- The resin anchor RM II is suitable for pre-positioned installation when combined with the threaded rod RG M.
- The 2-component resin capsule RM II contains styrene-free vinyl ester resin and hardener.
- The threaded rod RG M is set using a hammer drill and the accompanying setting tool in rotating and hitting motions.
- During setting, the oblique edge of the RG M destroys the capsule, and mixes and activates the mortar.
- The mortar bonds the entire surface of the threaded rod with the drill hole wall and seals the drill hole.

For use with

Anchors & sleeves page

137



Installation in concrete with capsule RM II and RG M

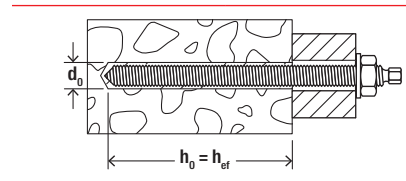
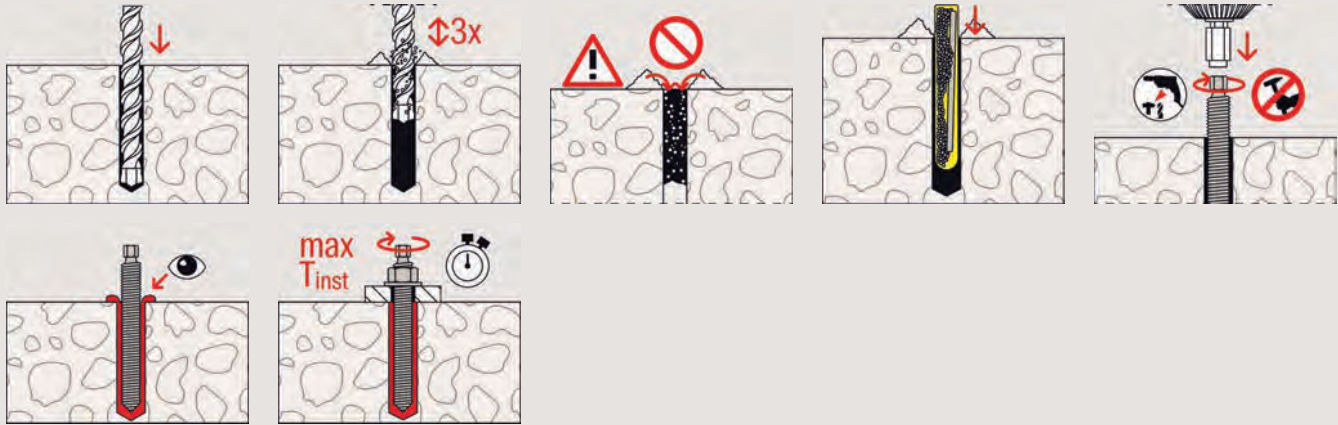

Technical data

Resin capsule RM II



RM II

Item	Item No.	Approval ETA	Drill hole diameter	Min. drill hole depth	Effect. anchorage depth	Suitable for threaded rod	Sales unit [pcs]
			d_0 [mm]	h_1 [mm]	h_{ef} [mm]		
RM II 8	539796	●	10	80	80	RG M 8	10
RM II 10	539797	●	12	90	90	RG M10	10
RM II 12	539798	●	14	110	110	RG M 12	10
RM II 14	539799	—	16	120	120	RG M 14	10
RM II 16	539800	●	18	125	125	RG M 16	10
RM II 20/22	539802 ¹⁾	●	25	170 / 190	170 / 190	RG M 20 / RG M 22	10
RM II 24	539803	●	28	210	210	RG M 24	5

1) RM II 20/22 in combination with RG M 22 and effect. anchorage depth of 190 mm is not part of the assessment.

Curing times

RM II Concrete temperature [°C]	Minimum curing time	
	t_{cure} [hrs.]	[min.]
-15 – -10	30	–
> -10 – -5	16	–
> -5 – 0	10	–
> 0 – +5	–	45
> +5 – +10	–	30
> +10 – +20	–	20
> +20 – +30	–	5
> +30 – +40	–	3

Installation in concrete with capsule RM II and RG M I

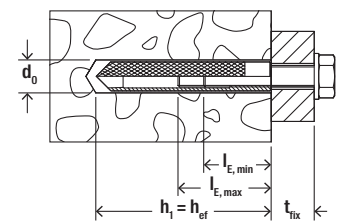
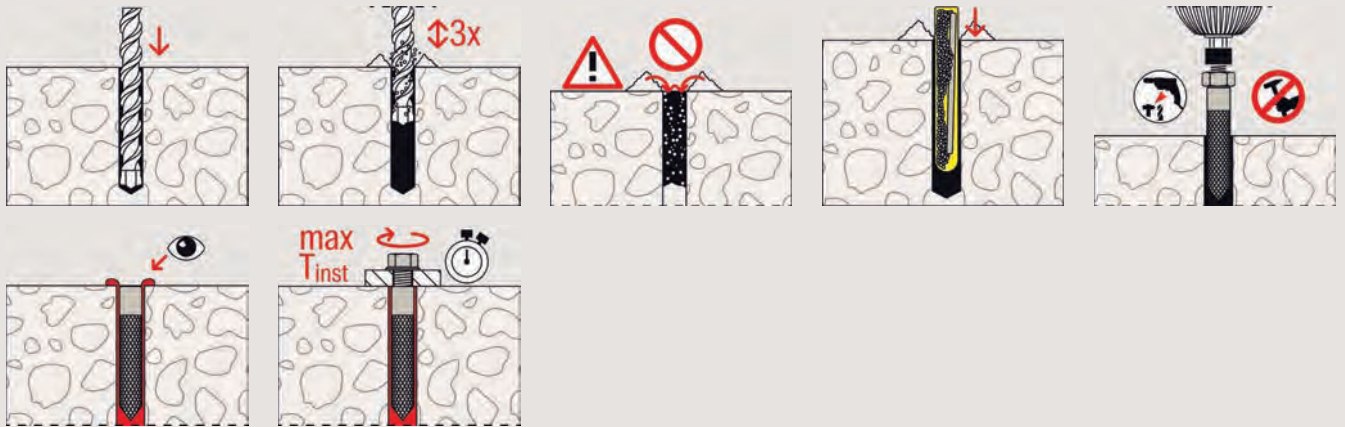

Technical data

Resin capsule RM II



RM II

Item	Item No.	Approval ETA	Drill diameter	Min. drill hole depth	Effect. anchorage depth	Suitable for internal-threaded anchor	Sales unit [pcs]
			d_0 [mm]	h_1 [mm]	h_{ef} [mm]		
RM II 10	539797	●	14	90	90	RG M8 I	10
RM II 12	539798	●	18	90	90	RG M10 I	10
RM II 16	539800	●	20	125	125	RG M12 I	10
RM II 16 E	539801	●	24	160	160	RG M16 I	10
RM II 24	539803	●	32	200	200	RG M20 I	5

Curing times

RM II Concrete temperature [°C]	Minimum curing time t_{cure}	
	[hrs.]	[min.]
-15 – -10	30	-
> -10 – -5	16	-
> -5 – 0	10	-
> 0 – +5	-	45
> +5 – +10	-	30
> +10 – +20	-	20
> +20 – +30	-	5
> +30 – +40	-	3

Loads

Resin capsule RM II with threaded rod RG M

Permissible loads of a single anchor^{1) 2)} in normal concrete of strength class C20/25.
For the design the complete current assessment ETA-16/0340 has to be considered.

Type	Material/ surface ³⁾	Effective anchorage depth h_{ef} [mm]	Minimum member thickness h_{min} [mm]	Maximum installation- torque $T_{inst,max}$ [Nm]	Cracked concrete				Non-cracked concrete			
					Permissible tension (N_{perm}) and shear loads (V_{perm}); minimum spacing (s_{min}) and edge distances (c_{min}) with reduced loads				Permissible tension (N_{perm}) and shear loads (V_{perm}); minimum spacing (s_{min}) and edge distances (c_{min}) with reduced loads			
					$N_{perm}^{4)}$ [kN]	$V_{perm}^{4)}$ [kN]	$s_{min}^{4)}$ [mm]	$c_{min}^{4)}$ [mm]	$N_{perm}^{4)}$ [kN]	$V_{perm}^{4)}$ [kN]	$s_{min}^{4)}$ [mm]	$c_{min}^{4)}$ [mm]
RG M 8	5.8	80	110	10	-	-	-	-	9.0	6.3	40	40
	R-70	80	110	10	-	-	-	-	9.6	6.0	40	40
RG M 10	5.8	90	120	20	4.5	9.7	45	45	13.5	9.7	45	45
	R-70	90	120	20	4.5	9.2	45	45	13.5	9.2	45	45
RG M 12	5.8	110	140	40	6.6	14.3	55	55	19.7	14.3	55	55
	R-70	110	140	40	6.6	13.7	55	55	19.7	13.7	55	55
RG M 16	5.8	125	170	60	10.0	23.9	65	65	27.3	26.9	65	65
	R-70	125	170	60	10.0	23.9	65	65	27.3	25.2	65	65
RG M 20	5.8	170	220	120	17.0	40.7	85	85	43.3	42.3	85	85
	R-70	170	220	120	17.0	39.4	85	85	43.3	39.4	85	85
RG M 24	5.8	210	270	150	25.1	60.3	105	105	59.4	60.6	105	105
	R-70	210	270	150	25.1	56.8	105	105	59.4	56.8	105	105

¹⁾ Design according to EN 1992-4:2018 (for static resp. quasi-static loads). The partial safety factors for material resistance as regulated in the ETA as well as a partial safety factor for load actions of $\gamma_L = 1.4$ are considered. As a single anchor counts e.g. an anchor with a spacing $s \geq 3 \times h_{ef}$ and an edge distance $c \geq 1.5 \times h_{ef}$. Accurate data see ETA.

²⁾ The specified loads are valid for anchorages in dry and damp concrete. For temperatures in the anchoring substrate up to 50 °C (resp. short term up to 80 °C). Drill hole cleaning as per specification in the ETA. The factor Ψ_{sus} for sustained load was taken into account with 1.0.

³⁾ Further steel grades, versions and technical data see ETA, e.g. for dry internal conditions, galvanised steel (gvz); for damp interiors and for outdoor use, stainless steel (R).

⁴⁾ In the case of combinations of tension and shear loads, bending moments with reduced or minimum spacing and edge distances (anchor groups), the design must be carried out in accordance with the provisions of the complete ETA and the provisions of the EN 1992-4:2018. We recommend using our anchor design software C-FIX.

Loads

Resin capsule RM II with internal threaded anchor RG M I

Permissible loads of a single anchor^{1) 2)} in normal concrete of strength class C20/25.
For the design the complete current assessment ETA-16/0340 has to be considered.

Type	Screw material ³⁾	Effective anchorage depth h_{ef} [mm]	Minimum member thickness h_{min} [mm]	Maximum installation- torque $T_{inst,max}$ [Nm]	Cracked concrete				Non-cracked concrete			
					Permissible tension (N_{perm}) and shear loads (V_{perm}); minimum spacing (s_{min}) and edge distances (c_{min}) with reduced loads				Permissible tension (N_{perm}) and shear loads (V_{perm}); minimum spacing (s_{min}) and edge distances (c_{min}) with reduced loads			
					$N_{perm}^{4)}$ [kN]	$V_{perm}^{4)}$ [kN]	$s_{min}^{4)}$ [mm]	$c_{min}^{4)}$ [mm]	$N_{perm}^{4)}$ [kN]	$V_{perm}^{4)}$ [kN]	$s_{min}^{4)}$ [mm]	$c_{min}^{4)}$ [mm]
RG M8 I	5.8	90	120	10	5.4	5.3	55	55	9.0	5.3	55	55
	8.8	90	120	10	5.4	8.3	55	55	13.8	8.3	55	55
	R-70	90	120	10	5.4	5.9	55	55	9.9	5.9	55	55
RG M10 I	5.8	90	130	20	7.2	8.3	65	65	13.8	8.3	65	65
	8.8	90	130	20	7.2	13.3	65	65	16.7	13.3	65	65
	R-70	90	130	20	7.2	9.3	65	65	15.7	9.3	65	65
RG M12 I	5.8	125	170	40	11.2	12.1	75	75	20.5	12.1	75	75
	8.8	125	170	40	11.2	19.3	75	75	27.3	19.3	75	75
	R-70	125	170	40	11.2	13.5	75	75	22.5	13.5	75	75
RG M16 I	5.8	160	210	80	17.6	22.4	95	95	37.6	22.4	95	95
	8.8	160	210	80	17.6	30.9	95	95	39.5	30.9	95	95
	R-70	160	210	80	17.6	25.1	95	95	39.5	25.1	95	95
RG M20 I	5.8	200	260	120	27.9	35.4	125	125	55.2	35.4	125	125
	8.8	200	260	120	27.9	51.4	125	125	55.2	51.4	125	125
	R-70	200	260	120	27.9	39.4	125	125	55.2	39.4	125	125

¹⁾ Design according to EN 1992-4:2018 (for static resp. quasi-static loads). The partial safety factors for material resistance as regulated in the ETA as well as a partial safety factor for load actions of $\gamma_L = 1.4$ are considered. As a single anchor counts e.g. an anchor with a spacing $s \geq 3 \times h_{ef}$ and an edge distance $c \geq 1.5 \times h_{ef}$. Accurate data see ETA.

²⁾ The specified loads are valid for anchorages in dry and damp concrete. For temperatures in the anchoring substrate up to 50 °C (resp. short term up to 80 °C). Drill hole cleaning as per specification in the ETA. The factor Ψ_{sus} for sustained load was taken into account with 1.0.

³⁾ Further steel grades, versions and technical data see ETA, e.g. for dry internal conditions, galvanised steel (gvz); for damp interiors and for outdoor use, stainless steel (R).

⁴⁾ In the case of combinations of tension and shear loads, bending moments with reduced or minimum spacing and edge distances (anchor groups), the design must be carried out in accordance with the provisions of the complete ETA and the provisions of the EN 1992-4:2018. We recommend using our anchor design software C-FIX.

Epoxy mortar FIS EM Plus

The powerful injection mortar for rebar connections and cracked concrete



Rail fastenings



Rebar connections

3

Applications

- Post-installed rebar connections
- Jointers for concrete layers
- Rim beam anchorings
- Seismic applications
- Anchorings in diamond-drilled or in waterfilled drill holes
- Heavy steel constructions
- Silo installations
- Tall shelving
- Sound barriers
- Temporary or removable fixings (with internal threaded anchor RG M I)

Advantages

- The ETA assessment guarantees a service life of 100 years. The expert report of IEA Stuttgart even confirms a working life up to 120 years and thus underlines the reliability and durability of the FIS EM Plus.
- The optimised formulation of the epoxy resin mortar FIS EM Plus leads to improved load values in cracked and non-cracked concrete.
- The mortar can be used for rebar connections from diameter 8 to 40, including

- seismic applications.
- With the threaded rod FIS A, the loads to be applied can be designed variably by selecting the anchorage depth. The mortar is approved for diamond drilled and water-filled drillholes as well as seismic applications and thus offers safety under extreme conditions.
- For practical use on the building site, FIS EM Plus can be processed at low temperatures down to -5 °C.

Certificates



ETA-17/0979, for cracked concrete
ETA-17/1056, Post-installed rebar connections



Fire resistance classification R240



Building materials

- Approved for anchorings in:
- Concrete C20/25 to C50/60, cracked and non-cracked
- Also suitable for:
- Natural stone with dense structure

Functioning

- The epoxy mortar FIS EM Plus combined with the FIS A threaded rod, is suitable for pre-positioned and push-through installation.
- Resin and hardener are stored in two separate chambers and are not mixed and activated until extrusion through the injection capsule in the static mixer.
- The mortar is injected bubble-free from the drill hole base.
- The mortar bonds the entire surface of the anchor with the drill hole wall and seals off the drill hole.
- The anchor is set manually by lightly rotating it until it reaches the drill hole base.
- During push-through installation, the annular gap between the threaded rod and attachment is filled with FIS EM Plus.

For use with

Anchors & sleeves page 126



Dispenser page 189



Accessories page 194



Installation in concrete with FIS EM Plus and FIS A / RG M

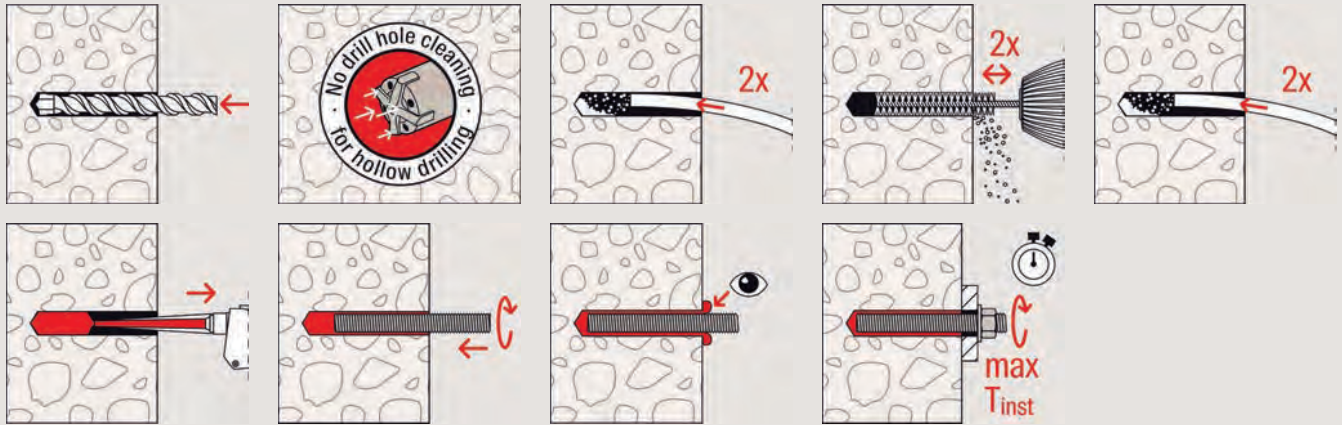

3

Installation in concrete with FIS EM Plus and RG M I

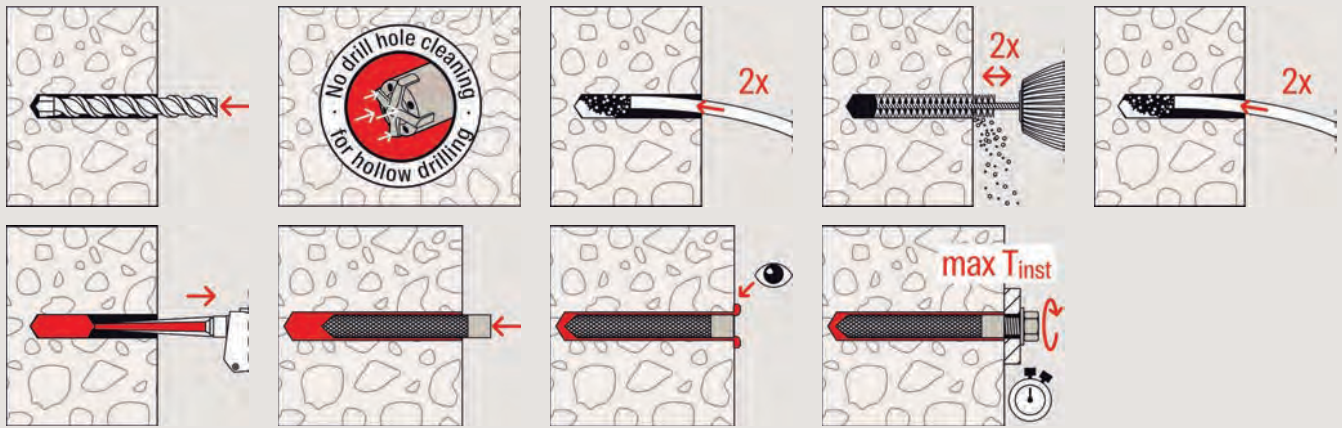

Technical data

Epoxy mortar FIS EM Plus



FIS EM Plus 390 S

FIS EM Plus 585 S

FIS EM Plus 1500 S

Item	Item No.	Approval		Languages on the cartridge	Scale unit	Contents	Sales unit [pcs]
		ETA	ICC				
FIS EM Plus 390 S	544154 ¹⁾	●	●	DE, EN, FR, NL, ES, PT	180	1 cartridge 390 ml, 2 x FIS MR Plus	6
FIS EM Plus 390 S	544155 ¹⁾	●	●	EN, ZH, EL, KO, HU, PL	180	1 cartridge 390 ml, 2 x FIS MR Plus	6
FIS EM Plus 390 S	544176 ¹⁾	●	●	CS, SK, RO, AR, FR, EN	180	1 cartridge 390 ml, 2 x FIS MR Plus	6
FIS EM Plus 390 S	544159 ¹⁾	●	●	LT, LV, ET, UK, RU, KK	180	1 cartridge 390 ml, 2 x FIS MR Plus	6
FIS EM Plus 585 S	544166 ¹⁾	●	●	DE, EN, FR, NL, ES, PT	270	1 cartridge 585 ml + 2 x FIS UMR	6
FIS EM Plus 585 S	544165 ¹⁾	●	●	EN, ZH, RU, KO, CS, PL	270	1 cartridge 585 ml + 2 x FIS UMR	6
FIS EM Plus 585 S	544175 ¹⁾	●	●	EN, ZH, RU, KO, CS, PL	270	1 cartridge 585 ml, 1 x FIS UMR, 1 x extension tube Ø 9x250 mm	6
FIS EM Plus 1500 S	544167 ¹⁾	●	●	DE, IT, FR, NL, CS, SK	700	1 cartridge 1500 ml, 2 x FIS UMR	4
FIS EM Plus 1500 S	544173 ¹⁾	●	●	EN, ES, PT, ZH, RU, PL	700	1 cartridge 1500 ml, 2 x FIS UMR	4

¹⁾ Dangerous goods - no express shipping possible.

Technical data

Static mixer



FIS MR Plus

FIS UMR

Item	Item No.	Contents	Sales unit [pcs]
FIS MR Plus	545853	10 static mixer FIS MR Plus	10
FIS UMR	520593	10 static mixer for 585 ml and 1500 ml cartridges	10

Technical data

Epoxy mortar FIS EM Plus



FIS EM Plus 390 S HWK big

FIS EM Plus 390 S in bucket

Item	Item No.	Approval		Languages on the cartridge	Contents	Sales unit [pcs]
		ETA	ICC			
FIS EM Plus 390 S in bucket	544172 ¹⁾	●	●	DE, EN, FR, NL, ES, PT	20 cartridges 390 ml, 20 x FIS MR Plus	1
FIS EM Plus 390 S HWK big	544156 ¹⁾	●	●	EN, ZH, EL, KO, HU, PL	20 cartridges 390 ml, 20 x FIS MR Plus	1

¹⁾ Dangerous goods - no express shipping possible.

Curing times

FIS EM Plus Temperature in anchoring base [°C]	Maximum processing time t_{work} [min.]	Minimum curing time ¹⁾ t_{cure} [hrs.]
-5 - 0	240	200
> 0 - +5	150	90
> +5 - +10	120	40
> -10 - +20	30	18
> +20 - +30	14	10
> +30 - +40	7	5

¹⁾ In wet concrete or water filled holes the curing times must be doubled.

Loads

Injection system FIS EM Plus with internal threaded anchor RG M I

Permissible loads of a single anchor^{1) 2)} in normal concrete of strength class C20/25.
For the design the complete current assessment ETA-17/0979 has to be considered.

Type	Screw material ³⁾	Effective anchorage depth h_{ef} [mm]	Minimum member thickness h_{min} [mm]	Maximum installation-torque $T_{inst,max}$ [Nm]	Cracked concrete				Non-cracked concrete			
					Permissible tension (N_{perm}) and shear loads (V_{perm}); minimum spacing (s_{min}) and edge distances (c_{min}) with reduced loads				Permissible tension (N_{perm}) and shear loads (V_{perm}); minimum spacing (s_{min}) and edge distances (c_{min}) with reduced loads			
					$N_{perm}^{4)}$ [kN]	$V_{perm}^{4)}$ [kN]	$s_{min}^{4)}$ [mm]	$c_{min}^{4)}$ [mm]	$N_{perm}^{4)}$ [kN]	$V_{perm}^{4)}$ [kN]	$s_{min}^{4)}$ [mm]	$c_{min}^{4)}$ [mm]
RG M8 I	5.8	90	120	10	9.0	5.3	55	55	9.0	5.3	55	55
	8.8	90	120	10	11.3	8.3	55	55	13.8	8.3	55	55
	R-70	90	120	10	9.9	5.9	55	55	9.9	5.9	55	55
RG M10 I	5.8	90	130	20	12.9	8.3	65	65	13.8	8.3	65	65
	8.8	90	130	20	12.9	13.3	65	65	20.0	13.3	65	65
	R-70	90	130	20	12.9	9.3	65	65	15.7	9.3	65	65
RG M12 I	5.8	125	170	40	20.2	12.1	75	75	20.5	12.1	75	75
	8.8	125	170	40	20.2	19.3	75	75	32.4	19.3	75	75
	R-70	125	170	40	20.2	13.5	75	75	22.5	13.5	75	75
RG M16 I	5.8	160	210	80	33.2	22.4	95	95	37.6	22.4	95	95
	8.8	160	210	80	33.2	30.9	95	95	47.4	30.9	95	95
	R-70	160	210	80	33.2	25.1	95	95	42.0	25.1	95	95
RG M20 I	5.8	200	260	120	46.4	35.4	125	125	58.6	35.4	125	125
	8.8	200	260	120	46.4	51.4	125	125	66.3	51.4	125	125
	R-70	200	260	120	46.4	39.4	125	125	66.7	39.4	125	125

¹⁾ Design according to EN 1992-4:2018 (for static resp. quasi-static loads). The partial safety factors for material resistance as regulated in the ETA as well as a partial safety factor for load actions of $\gamma_L = 1.4$ are considered. As a single anchor counts e.g. an anchor with a spacing $s \geq 3 \times h_{ef}$ and an edge distance $c \geq 1.5 \times h_{ef}$. Accurate data see ETA.

²⁾ The specified loads are valid for anchorages in dry and damp concrete. For temperatures in the anchoring substrate up to 50 °C (resp. short term up to 72 °C). Drill hole cleaning as per specification in the ETA. The factor Ψ_{SUS} for sustained load was taken into account with 1.0.

³⁾ Further steel grades, versions and technical data see ETA, e.g. for dry internal conditions, galvanised steel (gvz); for damp interiors and for outdoor use, stainless steel (R).

⁴⁾ In the case of combinations of tension and shear loads, bending moments with reduced or minimum spacing and edge distances (anchor groups), the design must be carried out in accordance with the provisions of the complete ETA and the provisions of the EN 1992-4:2018. We recommend using our anchor design software C-FIX.

Loads

Injection system FIS EM Plus with threaded rod FIS A resp. RG M

Permissible loads of a single anchor^{1) 2)} in normal concrete of strength class C20/25.
For the design the complete current assessment ETA-17/0979 has to be considered.

Type	Material/ surface ³⁾	Effective anchorage depth h_{ef} [mm]	Minimum member thickness h_{min} [mm]	Maximum installation- torque $T_{inst,max}$ [Nm]	Cracked concrete				Non-cracked concrete			
					Permissible tension (N_{perm}) and shear loads (V_{perm}); minimum spacing (s_{min}) and edge distances (c_{min}) with reduced loads				Permissible tension (N_{perm}) and shear loads (V_{perm}); minimum spacing (s_{min}) and edge distances (c_{min}) with reduced loads			
					$N_{perm}^{4)}$ [kN]	$V_{perm}^{4)}$ [kN]	$s_{min}^{4)}$ [mm]	$c_{min}^{4)}$ [mm]	$N_{perm}^{4)}$ [kN]	$V_{perm}^{4)}$ [kN]	$s_{min}^{4)}$ [mm]	$c_{min}^{4)}$ [mm]
FIS A M 8	5.8	60	100	10	5.4	6.3	40	40	9.0	6.3	40	40
	5.8	80	110	10	7.2	6.3	40	40	9.0	6.3	40	40
	5.8	160	190	10	9.0	6.3	40	40	9.0	6.3	40	40
	R-70	60	100	10	5.4	6.0	40	40	9.9	6.0	40	40
	R-70	80	110	10	7.2	6.0	40	40	9.9	6.0	40	40
	R-70	160	190	10	9.9	6.0	40	40	9.9	6.0	40	40
FIS A M 10	5.8	60	100	20	6.7	9.7	45	45	10.9	9.7	45	45
	5.8	90	120	20	10.1	9.7	45	45	13.8	9.7	45	45
	5.8	200	230	20	13.8	9.7	45	45	13.8	9.7	45	45
	R-70	60	100	20	6.7	9.2	45	45	10.9	9.2	45	45
	R-70	90	120	20	10.1	9.2	45	45	15.7	9.2	45	45
	R-70	200	230	20	15.7	9.2	45	45	15.7	9.2	45	45
FIS A M 12	5.8	70	100	40	9.6	14.3	55	45	13.7	14.3	55	45
	5.8	110	140	40	17.8	14.3	55	45	20.5	14.3	55	45
	5.8	240	270	40	20.5	14.3	55	45	20.5	14.3	55	45
	R-70	70	100	40	9.6	13.7	55	45	13.7	13.7	55	45
	R-70	110	140	40	17.8	13.7	55	45	22.5	13.7	55	45
	R-70	240	270	40	22.5	13.7	55	45	22.5	13.7	55	45
FIS A M 16	5.8	80	120	60	11.7	23.5	65	50	16.8	26.9	65	50
	5.8	125	170	60	22.9	26.9	65	50	32.7	26.9	65	50
	5.8	320	360	60	37.6	26.9	65	50	37.6	26.9	65	50
	R-70	80	120	60	11.7	23.5	65	50	16.8	25.2	65	50
	R-70	125	170	60	22.9	25.2	65	50	32.7	25.2	65	50
	R-70	320	360	60	42.0	25.2	65	50	42.0	25.2	65	50
FIS A M 20	5.8	90	140	120	14.0	28.0	85	55	20.0	40.0	85	55
	5.8	170	220	120	36.3	42.3	85	55	51.9	42.3	85	55
	5.8	400	450	120	58.6	42.3	85	55	58.6	42.3	85	55
	R-70	90	140	120	14.0	28.0	85	55	20.0	39.4	85	55
	R-70	170	220	120	36.3	39.4	85	55	51.9	39.4	85	55
	R-70	400	450	120	65.7	39.4	85	55	65.7	39.4	85	55
FIS A M 24	5.8	96	160	150	15.4	30.8	105	60	22.0	44.1	105	60
	5.8	210	270	150	49.9	60.6	105	60	71.3	60.6	105	60
	5.8	480	540	150	84.3	60.6	105	60	84.3	60.6	105	60
	R-70	96	160	150	15.4	30.8	105	60	22.0	44.1	105	60
	R-70	210	270	150	49.9	56.8	105	60	71.3	56.8	105	60
	R-70	480	540	150	94.3	56.8	105	60	97.3	56.8	105	60
FIS A M 30	5.8	120	190	300	21.6	43.1	140	80	30.8	61.6	140	80
	5.8	280	350	300	76.8	96.0	140	80	109.8	96.0	140	80
	5.8	600	670	300	133.8	96.0	140	80	133.8	96.0	140	80
	R-70	120	190	300	21.6	43.1	140	80	30.8	61.6	140	80
	R-70	280	350	300	76.8	90.2	140	80	109.8	90.2	140	80
	R-70	600	670	300	150.1	90.2	140	80	150.1	90.2	140	80

¹⁾ Design according to EN 1992-4:2018 (for static resp. quasi-static loads). The partial safety factors for material resistance as regulated in the ETA as well as a partial safety factor for load actions of $\gamma_L = 1.4$ are considered. As a single anchor counts e.g. an anchor with a spacing $s \geq 3 \times h_{ef}$ and an edge distance $c \geq 1.5 \times h_{ef}$. Accurate data see ETA.

²⁾ The specified loads are valid for anchorages in dry and damp concrete. For temperatures in the anchoring substrate up to 50 °C (resp. short term up to 72 °C). Drill hole cleaning as per specification in the ETA. The factor ψ_{sus} for sustained load was taken into account with 1.0.

³⁾ Further steel grades, versions and technical data see ETA, e.g. for dry internal conditions, galvanised steel (gvz); for damp interiors and for outdoor use, stainless steel (R).

⁴⁾ In the case of combinations of tension and shear loads, bending moments with reduced or minimum spacing and edge distances (anchor groups), the design must be carried out in accordance with the provisions of the complete ETA and the provisions of the EN 1992-4:2018. We recommend using our anchor design software C-FIX.

Epoxy mortar FIS EB

The basic epoxy mortar for applications in concrete

3



Crash barriers and sound insulation walls

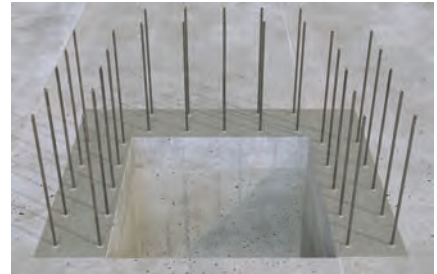

Post-installed rebar connections

Applications

- Heavy steel constructions
- Consoles
- Silo installations
- Tall shelving
- Post-installed rebar connections

Advantages

- FIS EB is approved for post-installed rebar connections according to ETA and for use in cracked concrete according to ETA and ICC.
- The injection mortar achieves a reliable performance in many applications which

enables economical use.

- FIS EB can be used under various installation conditions and is approved for seismic applications, making it a safe system.
- Variable anchorage depths allow ideal adaptation to the load to be transmitted.

Certificates



ETA-15/0440, for cracked concrete
ETA-15/0771, for post-installed rebar connection



See ICC-ES Evaluation Report at www.icc-es.org



Fire resistance classification R240



Building materials

Approved for anchorings in:

- Concrete C20/20 to C50/60, cracked and noncracked

Functioning

- The epoxy mortar FIS EB combined with the threaded rod FIS A is suitable for pre-positioned and push-through installation.
- Resin and hardener are stored in two separate chambers and are not mixed and activated until extrusion through the injection capsule in the static mixer.
- The mortar is injected bubble-free from the drill hole base.
- The mortar bonds the entire surface of the threaded rod with the drill hole wall and seals off the drill hole.
- The threaded rod is set manually by slightly rotating it until it reached the drill hole base.
- During push-through installation, the annular gap between the threaded rod and the attachment is filled with FIS EB.

For use with

Anchors & sleeves page 126



Dispenser page 189



Accessories page 194



Installation in concrete with FIS EB and FIS A / RG M

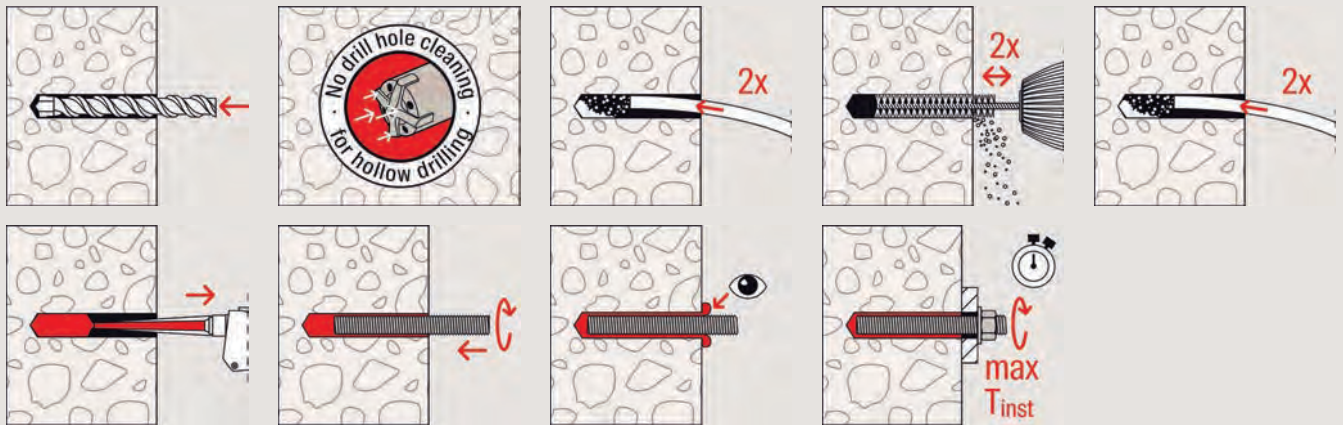

3

Technical data

Epoxy mortar FIS EB



FIS EB

FIS MR Plus

Item	Item No.	Approval ETA	Languages on the cartridge	Scale unit	Contents	Sales unit [pcs]
FIS EB 390 S	534984 ¹⁾	●	EN, ES, PT	180	1 cartridge 390 ml, 2 x FIS MR Plus	6
FIS EB 390 S	534985 ¹⁾	●	TR, RU, KO	180	1 cartridge 390 ml, 2 x FIS MR Plus	6
FIS EB 390 S in bucket	543652 ¹⁾	●	EN, ES, PT	180	20 cartridges 390 ml, 20 x FIS MR Plus	1
FIS EB 390 S in bucket	538547 ¹⁾	●	TR, RU, KO	180	20 cartridges 390 ml, 20 x FIS MR Plus	1
FIS EB 585 S	534986 ¹⁾	●	EN, ES, PT, IT	270	1 cartridge 585 ml + 2 x FIS UMR	6
FIS MR Plus	545853	—	—	—	10 static mixer FIS MR Plus	10

1) Dangerous goods - no express shipping possible.

Curing times

FIS EB Temperatures at anchoring base [°C]	Maximum processing time t_{work} [min.]	Minimum curing time ¹⁾ t_{cure} [hrs.]
+5 – +10	120	45
> +10 – +20	30	22
> +20 – +30	14	12
> +30 – +40	7	6

1) In wet concrete or flooded holes the curing time must be doubled.

Loads

Injection system FIS EB with anchor rod FIS A resp. RG M

Permissible loads of a single anchor^{1,2)} in normal concrete of strength class C20/25.
For the design the complete current assessment ETA-15/0440 has to be considered.

Type	Material / surface ³⁾	Effective anchorage depth h_{ef} [mm]	Minimum member thickness h_{min} [mm]	Maximum installation torque $T_{inst,max}$ [Nm]	Cracked concrete				Non-cracked concrete			
					Permissible tension (N_{perm}) and shear loads (V_{perm}); minimum spacing (s_{min}) and edge distances (c_{min}) with reduced loads				Permissible tension (N_{perm}) and shear loads (V_{perm}); minimum spacing (s_{min}) and edge distances (c_{min}) with reduced loads			
					$N_{perm}^{4)}$ [kN]	$V_{perm}^{4)}$ [kN]	$s_{min}^{4)}$ [mm]	$c_{min}^{4)}$ [mm]	$N_{perm}^{4)}$ [kN]	$V_{perm}^{4)}$ [kN]	$s_{min}^{4)}$ [mm]	$c_{min}^{4)}$ [mm]
FIS A M 8	5.8	60	100	10	3.6	5.1	40	40	7.9	5.1	40	40
	5.8	80	110	10	4.8	5.1	40	40	9.0	5.1	40	40
	5.8	160	190	10	9.0	5.1	40	40	9.0	5.1	40	40
	R-70	60	100	10	3.6	6.0	40	40	7.9	6.0	40	40
	R-70	80	110	10	4.8	6.0	40	40	9.9	6.0	40	40
	R-70	160	190	10	9.6	6.0	40	40	9.9	6.0	40	40
FIS A M 10	5.8	60	100	20	4.5	8.6	45	45	9.0	8.6	45	45
	5.8	90	120	20	6.7	8.6	45	45	13.5	8.6	45	45
	5.8	200	230	20	13.8	8.6	45	45	13.8	8.6	45	45
	R-70	60	100	20	4.5	9.0	45	45	9.0	9.2	45	45
	R-70	90	120	20	6.7	9.2	45	45	13.5	9.2	45	45
	R-70	200	230	20	15.0	9.2	45	45	15.7	9.2	45	45
FIS A M 12	5.8	70	100	40	6.3	12.0	55	55	12.6	12.0	55	55
	5.8	110	140	40	9.9	12.0	55	55	19.7	12.0	55	55
	5.8	240	270	40	20.5	12.0	55	55	20.5	12.0	55	55
	R-70	70	100	40	6.3	12.6	55	55	12.6	13.7	55	55
	R-70	110	140	40	9.9	13.7	55	55	19.7	13.7	55	55
	R-70	240	270	40	21.5	13.7	55	55	22.5	13.7	55	55
FIS A M 16	5.8	80	120	60	7.7	15.3	65	65	16.8	22.3	65	65
	5.8	125	170	60	12.0	22.3	65	65	27.0	22.3	65	65
	5.8	320	360	60	30.6	22.3	65	65	37.6	22.3	65	65
	R-70	80	120	60	7.7	15.3	65	65	16.8	25.2	65	65
	R-70	125	170	60	12.0	23.9	65	65	26.9	25.2	65	65
	R-70	320	360	60	30.6	25.2	65	65	42.0	25.2	65	65
FIS A M 20	5.8	90	140	120	10.8	21.5	85	85	20.0	34.9	85	85
	5.8	170	220	120	20.3	34.9	85	85	40.7	34.9	85	85
	5.8	400	450	120	47.9	34.9	85	85	58.6	34.9	85	85
	R-70	90	140	120	10.8	21.5	85	85	20.0	39.4	85	85
	R-70	170	220	120	20.3	39.4	85	85	40.7	39.4	85	85
	R-70	400	450	120	47.9	39.4	85	85	65.7	39.4	85	85
FIS A M 24	5.8	96	160	150	12.9	30.8	105	105	18.4	44.1	105	105
	5.8	210	270	150	31.4	50.9	105	105	50.3	50.9	105	105
	5.8	480	540	150	71.8	50.9	105	105	84.3	50.9	105	105
	R-70	96	160	150	12.9	30.8	105	105	18.4	44.1	105	105
	R-70	210	270	150	31.4	56.8	105	105	50.3	56.8	105	105
	R-70	480	540	150	71.8	56.8	105	105	94.3	56.8	105	105
FIS A M 30	5.8	120	190	300	18.0	43.1	140	140	25.7	61.6	140	140
	5.8	280	350	300	52.4	80.6	140	140	78.5	80.6	140	140
	5.8	600	670	300	112.2	80.6	140	140	133.8	80.6	140	140
	R-70	120	190	300	18.0	43.1	140	140	25.7	61.6	140	140
	R-70	280	350	300	52.4	90.2	140	140	78.5	90.2	140	140
	R-70	600	670	300	112.2	90.2	140	140	150.1	90.2	140	140

¹⁾ Design according to EN 1992-4:2018 (for static resp. quasi-static loads). The partial safety factors for material resistance as regulated in the ETA as well as a partial safety factor for load actions of $\gamma_L = 1.4$ are considered. As a single anchor counts e.g. an anchor with a spacing $s \geq 3 \times h_{ef}$ and an edge distance $c \geq 1.5 \times h_{ef}$. Accurate data see ETA.

²⁾ The specified loads are valid for anchorages in dry and damp concrete. For temperatures in the anchoring substrate up to 50 °C (resp. short term up to 80 °C). Drill hole cleaning as per specification in the ETA. The factor Ψ_{sus} for sustained load was taken into account with 1.0.

³⁾ Further steel grades, versions and technical data see ETA, e.g. for dry internal conditions, galvanised steel (guz); for damp interiors and for outdoor use, stainless steel (R).

⁴⁾ In the case of combinations of tension and shear loads, bending moments with reduced or minimum spacing and edge distances (anchor groups), the design must be carried out in accordance with the provisions of the complete ETA and the provisions of the EN 1992-4:2018. We recommend using our anchor design software C-FIX.

Epoxy mortar FIS EP

The cost-efficient epoxy mortar for applications in concrete



Column bases



Steel girders

3

Applications

- Columns
- Beams
- Shear dowels
- Starter bars
- Polders

Advantages

- FIS EP is the economical epoxy resin mortar for applications in concrete that do not require approval.
- The epoxy mortar FIS EP can also be used in cracked concrete for construction site convenient installation.
- With the anchor rod FIS A, the loads to be

introduced can be selected variably by choosing the anchorage depth.

- FIS EP can be used for smooth installation with the standard fischer accessories.

Building materials

Suitable for:

- Concrete C20/25 to C50/60, non-cracked and cracked

Functioning

- The epoxy mortar FIS EP combined with the FIS A threaded rod is suitable for pre-positioned and push-through installation.
- Resin and hardener are stored in two separate chambers, thus are not mixed and activated until extrusion through the static mixer.
- The mortar bonds the entire surface of the anchor with the drill hole wall and seals off the drill hole.
- The anchor is set manually by slightly rotating it until the anchor reaches the drill hole base.
- During push-through installation, the annular gap is filled with FIS EP.

For use with

Anchors & sleeves page

126



Dispenser page 189



Accessories page

194



Installation in concrete with FIS EP and FIS A

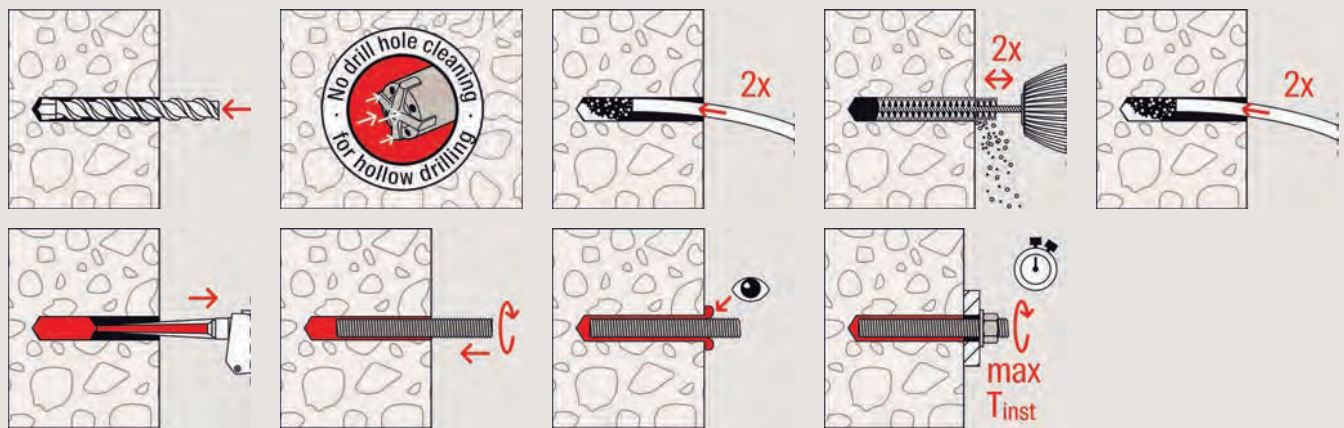

3

Technical data

Epoxy mortar FIS EP



FIS EP 390 S

FIS EP 585 S

FIS MR Plus

Item	Item No.	Languages on the cartridge	Scale unit	Contents	Sales unit [pcs]
FIS EP 390 S	553526	AR, EN, ES, PT	180	1 cartridge 390 ml, 1 x FIS MR Plus	20
FIS EP 585 S	553514	PT, ES, EN	270	1 cartridge 585 ml, 1 x FIS MR Plus	14
FIS MR Plus	545853	—	—	10 static mixer FIS MR Plus	10

Curing times

FIS EP Temperature at anchoring base [°C]	Maximum processing time t_{work} [min.]	Minimum curing time ¹⁾ t_{cure} [hrs.]
+5 – +10	180	96
>+10 – +15	90	48
>+15 – +20	60	36
>+20 – +30	30	24
>+30 – +40	15	12

1) In wet concrete or water filled holes the curing times must be doubled.

Loads

Injection system FIS EP with threaded rod FIS A resp. RGM

Recommended loads of a single anchor¹⁾²⁾ in normal concrete of strength class C20/25.

Type	Material / surface ³⁾	Effective anchorage depth h_{ef} [mm]	Minimum member thickness h_{min} [mm]	Maximum installation torque $T_{inst,max}$ [Nm]	Cracked concrete				Non-cracked concrete			
					Recommended tension- (N_{rec}) and shear loads (V_{rec}); minimum spacing (s_{min}) and edge distances (c_{min}) with reduced loads				Recommended tension- (N_{rec}) and shear loads (V_{rec}); minimum spacing (s_{min}) and edge distances (c_{min}) with reduced loads			
					$N_{rec}^{4)}$ [kN]	$V_{rec}^{4)}$ [kN]	$s_{min}^{4)}$ [mm]	$c_{min}^{4)}$ [mm]	$N_{rec}^{4)}$ [kN]	$V_{rec}^{4)}$ [kN]	$s_{min}^{4)}$ [mm]	$c_{min}^{4)}$ [mm]
FIS A M 8	5.8	60	100	10	-	-	-	-	5.4	5.1	40	40
	5.8	160	190	10	-	-	-	-	9.0	5.1	40	40
	R-70	60	100	10	-	-	-	-	5.4	6.0	40	40
	R-70	160	190	10	-	-	-	-	9.9	6.0	40	40
FIS A M 10	5.8	60	100	20	-	-	-	-	6.4	8.6	45	45
	5.8	200	230	20	-	-	-	-	13.8	8.6	45	45
	R-70	60	100	20	-	-	-	-	6.4	9.2	45	45
	R-70	200	230	20	-	-	-	-	15.7	9.2	45	45
FIS A M 12	5.8	70	100	40	4.2	10.1	55	55	8.4	12.0	55	55
	5.8	240	270	40	14.4	12.0	55	55	20.5	12.0	55	55
	R-70	70	100	40	4.2	10.1	55	55	8.4	13.7	55	55
	R-70	240	270	40	14.4	13.7	55	55	22.5	13.7	55	55
FIS A M 16	5.8	80	120	60	6.4	15.3	65	65	12.0	22.3	65	65
	5.8	320	360	60	25.5	22.3	65	65	37.6	22.3	65	65
	R-70	80	120	60	6.4	15.3	65	65	12.0	25.2	65	65
	R-70	320	360	60	25.5	25.2	65	65	42.0	25.2	65	65
FIS A M 20	5.8	90	140	120	9.0	21.5	85	85	15.7	34.9	85	85
	5.8	400	450	120	39.9	34.9	85	85	58.6	34.9	85	85
	R-70	90	140	120	9.0	21.5	85	85	15.7	37.7	85	85
	R-70	400	450	120	39.9	39.4	85	85	65.7	39.4	85	85
FIS A M 24	5.8	96	160	150	-	-	-	-	17.2	41.4	105	105
	5.8	480	540	150	-	-	-	-	84.3	50.9	105	105
	R-70	96	160	150	-	-	-	-	17.2	41.4	105	105
	R-70	480	540	150	-	-	-	-	86.2	56.8	105	105
FIS A M 30	5.8	120	190	300	-	-	-	-	24.7	59.2	140	140
	5.8	600	670	300	-	-	-	-	123.4	80.6	140	140
	R-70	120	190	300	-	-	-	-	24.7	59.2	140	140
	R-70	600	670	300	-	-	-	-	123.4	90.2	140	140

¹⁾ Design according to EN 1992-4:2018 (for static resp. quasi-static loads). The partial safety factors for material resistance and a partial safety factor for load actions of $\gamma_L = 1.4$ are considered. As an single anchor counts e.g. an anchor with a spacing $s \geq 3 \times h_{ef}$ and an edge distance $c \geq 1.5 \times h_{ef}$.

²⁾ The specified loads are valid for anchorages in dry and damp concrete. For temperatures in the anchoring substrate up to 43 °C (resp. short term up to 55 °C). Drill hole cleaning according to installation instructions. The factor Ψ_{sus} for sustained load was taken into account with 1.0.

³⁾ For dry internal conditions, galvanised steel (gvz); for damp interiors and for outdoor use, stainless steel (R). Further steel grades by request.

⁴⁾ In the case of combinations of tension and shear loads, bending moments with reduced or minimum spacing and edge distances (anchor groups), the design must be carried out in accordance the provisions of the EN 1992-4:2018.

Injection mortar FIS V Plus

The powerful universal mortar for concrete and masonry

3

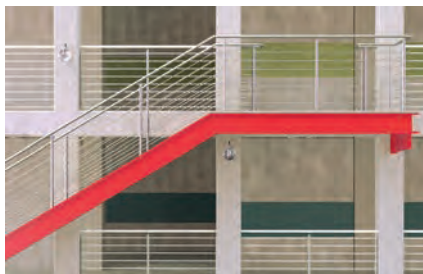

Steel constructions



Rescue ladders

Applications

Injection mortar for use with:

- Threaded rods FIS A, see page 128
- Internal threaded anchor RG MI, see page 142
- Rebar anchor FRA, see page 170
- Concrete steel bars, see page 177
- Injection anchor sleeves FIS H, see page 149
- Aerated concrete centring sleeve PBZ, see page 194
- Remedial wall tie VBS 8, see page 179
- Weather facing reconstruction system FWS II, see page 181

Advantages

- The FIS V Plus injection mortar has numerous system approvals, such as in cracked and non-cracked concrete, masonry and for special applications.
- The ETA assessment for a service life of 100 years offers permanent safety for all applications.
- The approved use in water-filled drill holes enables a wide range of applications, even under harsh environmental conditions.
- FIS VW Plus High Speed has a significantly shorter curing time than FIS V Plus, thus also ensuring swift work progress even at low temperatures.
- Due to the possible installation temperature of -10° to 40°C the universal mortar can be applied all year long.
- FIS VS Plus Low Speed with extended gelling time prevents premature curing of the mortar at higher temperatures and is ideally suited to large drill hole depths.
- The extensive range of accessories is ideally suited to the FIS V Plus injection mortar family, increases the great flexibility of the system and thus allows for a broad range of applications.

Certificates



ETA-20/0603, for concrete

ETA-20/0728, for post-installed rebar connections

ETA-20/0729, for masonry



Fire resistance classification R120



Building materials

Approved for anchorings in:

- Concrete C20/25 to C50/60, cracked and non-cracked
- Hollow blocks made from lightweight concrete
- Hollow blocks made from concrete
- Vertically perforated brick
- Perforated sand-lime brick
- Solid sand-lime brick
- Aerated concrete
- Solid brick

Approved for:

- Rebar connections
- Remedial wall tie VBS 8
- Weather facing reconstruction system FWS II
- Stand-off installation TherMax

Functioning

- The FIS V Plus is a 2-component injection mortar based on vinyl ester hybrid.
- Resin and hardener are stored in two separate chambers and are not mixed and activated until extrusion through the static mixer.
- The injection cartridges are quick and easy to use with the fischer dispensers.
- Partially used cartridges can be reused, simply by changing the static mixer.

For use with

Anchors & sleeves page 126



Dispenser page 189



Accessories page 194



Installation in concrete with FIS V Plus and FIS A / RG M

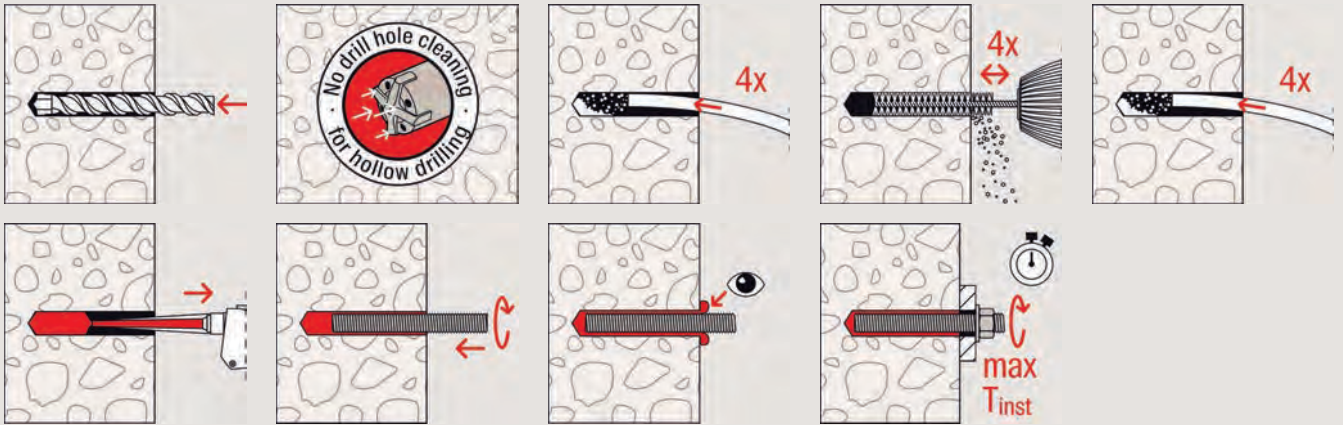

Installation in concrete with FIS V Plus and RG M I

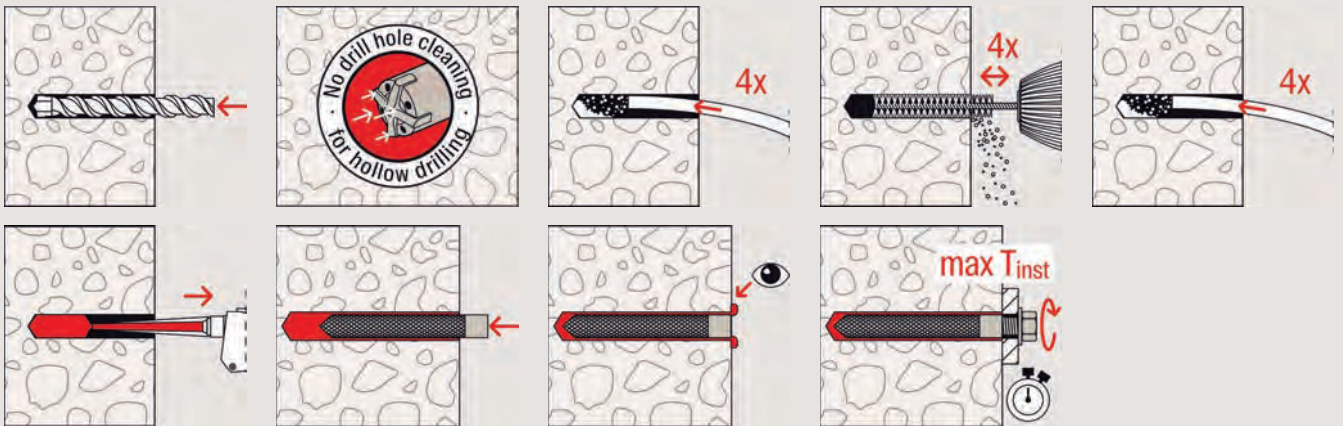

Installation in solid brick with FIS V Plus and FIS A

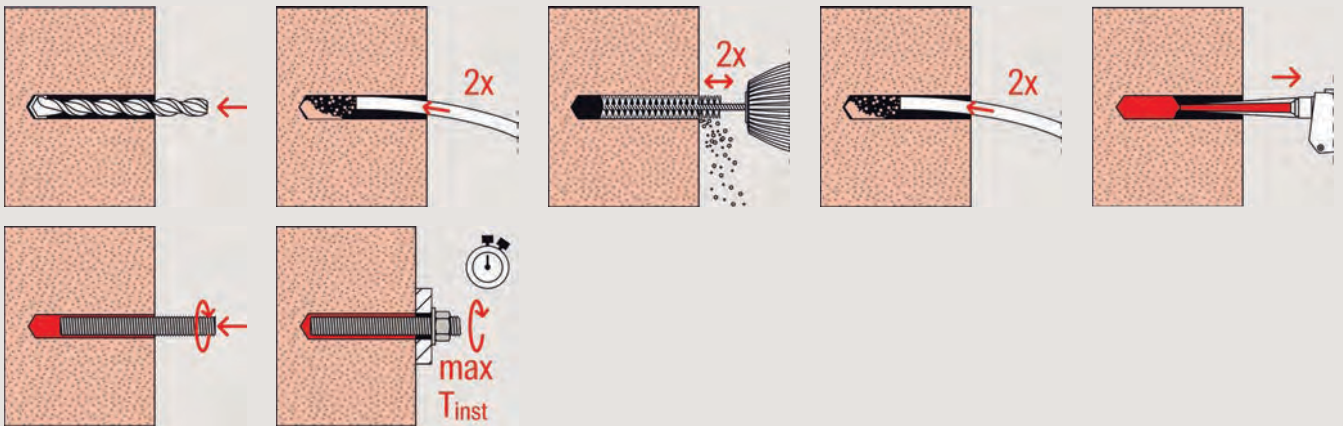

Installation in hollow blocks with FIS V Plus and FIS HK + FIS A

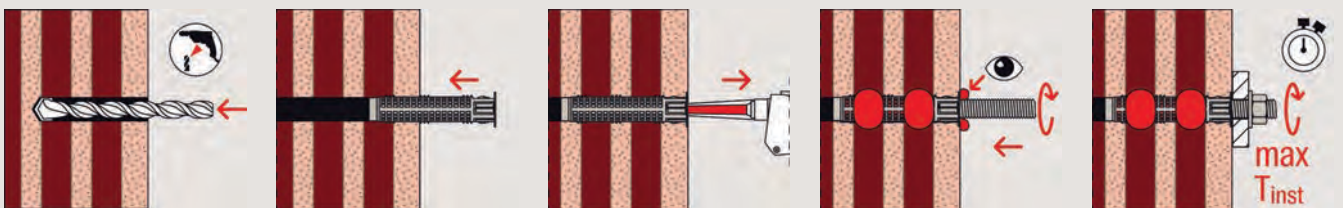

Installation in aerated concrete with FIS V Plus and FIS A / RG M

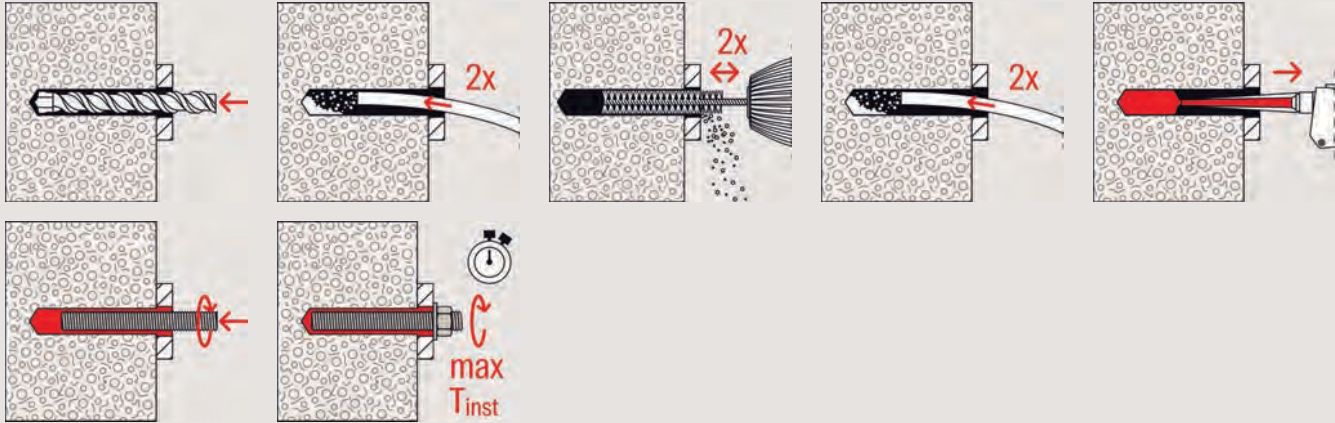

3

Installation in undercut drill hole in aerated concrete with FIS V Plus and FIS A / RG M

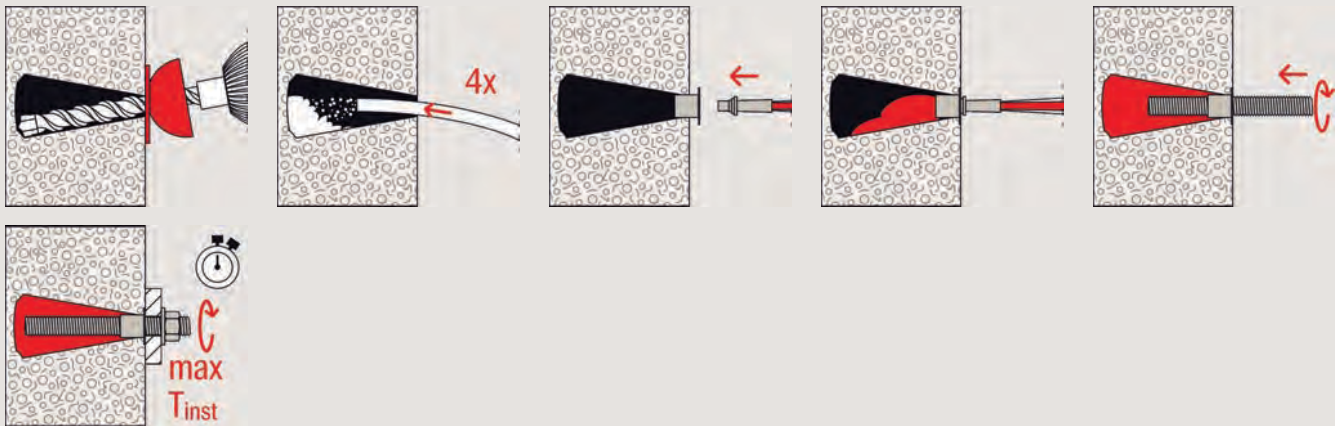

Technical data

Injection mortar FIS V Plus



FIS V Plus 360 S

Item	Item No.	Approval			Languages on the cartridge	Contents	Sales unit [pcs]
		DIBt	ETA	ICC			
FIS V Plus 360 S (IN)	558744	●	●	●	EN	1 cartridge 360 ml, 2 x FIS MR Plus	6
FIS V Plus 360 S (DE)	558745	●	●	●	DE	1 cartridge 360 ml, 2 x FIS MR Plus	6
FIS V Plus 360 S (EN,ES,PT)	558746	●	●	●	EN, ES, PT	1 cartridge 360 ml, 2 x FIS MR Plus	6
FIS V Plus 360 S (AR,ZH,EN)	558747	●	●	●	AR, ZH, EN	1 cartridge 360 ml, 2 x FIS MR Plus	6
FIS V Plus 360 S (DE,FR,NL)	558752	●	●	●	DE, FR, NL	1 cartridge 360 ml, 2 x FIS MR Plus	6
FIS V Plus 360 S (IT,PL,RO)	558753	●	●	●	IT, PL, RO	1 cartridge 360 ml, 2 x FIS MR Plus	6
FIS V Plus 360 S (TR,EL,AR)	558754	●	●	●	TR, EL, AR	1 cartridge 360 ml, 2 x FIS MR Plus	6
FIS V Plus 360 S (DK,NO,SE,FI)	558755	●	●	●	DK, NO, SE, FI	1 cartridge 360 ml, 2 x FIS MR Plus	6
FIS V Plus 360 S (EN,ES,PT)	558758	●	●	●	USA, RA, BR, MEX	1 cartridge 360 ml, 2 x FIS MR Plus	6
FIS V Plus 360 S (RU,UK,KK)	558760	●	●	●	RU, UK, KK	1 cartridge 360 ml, 2 x FIS MR Plus	6
FIS V Plus 360 S (CS,SK,HU)	558762	●	●	●	CS, SK, HU	1 cartridge 360 ml, 2 x FIS MR Plus	6
FIS V Plus 360 S (EN,FR,AR)	560635	●	●	●	EN, FR, AR	1 cartridge 360 ml, 2 x FIS MR Plus	6
FIS V Plus 360 S (PL,EN,RU)	561055	●	●	●	PL, EN, RU	1 cartridge 360 ml, 2 x FIS MR Plus	6

Technical data

Injection mortar FIS VS Plus



FIS VS Plus 360 S

Item	Item No.	Approval			Languages on the cartridge	Contents	Sales unit [pcs]
		DIBt	ETA	ICC			
FIS VS Plus 360 S (ZH,JA,KO)	558749	●	●	●	ZH, JA, KO	1 cartridge 360 ml, 2 x FIS MR Plus	6
FIS VS Plus 360 S (EN,ES,PT)	558750	●	●	●	EN, ES, PT	1 cartridge 360 ml, 2 x FIS MR Plus	6
FIS VS Plus 360 S (PL,EN,RU)	561057	●	●	●	PL, EN, RU	1 cartridge 360 ml, 2 x FIS MR Plus	6

Technical data

Injection mortar FIS VW Plus



FIS VW Plus 360 S

Item	Item No.	Approval			Languages on the cartridge	Contents	Sales unit [pcs]
		DIBt	ETA	ICC			
FIS VW Plus 360 S (DE)	558759	●	●	●	DE	1 cartridge 360 ml, 2 x FIS MR Plus	6
FIS VW Plus 360 S (EN,HU)	558764	●	●	●	EN, HU	1 cartridge 360 ml, 2 x FIS MR Plus	6
FIS VW Plus 360 S (DE,FR,NL)	558765	●	●	●	DE, FR, NL	1 cartridge 360 ml, 2 x FIS MR Plus	6
FIS VW Plus 360 S (RU,UK,KK)	558767	●	●	●	RU, UK, KK	1 cartridge 360 ml, 2 x FIS MR Plus	6
FIS VW Plus 360 S (PL,CS,RO)	558768	●	●	●	PL, CS, RO	1 cartridge 360 ml, 2 x FIS MR Plus	6
FIS VW Plus 360 S (PL,EN,RU)	562602	●	●	●	PL, EN, RU	1 cartridge 360 ml, 2 x FIS MR Plus	6

Technical data

Injection mortar FIS V Plus



FIS V Plus 360 S HWK K

Item	Item No.	Approval			Languages on the cartridge	Contents	Sales unit [pcs]
		DIBt	ETA	ICC			
FIS V Plus 360 S (DE) HWK K	558770	●	●	●	DE	10 cartridges 360 ml, 20 x FIS MR Plus	1
FIS V Plus 360 S (CS,SK,HU) HWK K	558771	●	●	●	CS, SK, HU	10 cartridges 360 ml, 20 x FIS MR Plus	1
FIS V Plus 360 S (DE,FR,NL) HWK K	558769	●	●	●	DE, FR, NL	10 cartridges 360 ml, 20 x FIS MR Plus	1

Technical data

Injection mortar FIS V Plus



FIS V Plus 360 S HWK G

Item	Item No.	Approval			Languages on the cartridge	Contents	Sales unit [pcs]
		DIBt	ETA	ICC			
FIS V Plus 360 S (DE) HWK G	558756	●	●	●	DE	20 cartridges 360 ml, 40 static mixer FIS MR Plus	1
FIS V Plus 360 S (AR,ZH,EN) HWK G	558748	●	●	●	AR, ZH, EN	20 cartridges 360 ml, 40 static mixer FIS MR Plus	1
FIS V Plus 360 S (DE,FR,NL) HWK G	558757	●	●	●	DE, FR, NL	20 cartridges 360 ml, 40 static mixer FIS MR Plus	1
FIS V Plus 360 S (EN,FR,AR)	560637	●	●	●	EN, FR, AR	20 cartridges 360 ml, 40 static mixer FIS MR Plus	1

Technical data

Injection mortar FIS VW Plus



FIS VW Plus 360 S HWK G

Item	Item No.	Approval			Languages on the cartridge	Contents	Sales unit [pcs]
		DIBt	ETA	ICC			
FIS VW Plus 360 S (DE) HWK G	558766	●	●	●	DE	20 cartridges 360 ml, 40 static mixer FIS MR Plus	1

Technical data

Injection mortar FIS V Plus



FIS V Plus 360 S BT

Item	Item No.	Approval			Languages on the cartridge	Contents	Sales unit [pcs]
		DIBt	ETA	ICC			
FIS V Plus 360 S (DE,FR,NL) BT	558763	●	●	●	DE, FR, NL	20 cartridges 360 ml, 20 static mixer FIS MR Plus	1
FIS V Plus 360 S (IN) BT	558743	●	●	●	EN	20 cartridges 360 ml, 40 static mixer FIS MR Plus	1
FIS V Plus 360 S (AR,ZH,EN) BT	558751	●	●	●	AR, ZH, EN	20 cartridges 360 ml, 20 static mixer FIS MR Plus	1
FIS V Plus 360 S (RU,UK,KK) BT	558772	●	●	●	RU, UK, KK	20 cartridges 360 ml, 40 static mixer FIS MR Plus	1
FIS VS Plus 360 S (EN,ES,PT) BT	562603	●	●	●	EN, ES, PT	20 cartridges 360 ml, 40 static mixer FIS MR Plus	1
FIS V Plus 360 S (IT,PL,RO) BT	562601	●	●	●	IT, PL, RO	20 cartridges 360 ml, 20 static mixer FIS MR Plus	1
FIS V Plus 360 S (EN,FR,AR) BT	560636	●	●	●	EN, FR, AR	20 cartridges 360 ml, 20 static mixer FIS MR Plus	1

Technical data

Injection mortar FIS V Plus



FIS V Plus 360 S HWK G +
FIS DM S

Item	Item No.	Approval			Languages on the cartridge	Contents	Sales unit [pcs]
		DIBt	ETA	ICC			
FIS V Plus 360 S (EN,ES,PT) HWK G + FIS DM S	558775	●	●	●	EN, ES, PT	12 cartridges 360 ml, 24 x FIS MR Plus, 1 x dispenser FIS DM S	1
FIS V Plus 360 S (DE,FR,NL) HWK G + FIS DM S	560032	●	●	●	DE, FR, NL	12 cartridges 360 ml, 24 x FIS MR Plus, 1 x dispenser FIS DM S	1
FIS V Plus 360 S (IT,PL,RO) HWK G + FIS DM S	558773	●	●	●	IT, PL, RO	12 cartridges 360 ml, 24 x FIS MR Plus, 1 x dispenser FIS DM S	1
FIS V Plus 360 S (CS,SK,HU) HWK G + FIS DM S	560033	●	●	●	CS, SK, HU	12 cartridges 360 ml, 24 x FIS MR Plus, 1 x dispenser FIS DM S	1

Technical data

Injection mortar FIS V Plus



FIS V Plus 410 C (IT,DE,EN)

Item	Item No.	Approval			Languages on the cartridge	Contents	Sales unit [pcs]
		DIBt	ETA	ICC			
FIS V Plus 410 C (EN,ES,PT)	558784	●	●	●	USA, RA, BR, MEX	1 cartridge 410 ml, 2 x FIS MR Plus	12
FIS V Plus 410 C (IT,DE,EN)	558780	●	●	●	IT, DE, EN	1 cartridge 410 ml, 2 x FIS MR Plus	12
FIS VW Plus 380 C (PL,CS,SK)	558785	●	●	●	PL, CS, SK	1 cartridge 380 ml, 2 x FIS MR Plus	12
FIS V Plus 410 C (IT,DE,EN) HWK G	558781	●	●	●	IT, DE, EN	16 cartridges 410 ml, 32 x FIS MR Plus	1
FIS V Plus 410 C (RU,EN,TR) BT	558783	●	●	●	RU, EN, TR	16 cartridges 410 ml, 32 x FIS MR Plus	1
FIS V Plus 410 C (IT,DE,EN) BT	558782	●	●	●	IT, DE, EN	16 cartridges 410 ml, 32 x FIS MR Plus	1

Technical data

Injection mortar FIS V Plus



Thermosafe case FIS V Plus

Item	Item No.	Approval			Contents	Sales unit [pcs]
		DIBt	ETA	ICC		
Thermosafe case FIS V Plus	558950	●	●	●	6 x cartridges 360 ml, 12 x static mixer FIS MR Plus, 1 x brush set, 1 x blow-out pump, 1 x dispenser FIS DM S	1

Curing times

FIS VW Plus High Speed FIS V Plus FIS VS Plus Low Speed									
Temperature at anchoring base [°C]	Maximum processing time t_{work}			Minimum curing time t_{cure} ¹⁾					
	FIS VW Plus High Speed [min.]	FIS V Plus [min.]	FIS VS Plus Low Speed [min.]	FIS VW Plus High Speed [hrs.]	FIS V Plus [min.]	FIS V Plus [hrs.]	FIS V Plus [min.]	FIS VS Plus Low Speed [hrs.]	FIS VS Plus Low Speed [min.]
-10 – -5 ²⁾	–	–	–	12	–	–	–	–	–
> -5 – 0 ²⁾	5	–	–	3	–	24	–	–	–
> 0 – +5 ²⁾	5	13	–	3	–	3	–	6	–
> +5 – +10	3	9	20	–	50	–	90	3	–
> +10 – +20	1	5	10	–	50	–	60	2	–
> +20 – +30	–	4	6	–	–	–	45	–	60
> +30 – +40	–	2	4	–	–	–	35	–	30

1) In wet concrete or water filled holes the curing times must be doubled.

2) Minimal cartridge temperature +5 °C

Loads

Injection system FIS V Plus with internal threaded anchor RG M I

Permissible loads of a single anchor^{1) 2)} in normal concrete of strength class C20/25.

For the design the complete current assessment ETA-20/0603 has to be considered.

Type	Screw Material ³⁾	Effective anchor- age depth h_{ef} [mm]	Minimum member thickness h_{min} [mm]	Maximum installa- tion torque $T_{inst, max}$ [Nm]	Non-cracked concrete			
					Permissible tension (N_{perm}) and shear loads (V_{perm}); minimum spacing (s_{min}) and edge distances (c_{min}) with reduced loads			
					N_{perm} ⁴⁾ [kN]	V_{perm} ⁴⁾ [kN]	s_{min} ⁴⁾ [mm]	c_{min} ⁴⁾ [mm]
RG M 8 I	5.8	90	120	10	9.0	5.3	55	55
	8.8	90	120	10	13.8	8.3	55	55
	R-70	90	120	10	9.9	5.9	55	55
RG M 10 I	5.8	90	130	20	13.8	8.3	65	65
	8.8	90	130	20	20.0	13.3	65	65
	R-70	90	130	20	15.7	9.3	65	65
RG M 12 I	5.8	125	170	40	20.5	12.1	75	75
	8.8	125	170	40	32.0	19.3	75	75
	R-70	125	170	40	22.5	13.5	75	75
RG M 16 I	5.8	160	210	80	37.6	22.4	95	95
	8.8	160	210	80	47.4	30.9	95	95
	R-70	160	210	80	42.0	25.1	95	95
RG M 20 I	5.8	200	260	120	58.6	35.4	125	125
	8.8	200	260	120	66.3	51.4	125	125
	R-70	200	260	120	65.7	39.4	125	125

¹⁾ Design according to EN 1992-4:2018 (for static resp. quasi-static loads). The partial safety factors for material resistance as regulated in the ETA as well as a partial safety factor for load actions of $\gamma_L = 1.4$ are considered. As a single anchor counts e.g. an anchor with a spacing $s \geq 3 \times h_{ef}$ and an edge distance $c \geq 1.5 \times h_{ef}$. Accurate data see ETA.

²⁾ The specified loads are valid for anchorages in dry and damp concrete. For temperatures in the anchoring substrate up to 50 °C (resp. short term up to 80 °C). Drill hole cleaning as per specification in the ETA. The factor Ψ_{SUS} for sustained load was taken into account with 1.0.

³⁾ Further steel grades, versions and technical data see ETA, e.g. for dry internal conditions, galvanised steel (gvz); for damp interiors and for outdoor use, stainless steel (R).

⁴⁾ In the case of combinations of tension and shear loads, bending moments with reduced or minimum spacing and edge distances (anchor groups), the design must be carried out in accordance with the provisions of the complete ETA and the provisions of the EN 1992-4:2018. We recommend using our anchor design software C-FIX.

Loads

Injection system FIS V Plus with threaded rod FIS A resp. RG M

Permissible loads of a single anchor^{1) 2)} in normal concrete of strength class C20/25.
For the design the complete current assessment ETA-20/0603 has to be considered.

Type	Material / surface ³⁾	Effective anchorage depth h_{ef} [mm]	Minimum member thickness h_{min} [mm]	Maximum installation torque $T_{inst, max}$ [Nm]	Cracked concrete				Non-cracked concrete			
					Permissible tension (N_{perm}) and shear loads (V_{perm}); minimum spacing (s_{min}) and edge distances (c_{min}) with reduced loads				Permissible tension (N_{perm}) and shear loads (V_{perm}); minimum spacing (s_{min}) and edge distances (c_{min}) with reduced loads			
					$N_{perm}^{4)}$ [kN]	$V_{perm}^{4)}$ [kN]	$s_{min}^{4)}$ [mm]	$c_{min}^{4)}$ [mm]	$N_{perm}^{4)}$ [kN]	$V_{perm}^{4)}$ [kN]	$s_{min}^{4)}$ [mm]	$c_{min}^{4)}$ [mm]
FIS A M 8	5.8	60	100	10	3.9	6.3	40	40	9.0	6.3	40	40
	5.8	80	110	10	5.3	6.3	40	40	9.0	6.3	40	40
	5.8	160	190	10	9.0	6.3	40	40	9.0	6.3	40	40
	R-70	60	100	10	3.9	6.0	40	40	9.9	6.0	40	40
	R-70	80	110	10	5.3	6.0	40	40	9.9	6.0	40	40
	R-70	160	190	10	9.9	6.0	40	40	9.9	6.0	40	40
FIS A M 10	5.8	60	100	20	5.4	9.7	45	45	10.9	9.7	45	45
	5.8	90	120	20	8.1	9.7	45	45	13.8	9.7	45	45
	5.8	200	230	20	13.8	9.7	45	45	13.8	9.7	45	45
	R-70	60	100	20	5.4	9.2	45	45	10.9	9.2	45	45
	R-70	90	120	20	8.1	9.2	45	45	15.7	9.2	45	45
	R-70	200	230	20	15.7	9.2	45	45	15.7	9.2	45	45
FIS A M 12	5.8	70	100	40	8.2	14.3	55	45	13.7	14.3	55	45
	5.8	110	140	40	12.8	14.3	55	45	20.5	14.3	55	45
	5.8	240	270	40	20.5	14.3	55	45	20.5	14.3	55	45
	R-70	70	100	40	8.2	13.7	55	45	13.7	13.7	55	45
	R-70	110	140	40	12.8	13.7	55	45	22.5	13.7	55	45
	R-70	240	270	40	22.5	13.7	55	45	22.5	13.7	55	45
FIS A M 16	5.8	80	120	60	11.5	23.0	65	50	16.8	26.9	65	50
	5.8	125	170	60	18.0	26.9	65	50	32.7	26.9	65	50
	5.8	320	360	60	37.6	26.9	65	50	37.6	26.9	65	50
	R-70	80	120	60	11.5	23.0	65	50	16.8	25.2	65	50
	R-70	125	170	60	18.0	25.2	65	50	32.7	25.2	65	50
	R-70	320	360	60	42.0	25.2	65	50	42.0	25.2	65	50
FIS A M 20	5.8	90	140	120	14.0	28.0	85	55	20.0	40.0	85	55
	5.8	170	220	120	28.0	42.3	85	55	51.9	42.3	85	55
	5.8	400	450	120	58.6	42.3	85	55	58.6	42.3	85	55
	R-70	90	140	120	14.0	28.0	85	55	20.0	39.4	85	55
	R-70	170	220	120	28.0	39.4	85	55	51.9	39.4	85	55
	R-70	400	450	120	65.7	39.4	85	55	65.7	39.4	85	55
FIS A M 24	5.8	96	160	150	15.4	30.8	105	60	22.0	44.1	105	60
	5.8	210	270	150	37.7	60.6	105	60	71.3	60.6	105	60
	5.8	480	540	150	84.3	60.6	105	60	84.3	60.6	105	60
	R-70	96	160	150	15.4	30.8	105	60	22.0	44.1	105	60
	R-70	210	270	150	37.7	56.8	105	60	71.3	56.8	105	60
	R-70	480	540	150	86.2	56.8	105	60	94.3	56.8	105	60
FIS A M 30	5.8	120	190	300	21.6	43.1	140	80	30.8	61.6	140	80
	5.8	280	350	300	56.5	96.0	140	80	109.8	96.0	140	80
	5.8	600	670	300	121.2	96.0	140	80	133.8	96.0	140	80
	R-70	120	190	300	21.6	43.1	140	80	30.8	61.6	140	80
	R-70	280	350	300	56.5	90.2	140	80	109.8	90.2	140	80
	R-70	600	670	300	121.2	90.2	140	80	150.1	90.2	140	80

¹⁾ Design according to EN 1992-4:2018 (for static resp. quasi-static loads). The partial safety factors for material resistance as regulated in the ETA as well as a partial safety factor for load actions of $\gamma_L = 1.4$ are considered. As a single anchor counts e.g. an anchor with a spacing $s \geq 3 \times h_{ef}$ and an edge distance $c \geq 1.5 \times h_{ef}$. Accurate data see ETA.

²⁾ The specified loads are valid for anchorages in dry and damp concrete. For temperatures in the anchoring substrate up to 50 °C (resp. short term up to 80 °C). Drill hole cleaning as per specification in the ETA. The factor Ψ_{sus} for sustained load was taken into account with 1.0.

³⁾ Further steel grades, versions and technical data see ETA, e.g. for dry internal conditions, galvanised steel (gvz); for damp interiors and for outdoor use, stainless steel (R).

⁴⁾ In the case of combinations of tension and shear loads, bending moments with reduced or minimum spacing and edge distances (anchor groups), the design must be carried out in accordance with the provisions of the complete ETA and the provisions of the EN 1992-4:2018. We recommend using our anchor design software C-FIX.

Loads

Injection system FIS V Plus with threaded rod FIS A in solid and perforated masonry

Permissible loads^{1) 2)} for a single anchor in masonry for pre-positioned installation.
For the design the complete current assessment ETA-20/0729 has to be considered.

Type	Compressive brick strength f_b [N/mm ²]	Brick raw density ρ [kg/dm ³]	Minimum brick dimensions ³⁾ (L x W x H) [mm]	Effective anchorage depth h_{ef} [mm]	Minimum member thickness h_{min} [mm]	Maximum installation torque $T_{inst,max}$ [Nm]	Permissible tensile load ⁴⁾ N_{perm} [kN]	Permissible shear load ⁴⁾ V_{perm} [kN]	Minimum spacing ⁵⁾ $S_{min, \parallel} / S_{min, \perp}$ [mm]	Characteristic resp. minimum edge distance ⁶⁾ $c_{cr} = c_{min}$ [mm]
Solid brick Mz, NF, acc. to EN 771-1										
M6	≥ 12	≥ 1.8	240 x 115 x 71	≥ 50	115	4	1.14	0.71	240 / 75	100
M8	≥ 12	≥ 1.8	240 x 115 x 71	≥ 50	115	10	1.14	0.71	240 / 75	100
M10	≥ 12	≥ 1.8	240 x 115 x 71	80	115	10	1.42	1.14	240 / 75	100
M10	≥ 12	≥ 1.8	240 x 115 x 71	200	240	10	3.43	2.43	240 / 75	100
M12	≥ 12	≥ 1.8	240 x 115 x 71	80	115	10	1.57	1.14	240 / 75	100
M12	≥ 12	≥ 1.8	240 x 115 x 71	200	240	10	2.29	3.28	240 / 75	100
Solid sand-lime brick KS, acc. to EN 771-2										
M6	≥ 12	≥ 1.8	240 x 115 x 71	50	115	3	1.14	0.42	80 / 150	60
M6	≥ 12	≥ 1.8	240 x 115 x 71	100	115	3	1.57	0.89	80 / 300	60
M8	≥ 12	≥ 1.8	240 x 115 x 71	50	115	5	1.14	0.42	80 / 150	60
M8	≥ 12	≥ 1.8	240 x 115 x 71	100	115	5	2.29	0.89	80 / 300	60
M10	≥ 12	≥ 1.8	240 x 115 x 71	100	115	15	1.57	0.57	80 / 300	60
M10	≥ 12	≥ 1.8	240 x 115 x 71	200	240	15	3.42	0.57	80 / 600	60
M12	≥ 12	≥ 1.8	240 x 115 x 71	100	115	15	1.28	0.57	80 / 300	60
M12	≥ 12	≥ 1.8	240 x 115 x 71	200	240	15	3.42	0.57	80 / 600	60
M16	≥ 12	≥ 1.8	240 x 115 x 71	100	115	25	1.57	0.57	80 / 300	60
M16	≥ 12	≥ 1.8	240 x 115 x 71	200	240	25	3.42	0.57	80 / 600	60
Vertically perforated brick Hlz, acc. to EN 771-1⁹⁾										
M6 / M8 with FIS H 12 x 85 K	≥ 12	≥ 1.0	370 x 240 x 237	85	240	2	0.34	0.43	100 / 100	100
M8 / M10 with FIS H 16 x 130 K	≥ 12	≥ 1.0	370 x 240 x 237	130	240	2	0.86	0.57	100 / 100	100
M12 / M16 with FIS H 20 x 130 K	≥ 12	≥ 1.0	370 x 240 x 237	130	240	2	1.14	0.57	100 / 100	100
Perforated sand-lime brick KSL, acc. to EN 771-2³⁾										
M6 / M8 with FIS H 12 x 85 K	≥ 12	≥ 1.4	240 x 175 x 113	85	175	2	0.71	0.71	100 / 115	60
M8 / M10 with FIS H 16 x 130 K	≥ 12	≥ 1.4	240 x 175 x 113	130	175	2	1.00	1.29	100 / 115	80
M12 / M16 with FIS H 20 x 85 K	≥ 12	≥ 1.4	240 x 175 x 113	85	175	2	1.00	1.14	100 / 115	80
Lightweight concrete hollow block Hbl, acc. EN 771-3³⁾										
M6 / M8 with FIS H 12 x 85 K	≥ 2	≥ 1.0	362 x 240 x 240	85	240	2	0.43	0.26	100 / 240	60
M6 / M8 with FIS H 12 x 85 K	≥ 4	≥ 1.0	362 x 240 x 240	85	240	2	0.86	0.57	100 / 240	60
M8 / M10 with FIS H 16 x 85 K	≥ 2	≥ 1.0	362 x 240 x 240	85	240	2	0.43	0.26	100 / 240	60
M8 / M10 with FIS H 16 x 85 K	≥ 4	≥ 1.0	362 x 240 x 240	85	240	2	0.86	0.57	100 / 240	60
M12 / M16 with FIS H 20 x 200 K	≥ 2	≥ 1.0	362 x 240 x 240	200	240	2	0.71	0.26	100 / 240	60
M12 / M16 with FIS H 20 x 200 K	≥ 4	≥ 1.0	362 x 240 x 240	200	240	2	1.57	0.57	100 / 240	60
Aerated concrete acc. to EN 771-4⁶⁾										
M8	≥ 2	≥ 0.35	-	100	130	1	0.54	0.43	250 / 250	100
M8	≥ 4	≥ 0.50	-	200	230	8	1.07	0.71	80 / 80	100
M10	≥ 2	≥ 0.35	-	100	130	2	0.54	0.43	250 / 250	100
M10	≥ 4	≥ 0.50	-	200	230	12	1.79	0.71	80 / 80	100
M12	≥ 2	≥ 0.35	-	100	130	2	0.71	0.54	250 / 250	100
M12	≥ 4	≥ 0.50	-	200	230	16	1.79	0.71	80 / 80	100
M16	≥ 2	≥ 0.35	-	100	130	2	0.71	0.43	250 / 250	100
M16	≥ 4	≥ 0.50	-	200	230	20	1.79	0.71	80 / 80	100

¹⁾ The required partial safety factors for material resistance as well as a partial safety factor for load actions of $\gamma_L = 1.4$ are considered. Load values are valid for zinc-plated steel, stainless steel R and highly corrosion-resistant steel HCR. In perforated bricks and hollow blocks threaded rod FIS A in combination with anchor sleeve FIS H K.

²⁾ The given loads are valid for installation and use of fixations in dry masonry - use category d/d - for temperatures in the substrate up to 50 °C (resp. short term up to 80 °C) and drill hole cleaning according to assessment. The given brick types in combination with the permissible loads are an extract of the assessment.

³⁾ More information about, e.g. hole patterns, assortment of anchor sleeves FIS H K see assessment.

⁴⁾ In the case of combinations of tensile and shear loads, bending moments and reduced edge and axial spacings (anchor groups), the design must be carried out in accordance with the provisions of the complete assessment.

⁵⁾ Minimum feasible spacing resp. edge distance. Details as well as to the distances to joints see assessment.

⁶⁾ Cylindrical drill hole.

Injection mortar FIS V

The versatile injection mortar for anchorings in masonry and cracked concrete



Rescue ladders



Column bases

3

Applications

Injection mortar for use with:

- Threaded rods FIS A, see page 128
- Internal threaded anchor RG MI, see page 142
- Rebar anchor FRA, see page 170
- Concrete steel bars, see page 177
- Injection anchor sleeves FIS H, see page 149
- Aerated concrete centring sleeve PBZ, see page 194
- Remedial wall tie VBS 8, see page 179
- Weather facing reconstruction system FWS II, see page 181
- Anchorings in waterfilled drill holes (only FIS V 410 C)

Advantages

- The FIS V injection mortar has numerous system approvals, such as in cracked and non-cracked concrete, masonry and for special applications. FIS V is thus the universal injection mortar family with guaranteed reliability for practically all areas of application.
- FIS VW HIGH SPEED has a significantly shorter curing time than FIS V, thus also ensuring swift work progress even at low

temperatures.

- FIS VS LOW SPEED with extended gelling time prevents premature curing of the mortar at higher temperatures and is ideally suited to large drill hole depths.
- The extensive range of accessories is ideally suited to the FIS V injection mortar family, increases the great flexibility of the system and thus allows for a broad range of applications.

Certificates



ETA-02/0024, for cracked concrete



See ICC-ES Evaluation Report at www.icc-es.org

ETA-08/0266, Post-installed rebar connections

ETA-10/0383, for masonry



Fire resistance classification R120



Building materials

Approved for anchorings in:

- Concrete C20/25 to C50/60, cracked and non-cracked
- Hollow blocks made from lightweight concrete
- Hollow blocks made from concrete
- Vertically perforated brick
- Perforated sand-lime brick
- Solid sand-lime brick
- Aerated concrete
- Solid brick

Approved for:

- Rebar connections
- Remedial wall tie VBS 8
- Weather facing reconstruction system FWS II
- Stand-off installation TherMax

Functioning

- The FIS V is a 2-component injection mortar based on vinyl ester hybrid.
- Resin and hardener are stored in two separate chambers and are not mixed and activated until extrusion through the static mixer.
- The injection cartridges are quick and easy to use with the fischer dispensers.
- Partially used cartridges can be reused, simply by changing the static mixer.

For use with

Anchors & sleeves page 126



Dispenser page 189



Accessories page 194



Installation in concrete with FIS V and FIS A / RG M

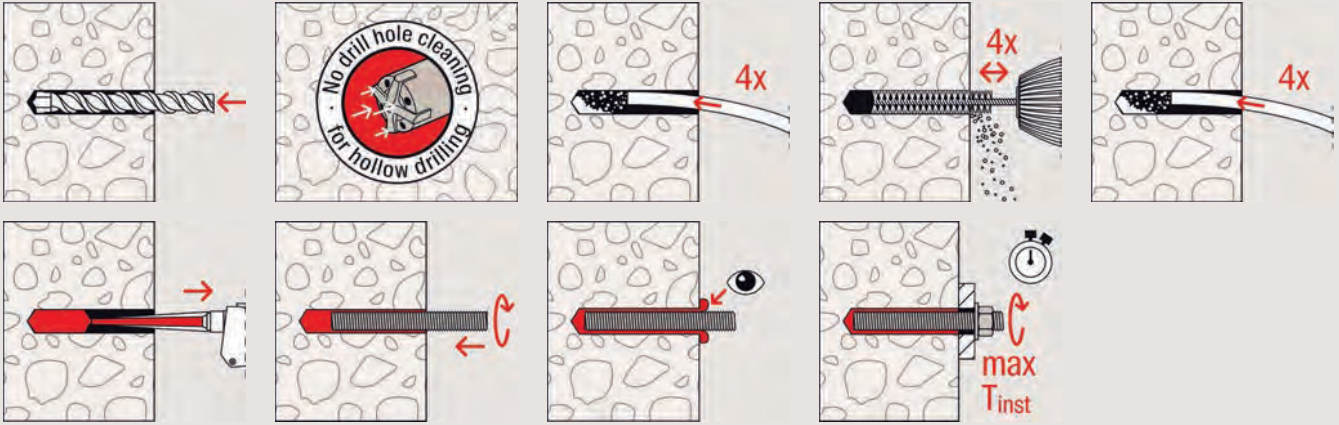

Installation in concrete with FIS V and RG M I

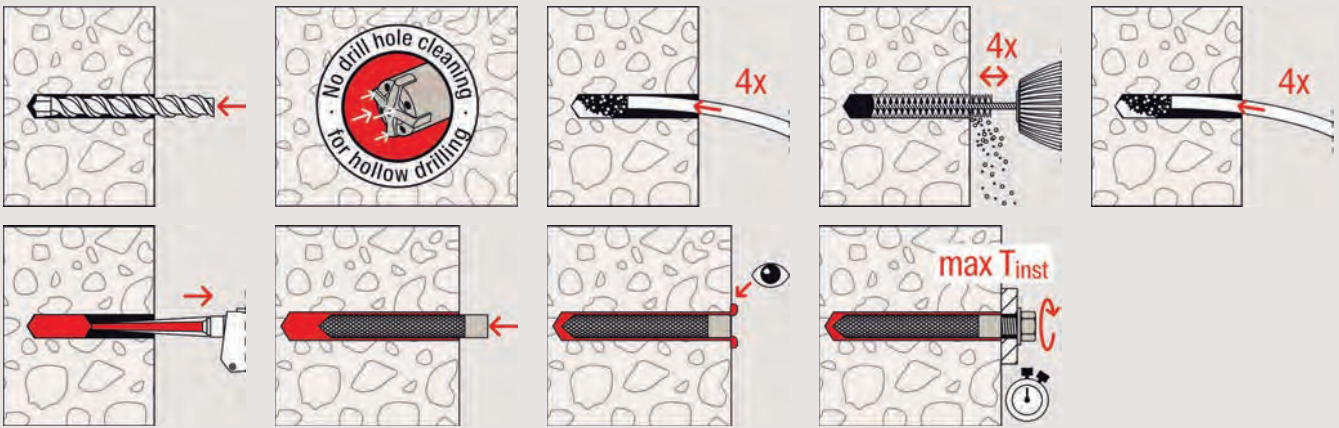

Installation in solid brick with FIS V and FIS A

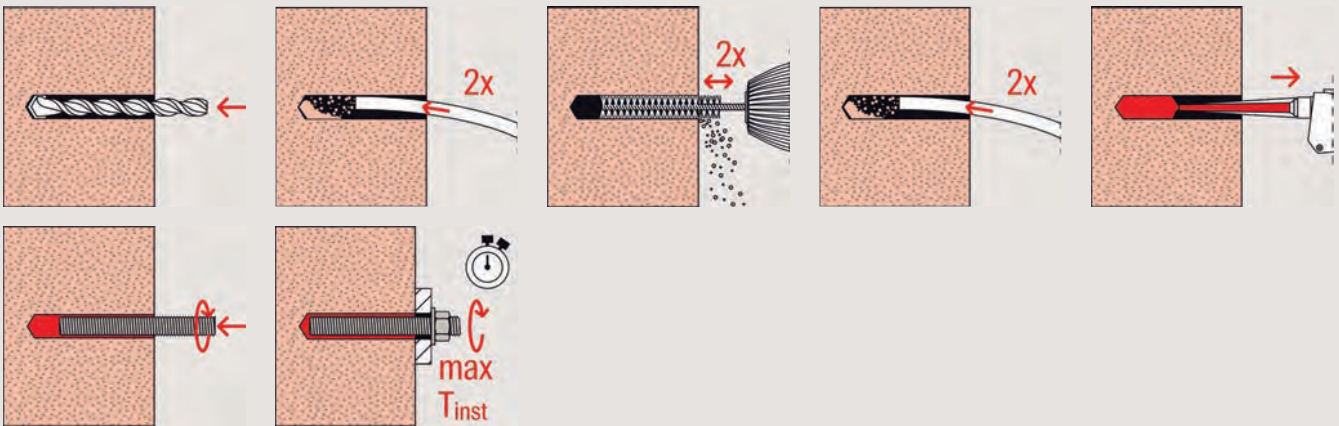

Installation in hollow blocks with FIS V and FIS HK + FIS A

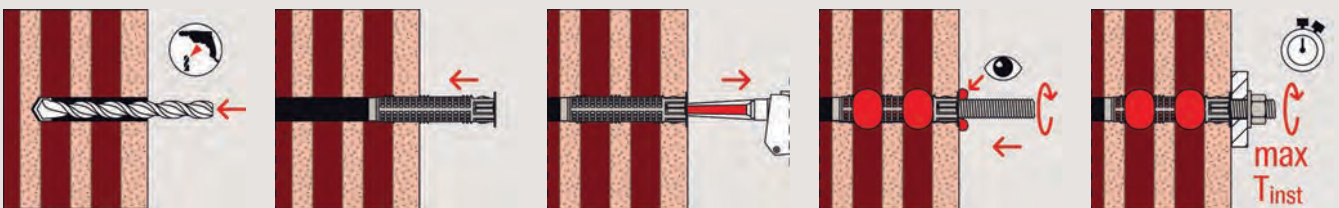

Installation in aerated concrete with FIS V and FIS A / RG M

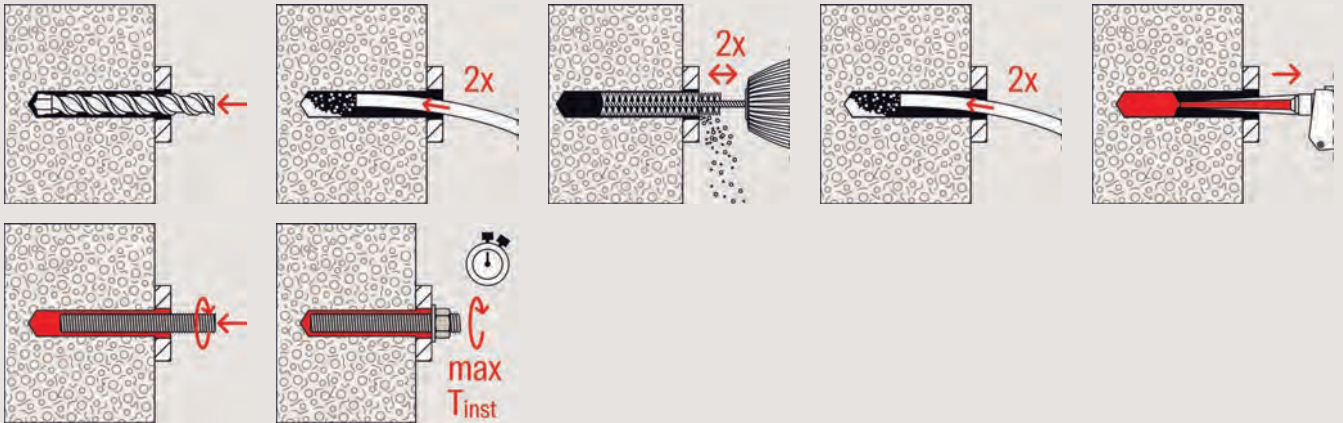

3

Installation in undercut drill hole in aerated concrete with FIS V and FIS A / RG M

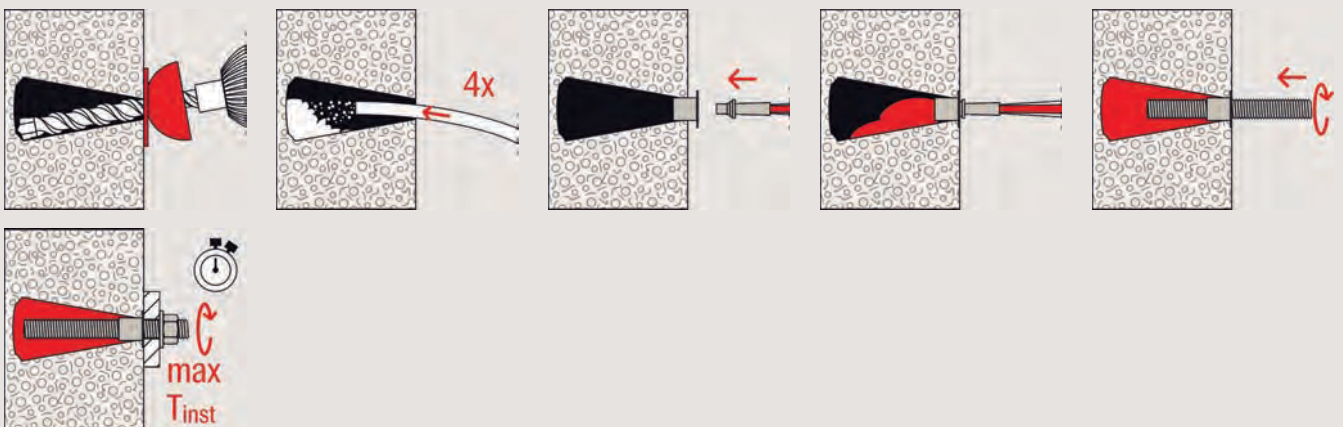

Technical data

Injection mortar FIS V



FIS V 300 T

FIS V 360 S

FIS V 410 C

FIS MR Plus

Item	Item No.	Approval			Languages on the cartridge	Scale unit	Contents	Sales unit [pcs]
		DIBt	ETA	ICC				
FIS V 300 T	531573	●	●	●	USA, RA, BR, MEX	150	1 cartridge 300 ml, 2 x FIS MR Plus	12
FIS V 360 S	559429	●	●	●	DE, FR, NL	180	1 cartridge 360 ml, 2 x FIS MR Plus	6
FIS V 360 S	559131	●	●	●	EN, ES, PT	180	1 cartridge 360 ml, 2 x FIS MR Plus	6
FIS V 360 S	559132	●	●	●	DK, NO, SE, FI	180	1 cartridge 360 ml, 2 x FIS MR Plus	6
FIS V 360 S	559435	●	●	●	IT, PL, RO	180	1 cartridge 360 ml, 2 x FIS MR Plus	6
FIS V 360 S	559432	●	●	●	RU, UK, KK	180	1 cartridge 360 ml, 2 x FIS MR Plus	6
FIS V 360 S	561056	●	●	●	PL, EN, RU	180	1 cartridge 360 ml, 2 x FIS MR Plus	6
FIS V 360 S	559133	●	●	●	CS, SK, HU	180	1 cartridge 360 ml, 2 x FIS MR Plus	6
FIS V 410 C	521431	●	●	●	IT, DE, EN	200	1 cartridge 410 ml, 2 x FIS MR Plus	12
FIS V 410 C	534880	●	●	●	PL, LT, LV, ET, RU	200	1 cartridge 410 ml, 2 x FIS MR Plus	12
FIS V 410 C	538131	●	●	●	USA, RA, BR, MEX	200	1 cartridge 410 ml, 2 x FIS MR Plus	12
FIS MR Plus	545853	—	—	—	—	—	10 static mixer FIS MR Plus	10

Technical data

Injection mortar FIS VW



FIS VW 300 T

FIS VW 360 S

FIS VW 380 C

FIS MR Plus

Item	Item No.	Approval		Languages on the cartridge	Scale unit	Contents	Sales unit [pcs]
		DIBt	ETA				
FIS VW HIGH SPEED 300 T	507793	●	●	DE, EN, HR, SL, SR, IT	150	1 cartridge 300 ml, 2 x FIS MR Plus	12
FIS VW HIGH SPEED 300 T	507795	●	●	SV, DA, NO, CS, SK, PL, RU	150	1 cartridge 360 ml, 2 x FIS MR Plus	12
FIS VW 360 S	559134	●	●	EN, HU	180	1 cartridge 360 ml, 2 x FIS MR Plus	6
FIS VW 360 S	559436	●	●	PL, CS, RO	180	1 cartridge 360 ml, 2 x FIS MR Plus	6
FIS VW 360 S	559437	●	●	DE, FR, NL	180	1 cartridge 360 ml, 2 x FIS MR Plus	6
FIS VW 360 S	559433	●	●	RU, UK, KK	180	1 cartridge 360 ml, 2 x FIS MR Plus	6
FIS VW HIGH SPEED 380 C	519328	—	●	CS, SK, PL	190	1 cartridge 380 ml, 2 x FIS MR Plus	12
FIS MR Plus	545853	—	—	—	—	10 static mixer FIS MR Plus	10

Technical data

Injection mortar FIS VS LOW SPEED



FIS VS 100 P

FIS VS 150 C

FIS VS 300 T

FIS MR Plus

Item	Item No.	Approval		Languages on the cartridge	Scale unit	Contents	Sales unit [pcs]
		ETA	ICC				
FIS VS LOW SPEED 100 P	072525	●	●	DE, EN, FR, IT, NL, ES	50	1 cartridge 100 ml, 2 x FIS MR Plus	6
FIS VS 150 C	045302	●	●	DE, EN, FR, IT, NL, ES	70	1 cartridge 145 ml, 2 x FIS MR Plus	6
FIS VS 150 C Set	045303	●	●	DE, EN, FR, IT, NL, ES	70	Set for hollow bricks: 1 cartridge 145 ml, 2 x FIS MR Plus, 6 x FIS H 16 x 85 K	6
FIS VS LOW SPEED 300 T	093180	●	●	DE, EN, FR, NL, ES, PT	150	1 cartridge 300 ml, 2 x FIS MR Plus	12
FIS VS LOW SPEED 300 T	502285	●	●	RU, LT, LV, ET, UK, KK	150	1 cartridge 300 ml, 2 x FIS MR Plus	12
FIS VS LOW SPEED 300 T	044102	●	●	CS, SK, PL, HU, RO, RU, EL	150	1 cartridge 300 ml, 2 x FIS MR Plus	12
FIS VS LOW SPEED 300 T	093226	●	●	PL, CS, DA, NO, SV, FI	150	1 cartridge 300 ml, 2 x FIS MR Plus	12
FIS MR Plus	545853	—	—	—	—	10 static mixer FIS MR Plus	10

Technical data

Injection mortar FIS V



FIS V 360 S HWK small

FIS V 360 S HWK big

Item	Item No.	Approval			Languages on the cartridge	Contents	Sales unit [pcs]
		DIBt	ETA	ICC			
FIS V 360 S HWK small	559431	●	●	●	DE, FR, NL	10 cartridges 360 ml, 20 x FIS MR Plus	6
FIS V 360 S HWK big	559430	●	●	●	DE, FR, NL	20 cartridges 360 ml, 40 x FIS MR Plus	6
FIS V 360 S HWK big	559135	●	●	●	CS, SK, HU	20 cartridges 360 ml, 40 x FIS MR Plus	6

Technical data

Injection mortar FIS V



FIS V 360 S in bucket

Item	Item No.	Approval			Languages on the cartridge	Contents	Sales unit [pcs]
		DIBt	ETA	ICC			
FIS V 360 S in bucket	559434	●	●	●	DE, FR, NL	20 cartridges 360 ml, 20 x FIS MR Plus	1
FIS V 410 in bucket	531504	●	●	●	EN, TR, RU	16 cartridges 410 ml, 32 x FIS MR Plus	1

Technical data

Injection mortar FIS VS LOW SPEED



FIS VS 300 T in bucket



FIS VS 300 T HWK big



FIS VS 300 T HWK small

Item	Item No.	Approval		Languages on the cartridge	Contents	Sales unit [pcs]
		ETA	ICC			
FIS VS LOW SPEED 300 T in bucket	518539	●	●	CS, SK, PL, HU, RO, EL	20 cartridges 300 ml, 20 x FIS MR Plus	1
FIS VS LOW SPEED 300 T HWK big	517645	●	●	DE, EN, FR, NL, ES, PT	20 cartridges 300 ml, 40 x FIS MR Plus	1
FIS VS LOW SPEED 300 T HWK small	518832	●	●	DE, EN, FR, NL, ES, PT	10 cartridges 300 ml, 20 x FIS MR Plus	1

Curing times

Temperature at anchoring base [°C]	Maximum processing time t_{work}			Minimum curing time t_{cure} ¹⁾					
	FIS VW High Speed	FIS V	FIS VS Low Speed	FIS VW High Speed		FIS V		FIS VS Low Speed	
	[min.]	[min.]	[min.]	[hrs.]	[min.]	[hrs.]	[min.]	[hrs.]	[min.]
-10 – -5 ²⁾	–	–	–	12	–	–	–	–	–
> -5 – 0 ²⁾	5	–	–	3	–	24	–	–	–
> 0 – +5 ²⁾	5	13	–	3	–	3	–	6	–
> +5 – +10	3	9	20	–	50	–	90	3	–
> +10 – +20	1	5	10	–	50	–	60	2	–
> +20 – +30	–	4	6	–	–	–	45	–	60
> +30 – +40	–	2	4	–	–	–	35	–	30

1) In wet concrete or water filled holes the curing times must be doubled.

2) Minimal cartridge temperature +5 °C

Loads

Injection system FIS V with threaded rod FIS A in solid and perforated masonry

Permissible loads^{1) 2)} for a single anchor in masonry for pre-positioned installation.
For the design the complete current assessment ETA-10/0383 has to be considered.

Type	Compressive brick strength f_b [N/mm ²]	Brick raw density ρ [kg/dm ³]	Minimum brick dimensions ³⁾ (L x W x H) [mm]	Effective anchorage depth h_{ef} [mm]	Minimum member thickness h_{min} [mm]	Maximum installation torque $T_{inst,max}$ [Nm]	Permissible tensile load ⁴⁾ N_{perm} [kN]	Permissible shear load ⁴⁾ V_{perm} [kN]	Minimum spacing ⁵⁾ $S_{min, \parallel}$ / $S_{min, \perp}$ [mm]	Characteristic resp. minimum edge distance ⁶⁾ $c_{cr} = c_{min}$ [mm]
Solid brick Mz, NF, acc. to EN 771-1										
M6	≥ 12	≥ 1.8	240 x 115 x 71	≥ 50	115	4	1.14	0.71	240 / 75	100
M8	≥ 12	≥ 1.8	240 x 115 x 71	≥ 50	115	10	1.14	0.71	240 / 75	100
M10	≥ 12	≥ 1.8	240 x 115 x 71	80	115	10	1.42	1.14	240 / 75	100
M10	≥ 12	≥ 1.8	240 x 115 x 71	200	240	10	3.43	2.43	240 / 75	100
M12	≥ 12	≥ 1.8	240 x 115 x 71	80	115	10	1.57	1.14	240 / 75	100
M12	≥ 12	≥ 1.8	240 x 115 x 71	200	240	10	2.29	3.28	240 / 75	100
Solid sand-lime brick KS, acc. to EN 771-2										
M6	≥ 12	≥ 1.8	240 x 115 x 71	50	115	3	1.14	0.42	80 / 150	60
M6	≥ 12	≥ 1.8	240 x 115 x 71	100	115	3	1.57	0.89	80 / 300	60
M8	≥ 12	≥ 1.8	240 x 115 x 71	50	115	5	1.14	0.42	80 / 150	60
M8	≥ 12	≥ 1.8	240 x 115 x 71	100	115	5	2.29	0.89	80 / 300	60
M10	≥ 12	≥ 1.8	240 x 115 x 71	100	115	15	1.57	0.57	80 / 300	60
M10	≥ 12	≥ 1.8	240 x 115 x 71	200	240	15	3.42	0.57	80 / 600	60
M12	≥ 12	≥ 1.8	240 x 115 x 71	100	115	15	1.28	0.57	80 / 300	60
M12	≥ 12	≥ 1.8	240 x 115 x 71	200	240	15	3.42	0.57	80 / 600	60
M16	≥ 12	≥ 1.8	240 x 115 x 71	100	115	25	1.57	0.57	80 / 300	60
M16	≥ 12	≥ 1.8	240 x 115 x 71	200	240	25	3.42	0.57	80 / 600	60
Vertically perforated brick Hz, acc. to EN 771-1⁹⁾										
M6 / M8 with FIS H 12 x 85 K	≥ 12	≥ 1.0	370 x 240 x 237	85	240	2	0.34	0.43	100 / 100	100
M8 / M10 with FIS H 16 x 130 K	≥ 12	≥ 1.0	370 x 240 x 237	130	240	2	0.86	0.57	100 / 100	100
M12 / M16 with FIS H 20 x 130 K	≥ 12	≥ 1.0	370 x 240 x 237	130	240	2	1.14	0.57	100 / 100	100
Perforated sand-lime brick KSL, acc. to EN 771-2³⁾										
M6 / M8 with FIS H 12 x 85 K	≥ 12	≥ 1.4	240 x 175 x 113	85	175	2	0.71	0.71	100 / 115	60
M8 / M10 with FIS H 16 x 130 K	≥ 12	≥ 1.4	240 x 175 x 113	130	175	2	1.00	1.29	100 / 115	80
M12 / M16 with FIS H 20 x 85 K	≥ 12	≥ 1.4	240 x 175 x 113	85	175	2	1.00	1.14	100 / 115	80
Lightweight concrete hollow block Hbl, acc. EN 771-3³⁾										
M6 / M8 with FIS H 12 x 85 K	≥ 2	≥ 1.0	362 x 240 x 240	85	240	2	0.43	0.26	100 / 240	60
M6 / M8 with FIS H 12 x 85 K	≥ 4	≥ 1.0	362 x 240 x 240	85	240	2	0.86	0.57	100 / 240	60
M8 / M10 with FIS H 16 x 85 K	≥ 2	≥ 1.0	362 x 240 x 240	85	240	2	0.43	0.26	100 / 240	60
M8 / M10 with FIS H 16 x 85 K	≥ 4	≥ 1.0	362 x 240 x 240	85	240	2	0.86	0.57	100 / 240	60
M12 / M16 with FIS H 20 x 200 K	≥ 2	≥ 1.0	362 x 240 x 240	200	240	2	0.71	0.26	100 / 240	60
M12 / M16 with FIS H 20 x 200 K	≥ 4	≥ 1.0	362 x 240 x 240	200	240	2	1.57	0.57	100 / 240	60
Aerated concrete acc. to EN 771-4⁶⁾										
M8	≥ 2	≥ 0.35	-	100	130	1	0.54	0.43	250 / 250	100
M8	≥ 4	≥ 0.50	-	200	230	8	1.07	0.71	80 / 80	100
M10	≥ 2	≥ 0.35	-	100	130	2	0.54	0.43	250 / 250	100
M10	≥ 4	≥ 0.50	-	200	230	12	1.79	0.71	80 / 80	100
M12	≥ 2	≥ 0.35	-	100	130	2	0.71	0.54	250 / 250	100
M12	≥ 4	≥ 0.50	-	200	230	16	1.79	0.71	80 / 80	100
M16	≥ 2	≥ 0.35	-	100	130	2	0.71	0.43	250 / 250	100
M16	≥ 4	≥ 0.50	-	200	230	20	1.79	0.71	80 / 80	100

¹⁾ The required partial safety factors for material resistance as well as a partial safety factor for load actions of $\gamma_L = 1.4$ are considered. Load values are valid for zinc-plated steel, stainless steel R and highly corrosion-resistant steel HCR. In perforated bricks and hollow blocks threaded rod FIS A in combination with anchor sleeve FIS H K.

²⁾ The given loads are valid for installation and use of fixations in dry masonry - use category d/d - for temperatures in the substrate up to 50 °C (resp. short term up to 80 °C) and drill hole cleaning according to assessment. The given brick types in combination with the permissible loads are an extract of the assessment.

³⁾ More information about, e.g. hole patterns, assortment of anchor sleeves FIS H K see assessment.

⁴⁾ In the case of combinations of tensile and shear loads, bending moments and reduced edge and axial spacings (anchor groups), the design must be carried out in accordance with the provisions of the complete assessment.

⁵⁾ Minimum feasible spacing resp. edge distance. Details as well as to the distances to joints see assessment.

⁶⁾ Cylindrical drill hole.

Loads

Injection system FIS V with threaded rod FIS A

Permissible loads of a single anchor^{1) 2)} in normal concrete of strength class C20/25.
For the design the complete current assessment ETA-02/0024 has to be considered.

Type	Material / surface ³⁾	Effective anchorage depth h_{ef} [mm]	Minimum member thickness h_{min} [mm]	Maximum installation torque $T_{inst, max}$ [Nm]	Cracked concrete				Non-cracked concrete			
					Permissible tension (N_{perm}) and shear loads (V_{perm}); minimum spacing (s_{min}) and edge distances (c_{min}) with reduced loads				Permissible tension (N_{perm}) and shear loads (V_{perm}); minimum spacing (s_{min}) and edge distances (c_{min}) with reduced loads			
					$N_{perm}^{4)}$ [kN]	$V_{perm}^{4)}$ [kN]	$s_{min}^{4)}$ [mm]	$c_{min}^{4)}$ [mm]	$N_{perm}^{4)}$ [kN]	$V_{perm}^{4)}$ [kN]	$s_{min}^{4)}$ [mm]	$c_{min}^{4)}$ [mm]
FIS A M 8	5.8	60	100	10	3.9	6.3	40	40	7.9	6.3	40	40
	5.8	80	110	10	5.3	6.3	40	40	9.0	6.3	40	40
	5.8	160	190	10	9.0	6.3	40	40	9.0	6.3	40	40
	R-70	60	100	10	3.9	6.0	40	40	7.9	6.0	40	40
	R-70	80	110	10	5.3	6.0	40	40	9.9	6.0	40	40
	R-70	160	190	10	9.9	6.0	40	40	9.9	6.0	40	40
FIS A M 10	5.8	60	100	20	5.4	9.7	45	45	9.9	9.7	45	45
	5.8	90	120	20	8.1	9.7	45	45	13.8	9.7	45	45
	5.8	200	230	20	13.8	9.7	45	45	13.8	9.7	45	45
	R-70	60	100	20	5.4	9.2	45	45	9.9	9.2	45	45
	R-70	90	120	20	8.1	9.2	45	45	14.8	9.2	45	45
	R-70	200	230	20	15.7	9.2	45	45	15.7	9.2	45	45
FIS A M 12	5.8	70	100	40	7.5	14.3	55	55	13.7	14.3	55	55
	5.8	110	140	40	11.8	14.3	55	55	20.5	14.3	55	55
	5.8	240	270	40	20.5	14.3	55	55	20.5	14.3	55	55
	R-70	70	100	40	7.5	13.7	55	55	13.7	13.7	55	55
	R-70	110	140	40	11.8	13.7	55	55	21.7	13.7	55	55
	R-70	240	270	40	22.5	13.7	55	55	22.5	13.7	55	55
FIS A M 16	5.8	80	120	60	11.5	23.0	65	65	16.8	26.9	65	65
	5.8	125	170	60	18.0	26.9	65	65	29.9	26.9	65	65
	5.8	320	360	60	37.6	26.9	65	65	37.6	26.9	65	65
	R-70	80	120	60	11.5	23.0	65	65	16.8	25.2	65	65
	R-70	125	170	60	18.0	25.2	65	65	29.9	25.2	65	65
	R-70	320	360	60	42.0	25.2	65	65	42.0	25.2	65	65
FIS A M 20	5.8	90	140	120	14.0	28.0	85	85	20.0	40.0	85	85
	5.8	170	220	120	28.0	42.3	85	85	48.3	42.3	85	85
	5.8	400	450	120	58.6	42.3	85	85	58.6	42.3	85	85
	R-70	90	140	120	14.0	28.0	85	85	20.0	39.4	85	85
	R-70	170	220	120	28.0	39.4	85	85	48.3	39.4	85	85
	R-70	400	450	120	65.7	39.4	85	85	65.7	39.4	85	85
FIS A M 24	5.8	96	160	150	15.4	30.8	105	105	22.0	44.1	105	105
	5.8	210	270	150	33.9	60.6	105	105	67.9	60.9	105	105
	5.8	480	540	150	77.6	60.6	105	105	84.3	60.9	105	105
	R-70	96	160	150	15.4	30.8	105	105	22.0	44.1	105	105
	R-70	210	270	150	33.9	56.8	105	105	67.9	56.8	105	105
	R-70	480	540	150	77.6	56.8	105	105	94.3	56.8	105	105
FIS A M 30	5.8	120	190	300	21.5	43.1	140	140	30.8	61.6	140	140
	5.8	280	350	300	50.3	96.0	140	140	106.8	96.0	140	140
	5.8	600	670	300	107.7	96.0	140	140	133.8	96.0	140	140
	R-70	120	190	300	21.5	43.1	140	140	30.8	61.6	140	140
	R-70	280	350	300	50.3	90.2	140	140	106.8	90.2	140	140
	R-70	600	670	300	107.7	90.2	140	140	150.1	90.2	140	140

¹⁾ Design according to EN 1992-4:2018 (for static resp. quasi-static loads). The partial safety factors for material resistance as regulated in the ETA as well as a partial safety factor for load actions of $\gamma_L = 1.4$ are considered. As a single anchor counts e.g. an anchor with a spacing $s \geq 3 \times h_{ef}$ and an edge distance $c \geq 1.5 \times h_{ef}$. Accurate data see ETA.

²⁾ The specified loads are valid for anchorages in dry and damp concrete. For temperatures in the anchoring substrate up to 50 °C (resp. short term up to 80 °C). Drill hole cleaning as per specification in the ETA. The factor Ψ_{sus} for sustained load was taken into account with 1.0.

³⁾ Further steel grades, versions and technical data see ETA, e.g. for dry internal conditions, galvanised steel (gvz); for damp interiors and for outdoor use, stainless steel (R).

⁴⁾ In the case of combinations of tension and shear loads, bending moments with reduced or minimum spacing and edge distances (anchor groups), the design must be carried out in accordance with the provisions of the complete ETA and the provisions of the EN 1992-4:2018. We recommend using our anchor design software C-FIX.

Loads

Injection system FIS V with internal threaded anchor RG M I

Permissible loads of a single anchor^{1) 2)} in normal concrete of strength class C20/25.
For the design the complete current assessment ETA-02/0024 has to be considered.

Type	Screw Material ³⁾	Effective anchorage depth h_{ef} [mm]	Minimum member thickness h_{min} [mm]	Maximum Installation torque $T_{inst, max}$ [Nm]	Non-cracked concrete			
					Permissible tension (N_{perm}) and shear loads (V_{perm}); minimum spacing (s_{min}) and edge distances (c_{min}) with reduced loads			
					$N_{perm}^{4)}$ [kN]	$V_{perm}^{4)}$ [kN]	$s_{min}^{4)}$ [mm]	$c_{min}^{4)}$ [mm]
RG M 8 I	5.8	90	120	10	9.0	5.3	55	55
	8.8	90	120	10	13.8	8.3	55	55
	R-70	90	120	10	9.9	5.9	55	55
RG M 10 I	5.8	90	130	20	13.8	8.3	65	65
	8.8	90	130	20	19.0	13.3	65	65
	R-70	90	130	20	15.7	9.3	65	65
RG M 12 I	5.8	125	170	40	20.5	12.1	75	75
	8.8	125	170	40	23.8	19.3	75	75
	R-70	125	170	40	22.5	13.5	75	75
RG M 16 I	5.8	160	210	80	35.7	22.4	95	95
	8.8	160	210	80	35.7	35.8	95	95
	R-70	160	210	80	35.7	25.1	95	95
RG M 20 I	5.8	200	260	120	54.8	35.4	125	125
	8.8	200	260	120	54.8	42.9	125	125
	R-70	200	260	120	54.8	39.4	125	125

¹⁾ Design according to EN 1992-4:2018 (for static resp. quasi-static loads). The partial safety factors for material resistance as regulated in the ETA as well as a partial safety factor for load actions of $\gamma_L = 1.4$ are considered. As a single anchor counts e.g. an anchor with a spacing $s \geq 3 \times h_{ef}$ and an edge distance $c \geq 1.5 \times h_{ef}$. Accurate data see ETA.

²⁾ The specified loads are valid for anchorages in dry and damp concrete. For temperatures in the anchoring substrate up to 50 °C (resp. short term up to 80 °C). Drill hole cleaning as per specification in the ETA. The factor Ψ_{sus} for sustained load was taken into account with 1.0.

³⁾ Further steel grades, versions and technical data see ETA, e.g. for dry internal conditions, galvanised steel (gvz); for damp interiors and for outdoor use, stainless steel (R).

⁴⁾ In the case of combinations of tension and shear loads, bending moments with reduced or minimum spacing and edge distances (anchor groups), the design must be carried out in accordance with the provisions of the complete ETA and the provisions of the EN 1992-4:2018. We recommend using our anchor design software C-FIX.

Injection mortar FIS VL

The solid injection mortar for standard applications in cracked concrete and masonry



High-bay warehouses

3

Applications

- Cable trays
- Air conditioning units
- Consoles
- Gratings
- Satellite antennas

Advantages

- The FIS VL is approved for use in cracked concrete and masonry, and achieves a high load-bearing capacity in these conditions.
- The injection mortar, based on vinylester resin, allows for anchorings in water-filled drill holes (410 ml cartridges only), thus allowing for rapid progress.
- The temperature resistance of the FIS VL

injection mortar of -40 °C to $+120\text{ °C}$ allows for a solid load level even when subjected to high temperature demands, thus providing great flexibility.

- FIS VL HIGH SPEED has a significantly shorter curing time than FIS VL, thus also ensuring swift work progress even at low temperatures.

Certificates



ETA-10/0352, for cracked concrete

ETA-15/0263, for masonry

Fire resistance classification R120

ETA-15/0539, Post-installed rebar connections

Building materials

Approved for anchorings in:

- Concrete C20/25 to C50/60, cracked
- Hollow blocks made from lightweight concrete
- Vertically perforated brick
- Perforated sand-lime brick
- Solid sand-lime brick
- Solid brick
- Rebar connections
- Aerated concrete

Also suitable for:

- Concrete C12/15
- Hollow blocks made from concrete

Functioning

- The FIS VL is a 2-component injection mortar based on vinylester.
- Resin and hardener are stored in two separate chambers and are not mixed and activated until extrusion through the static mixer.
- The 410 ml coaxial cartridge can be easily used with the fischer FIS AC dispenser.
- Partially used cartridges can be reused, simply by changing the static mixer.
- Related accessories for use in concrete and masonry can be found on page 128.

For use with

Anchors & sleeves page

126



Dispenser page 189



Accessories page

194



Installation in concrete with FIS VL and FIS A / RG M

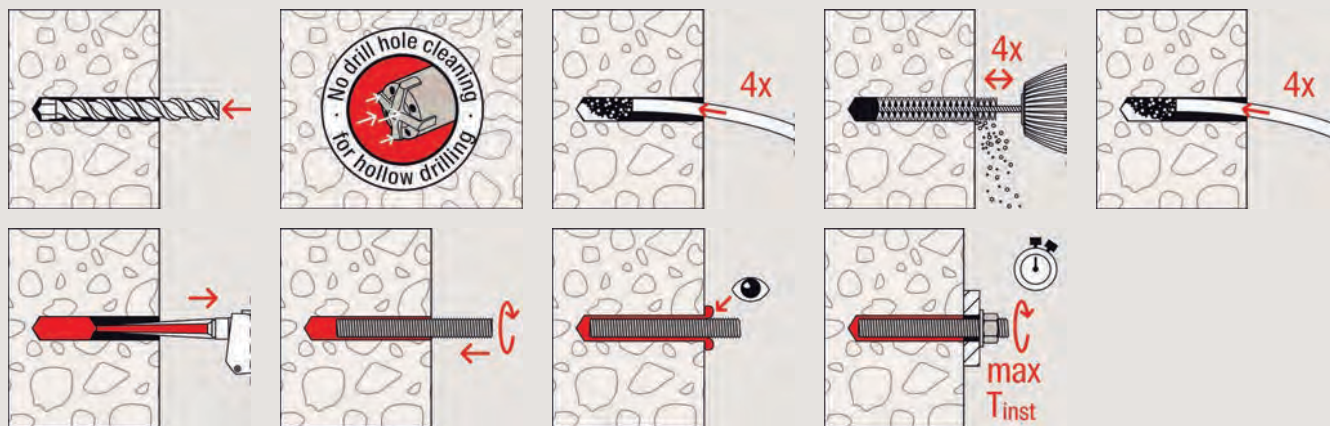

Installation in concrete with FIS VL and RG M I

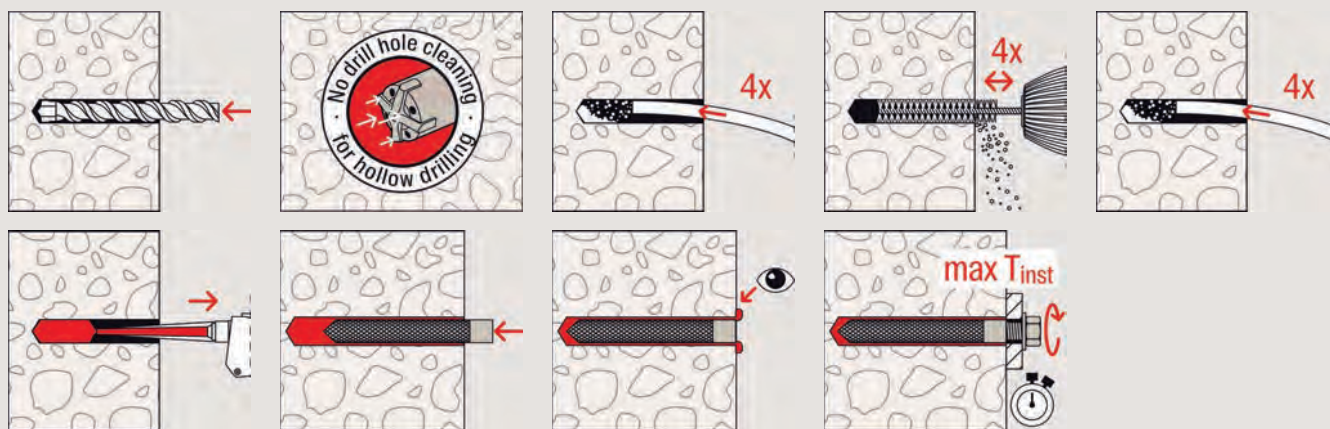

Installation in solid brick with FIS VL and FIS A / RG M

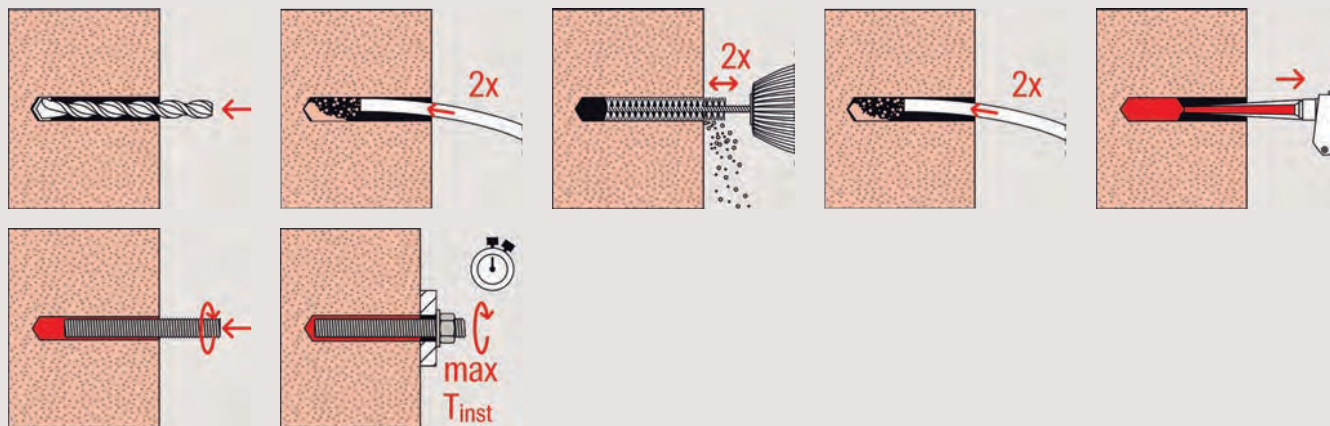

Installation in hollow blocks with FIS VL and FIS HK + FIS A / RG M

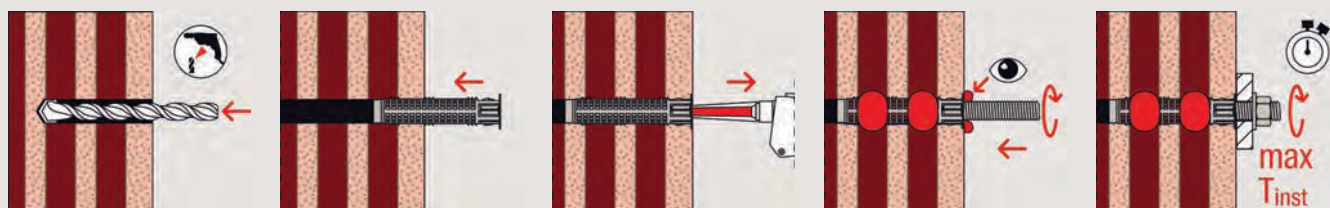

Installation in aerated concrete with FIS VL and FIS A / RG M

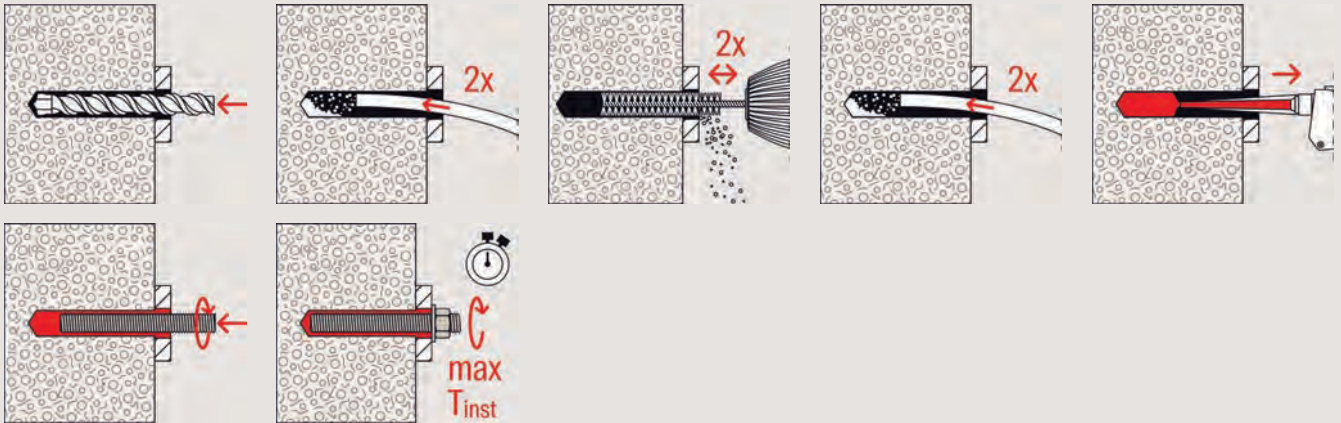

3

Technical data

Injection mortar FIS VL



Item	Item No.	Approval ETA	Languages on the cartridge	Scale unit	Contents	Sales unit [pcs]
FIS VL 300 T with clip	537149	●	PT, ES, EN	150	1 cartridge 300 ml, 2 x FIS MR Plus	12
FIS VL 300 T with clip	538583	●	CS, SK	150	1 cartridge 300 ml, 2 x FIS MR Plus	10
FIS VL 300 T HIGH SPEED with clip	538585	●	CS, SK	150	1 cartridge 380 ml, 2 x FIS MR Plus	10
FIS VL 300 T	539461	●	EN, FR, ES, PT, RO, AR	150	1 cartridge 300 ml, 2 x FIS MR Plus	12
FIS VL 300 T in bucket	539462	●	EN, FR, ES, PT, RO, AR	150	20 cartridges 300 ml, 40 x FIS MR Plus	1
FIS VL 300 T HWK big	538589	●	CS, SK	150	20 cartridges 300 ml, 40 x FIS MR Plus	1
FIS VL 360 S	558795	●	EN, AR	180	1 cartridge 360 ml, 2 x FIS MR plus	6
FIS VL 410 C	539463	●	EN, FR, ES, PT, RO, AR	200	1 cartridge 410 ml, 2 x FIS MR Plus	12
FIS VL 410 C	538584	●	CS, SK	200	1 cartridge 410 ml, 2 x FIS MR Plus	12
FIS VL 410 C HIGH SPEED	538586	●	CS, SK	200	1 cartridge 410 ml, 1 x FIS MR Plus	12
FIS VL 410 C in bucket	538549	●	DE, FR, NL, EN, TR	200	16 cartridges 410 ml, 32 x FIS MR Plus	1
FIS VL 410 C in bucket	539464	●	EN, FR, ES, PT, RO, AR	200	16 cartridges 410 ml, 32 x FIS MR Plus	1
FIS VL 410 C HWK big	538590	●	CS, SK	200	16 cartridges 410 ml, 32 x FIS MR Plus	1
FIS MR Plus	545853	—	—	—	10 static mixer FIS MR Plus	10

Curing times

FIS VL High Speed FIS VL						
Temperature at anchoring base [°C]	Maximum processing time t_{work}		Minimum curing time $t_{cure}^{1)}$			
	FIS VL High Speed [min.]	FIS VL [min.]	FIS VL High Speed [hrs.]	[min.]	FIS VL [hrs.]	[min.]
-10 - -5 ²⁾	—	—	12	—	—	—
> -5 - 0 ²⁾	5	—	3	—	24	—
> 0 - +5 ²⁾	5	13	3	—	3	—
> +5 - +10	3	9	—	50	—	90
> +10 - +20	1	5	—	30	—	60
> +20 - +30	—	4	—	—	—	45
> +30 - +40	—	2	—	—	—	35

1) In wet concrete or water filled holes the curing times must be doubled.

2) Minimal cartridge temperature +5 °C

Loads

Injection system FIS VL with threaded rod FIS A in solid and perforated masonry

Permissible loads^{1) 2)} for a single anchor in masonry for pre-positioned installation.
For the design the complete current assessment ETA-15/0263 has to be considered.

Type	Compressive brick strength f_b [N/mm ²]	Brick raw density ρ [kg/dm ³]	Minimum brick dimensions ³⁾ (L x B x H) [mm]	Effective anchor-age depth h_{ef} [mm]	Minimum member thickness h_{min} [mm]	Maximum installation torque $T_{inst,max}$ [Nm]	Permissible tensile load ⁴⁾ N_{perm} [kN]	Permissible shear load ⁴⁾ V_{perm} [kN]	Minimum-spacing ⁵⁾ $s_{min \parallel} / s_{min \perp}$ [mm]	Characteristic resp. minimum edge distance ⁵⁾ $c_{cr} = c_{min}$ [mm]
Solid sand-lime brick KS, acc. to EN 771-2										
M8	≥ 12	≥ 1.8	240 x 115 x 71	≥ 50	115	5	1.14	0.43	80 / 150	60
M8	≥ 12	≥ 1.8	240 x 115 x 71	100	240	5	2.29	0.86	80 / 300	60
M10	≥ 12	≥ 1.8	240 x 115 x 71	100	240	15	1.57	0.57	80 / 300	60
M10	≥ 12	≥ 1.8	240 x 115 x 71	200	240	15	3.43	0.57	80 / 600	60
M12	≥ 12	≥ 1.8	240 x 115 x 71	100	240	15	1.29	0.57	80 / 300	60
M12	≥ 12	≥ 1.8	240 x 115 x 71	200	240	15	3.43	0.57	80 / 300	60
Perforated sand-lime brick KSL, acc. to EN 771-2³⁾										
M8 with FIS H 12 x 85 K	≥ 12	≥ 1.4	240 x 175 x 113	85	175	2	0.71	0.71	100 / 115	60
M8 / M10 with FIS H 16 x 85 K	≥ 12	≥ 1.4	240 x 175 x 113	85	175	2	0.86	1.29	100 / 115	80
M12 with FIS H 20 x 85 K	≥ 12	≥ 1.4	240 x 175 x 113	85	175	2	0.86	1.29	100 / 115	80
M8 / M10 with FIS H 16 x 130 K	≥ 12	≥ 1.4	240 x 175 x 113	130	175	2	0.86	1.29	100 / 115	80
Vertically perforated brick Hz, acc. to EN 771-1³⁾										
M8 with FIS H 12 x 85 K	≥ 10	≥ 0.9	240 x 175 x 113	85	175	2	1.14	1.14	240 / 115	100
M8 / M10 with FIS H 16 x 85 K	≥ 10	≥ 0.9	240 x 175 x 113	85	175	2	1.00	1.57	240 / 115	100
M12 with FIS H 20 x 85 K	≥ 10	≥ 0.9	240 x 175 x 113	85	175	2	1.43	1.71	240 / 115	100
M8 / M10 with FIS H 16 x 130 K	≥ 10	≥ 0.9	240 x 175 x 113	130	175	2	1.43	1.57	240 / 115	100
M12 with FIS H 20 x 130 K	≥ 10	≥ 0.9	240 x 175 x 113	130	175	2	1.43	1.71	240 / 115	100
Aerated concrete acc. to EN 771-4⁶⁾										
M8	≥ 2	≥ 0.35	-	≥ 100	130	1	0.54	0.43	250 / 250	100
M8	≥ 4	≥ 0.50	-	200	230	8	1.07	0.71	80 / 80	100
M10	≥ 2	≥ 0.35	-	≥ 100	130	2	0.54	0.43	250 / 250	100
M10	≥ 4	≥ 0.50	-	200	230	12	1.79	0.71	80 / 80	100
M12	≥ 2	≥ 0.35	-	≥ 100	130	2	0.71	0.54	250 / 250	100
M12	≥ 4	≥ 0.50	-	200	230	16	1.79	0.71	80 / 80	100

¹⁾ The required partial safety factors for material resistance as well as a partial safety factor for load actions of $\gamma_L = 1.4$ are considered. Load values are valid for zinc-plated steel, stainless steel R and highly corrosion-resistant steel HCR. In perforated bricks and hollow blocks threaded rod FIS A in combination with anchor sleeve FIS H K.

²⁾ The given loads are valid for installation and use of fixations in dry masonry - use category d/d - for temperatures in the substrate up to 50 °C (resp. short term up to 80 °C) and drill hole cleaning according to assessment. The given brick types in combination with the permissible loads are an extract of the assessment.

³⁾ More information about, e.g. hole patterns, assortment of anchor sleeves FIS H K see assessment.

⁴⁾ In the case of combinations of tensile and shear loads, bending moments and reduced edge and axial spacings (anchor groups), the design must be carried out in accordance with the provisions of the complete assessment.

⁵⁾ Minimum feasible spacing resp. edge distance. Details as well as to the distances to joints see assessment.

⁶⁾ Cylindrical drill hole.

Loads

Injection system FIS VL with threaded rod FIS A resp. RG M

Permissible loads of a single anchor^{1) 2)} in normal concrete of strength class C20/25.
For the design the complete current assessment ETA-10/0352 has to be considered.

Type	Material / surface ³⁾	Effective anchorage depth h_{ef} [mm]	Minimum member thickness h_{min} [mm]	Maximum installation torque $T_{inst, max}$ [Nm]	Cracked concrete				Non-cracked concrete			
					Permissible tension (N_{perm}) and shear loads (V_{perm}); minimum spacing (s_{min}) and edge distances (c_{min}) with reduced loads				Permissible tension (N_{perm}) and shear loads (V_{perm}); minimum spacing (s_{min}) and edge distances (c_{min}) with reduced loads			
					$N_{perm}^{4)}$ [kN]	$V_{perm}^{4)}$ [kN]	$s_{min}^{4)}$ [mm]	$c_{min}^{4)}$ [mm]	$N_{perm}^{4)}$ [kN]	$V_{perm}^{4)}$ [kN]	$s_{min}^{4)}$ [mm]	$c_{min}^{4)}$ [mm]
FIS A M 8	5.8	60	100	10	-	-	-	-	6.6	6.3	40	40
	5.8	80	110	10	-	-	-	-	8.8	6.3	40	40
	5.8	160	190	10	-	-	-	-	9.0	6.3	40	40
	R-70	60	100	10	-	-	-	-	6.6	6.0	40	40
	R-70	80	110	10	-	-	-	-	8.8	6.0	40	40
	R-70	160	190	10	-	-	-	-	13.8	6.0	40	40
FIS A M 10	5.8	60	100	20	4.5	9.7	45	45	8.2	9.7	45	45
	5.8	90	120	20	6.7	9.7	45	45	12.3	9.7	45	45
	5.8	200	230	20	13.8	9.7	45	45	13.8	9.7	45	45
	R-70	60	100	20	4.5	9.2	45	45	8.2	9.2	45	45
	R-70	90	120	20	6.7	9.2	45	45	12.3	9.2	45	45
	R-70	200	230	20	15.0	9.2	45	45	15.7	9.2	45	45
FIS A M 12	5.8	70	100	40	6.3	14.3	55	55	11.4	14.3	55	55
	5.8	110	140	40	9.9	14.3	55	55	18.1	14.3	55	55
	5.8	240	270	40	20.5	14.3	55	55	20.5	14.3	55	55
	R-70	70	100	40	6.3	13.7	55	55	11.4	13.7	55	55
	R-70	110	140	40	9.9	13.7	55	55	18.1	13.7	55	55
	R-70	240	270	40	21.5	13.7	55	55	22.5	13.7	55	55
FIS A M 16	5.8	80	120	60	9.6	23.0	65	65	14.0	26.9	65	65
	5.8	125	170	60	15.0	26.9	65	65	24.9	26.9	65	65
	5.8	320	360	60	37.6	26.9	65	65	37.6	26.9	65	65
	R-70	80	120	60	9.6	23.0	65	65	14.0	25.2	65	65
	R-70	125	170	60	15.0	25.2	65	65	24.9	25.2	65	65
	R-70	320	360	60	38.3	25.2	65	65	42.0	25.2	65	65
FIS A M 20	5.8	90	140	120	11.7	28.0	85	85	16.7	40.0	85	85
	5.8	170	220	120	23.3	42.3	85	85	40.3	42.3	85	85
	5.8	400	450	120	54.9	42.3	85	85	58.6	42.3	85	85
	R-70	90	140	120	11.7	28.0	85	85	16.7	39.4	85	85
	R-70	170	220	120	23.3	39.4	85	85	40.3	39.4	85	85
	R-70	400	450	120	54.9	39.4	85	85	65.7	39.4	85	85
FIS A M 24	5.8	96	160	150	-	-	-	-	18.4	44.1	105	105
	5.8	210	270	150	-	-	-	-	56.5	60.6	105	105
	5.8	480	540	150	-	-	-	-	84.3	60.6	105	105
	R-70	96	160	150	-	-	-	-	18.4	44.1	105	105
	R-70	210	270	150	-	-	-	-	56.5	56.8	105	105
	R-70	480	540	150	-	-	-	-	94.3	56.8	105	105
FIS A M 30	5.8	120	190	300	-	-	-	-	25.7	61.6	140	140
	5.8	280	350	300	-	-	-	-	89.0	96.0	140	140
	5.8	600	670	300	-	-	-	-	133.8	96.0	140	140
	R-70	120	190	300	-	-	-	-	25.7	61.6	140	140
	R-70	280	350	300	-	-	-	-	89.0	90.2	140	140
	R-70	600	670	300	-	-	-	-	150.1	90.2	140	140

¹⁾ Design according to EN 1992-4:2018 (for static resp. quasi-static loads). The partial safety factors for material resistance as regulated in the ETA as well as a partial safety factor for load actions of $\gamma_L = 1.4$ are considered. As a single anchor counts e.g. an anchor with a spacing $s \geq 3 \times h_{ef}$ and an edge distance $c \geq 1.5 \times h_{ef}$. Accurate data see ETA.

²⁾ The specified loads are valid for anchorages in dry and damp concrete. For temperatures in the anchoring substrate up to 50 °C (resp. short term up to 80 °C). Drill hole cleaning as per specification in the ETA. The factor ψ_{sus} for sustained load was taken into account with 1.0.

³⁾ Further steel grades, versions and technical data see ETA, e.g. for dry internal conditions, galvanised steel (gvz); for damp interiors and for outdoor use, stainless steel (R).

⁴⁾ In the case of combinations of tension and shear loads, bending moments with reduced or minimum spacing and edge distances (anchor groups), the design must be carried out in accordance with the provisions of the complete ETA and the provisions of the EN 1992-4:2018. We recommend using our anchor design software C-FIX.

Loads

Injection system FIS VL with internal threaded anchor RG M I

Permissible loads of a single anchor^{1) 2)} in normal concrete of strength class C20/25.
For the design the complete current assessment ETA-10/0352 has to be considered.

Type	Screw Material ³⁾	Effective anchorage depth h_{ef} [mm]	Minimum member thickness h_{min} [mm]	Maximum Installation torque $T_{inst, max}$ [Nm]	Non-cracked concrete			
					Permissible tension (N_{perm}) and shear loads (V_{perm}); minimum spacing (s_{min}) and edge distances (c_{min}) with reduced loads			
					$N_{perm}^{4)}$ [kN]	$V_{perm}^{4)}$ [kN]	$s_{min}^{4)}$ [mm]	$c_{min}^{4)}$ [mm]
RG M 8 I	5.8	90	120	10	9.0	5.3	55	55
	8.8	90	120	10	13.8	8.3	55	55
	R-70	90	120	10	9.9	5.9	55	55
RG M 10 I	5.8	90	130	20	13.8	8.3	65	65
	8.8	90	130	20	16.7	13.3	65	65
	R-70	90	130	20	15.7	9.3	65	65
RG M 12 I	5.8	125	170	40	20.5	12.1	75	75
	8.8	125	170	40	26.6	19.3	75	75
	R-70	125	170	40	22.5	13.5	75	75
RG M 16 I	5.8	160	210	80	37.6	22.4	95	95
	8.8	160	210	80	39.5	30.9	95	95
	R-70	160	210	80	39.5	25.1	95	95
RG M 20 I	5.8	200	260	120	55.2	35.4	125	125
	8.8	200	260	120	55.2	42.9	125	125
	R-70	200	260	120	55.2	39.4	125	125

¹⁾ Design according to EN 1992-4:2018 (for static resp. quasi-static loads). The partial safety factors for material resistance as regulated in the ETA as well as a partial safety factor for load actions of $\gamma_L = 1.4$ are considered. As a single anchor counts e.g. an anchor with a spacing $s \geq 3 \times h_{ef}$ and an edge distance $c \geq 1.5 \times h_{ef}$. Accurate data see ETA.

²⁾ The specified loads are valid for anchorages in dry and damp concrete. For temperatures in the anchoring substrate up to 50 °C (resp. short term up to 80 °C). Drill hole cleaning as per specification in the ETA. The factor Ψ_{sus} for sustained load was taken into account with 1.0.

³⁾ Further steel grades, versions and technical data see ETA, e.g. for dry internal conditions, galvanised steel (gvz); for damp interiors and for outdoor use, stainless steel (R).

⁴⁾ In the case of combinations of tension and shear loads, bending moments with reduced or minimum spacing and edge distances (anchor groups), the design must be carried out in accordance with the provisions of the complete ETA and the provisions of the EN 1992-4:2018. We recommend using our anchor design software C-FIX.

Injection mortar FIS Green

The first approved injection mortar made with renewable raw materials



Building renovation



Bonding in interior construction

3

Applications

Injection mortar for use with:

- Threaded rods FIS A, see page 128
- Internal threaded anchor RG MI, see page 142
- Rebar anchor FRA, see page 170
- Concrete steel bars, see page 177
- Injection anchor sleeves FIS H, see page 149
- NSF certificate verifies its suitability for applications in drinking water

Certificates



ETA-14/0408, for non-cracked concrete

ETA-14/0471, for masonry



Fire resistance classification R120



Certified to NSF/ANSI 61



Advantages

- The worldwide first injection mortar with renewable raw materials. The share of renewable raw materials is certified by DIN CERTCO / TÜV Rheinland.
- Because of the European Technical Assessment it is possible to use the injection system in the area of public buildings.
- The low content of volatile organic compounds (VOC) has a positive effect for the evaluation of fixings in “GREEN Build-

ing”-projects.

- Biobased raw materials increase the residential and workplace quality and preserve valuable resources for future generations.
- The injection system is not mandatory for indication and thus reduces risks for installers and the environment.
- FIS GREEN is suitable for the use with the complete fischer injection accessories.

Building materials

Approved for anchorings in:

- Concrete C20/25 to C50/60, non-cracked
- Solid brick
- Vertically perforated brick
- Solid sand-lime brick
- Perforated sand-lime brick
- Aerated concrete

Functioning

- FIS GREEN is a 2-component injection mortar.
- Resin and hardener are stored in two separate chambers and are not mixed and activated until extrusion through the static mixer.
- The injection cartridges are quick and easy to use with the fischer dispensers.
- Partially used cartridges can be reused by changing the static mixer.
- Related accessories for the various applications can be found on pages “non-cracked concrete” and “masonry”.

For use with

Anchors & sleeves page

126



Dispenser page 189



Accessories page

194



Installation in concrete with FIS Green and FIS A / RG M

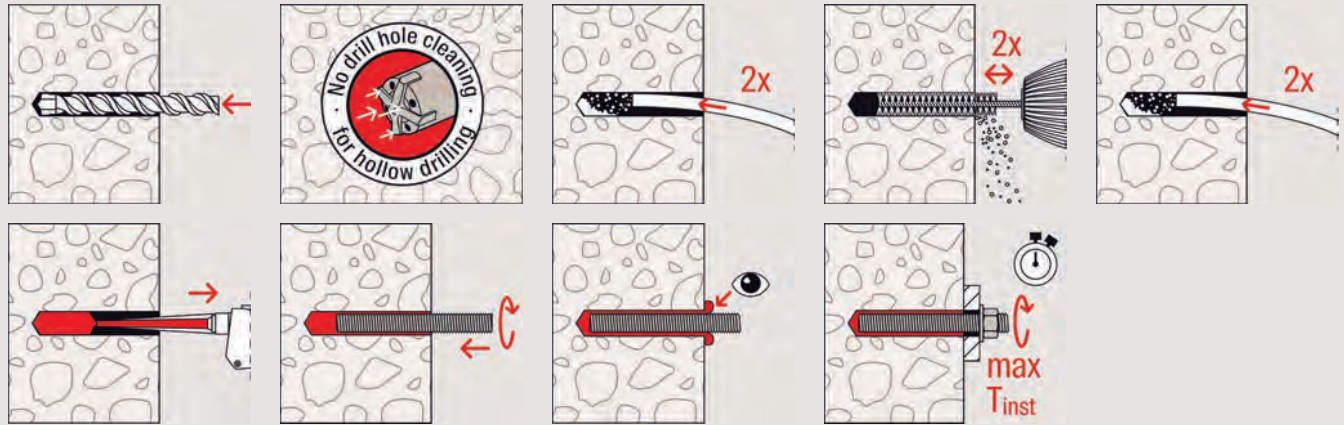

Installation in concrete with FIS Green and RG M I

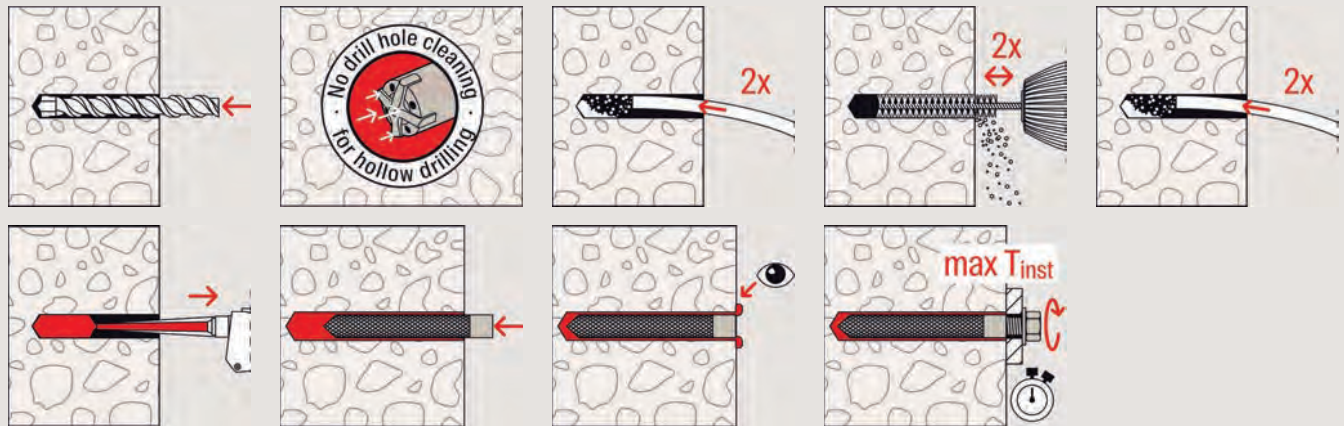

Installation in solid brick with FIS Green and FIS A / RG M

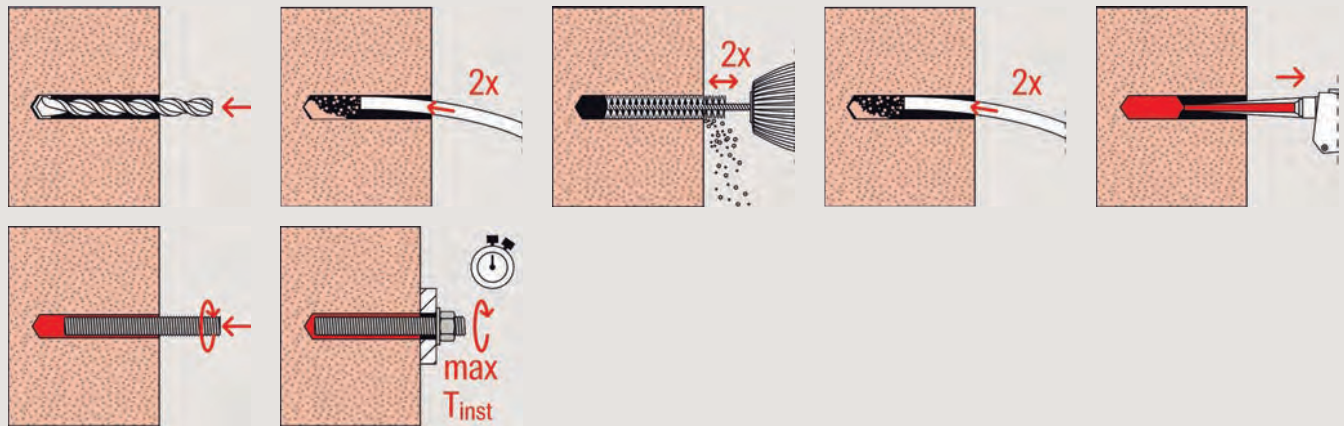

Installation in hollow blocks with FIS Green and FIS HK + FIS A / RG M

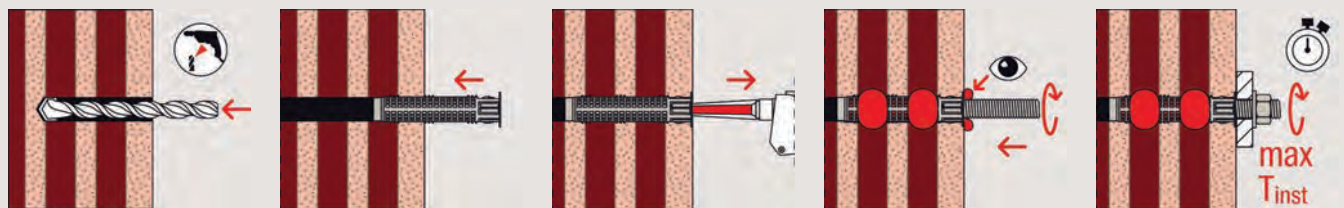

Installation in aerated concrete with FIS Green and FIS A / RG M

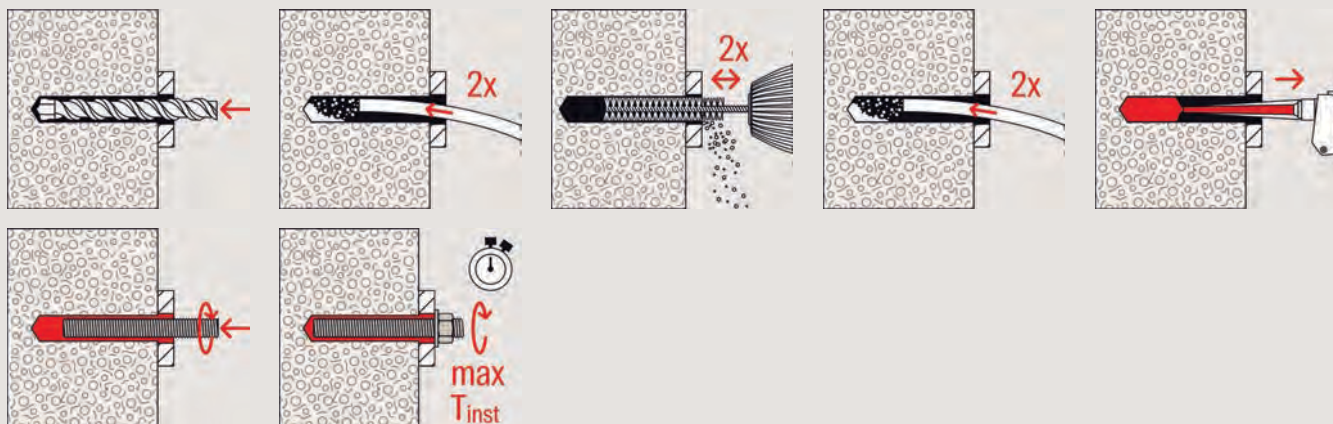

3

Technical data

Injection mortar FIS Green



FIS Green 300 T

FIS MR Plus

Item	Item No.	Approval ETA	Languages on the cartridge	Scale unit	Contents	Sales unit [pcs]
FIS Green 300 T	522223	●	DE	150	1 cartridge 300 ml, 2 x FIS MR Plus	12
FIS Green 300 T K	523244	●	DE	150	1 cartridge 300 ml, 2 x FIS MR Plus (incl. clip with europerforation)	4
FIS Green 300 T	522989	●	FR	150	1 cartridge 300 ml, 2 x FIS MR Plus with transparent Clip	4
FIS Green 300 T	523245	●	IT	150	1 cartridge 300 ml, 2 x FIS MR Plus with transparent Clip	12
FIS Green 300 T	538219	●	CS, SK	150	1 cartridge 300 ml, 2 x FIS MR Plus	12
FIS Green 300 T	532972	●	DA, SV, NO, FI	150	1 cartridge 300 ml, 2 x FIS MR Plus with transparent Clip	12
FIS MR Plus	545853	—	—	—	10 static mixer FIS MR Plus	10

Curing times

FIS Green Cartridge temperature (mortar) [°C]	Maximum processing time t_{work} [min.]	Temperature at anchoring base [°C]	Minimum curing time ¹⁾	
			t_{cure} [hrs.]	[min.]
+5	13	±0 – +5	6	–
+10	9	> +5 – +10	4	–
+20	5	> +10 – +20	–	90
+30	4	> +20 – +30	–	60
+40	2	> +30 – +40	–	30

1) In damp concrete and water-filled holes, the curing time is to be doubled.

Loads

Injection system FIS Green with threaded rod FIS A in solid and perforated masonry

Permissible loads^{1) 2)} for a single anchor in masonry for pre-positioned installation.
For the design the complete current assessment ETA-14/0471 has to be considered.

Type	Compressive brick strength f_b [N/mm ²]	Brick raw density ρ [kg/dm ³]	Minimum brick dimensions ³⁾ (L x W x H) [mm]	Effective anchorage depth h_{ef} [mm]	Minimum member thickness h_{min} [mm]	Maximum installation torque $T_{inst,max}$ [Nm]	Permissible tensile load ⁴⁾ N_{perm} [kN]	Permissible shear load ⁴⁾ V_{perm} [kN]	Minimum spacing ⁵⁾ $s_{min} \parallel$ / $s_{min} \perp$ [mm]	Characteristic resp. minimum edge distance ⁶⁾ $c_{cr} = c_{min}$ [mm]
Solid brick Mz, NF, acc. to EN 771-1										
M6	≥ 10	≥ 1.8	240 x 115 x 71	≥ 50	115	4	0.43	0.71	150 / 150	100
M8	≥ 10	≥ 1.8	240 x 115 x 71	≥ 50	115	10	0.71	0.71	150 / 150	100
M10	≥ 10	≥ 1.8	240 x 115 x 71	80	115	10	1.29	1.14	240 / 240	100
M10	≥ 10	≥ 1.8	240 x 115 x 71	200	240	10	3.14	2.43	300 / 300	100
M12	≥ 10	≥ 1.8	240 x 115 x 71	80	115	10	1.43	1.14	240 / 240	100
M12	≥ 10	≥ 1.8	240 x 115 x 71	200	240	10	2.00	3.29	300 / 300	100
Solid sand-lime brick KS, acc. to EN 771-2										
M6	≥ 10	≥ 1.8	240 x 115 x 71	50	115	4	0.43	0.86	150 / 150	100
M8	≥ 10	≥ 1.8	240 x 115 x 71	50	115	10	0.71	1.14	150 / 150	100
M10	≥ 10	≥ 1.8	240 x 115 x 71	80	115	10	0.86	1.14	240 / 240	100
M10	≥ 10	≥ 1.8	240 x 115 x 71	200	240	10	2.57	1.14	300 / 300	100
M12	≥ 10	≥ 1.8	240 x 115 x 71	80	115	10	0.86	1.43	240 / 240	100
M12	≥ 10	≥ 1.8	240 x 115 x 71	200	240	10	2.57	1.43	300 / 300	100
Perforated sand-lime brick KSL, acc. to EN 771-2³⁾										
M6 / M8 with FIS H 12 x 85 K	≥ 12	≥ 1.4	240 x 175 x 113	85	175	2	0.34	0.71	240 / 115	100
M8 / M10 with FIS H 16 x 85 K	≥ 12	≥ 1.4	240 x 175 x 113	85	175	4	0.57	1.57	240 / 115	100
M12 / M16 with FIS H 20 x 85 K	≥ 12	≥ 1.4	240 x 175 x 113	85	175	4	0.57	1.29	240 / 115	100
M8 / M10 with FIS H 16 x 130 K	≥ 12	≥ 1.4	240 x 175 x 113	130	175	4	0.57	1.57	240 / 115	100
M12 / M16 with FIS H 20 x 130 K	≥ 12	≥ 1.4	240 x 175 x 113	130	175	4	0.43	1.29	240 / 115	100
Vertically perforated brick Hlz, acc. to EN 771-1³⁾										
M6 / M8 with FIS H 12 x 85 K	≥ 10	≥ 1.0	240 x 175 x 113	85	175	2	0.57	1.14	240 / 115	120
M8 / M10 with FIS H 16 x 85 K	≥ 10	≥ 1.0	240 x 175 x 113	85	175	4	0.57	1.57	240 / 115	120
M12 / M16 with FIS H 20 x 85 K	≥ 10	≥ 1.0	240 x 175 x 113	85	175	5	0.71	1.71	240 / 115	120
M8 / M10 with FIS H 16 x 130 K	≥ 10	≥ 1.0	240 x 175 x 113	130	175	4	0.71	1.57	240 / 115	120
M12 / M16 with FIS H 20 x 130 K	≥ 10	≥ 1.0	240 x 175 x 113	130	175	4	0.57	1.71	240 / 115	120
Aerated concrete acc. to EN 771-4⁶⁾										
M6	≥ 2	≥ 0.35	-	≥ 100	130	1	0.54	0.32	240 / 115	80
M6	≥ 4	≥ 0.50	-	≥ 100	130	1	0.71	0.54	240 / 115	80
M8	≥ 2	≥ 0.35	-	≥ 100	130	2	0.71	0.32	240 / 115	80
M8	≥ 4	≥ 0.50	-	≥ 100	130	2	0.89	0.54	240 / 115	80
M10	≥ 2	≥ 0.35	-	≥ 100	130	4	0.71	0.32	240 / 115	80
M10	≥ 4	≥ 0.50	-	≥ 100	130	4	1.07	0.54	240 / 115	80
M12	≥ 2	≥ 0.35	-	≥ 100	130	4	0.89	0.32	240 / 115	80
M12	≥ 4	≥ 0.50	-	≥ 100	130	4	1.07	0.54	240 / 115	80
M16	≥ 2	≥ 0.35	-	≥ 100	130	4	0.89	0.43	240 / 115	80
M16	≥ 4	≥ 0.50	-	≥ 100	130	4	1.07	0.54	240 / 115	80

¹⁾ The required partial safety factors for material resistance as well as a partial safety factor for load actions of $\gamma_L = 1.4$ are considered. Load values are valid for zinc-plated steel, stainless steel R and highly corrosion-resistant steel HCR. In perforated bricks and hollow blocks threaded rod FIS A in combination with anchor sleeve FIS H K.

²⁾ The given loads are valid for installation and use of fixations in dry masonry - use category d/d - for temperatures in the substrate up to 50 °C (resp. short term up to 80 °C) and drill hole cleaning according to assessment. The given brick types in combination with the permissible loads are an extract of the assessment.

³⁾ More information about, e.g. hole patterns, assortment of anchor sleeves FIS H K see assessment.

⁴⁾ In the case of combinations of tensile and shear loads, bending moments and reduced edge and axial spacings (anchor groups), the design must be carried out in accordance with the provisions of the complete assessment.

⁵⁾ Minimum feasible spacing resp. edge distance. Details as well as to the distances to joints see assessment.

⁶⁾ Cylindrical drill hole.

Loads

Injection system FIS Green with threaded rod FIS A resp. RG M

Permissible loads of a single anchor^{1) 2)} in normal concrete of strength class C20/25.
For the design the complete current assessment ETA-14/0408 has to be considered.

Type	Material / surface ³⁾	Effective anchorage depth h_{ef} [mm]	Minimum member thickness h_{min} [mm]	Maximum Installation torque $T_{inst, max}$ [Nm]	Non-cracked concrete			
					Permissible tension (N_{perm}) and shear loads (V_{perm}); minimum spacing (s_{min}) and edge distances (c_{min}) with reduced loads			
					N_{perm} ⁴⁾ [kN]	V_{perm} ⁴⁾ [kN]	s_{min} ⁴⁾ [mm]	c_{min} ⁴⁾ [mm]
FIS A M 8	5.8	60	100	10	5.7	6.3	40	40
	5.8	80	110	10	7.6	6.3	40	40
	5.8	160	190	10	9.0	6.3	40	40
	R-70	60	100	10	5.7	6.0	40	40
	R-70	80	110	10	7.6	6.0	40	40
	R-70	160	190	10	9.9	6.0	40	40
FIS A M 10	5.8	60	100	20	6.7	9.7	45	45
	5.8	90	120	20	10.1	9.7	45	45
	5.8	200	230	20	13.8	9.7	45	45
	R-70	60	100	20	6.7	9.2	45	45
	R-70	90	120	20	10.1	9.2	45	45
	R-70	200	230	20	15.7	9.2	45	45
FIS A M 12	5.8	70	100	40	8.9	14.3	55	55
	5.8	110	140	40	14.0	14.3	55	55
	5.8	240	270	40	20.5	14.3	55	55
	R-70	70	100	40	8.9	13.7	55	55
	R-70	110	140	40	14.0	13.7	55	55
	R-70	240	270	40	22.5	13.7	55	55
FIS A M 16	5.8	80	120	60	12.0	26.9	65	65
	5.8	125	170	60	18.7	26.9	65	65
	5.8	320	360	60	37.6	26.9	65	65
	R-70	80	120	60	12.0	25.2	65	65
	R-70	125	170	60	18.7	25.2	65	65
	R-70	320	360	60	42.0	25.2	65	65
FIS A M 20	5.8	90	140	120	14.6	35.0	85	85
	5.8	170	220	120	27.6	42.3	85	85
	5.8	400	450	120	58.6	42.3	85	85
	R-70	90	140	120	14.6	35.0	85	85
	R-70	170	220	120	27.6	39.4	85	85
	R-70	400	450	120	64.8	39.4	85	85

¹⁾ Design according to EN 1992-4:2018 (for static resp. quasi-static loads). The partial safety factors for material resistance as regulated in the ETA as well as a partial safety factor for load actions of $\gamma_L = 1.4$ are considered. As a single anchor counts e.g. an anchor with a spacing $s \geq 3 \times h_{ef}$ and an edge distance $c \geq 1.5 \times h_{ef}$. Accurate data see ETA.

²⁾ The specified loads are valid for anchorages in dry and damp concrete. For temperatures in the anchoring substrate up to 50 °C (resp. short term up to 80 °C). Drill hole cleaning as per specification in the ETA. The factor Ψ_{sus} for sustained load was taken into account with 1.0.

³⁾ Further steel grades, versions and technical data see ETA, e.g. for dry internal conditions, galvanised steel (gvz); for damp interiors and for outdoor use, stainless steel (R).

⁴⁾ In the case of combinations of tension and shear loads, bending moments with reduced or minimum spacing and edge distances (anchor groups), the design must be carried out in accordance with the provisions of the complete ETA and the provisions of the EN 1992-4:2018. We recommend using our anchor design software C-FIX.

Loads

Injection system FIS Green with internal threaded anchor RG M I

Permissible loads of a single anchor^{1) 2)} in normal concrete of strength class C20/25.
For the design the complete current assessment ETA-14/0408 has to be considered.

Type	Screw Material ³⁾	Effective anchorage depth h_{ef} [mm]	Minimum member thickness h_{min} [mm]	Maximum Installation torque $T_{inst, max}$ [Nm]	Non-cracked concrete			
					Permissible tension (N_{perm}) and shear loads (V_{perm}); minimum spacing (s_{min}) and edge distances (c_{min}) with reduced loads			
					$N_{perm}^{4)}$ [kN]	$V_{perm}^{4)}$ [kN]	$s_{min}^{4)}$ [mm]	$c_{min}^{4)}$ [mm]
RG M 8 I	5.8	90	120	10	9.0	5.3	55	55
	8.8	90	120	10	11.9	8.3	55	55
	R-70	90	120	10	9.9	5.9	55	55
RG M 10 I	5.8	90	130	20	13.8	8.3	65	65
	8.8	90	130	20	13.9	13.3	65	65
	R-70	90	130	20	13.9	9.3	65	65
RG M 12 I	5.8	125	170	40	20.2	12.1	75	75
	8.8	125	170	40	20.2	19.3	75	75
	R-70	125	170	40	20.2	13.5	75	75
RG M 16 I	5.8	160	210	80	27.8	22.4	95	95
	8.8	160	210	80	27.8	30.9	95	95
	R-70	160	210	80	27.8	25.1	95	95

¹⁾ Design according to EN 1992-4:2018 (for static resp. quasi-static loads). The partial safety factors for material resistance as regulated in the ETA as well as a partial safety factor for load actions of $\gamma_L = 1.4$ are considered. As a single anchor counts e.g. an anchor with a spacing $s \geq 3 \times h_{ef}$ and an edge distance $c \geq 1.5 \times h_{ef}$. Accurate data see ETA.

²⁾ The specified loads are valid for anchorages in dry and damp concrete. For temperatures in the anchoring substrate up to 50 °C (resp. short term up to 80 °C). Drill hole cleaning as per specification in the ETA. The factor Ψ_{sus} for sustained load was taken into account with 1.0.

³⁾ Further steel grades, versions and technical data see ETA, e.g. for dry internal conditions, galvanised steel (gvz); for damp interiors and for outdoor use, stainless steel (R).

⁴⁾ In the case of combinations of tension and shear loads, bending moments with reduced or minimum spacing and edge distances (anchor groups), the design must be carried out in accordance with the provisions of the complete ETA and the provisions of the EN 1992-4:2018. We recommend using our anchor design software C-FIX.

Injection mortar FIS P Plus

The approved injection mortar for anchorings in masonry and non-cracked concrete



Cable duct



Air conditioning units

3

Applications

Injection mortar for use in masonry and non-cracked concrete with:

- Threaded rods FIS A, see pages 128
- Injection anchor sleeves FIS H K, see page 149
- Injection push-through anchor sleeve FIS H K, see page 149

Assessment/Approval



ETA-11/0419, for masonry

ETA-18/0383, for non-cracked concrete

Advantages

- With FIS P Plus, anchorings in masonry and non-cracked concrete for which approval is relevant can be realised in a particularly economical manner.
- FIS P Plus 300 T can be used with stable,

standard silicone injection dispensers. No special equipment is required. As a result, procurement costs can be reduced on the basis of polyester resin.

Building materials

- Concrete C20/25 to C50/60, non-cracked
 - Vertically perforated brick
 - Perforated sand-lime brick
 - Solid sand-lime brick
 - Perforated blocks made from lightweight concrete
 - Solid brick
 - Aerated concrete
- Also suitable for:
- Solid brick made from lightweight concrete

Functioning

- FIS P Plus is a 2-component injection mortar based on polyester resin.
- Resin and hardener are stored in two separate chambers and are not mixed and activated until extrusion through the static mixer.
- Partially used cartridges can be reused, simply by changing the static mixer.
- Related accessories for use in masonry and non-cracked concrete can be found on page 128.

For use with

Anchors & sleeves page

126



Dispenser page 189



Accessories page

194



Installation in concrete with FIS P Plus and FIS A / RG M

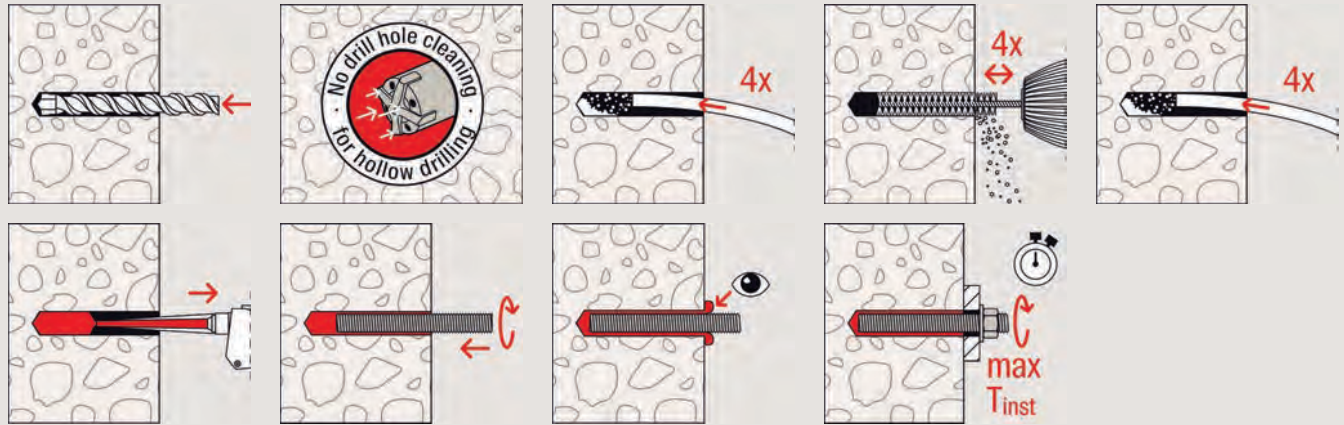

Installation in solid brick with FIS P Plus and FIS A / RG M

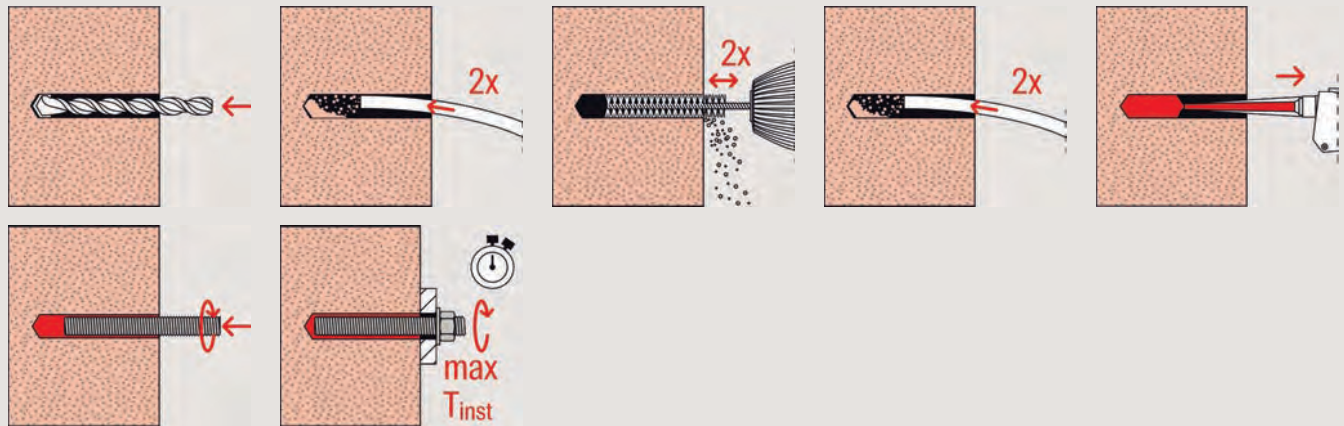

Installation in hollow blocks with FIS P Plus and FIS HK + FIS A / RG M

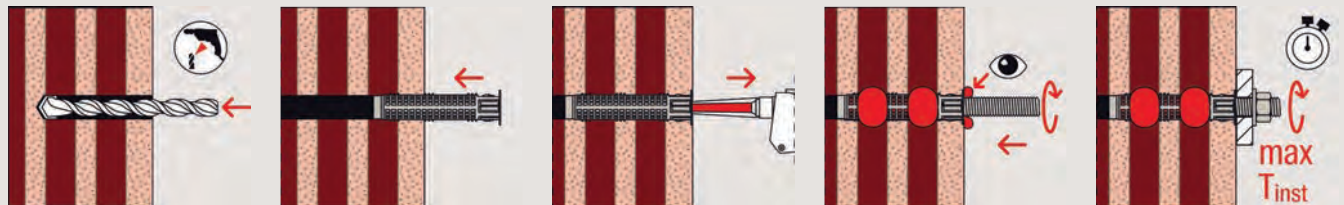

Installation in aerated concrete with FIS P Plus and FIS A / RG M

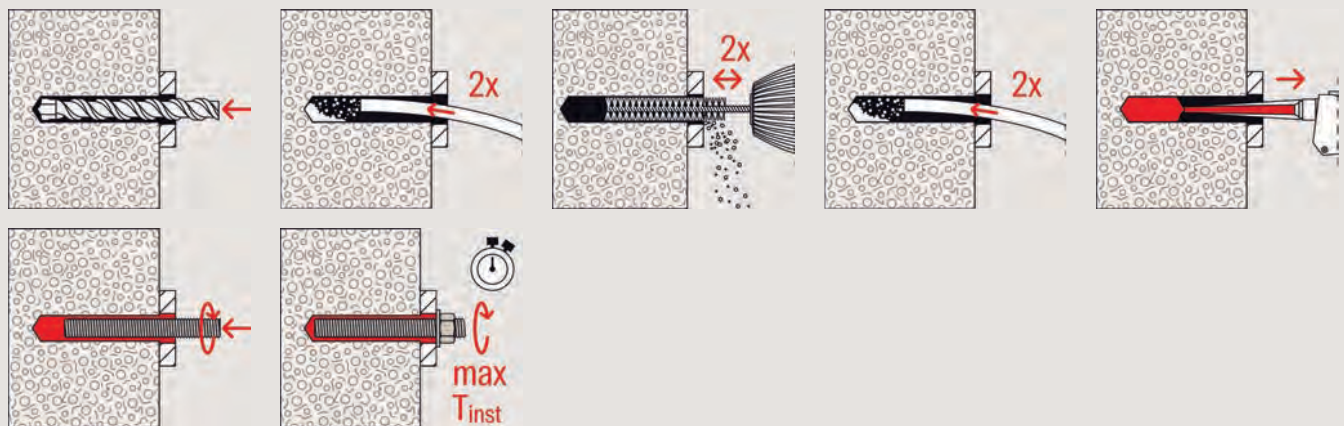

Technical data

Injection mortar FIS P Plus



FIS P Plus 300 T

FIS P Plus 380 C

FIS MR Plus

Item	Item No.	Approval ETA	Languages on the cartridge	Scale unit	Contents	Sales unit [pcs]
FIS P Plus 300 T	523226	●	EN, ES, PT	150	1 cartridge 300 ml, 1 x FIS MR Plus	12
FIS P Plus 300 T	537551	●	CS, SK, EL	150	1 cartridge 300 ml, 2 x FIS MR Plus	10
FIS P Plus 300 T	522430	●	DE, FR, NL	150	1 cartridge 300 ml, 2 x FIS MR Plus	12
FIS P Plus 300 T DIY	510637	●	ES, PT	150	1 cartridge 300 ml, 2 x FIS MR Plus	10
FIS P Plus 380 C	522178	●	EN, ES, PT	190	1 cartridge 380 ml, 2 x FIS MR Plus	12
FIS MR Plus	545853	—	—	—	10 static mixer FIS MR Plus	10

Technical data

Injection mortar FIS P Plus



FIS P PLUS 300 T HWK

Item	Item No.	Approval ETA	Languages on the cartridge	Contents	Sales unit [pcs]
FIS P PLUS 300 T HWK	551940	●	DE, FR, NL	12 cartridge 300ml, 24 x FIS MR Plus	1

Curing times

FIS P Plus Temperature at anchoring base [°C]	Maximum processing time t_{work} [min.]	Minimum curing time ¹⁾	
		t_{cure} [hrs.]	[min.]
> 0 – +5	13	3	–
> +5 – +10	9	–	90
> -10 – +20	5	–	60
> +20 – +30	4	–	45
> +30 – +40	2	–	35

1) In wet concrete or water filled holes the curing times must be doubled.

Loads

Injection system FIS P Plus with threaded rod FIS A resp. RG M

Permissible loads of a single anchor^{1) 2)} in normal concrete of strength class C20/25.
For the design the complete current assessment ETA-18/0383 has to be considered.

Type	Material / surface ³⁾	Effective anchorage depth h_{ef} [mm]	Minimum member thickness h_{min} [mm]	Maximum installation torque $T_{inst, max}$ [Nm]	Non-cracked concrete			
					Permissible tension (N_{perm}) and shear loads (V_{perm}); minimum spacing (s_{min}) and edge distances (c_{min}) with reduced loads			
					$N_{perm}^{4)}$ [kN]	$V_{perm}^{4)}$ [kN]	$s_{min}^{4)}$ [mm]	$c_{min}^{4)}$ [mm]
FIS A M 8	5.8	60	100	10	3.9	5.1	40	40
	5.8	80	110	10	5.2	5.1	40	40
	5.8	160	190	10	9.0	5.1	40	40
	R-70	60	100	10	3.9	6	40	40
	R-70	80	110	10	5.2	6	40	40
	R-70	160	190	10	9.9	6	40	40
FIS A M 10	5.8	60	100	20	4.9	8.6	45	45
	5.8	90	120	20	7.3	8.6	45	45
	5.8	200	230	20	13.8	8.6	45	45
	R-70	60	100	20	4.9	9.2	45	45
	R-70	90	120	20	7.3	9.2	45	45
	R-70	200	230	20	15.7	9.2	45	45
FIS A M 12	5.8	70	100	40	6.8	12.0	55	55
	5.8	110	140	40	10.7	12.0	55	55
	5.8	240	270	40	20.5	12.0	55	55
	R-70	70	100	40	6.8	13.7	55	55
	R-70	110	140	40	10.7	13.7	55	55
	R-70	240	270	40	22.5	13.7	55	55
FIS A M 16	5.8	80	120	60	10.4	22.3	65	65
	5.8	125	170	60	16.2	22.3	65	65
	5.8	320	360	60	37.6	22.3	65	65
	R-70	80	120	60	10.4	24.9	65	65
	R-70	125	170	60	16.2	25.2	65	65
	R-70	320	360	60	41.5	25.2	65	65
FIS A M 20	5.8	90	140	120	13.5	32.3	85	85
	5.8	170	220	120	25.4	34.9	85	85
	5.8	400	450	120	58.6	34.9	85	85
	R-70	90	140	120	13.5	32.3	85	85
	R-70	170	220	120	25.4	39.4	85	85
	R-70	400	450	120	59.8	39.4	85	85
FIS A M 24	5.8	96	160	150	17.2	41.4	105	105
	5.8	210	270	150	37.7	50.9	105	105
	5.8	480	540	150	84.3	50.9	105	105
	R-70	96	160	150	17.2	41.4	105	105
	R-70	210	270	150	37.7	56.8	105	105
	R-70	480	540	150	86.2	56.8	105	105

¹⁾ Design according to EN 1992-4:2018 (for static resp. quasi-static loads). The partial safety factors for material resistance as regulated in the ETA as well as a partial safety factor for load actions of $\gamma_L = 1.4$ are considered. As a single anchor counts e.g. an anchor with a spacing $s \geq 3 \times h_{ef}$ and an edge distance $c \geq 1.5 \times h_{ef}$. Accurate data see ETA.

²⁾ The specified loads are valid for anchorages in dry and damp concrete. For temperatures in the anchoring substrate up to 50 °C (resp. short term up to 80 °C). Drill hole cleaning as per specification in the ETA. The factor Ψ_{SUS} for sustained load was taken into account with 1.0.

³⁾ Further steel grades, versions and technical data see ETA, e.g. for dry internal conditions, galvanised steel (gvz); for damp interiors and for outdoor use, stainless steel (R).

⁴⁾ In the case of combinations of tension and shear loads, bending moments with reduced or minimum spacing and edge distances (anchor groups), the design must be carried out in accordance with the provisions of the complete ETA and the provisions of the EN 1992-4:2018. We recommend using our anchor design software C-FIX.

Injection mortar FIS P

The reliable injection mortar for anchorings in masonry



Gates



Wall consoles

3

Applications

Injection mortar for use in masonry and aerated concrete with:

- Threaded rods FIS A, see page 128
- Internal threaded anchor FIS E, see page 144
- Injection anchor sleeves FIS H, see page 149
- Aerated concrete centring sleeve PBZ, see page 195

Advantages

- The FIS P is the economical solution for anchorings in masonry that do not require approvals.
- The FIS P 300 T can be used with stable,

standard silicone injection dispensers. No special equipment is required. This helps to reduce procurement costs.

Building materials

- Vertically perforated brick
- Hollow block
- Perforated sand-lime brick
- Solid sand-lime brick
- Aerated concrete
- Solid brick made from lightweight concrete
- Solid brick

Functioning

- The FIS P is a 2-component injection mortar based on polyester resin.
- Resin and hardener are stored in two separate chambers and are not mixed and activated until extrusion through the static mixer.
- Partially used cartridges can be reused, simply by changing the static mixer.
- Related accessories for use in masonry and aerated concrete can be found on page 149 or page 194.

For use with

Anchors & sleeves page 126



Dispenser page 189



Accessories page 194



Installation in solid brick with FIS P and FIS A / RG M

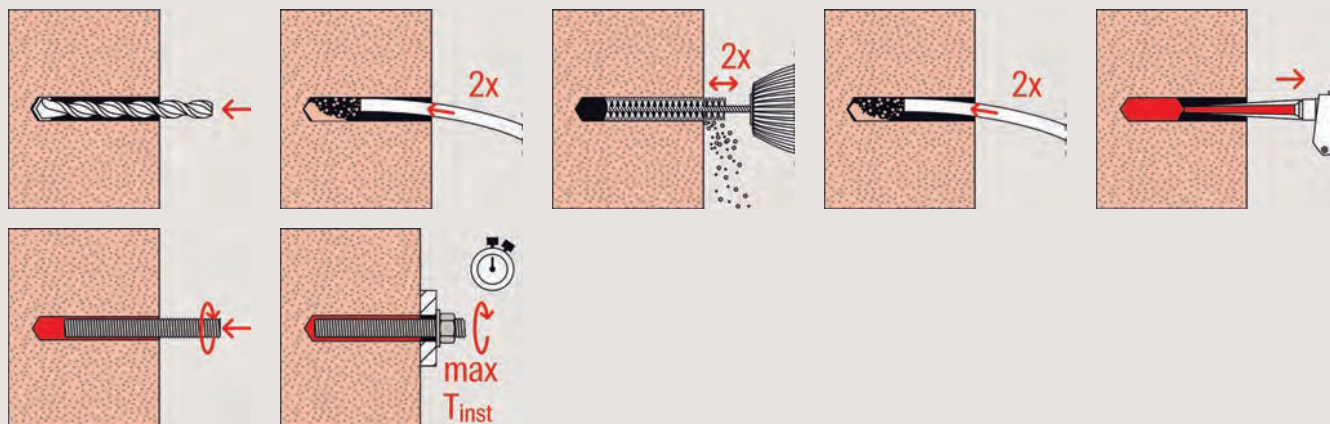

3

Installation in hollow blocks with FIS P and FIS HK + FIS A / RG M

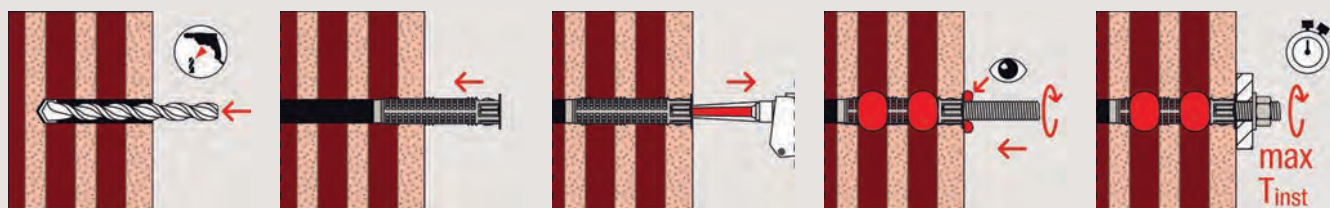

Installation in aerated concrete with FIS P and FIS A / RG M

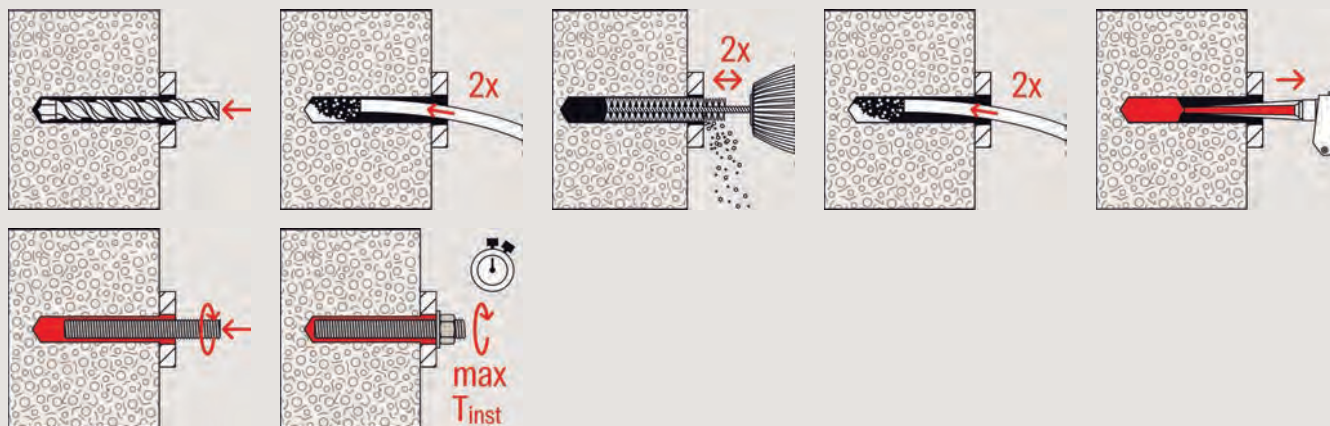

Technical data

Injection mortar FIS P



FIS P 300 T

FIS P 360 S

FIS P 380 C

FIS P 410 C

FIS MR Plus

Item	Item No.	Languages on the cartridge	Scale unit	Contents	Sales unit [pcs]
FIS P 300 T	093175	DE, EN, NL, ES, ZH, PT	150	1 cartridge 300 ml, 2 x FIS MR Plus	12
FIS P 300 T	093178	PL, SL, HU, HR, RO	150	1 cartridge 300 ml, 2 x FIS MR Plus	12
FIS P 300 T	502287	LT, LV, ET, UK, RU, KK	150	1 cartridge 300 ml, 2 x FIS MR Plus	12
FIS P 300 T	051061	CS, SK, EL	150	1 cartridge 300 ml, 2 x FIS MR Plus	12
FIS P 300 T	535861	USA, RA, BR, MEX	150	1 cartridge 300 ml, 2 x FIS MR Plus	12
FIS P 300 T with Clip	537150	USA, RA, BR, MEX	150	1 cartridge 300 ml, 2 x FIS MR Plus	10

Technical data

Injection mortar FIS P



Item	Item No.	Languages on the cartridge	Scale unit	Contents	Sales unit [pcs]
FIS P 300 T					
FIS P 360 S	558801	DE, FR, NL	180	1 cartridge 360 ml, 2 x FIS MR Plus	6
FIS P 360 S	558802	PL, RU, HR	180	1 cartridge 360 ml, 2 x FIS MR Plus	6
FIS P 360 S	558803	KO, ES, PT	180	1 cartridge 360 ml, 2 x FIS MR Plus	6
FIS P 360 S	558804	EN, ES, PT	180	1 cartridge 360 ml, 2 x FIS MR Plus	6
FIS P 380 C	059234	EN, RU	190	1 cartridge 380 ml, 2 x FIS MR Plus	12
FIS P 410 C	538134	USA, RA, BR, MEX	205	1 cartridge 410 ml, 2 x FIS MR Plus	12
FIS MR Plus	545853	—	—	10 static mixer FIS MR Plus	10

Technical data

Injection mortar FIS P













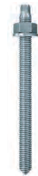







Item	Item No.	Languages on the cartridge	Contents	Sales unit [pcs]
FIS P 300 T HWK small				
FIS P 300 T in bucket	040040	DE, EN, NL, ES, ZH, PT	12 cartridges, 24 x FIS MR Plus	1
FIS P 300 T in bucket	511341	DE, EN, NL, ES, ZH, PT	20 cartridges, 20 x FIS MR Plus	1
FIS P 380 C in bucket	511340	EN, RU	16 cartridges, 16 x FIS MR Plus	1







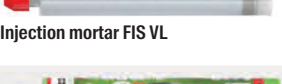

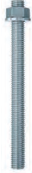
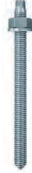

Curing times

FIS P Cartridge temperature (mortar) [°C]	Maximum processing time t_{work} [min.]	Temperature at anchoring base [°C]	Minimum curing time	
			t_{cure} [hrs.]	[min.]
		0 – +5	6	–
+5 – +10	15	+5 – +10	3	–
+10 – +20	8	+10 – +20	2	–
+20 – +30	5	+20 – +30	–	60
+30 – +40	3	+30 – +40	–	30

The above times apply from the moment of contact between resin and hardener in the static mixer.

For installation, the cartridge temperature must be at least +5 °C. For longer installation times, i.e. when interruptions occur in work, the mixer should be replaced.

Anchor and mortars											
											Page
	Positioning										
Mortar cartridges											
 Highbond-System FHB II	The best performance in cracked concrete	–	–	–	–	•	•	•	•	–	54
 Superbond-System FSB	The concrete all-rounder	•	•	•	–	–	–	–	–	•	67
 Epoxy mortar FIS EM Plus	The powerful injection mortar for rebar connections and cracked concrete	•	•	•	–	–	–	–	–	•	79
 Epoxy mortar FIS EB	The basic epoxy mortar for applications in concrete	•	•	–	–	–	–	–	–	•	84
 Epoxy mortar FIS EP	The cost-efficient epoxy mortar for applications in concrete	•	•	–	–	–	–	–	–	–	87
 Injection mortar FIS V Plus	The powerful universal mortar for concrete and masonry	•	•	•	•	–	–	–	–	•	90
 Injection mortar FIS V	The versatile injection mortar for anchorings in masonry and cracked concrete	•	•	•	•	–	–	–	–	•	99
 Injection mortar FIS VL	The solid injection mortar for standard applications in cracked concrete and masonry	•	•	•	•	–	–	–	–	•	107
 Injection mortar FIS Green	The first approved mortar made with renewable raw materials	•	•	•	•	–	–	–	–	–	113
 Injection mortar FIS P Plus	The approved injection mortar for anchorings in masonry and non-cracked concrete	•	•	–	•	–	–	–	–	–	119
 Injection mortar FIS P	The reliable injection mortar for anchorings in masonry	(•)	(•)	–	(•)	–	–	–	–	–	123

Anchor and mortars											
											
		Threaded rod FIS A	Threaded rod RG M	Internal threaded anchor RG M I	Internal threaded socket FIS E	High-bond anchor FHB II-A L / FHB II-AS	High-bond anchor FHB II-A L inject / FHB II-A S inject	FHB dyn	FDA	Rebar	Page
Positioning											
Mortar cartridges											
 Resin capsules FHB II-P, FHB II-PF high speed	The best performance in cracked concrete	-	-	-	-	•	-	-	-	-	54
 Resin capsules RSB	The concrete all-rounder	-	•	•	-	-	-	-	-	-	67
 Resin capsules RM II	Bonded anchor for cracked concrete without drill hole cleaning	-	•	•	-	-	-	-	-	-	75

Threaded rod FIS A

3



Bridges for traffic signs



Steel constructions

Advantages

- The system of anchor rod FIS A and an injection mortar for cracked concrete (M8 to M30) and non-cracked concrete (M6 to M30) can be individually selected based on requirements, thus allowing for a wide range of applications.
- Variable anchorage depths allow for ideal adaptation to the load to be applied, and ensure an optimised installation time and use of materials.
- Push-through installation is possible without any special parts through filling the annular gap with injection mortar.
- The wide range of approved steel types allows for use in all corrosion resistance classes and offers maximum application safety.

Versions

- Zinc-plated steel
- Stainless steel

Building materials

Approved for:

- Concrete C20/25 to C50/60, cracked and non-cracked

Also suitable for:

- Concrete C12/15

Functioning

- The system of threaded rod FIS A and an injection mortar for cracked concrete (M8 to M30) and non-cracked concrete (M6 to M30) can be individually selected based on requirements, thus allowing for a wide range of applications.
- The mortar is extruded bubble free from the drill hole base.
- The mortar bonds the entire surface of the threaded rod with the drill hole wall and seals the drill hole.
- The threaded rod is set manually, by lightly rotating it until it reaches the drill hole base.

Threaded rod FIS A



	zinc plated, steel grade 5.8 gvz Art.-No.	zinc plated, steel grade 8.8 gvz Art.-No.	stainless steel R Art.-No.	FIS SB		FIS EM Plus		FIS EB		FIS EP		FIS V Plus		FIS V		FIS VL		FIS GREEN		FIS P Plus		FIS P	
				Concrete	Concrete	Concrete	Concrete	Masonry	Concrete	Masonry	Concrete	Masonry	Concrete	Masonry	Concrete	Masonry	Concrete	Masonry	Concrete	Masonry	Concrete	Masonry	Concrete
FIS A M 6 x 70	046204	-	-	-	-	-	-	(e)	(e)	•	•	•	•	•	-	-	-	-	-	-	-	-	(e)
FIS A M 6 x 75	090243	-	090437	-	-	-	-	(e)	(e)	•	•	•	•	•	-	-	-	-	-	-	-	-	(e)
FIS A M 6 x 85	090272	-	-	-	-	-	-	(e)	(e)	•	•	•	•	•	-	-	-	-	-	-	-	-	(e)
FIS A M 6 x 110	090273	-	090439	-	-	-	-	(e)	(e)	•	•	•	•	•	-	-	-	-	-	-	-	-	(e)
FIS A M 8 x 90	090274	519390	090440	•	•	•	•	(e)	(e)	•	•	•	•	•	•	•	•	•	•	•	•	•	(e)
FIS A M 8 x 110	090275	519391	090441	•	•	•	•	(e)	(e)	•	•	•	•	•	•	•	•	•	•	•	•	•	(e)
FIS A M 8 x 130	090276	519392	090442	•	•	•	•	(e)	(e)	•	•	•	•	•	•	•	•	•	•	•	•	•	(e)
FIS A M 8 x 175	090277	519393	090443	•	•	•	•	(e)	(e)	•	•	•	•	•	•	•	•	•	•	•	•	•	(e)
FIS A M 8 x 1000	509214 ¹⁾	-	509230 ¹⁾	•	•	•	•	(e)	(e)	•	•	•	•	•	•	•	•	•	•	•	•	•	(e)
FIS A M 10 x 110	090278	-	090444	•	•	•	•	-	-	•	•	•	•	•	•	•	•	•	•	•	•	•	(e)
FIS A M 10 x 130	090279	-	090447	•	•	•	•	-	-	•	•	•	•	•	•	•	•	•	•	•	•	•	(e)
FIS A M 10 x 130	-	524170	-	•	•	•	•	-	-	•	•	•	•	•	•	•	•	•	•	•	•	•	(e)
FIS A M 10 x 150	090281	517935	090448	•	•	•	•	-	-	•	•	•	•	•	•	•	•	•	•	•	•	•	(e)
FIS A M 10 x 170	044969	519395	044973	•	•	•	•	-	-	•	•	•	•	•	•	•	•	•	•	•	•	•	(e)
FIS A M 10 x 190	-	517936	-	•	•	•	•	-	-	•	•	•	•	•	•	•	•	•	•	•	•	•	(e)
FIS A M 10 x 200	090282	519396	090449	•	•	•	•	-	-	•	•	•	•	•	•	•	•	•	•	•	•	•	(e)
FIS A M 10 x 1000	509215 ¹⁾	509223 ¹⁾	509231 ¹⁾	•	•	•	•	-	-	•	•	•	•	•	•	•	•	•	•	•	•	•	(e)
FIS A M 12 x 120	044971	519397	044974	•	•	•	•	-	-	•	•	•	•	•	•	•	•	•	•	•	•	•	(e)
FIS A M 12 x 140	090283	519398	090450	•	•	•	•	-	-	•	•	•	•	•	•	•	•	•	•	•	•	•	(e)
FIS A M 12 x 160	090284	517937	090451	•	•	•	•	-	-	•	•	•	•	•	•	•	•	•	•	•	•	•	(e)
FIS A M 12 x 180	090285	519399	090452	•	•	•	•	-	-	•	•	•	•	•	•	•	•	•	•	•	•	•	(e)
FIS A M 12 x 200	-	517938	519421	•	•	•	•	-	-	•	•	•	•	•	•	•	•	•	•	•	•	•	(e)
FIS A M 12 x 210	090286	-	090453	•	•	•	•	-	-	•	•	•	•	•	•	•	•	•	•	•	•	•	(e)
FIS A M 12 x 260	090287	-	090454	•	•	•	•	-	-	•	•	•	•	•	•	•	•	•	•	•	•	•	(e)
FIS A M 12 x 280	-	-	547703	•	•	•	•	-	-	•	•	•	•	•	•	•	•	•	•	•	•	•	(e)
FIS A M 12 x 1000	509216 ¹⁾	509224 ¹⁾	509232 ¹⁾	•	•	•	•	-	-	•	•	•	•	•	•	•	•	•	•	•	•	•	(e)
FIS A M 16 x 130	044972	519400	044975	•	•	•	•	-	-	•	•	•	•	•	•	•	•	•	•	•	•	-	-
FIS A M 16 x 175	090288	519401	090455	•	•	•	•	-	-	•	•	•	•	•	•	•	•	•	•	•	•	-	-
FIS A M 16 x 200	090289	517939	090456	•	•	•	•	-	-	•	•	•	•	•	•	•	•	•	•	•	•	-	-
FIS A M 16 x 250	090290	517940	090457	•	•	•	•	-	-	•	•	•	•	•	•	•	•	•	•	•	•	-	-
FIS A M 16 x 300	090291	519402	090458	•	•	•	•	-	-	•	•	•	•	•	•	•	•	•	•	•	•	-	-
FIS A M 16 x 1000	509217 ¹⁾	509225 ¹⁾	509233 ¹⁾	•	•	•	•	-	-	•	•	•	•	•	•	•	•	•	•	•	•	-	-
FIS A M 20 x 245	090292	519404	090459	•	•	•	•	-	-	•	-	•	-	•	-	•	-	•	-	•	-	-	-
FIS A M 20 x 290	090293	519406	090460	•	•	•	•	-	-	•	-	•	-	•	-	•	-	•	-	•	-	-	-
FIS A M 20 x 1000	-	519410 ¹⁾	519427 ¹⁾	•	•	•	•	-	-	•	-	•	-	•	-	•	-	•	-	•	-	-	-
FIS A M 24 x 290	090294	-	090461	•	•	•	•	-	-	•	-	•	-	•	-	•	-	•	-	•	-	-	-
FIS A M 24 x 380	090295	-	090462	•	•	•	•	-	-	•	-	•	-	•	-	•	-	•	-	•	-	-	-
FIS A M 24 x 1000	533881	551771	-	•	•	•	•	-	-	•	-	•	-	•	-	•	-	•	-	•	-	-	-
FIS A M 30 x 430	090297	-	090464	•	•	•	•	-	-	•	-	•	-	•	-	•	-	•	-	•	-	-	-
FIS A M 30 x 1000	-	552728	-	•	•	•	•	-	-	•	-	•	-	•	-	•	-	•	-	•	-	-	-

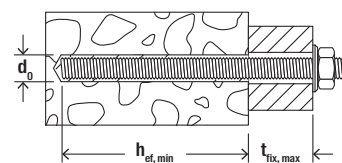

Technical data in concrete

Threaded rod FIS A



FIS A

3

Item	Zinc plated, steel grade 5.8	Zinc plated, steel grade 8.8	Stainless steel	Approval		Drill hole diameter	Min. / max. anchorage depth	Min. / max. usable length	Min. / max. filling quantity FIS SB	Sales unit
	Item No.	Item No.	Item No.	ETA	ICC	d_0 [mm]	[mm]	[mm]	[scale units]	[pcs]
	gvz	gvz	R							
FIS A M 8 x 90	090274	519390	090440	●	●	10	60 / 78	1 / 19	2 / 3	10
FIS A M 8 x 110	090275	519391	090441	●	●	10	60 / 98	1 / 39	2 / 3	10
FIS A M 8 x 130	090276	519392	090442	●	●	10	60 / 118	1 / 59	2 / 4	10
FIS A M 8 x 140	—	553763	—	●	●	10	60 / 129	1 / 70	2 / 2	10
FIS A M 8 x 175	090277	519393	090443	●	●	10	60 / 160	4 / 104	2 / 5	10
FIS A M 8 x 1000	509214 ¹⁾	509222 ¹⁾	509230 ¹⁾	●	●	10	60 / 160	—	2 / 5	10
FIS A M 10 x 110	090278	—	090444	●	●	12	60 / 96	1 / 37	3 / 4	10
FIS A M 10 x 130	090279	524170	090447	●	●	12	60 / 116	1 / 57	3 / 5	10
FIS A M 10 x 150	090281	517935	090448	●	●	12	60 / 136	1 / 77	3 / 5	10
FIS A M 10 x 170	044969	519395	044973	●	●	12	60 / 156	1 / 97	3 / 6	10
FIS A M 10 x 190	—	517936	—	●	●	12	60 / 176	1 / 117	3 / 7	10
FIS A M 10 x 200	090282	519396	090449	●	●	12	60 / 186	1 / 127	3 / 7	10
FIS A M 10 x 1000	509215 ¹⁾	509223 ¹⁾	509231 ¹⁾	●	●	12	60 / 200	—	3 / 7	10
FIS A M 12 x 120	044971	519397	044974	●	●	14	70 / 103	1 / 34	3 / 5	10
FIS A M 12 x 140	090283	519398	090450	●	●	14	70 / 123	1 / 54	3 / 6	10
FIS A M 12 x 160	090284	517937	090451	●	●	14	70 / 143	1 / 74	3 / 7	10
FIS A M 12 x 180	090285	519399	090452	●	●	14	70 / 163	1 / 94	3 / 7	10
FIS A M 12 x 200	—	517938	—	●	●	14	70 / 183	1 / 114	3 / 8	10
FIS A M 12 x 210	090286	—	090453	●	●	14	70 / 193	1 / 124	3 / 9	10
FIS A M 12 x 260	090287	—	090454	●	●	14	70 / 240	4 / 174	3 / 10	10
FIS A M 12 x 1000	509216 ¹⁾	509224 ¹⁾	509232 ¹⁾	●	●	14	70 / 240	—	3 / 10	10
FIS A M 16 x 130	044972	519400	044975	●	●	18	80 / 109	1 / 30	5 / 7	10
FIS A M 16 x 175	090288	519401	090455	●	●	18	80 / 154	1 / 75	5 / 10	10
FIS A M 16 x 200	090289	517939	090456	●	●	18	80 / 179	1 / 100	5 / 11	10
FIS A M 16 x 250	090290	517940	090457	●	●	18	80 / 229	1 / 150	5 / 14	10
FIS A M 16 x 300	090291	519402	090458	●	●	18	80 / 279	1 / 200	5 / 17	10
FIS A M 16 x 350	—	558865	—	●	●	18	80 / 320	10 / 250	4 / 16	10
FIS A M 16 x 1000	509217 ¹⁾	509225 ¹⁾	509233 ¹⁾	●	●	18	80 / 320	—	5 / 19	10
FIS A M 20 x 245	090292	519404	090459	●	●	24	90 / 220	1 / 131	11 / 28	10
FIS A M 20 x 290	090293	519406	090460	●	●	24	90 / 265	1 / 176	11 / 32	10
FIS A M 20 x 350	—	559627	—	●	●	20	90 / 320	6 / 236	24 / 120	10
FIS A M 20 x 400	—	558866	—	●	●	20	90 / 375	1 / 286	10 / 42	10
FIS A M 20 x 1000	—	519410 ¹⁾	519427 ¹⁾	●	●	24	90 / 400	—	11 / 48	10
FIS A M 24 x 290	090294	—	090461	●	●	28	96 / 260	1 / 165	15 / 39	5
FIS A M 24 x 380	090295	—	090462	●	●	28	96 / 350	1 / 255	15 / 52	5
FIS A M 24 x 650	—	558868	—	●	●	28	90 / 480	141 / 525	13 / 63	5
FIS A M 24 x 450	—	558867	—	●	●	30	96 / 420	1 / 325	13 / 63	5
FIS A M 30 x 430	090297	—	090464	●	●	35	120 / 394	1 / 275	27 / 88	5
FIS A M 30 x 550	—	558869	—	●	●	35	120 / 515	1 / 396	24 / 120	5
FIS A M 30 x 650	—	558870	—	●	●	35	120 / 600	16 / 496	24 / 120	5
FIS A M 30 x 750	—	558871	—	●	●	35	120 / 600	116 / 596	24 / 120	5

¹⁾ Order washer and nut separately.

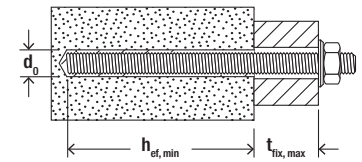

Technical data in solid brick masonry

Threaded rod FIS A



FIS A

Item	Zinc plated, steel grade 5.8	Zinc plated, steel grade 8.8	Stainless steel	Approval	Drill hole diameter	Min. effective anchorage depth acc. ETA	Max. effective length acc. ETA	Fill quantity for effect. anchoring depth	Sales unit
	Item No.	Item No.	Item No.	ETA	d_0 [mm]	[mm]	[mm]	[scale units]	[pcs]
FIS A M 6 x 70	046204	—	—	●	8	50	11	2	10
FIS A M 6 x 75	090243	—	090437	●	8	50	17	2	20
FIS A M 6 x 85	090272	—	—	●	8	50	27	2	20
FIS A M 6 x 110	090273	—	090439	●	8	50	50	2	20
FIS A M 8 x 90	090274	519390	090440	●	10	50	29	2	10
FIS A M 8 x 110	090275	519391	090441	●	10	50	46	2	10
FIS A M 8 x 130	090276	519392	090442	●	10	50	66	2	10
FIS A M 8 x 140	—	553763	—	●	10	—	—	—	10
FIS A M 8 x 175	090277	519393	090443	●	10	50	111	2	10
FIS A M 10 x 110	090278	—	090444	●	12	50	30	3	10
FIS A M 10 x 130	090279	524170	090447	●	12	50	50	3	10
FIS A M 10 x 150	090281	517935	090448	●	12	50	70	3	10
FIS A M 10 x 170	044969	519395	044973	●	12	50	90	3	10
FIS A M 10 x 190	—	517936	—	●	12	50	110	3	10
FIS A M 10 x 200	090282	519396	090449	●	12	50	120	3	10
FIS A M 12 x 120	044971	519397	044974	●	14	50	39	3	10
FIS A M 12 x 140	090283	519398	090450	●	14	50	59	3	10
FIS A M 12 x 160	090284	517937	090451	●	14	50	79	3	10
FIS A M 12 x 180	090285	519399	090452	●	14	50	99	3	10
FIS A M 12 x 200	—	517938	—	●	14	50	119	3	10
FIS A M 12 x 210	090286	—	090453	●	14	50	129	3	10
FIS A M 12 x 260	090287	—	090454	●	14	50	179	3	10
FIS A M 16 x 130	044972	519400	044975	●	18	50	20	6	10
FIS A M 16 x 175	090288	519401	090455	●	18	50	65	6	10
FIS A M 16 x 200	090289	517939	090456	●	18	50	90	6	10
FIS A M 16 x 250	090290	517940	090457	●	18	50	140	6	10
FIS A M 16 x 300	090291	519402	090458	●	18	50	190	6	10
FIS A M 16 x 350	—	558865	—	●	18	—	—	—	10

3

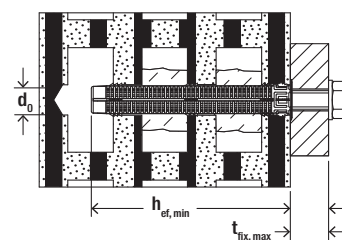

Technical data in perforated brick masonry

Threaded rod FIS A

3



FIS A

Item	Zinc plated, steel grade 5.8	Zinc plated, steel grade 8.8	Stainless steel	Approval	Drill hole diameter in perforated brick masonry	Min. anchorage depth in perforated brick masonry	Max. useful length in perforated brick masonry	Suitable injection anchor sleeve	Sales unit
	Item No.	Item No.	Item No.	ETA	d_0 [mm]	$h_{ef, min}$ [mm]	$t_{fix, max}$ [mm]		[pcs]
Item	gvz	gvz	R	ETA					
FIS A M 6 x 70	046204	—	—	●	12	50	11	FIS H 12 x 50 K	10
FIS A M 6 x 75	090243	—	090437	●	12	50	16	FIS H 12 x 50 K	20
FIS A M 6 x 85	090272	—	—	●	12	50	26	FIS H 12 x 50 K	20
FIS A M 6 x 110	090273	—	090439	●	12	50 85	52 17	FIS H 12 x 50 K FIS H 12 x 85 K	20
FIS A M 8 x 90	090274	519390	090440	●	12	50	29	FIS H 12 x 50 K	10
FIS A M 8 x 110	090275	519391	090441	●	12 12 16	50 85 85	49 14 14	FIS H 12 x 50 K FIS H 12 x 85 K FIS H 16 x 85 K	10
FIS A M 8 x 130	090276	519392	090442	●	12 12 16	50 85 85	69 34 34	FIS H 12 x 50 K FIS H 12 x 85 K FIS H 16 x 85 K	10
FIS A M 8 x 140	—	553763	—	●	12	50 50 85	80 80 45	FIS H 12x50 K FIS H 12x85 K FIS H 16x85 K	10
FIS A M 8 x 175	090277	519393	090443	●	12 12 16 16	50 85 85 130	114 79 79 34	FIS H 12 x 50 K FIS H 12 x 85 K FIS H 16 x 85 K FIS H 16 x 130 K	10
FIS A M 10 x 110	090278	—	090444	●	16	85	12	FIS H 16 x 85 K	10
FIS A M 10 x 130	090279	524170	090447	●	16	85	32	FIS H 16 x 85 K	10
FIS A M 10 x 150	090281	517935	090448	●	16	85 130	52 7	FIS H 16 x 85 K FIS H 16 x 130 K	10
FIS A M 10 x 170	044969	519395	044973	●	16	85 130	72 27	FIS H 16 x 85 K FIS H 16 x 130 K	10
FIS A M 10 x 190	—	517936	—	●	16	85 130	92 47	FIS H 16 x 85 K FIS H 16 x 130 K	10
FIS A M 10 x 200	090282	519396	090449	●	16	85 130	102 57	FIS H 16 x 85 K FIS H 16 x 130 K	10
FIS A M 12 x 120	044971	519397	044974	●	20	85	19	FIS H 20 x 85 K	10
FIS A M 12 x 140	090283	519398	090450	●	20	85	39	FIS H 20 x 85 K	10
FIS A M 12 x 160	090284	517937	090451	●	20	85 130	59 14	FIS H 20 x 85 K FIS H 20 x 130 K	10
FIS A M 12 x 180	090285	519399	090452	●	20	85 130	79 34	FIS H 20 x 85 K FIS H 20 x 130 K	10
FIS A M 12 x 200	—	517938	—	●	20	85 130	99 54	FIS H 20 x 85 K FIS H 20 x 130 K	10
FIS A M 12 x 210	090286	—	090453	●	20	85 130	109 64	FIS H 20 x 85 K FIS H 20 x 130 K	10
FIS A M 12 x 260	090287	—	090454	●	20	85 130 200	169 114 44	FIS H 20 x 85 K FIS H 20 x 130 K FIS H 20 x 200 K	10
FIS A M 16 x 130	044972	519400	044975	●	20	85	25	FIS H 20 x 85 K	10
FIS A M 16 x 175	090288	519401	090455	●	20	85 130	70 25	FIS H 20 x 85 K FIS H 20 x 130 K	10
FIS A M 16 x 200	090289	517939	090456	●	20	85 130	95 50	FIS H 20 x 85 K FIS H 20 x 130 K	10

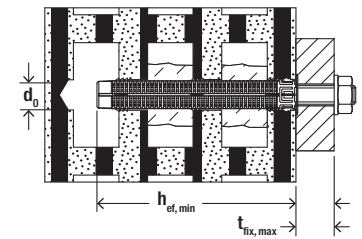

Technical data in perforated brick masonry

Threaded rod FIS A



FIS A

Item	Zinc plated, steel grade 5.8	Zinc plated, steel grade 8.8	Stainless steel	Approval	Drill hole diameter in perforated brick masonry	Min. anchorage depth in perforated brick masonry	Max. useful length in perforated brick masonry	Suitable injection anchor sleeve	Sales unit
	Item No.	Item No.	Item No.		d_0 [mm]	$h_{ef, min}$ [mm]	$t_{fix, max}$ [mm]		[pcs]
FIS A M 16 x 250	090290	517940	090457	●	20	85 130 200	145 100 30	FIS H 20 x 85 K FIS H 20 x 130 K FIS H 20 x 200 K	10
FIS A M 16 x 300	090291	519402	090458	●	20	85 130 200	195 150 80	FIS H 20 x 85 K FIS H 20 x 130 K FIS H 20 x 200 K	10
FIS A M 16 x 350	—	558865	—	●	20 20 22 20	85 85 85 130	245 245 245 200	FIS H 20x85 K FIS H 20x130 K FIS H 22x130/200 K FIS H 20x200 K	10

3

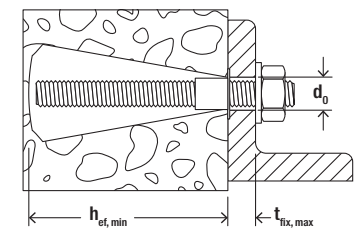

Technical data in undercut drill hole in aerated concrete

Threaded rod FIS A



FIS A

Item	Zinc plated, steel grade 5.8	Zinc plated, steel grade 8.8	Stainless steel	Approval	Drill hole diameter in aerated concrete in undercut drill hole	Min. / max. anchorage depth in aerated concrete in undercut drill hole	Min. / max. usable length in aerated concrete	Filling quantity for min. / max. anchorage depth in aerated concrete	Sales unit
	Item No.	Item No.	Item No.		[mm]	h_{ef} [mm]	t_{fix} [mm]	[scale units]	[pcs]
FIS A M 8 x 90	090274	519390	090440	●	14	75 / 95	4 / -	15 / 20	10
FIS A M 8 x 110	090275	519391	090441	●	14	75 / 95	24 / 4	15 / 20	10
FIS A M 8 x 130	090276	519392	090442	●	14	75 / 95	44 / 24	15 / 20	10
FIS A M 8 x 140	—	553763	—	●	14	75 / 90	55 / 40	15 / 20	10
FIS A M 8 x 175	090277	519393	090443	●	14	75 / 95	89 / 69	15 / 20	10
FIS A M 10 x 110	090278	—	090444	●	14	75 / 95	22 / 2	15 / 20	10
FIS A M 10 x 130	090279	524170	090447	●	14	75 / 95	42 / 22	15 / 20	10
FIS A M 10 x 150	090281	517935	090448	●	14	75 / 95	62 / 42	15 / 20	10
FIS A M 10 x 170	044969	519395	044973	●	14	75 / 95	82 / 62	15 / 20	10
FIS A M 10 x 190	—	517936	—	●	14	75 / 95	102 / 82	15 / 20	10
FIS A M 10 x 200	090282	519396	090449	●	14	75 / 95	112 / 92	15 / 20	10
FIS A M 12 x 120	044971	519397	044974	●	14	75 / 95	29 / 9	15 / 20	10

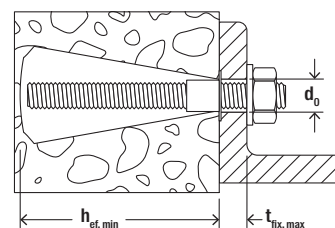

Technical data in undercut drill hole in aerated concrete

Threaded rod FIS A

3



FIS A

Item	Zinc plated, steel grade 5.8	Zinc plated, steel grade 8.8	Stainless steel	Approval	Drill hole diameter in aerated concrete in undercut drill hole	Min. / max. anchorage depth in aerated concrete in undercut drill hole	Min. / max. usable length in aerated concrete	Filling quantity for min. / max. anchorage depth in aerated concrete	Sales unit
	Item No. gvz	Item No. gvz	Item No. R	ETA	[mm]	h_{ef} [mm]	t_{fix} [mm]	[scale units]	[pcs]
FIS A M 12 x 140	090283	519398	090450	●	14	75 / 95	49 / 29	15 / 20	10
FIS A M 12 x 160	090284	517937	090451	●	14	75 / 95	69 / 49	15 / 20	10
FIS A M 12 x 180	090285	519399	090452	●	14	75 / 95	89 / 69	15 / 20	10
FIS A M 12 x 200	—	517938	—	●	14	75 / 95	109 / 89	15 / 20	10
FIS A M 12 x 210	090286	—	090453	●	14	75 / 95	119 / 99	15 / 20	10
FIS A M 12 x 260	090287	—	090454	●	14	75 / 95	169 / 149	15 / 20	10

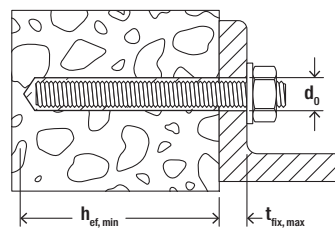

Technical data in cylindrical drill hole in aerated concrete

Threaded rod FIS A



FIS A

Item	Zinc plated, steel grade 5.8	Zinc plated, steel grade 8.8	Stainless steel	Approval	Drill hole diameter in aerated concrete in cylindrical drill hole	Anchorage depth in aerated concrete in cylindrical drill hole	Usable length	Filling quantity for effect. anchorage depth in aerated concrete	Sales unit
	Item No. gvz	Item No. gvz	Item No. R	ETA	d_0 [mm]	h_{ef} [mm]	t_{fix} [mm]	[scale units]	[pcs]
FIS A M 8 x 90	—	—	090440	●	10	100	—	—	10
FIS A M 8 x 110	090275	519391	090441	●	10	100	2	—	10
FIS A M 8 x 130	090276	519392	090442	●	10	100	19	3	10
FIS A M 8 x 140	—	553763	—	●	10	100	—	—	10
FIS A M 8 x 175	090277	519393	090443	●	10	100	64	3	10
FIS A M 10 x 110	090278	—	090444	●	12	100	—	—	10
FIS A M 10 x 130	090279	524170	090447	●	12	100	17	6	10
FIS A M 10 x 150	090281	517935	090448	●	12	100	37	4	10
FIS A M 10 x 170	044969	519395	044973	●	12	100	57	4	10
FIS A M 10 x 190	—	517936	—	●	12	100	77	4	10
FIS A M 10 x 200	090282	519396	090449	●	12	100	87	4	10
FIS A M 12 x 120	044971	519397	044974	●	14	100	4	5	10
FIS A M 12 x 140	090283	519398	090450	●	14	100	24	5	10

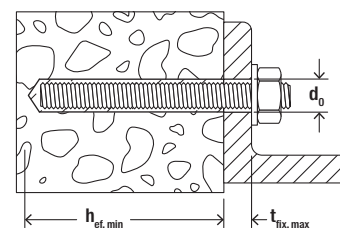

Technical data in cylindrical drill hole in aerated concrete

Threaded rod FIS A



FIS A

Item	Zinc plated, steel grade 5.8	Zinc plated, steel grade 8.8	Stainless steel	Approval	Drill hole diameter in aerated concrete in cylindrical drill hole	Anchorage depth in aerated concrete in cylindrical drill hole	Usable length	Fill quantity for effect. anchorage depth in aerated concrete	Sales unit
	Item No. gvz	Item No. gvz	Item No. R	ETA	d_0 [mm]	h_{ef} [mm]	t_{fix} [mm]	[scale units]	[pcs]
FIS A M 12 x 160	090284	517937	090451	●	14	100	44	5	10
FIS A M 12 x 180	090285	519399	090452	●	14	100	64	5	10
FIS A M 12 x 200	—	517938	—	●	14	100	84	5	10
FIS A M 12 x 210	090286	—	090453	●	14	100	94	5	10
FIS A M 12 x 260	090287	—	090454	●	14	100	144	5	10
FIS A M 16 x 130	044972	519400	044975	●	18	100	10	6	10
FIS A M 16 x 175	090288	519401	090455	●	18	100	55	6	10
FIS A M 16 x 200	090289	517939	090456	●	18	100	80	6	10
FIS A M 16 x 250	090290	517940	090457	●	18	100	130	6	10
FIS A M 16 x 300	090291	519402	090458	●	18	100	180	6	10

Accessories

Hexagonal nut and washer



Hexagonal nut and washer

Item	Zinc plated, steel grade 8.8	Stainless steel	Width across nut	Washer (outer diameter x thickness)	Match	Sales unit
	Item No. gvz	Item No. R	SW [mm]	[mm]	[mm]	[pcs]
Nut & washer M8	510509	—	13	16 x 1,6	FIS A M8	50
Nut & washer M10	510510	—	17	20 x 2	FIS A M10	50
Nut & washer M12	510511	—	19	24 x 2,5	FIS A M12	25
Nut & washer M16	510512	—	24	30 x 3	FIS A M16	20
Nut & washer M20	519737	—	30	37 x 3	FIS A M20	10
Nut & washer M24	552110	—	36	56 x 4	FIS A M24	5
Nut & washer M30	559124	—	46	56 x 4	FIS A M30	5
Nut & washer M8	—	510513	13	16 x 1,6	FIS A M8 R	50
Nut & washer M10	—	510514	17	20 x 2	FIS A M10 R	50
Nut & washer M12	—	510515	19	24 x 2,5	FIS A M12 R	25
Nut & washer M16	—	510516	24	30 x 3	FIS A M16 R	20
Nut & washer M20	—	519738	30	37 x 3	FIS A M20 R	10
Nut & washer M24	—	552111	36	56 x 4	FIS A M24 R	5

Accessories

Filling set



Filling sets for subsequent filling of the annular gap

Item	Item No.	For use with injection mortar	Match	Sales unit [pcs]
Filling set M 12	537218	FIS SB, FIS EM Plus, FIS V	FIS A/RG M 12	10
Filling set M 16	537219	FIS SB, FIS EM Plus, FIS V	FIS A/RG M 16	10
Filling set M 20	537220	FIS SB, FIS EM Plus, FIS V	FIS A/RG M 20	10

Threaded rod RG M

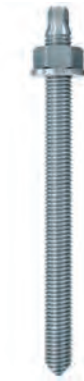

Steel constructions



Underwater applications

3

Advantages

- The wide range of the RG M from M8 to M30 opens up a wide range of applications and therefore offers great flexibility.
- The wide range of approved steel types for RG M allows for use in all corrosion

resistance classes and offers the best possible application safety.

- Please refer to the approvals for the resin capsules and mortar used.

Building materials

Approved for anchorings in:

- Concrete C20/25 to C50/60, cracked and non-cracked

Also suitable for:

- Natural stone with dense structure

Versions

- Zinc-plated steel
- Stainless steel R
- Hot-dip galvanised steel
- Highly corrosion-resistant steel HCR

Functioning

- Due to its oblique edge, the threaded rod RG M is particularly suitable for use in conjunction with resin capsules.
- The threaded rod RG M is set using a hammer drill and the accompanying setting tool in rotating and hitting motions.
- During setting, the oblique edge of the RG M destroys the capsule, and mixes and activates the mortar.
- Use with injection mortar is also possible. Here, the threaded rod is manually inserted into the drill hole with a light rotating movement until it reaches the base of the hole.

Threaded rod RG M



3

	zinc plated, steel grade 5.8 gvz Art.-No.	zinc plated, steel grade 8.8 gvz Art.-No.	stainless steel R Art.-No.	hot-dip galvanized steel hdg Art.-No.	highly corrosion resistant steel HCR Art.-No.	FIS SB Concrete	FIS EM Plus Concrete	FIS EB Concrete	FIS EP Concrete	FIS V Plus Concrete	FIS V Concrete	FIS VL Concrete	FIS GREEN Concrete	FIS P Plus Concrete	FIS P Concrete	RSB Concrete	RM Concrete
RG M 8 x 110	050256	-	050263	-	-	•	•	•	•	•	•	•	•	•	•	•	•
RG M 8 x 150	095698	519443	050293	-	-	•	•	•	•	•	•	•	•	•	•	•	•
RG M 10 x 110	535007	-	535009	-	-	•	•	•	•	•	•	•	•	•	•	•	•
RG M 10 x 130	050257	-	050264	-	096217 ⁹⁾	•	•	•	•	•	•	•	•	•	•	•	•
RG M 10 x 165	050280	-	050294	-	-	•	•	•	•	•	•	•	•	•	•	•	•
RG M 10 x 190	050281	-	050296	-	-	•	•	•	•	•	•	•	•	•	•	•	•
RG M 10 x 220	-	519444	-	-	-	•	•	•	•	•	•	•	•	•	•	•	•
RG M 10 x 250	095703	-	095701	-	-	•	•	•	•	•	•	•	•	•	•	•	•
RG M 10 x 350	095718	-	095709	-	-	•	•	•	•	•	•	•	•	•	•	•	•
RG M 12 x 120	535010	-	535011	-	-	•	•	•	-	•	•	•	•	•	•	•	•
RG M 12 x 160	050258	-	050265	512247	096218 ⁹⁾	•	•	•	-	•	•	•	•	•	•	•	•
RG M 12 x 180	512248	-	512249	-	-	•	•	•	-	•	•	•	•	•	•	•	•
RG M 12 x 200	-	-	050576	-	-	•	•	•	-	•	•	•	•	•	•	•	•
RG M 12 x 220	050283	519445	050297	-	-	•	•	•	-	•	•	•	•	•	•	•	•
RG M 12 x 250	050284	-	095702	-	-	•	•	•	-	•	•	•	•	•	•	•	•
RG M 12 x 300	050285	-	095705	-	-	•	•	•	-	•	•	•	•	•	•	•	•
RG M 12 x 380	095720 ²⁾	-	095710 ⁹⁾	-	-	•	•	•	-	•	•	•	•	•	•	•	•
RG M 16 x 165	050287	-	095704	537062	-	•	•	•	-	•	•	•	•	•	-	•	•
RG M 16 x 140	542407	-	-	-	-	•	•	•	-	•	•	•	•	•	-	•	•
RG M 16 x 190	050259	-	050266	512250	096219 ⁹⁾	•	•	•	-	•	•	•	•	•	-	•	•
RG M 16 x 250	050288	-	050298	-	-	•	•	•	-	•	•	•	•	•	-	•	•
RG M 16 x 270	-	519446	-	-	-	•	•	•	-	•	•	•	•	•	-	•	•
RG M 16 x 300	050289	-	050299	-	-	•	•	•	-	•	•	•	•	•	-	•	•
RG M 16 x 380	095722 ²⁾	-	095712 ⁹⁾	-	-	•	•	•	-	•	•	•	•	•	-	•	•
RG M 16 x 500	095723 ²⁾	-	095713 ⁹⁾	-	-	•	•	•	-	•	•	•	•	•	-	•	•
RG M 20 x 220	512251	-	-	-	-	•	•	•	-	•	•	•	•	•	-	•	•
RG M 20 x 260	050260	-	050267	-	-	•	•	•	-	•	•	•	•	•	-	•	•
RG M 20 x 290	-	519447	-	-	-	•	•	•	-	•	•	•	•	•	-	•	•
RG M 20 x 350	095707	-	095706	-	-	•	•	•	-	•	•	•	•	•	-	•	•
RG M 20 x 500	095725 ⁹⁾	-	-	-	-	•	•	•	-	•	•	•	•	•	-	•	•
RG M 24 x 295	-	519448 ⁹⁾	-	-	-	•	•	•	-	•	•	•	•	•	-	•	•
RG M 24 x 300	050261 ¹⁾	-	050268 ⁹⁾	-	-	•	•	•	-	•	•	•	•	•	-	•	•
RG M 24 x 400	095727 ⁹⁾	-	095715 ⁹⁾	-	-	•	•	•	-	•	•	•	•	•	-	•	•
RG M 24 x 600	095728	-	-	-	-	•	•	•	-	•	•	•	•	•	-	•	•
RG M 30 x 380	050262 ¹⁾	-	090726 ⁹⁾	-	-	•	•	•	-	•	•	•	•	•	-	•	•
RG M 30 x 500	095730 ⁹⁾	-	-	-	-	•	•	•	-	•	•	•	•	•	-	•	•

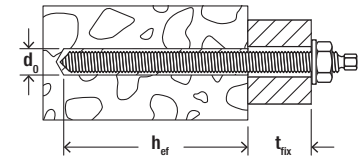

Technical data in concrete

Threaded rod RG M



RG M

Item	Zinc plated, steel grade 5.8	Zinc plated, steel grade 8.8	Stainless steel	Approval	Drill hole diameter	Anchorage depth (short/standard/large)	Usable length (short/standard/large)	Fits capsule RSB	Sales unit
	Item No. gvz	Item No. gvz	Item No. R	ETA	d_0 [mm]	h_{ef} [mm]	t_{fix} [mm]		[pcs]
RG M 8 x 110	050256	—	050263	●	10	- / 80 / -	- / 14 / -	1 x RSB 8	10
RG M 8 x 150	095698	519443	050293	●	10	- / 80 / -	- / 54 / -	1 x RSB 8	10
RG M 10 x 110	535007	—	535009	●	12	75 / - / -	15 / - / -	1 x RSB 10 Mini	10
RG M 10 x 130	050257	—	050264	●	12	75 / 90 / -	35 / 20 / -	1 x RSB 10 mini 1 x RSB 10	10
RG M 10 x 165	050280	—	050294	●	12	75 / 90 / -	70 / 55 / -	1 x RSB 10 mini 1 x RSB 10	10
RG M 10 x 190	050281	—	050296	●	12	75 / 90 / 150	95 / 80 / 20	1 x RSB 10 mini 1 x RSB 10 2 x RSB 10 mini	10
RG M 10 x 220	—	519444	—	●	12	75 / 90 / 150	125 / 110 / 50	1 x RSB 10 mini 1 x RSB 10 2 x RSB 10 mini	10
RG M 10 x 250	095703	—	095701	●	12	75 / 90 / 150	155 / 140 / 80	1 x RSB 10 mini 1 x RSB 10 2 x RSB 10 mini	10
RG M 10 x 350	095718	—	095709	●	12	75 / 90 / 150	255 / 240 / 180	1 x RSB 10 mini 1 x RSB 10 2 x RSB 10 mini	10
RG M 12 x 120	535010	—	535011	●	14	75 / - / -	21 / - / -	1 x RSB 12 mini	10
RG M 12 x 160	050258	—	050265	●	14	75 / 110 / -	61 / 26 / -	1 x RSB 12 mini 1 x RSB 12	10
RG M 12 x 180	512248	—	512249	●	14	75 / 110 / 150	81 / 46 / 6	1 x RSB 12 mini 1 x RSB 12 2 x RSB 12 mini	10
RG M 12 x 200	—	—	050576	●	14	75 / 110 / 150	101 / 66 / 26	1 x RSB 12 mini 1 x RSB 12 2 x RSB 12 mini	10
RG M 12 x 220	050283	519445	050297	●	14	75 / 110 / 150	121 / 86 / 46	1 x RSB 12 mini 1 x RSB 12 2 x RSB 12 mini	10
RG M 12 x 250	050284	—	095702	●	14	75 / 110 / 150	151 / 116 / 76	1 x RSB 12 mini 1 x RSB 12 2 x RSB 12 mini	10
RG M 12 x 300	050285	—	095705	●	14	75 / 110 / 150	201 / 166 / 126	1 x RSB 12 mini 1 x RSB 12 2 x RSB 12 mini	10
RG M 12 x 380	095720 ²⁾	—	095710 ¹⁾	●	14	75 / 110 / 150	281 / 246 / 206	1 x RSB 12 mini 1 x RSB 12 2 x RSB 12 mini	10
RG M 16 x 140	542407	—	—	●	18	95 / - / -	13 / - / -	1 x RSB 16 mini 1 x RSB 16	10
RG M 16 x 165	050287	—	095704	●	18	95 / 125 / -	38 / 8 / -	1 x RSB 16 mini 1 x RSB 16	10
RG M 16 x 190	050259	—	050266	●	18	95 / 125 / -	63 / 33 / -	1 x RSB 16 mini 1 x RSB 16	10
RG M 16 x 250	050288	—	050298	●	18	95 / 125 / 190	123 / 93 / 28	1 x RSB 16 mini 1 x RSB 16 2 x RSB 16 mini	10
RG M 16 x 270	—	519446	—	●	18	95 / 125 / 190	143 / 113 / 48	1 x RSB 16 mini 1 x RSB 16 2 x RSB 16 mini	10

1) Straight cut, additional setting tool required

2) Straight cut, setting tool is enclosed.

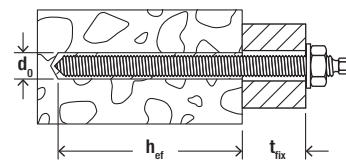

Technical data in concrete

Threaded rod RG M



RG M

3

Item	Zinc plated, steel grade 5.8	Zinc plated, steel grade 8.8	Stainless steel	Approval	Drill hole diameter	Anchorage depth (short/standard/large)	Usable length (short/standard/large)	Fits capsule RSB	Sales unit
	Item No. gvz	Item No. gvz	Item No. R	ETA	d_0 [mm]	h_{ef} [mm]	t_{fix} [mm]		[pcs]
RG M 16 x 300	050289	—	050299	●	18	95 / 125 / 190	173 / 143 / 78	1 x RSB 16 mini 1 x RSB 16 2 x RSB 16 mini	10
RG M 16 x 380	095722 ²⁾	—	095712 ¹⁾	●	18	95 / 125 / 190	253 / 223 / 158	1 x RSB 16 mini 1 x RSB 16 2 x RSB 16 mini	10
RG M 16 x 500	095723 ²⁾	—	095713 ¹⁾	●	18	95 / 125 / 190	373 / 343 / 278	1 x RSB 16 mini 1 x RSB 16 2 x RSB 16 mini	10
RG M 20 x 220	512251	—	—	●	25	- / 170 / -	- / 14 / -	1 x RSB 20	10
RG M 20 x 260	050260	—	050267	●	25	- / 170 / 210	- / 54 / 14	1 x RSB 20 1 x RSB 20 E / 24	10
RG M 20 x 290	—	519447	—	●	25	- / 170 / 210	- / 84 / 44	1 x RSB 20 1 x RSB 20 E / 24	10
RG M 20 x 350	095707	—	095706	●	25	- / 170 / 210	- / 144 / 104	1 x RSB 20 1 x RSB 20 E / 24	10
RG M 20 x 500	095725 ¹⁾	—	—	●	25	- / 170 / 210	- / 294 / 254	1 x RSB 20 1 x RSB 20 E / 24	10
RG M 24 x 295	—	519448 ¹⁾	—	●	28	- / 210 / -	- / 56 / -	1 x RSB 20 E / 24	10
RG M 24 x 300	050261 ¹⁾	—	050268 ¹⁾	●	28	- / 210 / -	- / 61 / -	1 x RSB 20 E / 24	10
RG M 24 x 400	095727 ¹⁾	—	095715 ¹⁾	●	28	- / 210 / -	- / 161 / -	1 x RSB 20 E / 24	10
RG M 24 x 600	095728 ¹⁾	—	—	●	28	- / 210 / -	- / 361 / -	1 x RSB 20 E / 24	5
RG M 30 x 380	050262 ¹⁾	—	090726 ¹⁾	●	35	- / 280 / -	- / 65 / -	1 x RSB 30	5
RG M 30 x 500	095730 ¹⁾	—	—	●	35	- / 280 / -	- / 185 / -	1 x RSB 30	5

1) Straight cut, additional setting tool required

2) Straight cut, setting tool is enclosed.

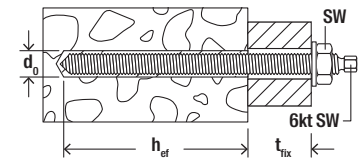

Technical data in concrete

Threaded rod RG M



RG M

Item	Highly corrosion resistant steel	Hot-dip galvanised steel	Approval	Drill hole diameter	Effect. anchorage depth	Max. fixture thickness	Fits capsule RSB	Hexagon drive	Hexagon nut	Sales unit
	Item No.	Item No.		d_0 [mm]	h_{ef} [mm]	t_{fix} [mm]		6kt SW [mm]	SW [mm]	
	HCR	hdg	ETA							
RG M 10 x 130	096217	—	●	12	90	20	1 x RSB 10 mini 1 x RSB 10	7	17	10
RG M 12 x 160	096218	512247	●	14	110	25	1 x RSB 12 mini 1 x RSB 12	8	19	10
RG M 16 x 165	—	537062	●	18	125	8	1 x RSB 16 mini 1 x RSB 16	12	24	10
RG M 16 x 190	096219	512250	●	18	125	35	1 x RSB 16 mini 1 x RSB 16	12	24	10

Accessories

Filling set



Filling sets for subsequent filling of the annular gap

Item	Item No.	For use with injection mortar	Match	Sales unit [pcs]
Filling set M 12	537218	FIS SB, FIS EM Plus, FIS V	FIS A/RG M 12	10
Filling set M 16	537219	FIS SB, FIS EM Plus, FIS V	FIS A/RG M 16	10
Filling set M 20	537220	FIS SB, FIS EM Plus, FIS V	FIS A/RG M 20	10

Internal-threaded anchor RG M I

3

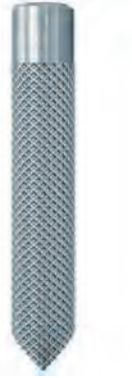

Column bases



Pumps

Advantages

- The system internal threaded anchor RG M I and an injection mortar for concrete can be individually selected based on requirements, thus allowing for a wide range of applications.
- The internal threaded anchor RG M I allows for surface flush removal and reuse of the fixing point, and therefore offers the best possible flexibility.
- The metric internal thread allows for the use of standard screws or threaded rods for the ideal adaptation to suit the intended use.

Versions

- Zinc-plated steel
- Stainless steel

Building materials

Approved for:

- Concrete C20/25 to C50/60, non-cracked

Also suitable for:

- Concrete C12/15, non-cracked

Functioning

- The injection system is suitable for pre-positioned installation when combined with the internal threaded anchor RG M I.
- The mortar is extruded bubble free from the drill hole base.
- The mortar bonds the entire surface of the internal threaded anchor with the drill hole wall and seals the drill hole.
- The internal threaded anchor is set manually, by lightly rotating it until it reaches the drill hole base.

Threaded rod RG M I

	zinc plated, steel grade 5.8 gvz Art.-No.	stainless steel R Art.-No.									
			FIS SB Concrete	FIS EM Plus Concrete	FIS V Plus Concrete	FIS V Concrete	FIS VL Concrete	FIS Green Concrete	RSB Concrete	RM II Concrete	
RG 8 x 75 M 5 I	48221	–	–	–	–	–	–	–	–	–	–
RG 10 x 75 M 6 I	48222	–	–	–	–	–	–	–	–	–	–
RG 12 x 90 M 8 I	50552	50565	•	•	•	•	•	•	•	•	•
RG 16 x 90 M 10 I	50553	50566	•	•	•	•	•	•	•	•	•
RG 18 x 125 M 12 I	50562	50567	•	•	•	•	•	•	•	•	•
RG 22 x 160 M 16 I	50563	50568	•	•	•	•	•	•	•	•	•
RG 28 x 200 M 20 I	50564	50569	•	•	•	•	•	•	•	•	•

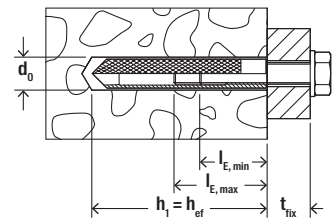

Technical data

Internal-threaded anchor RG M I



RG M I

Item	Zinc-plated steel	Stainless steel	Drill hole diameter d_0 [mm]	Effect. anchorage depth h_{ef} [mm]	Min. bolt penetration $l_{E,min}$ [mm]	Max. bolt penetration $l_{E,max}$ [mm]	Fits capsules	Sales unit
	Item No. gvz	Item No. R						[pcs]
RG 8 x 75 M 5 I	048221 ¹⁾	—	10	75	8	14	539796 RM II 8	10
RG 10 x 75 M 6 I	048222 ¹⁾	—	12	75	10	16	539797 RM II 10	10
RG 12 x 90 M 8 I	050552 ¹⁾	050565 ¹⁾	14	90	8	18	539797 RM II 10	10
RG 16 x 90 M10 I	050553 ¹⁾	050566 ¹⁾	18	90	10	23	539798 RM II 12	10
RG 18 x 125 M12 I	050562 ¹⁾	050567 ¹⁾	20	125	12	26	539800 RM II 16	10
RG 22 x 160 M16 I	050563 ¹⁾	050568 ¹⁾	24	160	16	35	539801 RM II 16 E	5
RG 28 x 200 M20 I	050564 ¹⁾	050569 ¹⁾	32	200	20	45	539803 RM II 24	5

1) Setting tool is included in each package.

Approval Seismic C1/C2 only with maximum embedment depth

Internal threaded sockets FIS E

3



Cable duct

Advantages

- The fixing system threaded rod FIS A and an injection mortar can be individually selected based on requirements, thus allowing for a wide range of applications.
- The wide range of approved threaded rods FIS A from M6 to M16 allows for various applications.
- The internal threaded anchor FIS E allows for surface flush removal and reuse of the fixing point, and therefore offers the best possible flexibility.

Versions

- Zinc-plated steel
- Stainless steel

Building materials

Approved for:

- Solid sand-lime brick
- Solid brick

Also suitable for:

- Solid and lightweight concrete blocks
- Solid pumice and other solid building materials

Functioning

- FIS E is suitable for pre-positioned installation, whilst FIS A is suitable for pre-positioned and push-through installation.
- The mortar bonds the entire surface of the anchor with the drill hole wall and seals the drill hole.
- The anchor is set manually, by lightly rotating it until it reaches the drill hole base.

Internal threaded sockets FIS E							
	Zinc plated, steel grade 5.8 gvz Art.-No.	Stainless steel R Art.-No.	FIS V Plus	FIS V	FIS VL	FIS P Plus	FIS GREEN
FIS E 11 x 85 M6	43631	–	•	•	•	•	•
FIS E 11 x 85 M8	43632	562060	•	•	•	•	•
FIS E 15 x 85 M10	43633	562061	•	•	•	•	•
FIS E 15 x 85 M12	43634	–	•	•	•	•	•

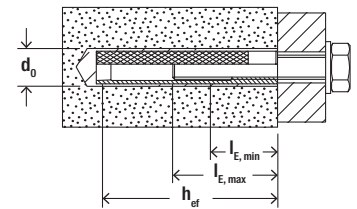

Technical data in solid brick masonry

Internal threaded sockets FIS E



FIS E

Item	Zinc-plated steel	Stainless steel	Approval	Drill hole diameter	Effect. anchorage depth	Min. bolt penetration	Max. bolt penetration	Fill quantity for effect. anchorage depth in solid brick masonry [scale units]	Sales unit [pcs]
	Item No.	Item No.		d_0 [mm]	h_{ef} [mm]	$l_{E,min}$ [mm]	$l_{E,max}$ [mm]		
	gvz	R	ETA						
FIS E 11 x 85 M6	043631	—	●	14	85	6	60	4	10
FIS E 11 x 85 M8	043632	562060	●	14	85	8	60	4	10
FIS E 15 x 85 M10	043633	562061	●	18	85	10	60	5	10
FIS E 15 x 85 M12	043634	—	●	18	85	12	60	5	10

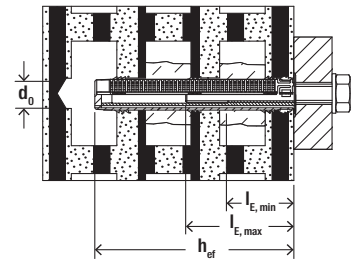

Technical data in perforated brick masonry

Internal threaded sockets FIS E



FIS E

Item	Zinc-plated steel	Stainless steel	Approval	Drill hole diameter in perforated brick masonry	Effect. anchorage depth	Min. bolt penetration	Max. bolt penetration	Suitable injection anchor sleeve	Sales unit [pcs]
	Item No.	Item No.		d_0 [mm]	h_{ef} [mm]	$l_{E,min}$ [mm]	$l_{E,max}$ [mm]		
	gvz	R	ETA						
FIS E 11 x 85 M6	043631	—	●	16 20	85	6	60	FIS H 16 x 85 K FIS H 20 x 85 K	10
FIS E 11 x 85 M8	043632	562060	●	16 20	85	8	60	FIS H 16 x 85 K FIS H 20 x 85 K	10
FIS E 15 x 85 M10	043633	562061	●	20	85	10	60	FIS H 20 x 85 K	10
FIS E 15 x 85 M12	043634	—	●	20	85	12	60	FIS H 20 x 85 K	10

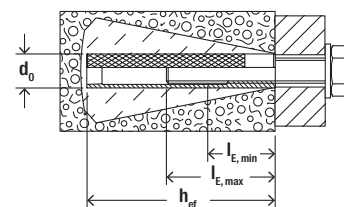

Technical data in undercut drill hole in aerated concrete

Internal threaded sockets FIS E



FIS E

Item	Zinc-plated steel	Stainless steel	Approval	Drill hole diameter in undercut drill hole	Min. anchorage depth in undercut drill hole	Min. bolt penetration	Max. bolt penetration	Fill quantity for effect. anchorage depth in aerated concrete	Sales unit
	Item No.	Item No.		[mm]	[mm]	$l_{E,min}$ [mm]	$l_{E,max}$ [mm]		
	gvz	R	ETA						
FIS E 11 x 85 M6	043631	—	●	14	85	6	60	4	10
FIS E 11 x 85 M8	043632	562060	●	14	85	8	60	4	10

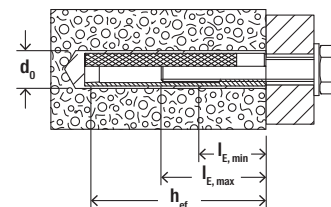

Technical data in cylindrical drill hole in aerated concrete

Internal threaded sockets FIS E



FIS E

Item	Zinc-plated steel	Stainless steel	Approval	Drill hole diameter in cylindrical drill hole	Min. anchorage depth in cylindrical drill hole	Min. bolt penetration	Max. bolt penetration	Fill quantity for effect. anchorage depth in aerated concrete	Sales unit
	Item No.	Item No.		[mm]	h_{ef} [mm]	$l_{E,min}$ [mm]	$l_{E,max}$ [mm]		
	gvz	R	ETA						
FIS E 11 x 85 M6	043631	—	●	14	85	6	60	4	10
FIS E 11 x 85 M8	043632	562060	●	14	85	8	60	4	10
FIS E 15 x 85 M10	043633	562061	●	18	85	10	60	5	10
FIS E 15 x 85 M12	043634	—	●	18	85	12	60	5	10

Accessories for push-through installation

Simple push-through installation in masonry



Car ports



Detail: Wood constructions in push-through installation

3

Applications

- Timber constructions
- Awnings
- Canopies
- Car ports
- Gates

Advantages

- The direct installation through the fixture reduces preliminary work wherever there are several fixing points for each fixture, and guarantees a significantly simpler installation process.
- The design of the push-through anchor sleeve FIS H K allows for a range of usable lengths with just one product, thus providing maximum flexibility and

cost-effectiveness.

- The movable edge, in combination with the scale, makes it easier to adapt the anchor sleeve to suit the desired usable length.
- The grating structure of the push-through anchor sleeve is adapted for the injection mortars FIS V Plus, FIS V, FIS GREEN and FIS P Plus, and ensures sparing mortar use with the best interlock.

Certificates



ETA-10/0383, for masonry

ETA-11/0419, for masonry

ETA-14/0471, for masonry

ETA-20/0729, for masonry

Building materials

Approved for:

- Vertically perforated brick
- Hollow blocks made from lightweight concrete
- Hollow blocks made from concrete
- Perforated sand-lime brick
- Solid sand-lime brick
- Solid brick

Also suitable for:

- Hollow pumice slabs
- Slabs made of hollow brick and other perforated brick
- Solid pumice and other solid building materials

Versions

- Zinc-plated steel
- Stainless steel

Functioning

- The system can be used with any of the following injection mortars: FIS V Plus, FIS V, FIS GREEN and FIS P Plus can be used but does not have approvals.
- The injection system is suitable for push-through installation when combined with the push-through anchor sleeve FIS H K.
- The push-through anchor sleeve is adapted to suit the fixture thickness using the scale and the movable edge, and cut as required.
- The anchor sleeve is placed in the drill hole, and filled with injection mortar from the anchor sleeve base. It should be ensured that the anchor sleeve is completely filled, including in the fixture region.
- Turning in the anchor causes the mortar to be pushed through the anchor sleeve's grating structure, so that it fits the base material perfectly. The load is borne by the interlock.

Installation with FIS V and FIS HK

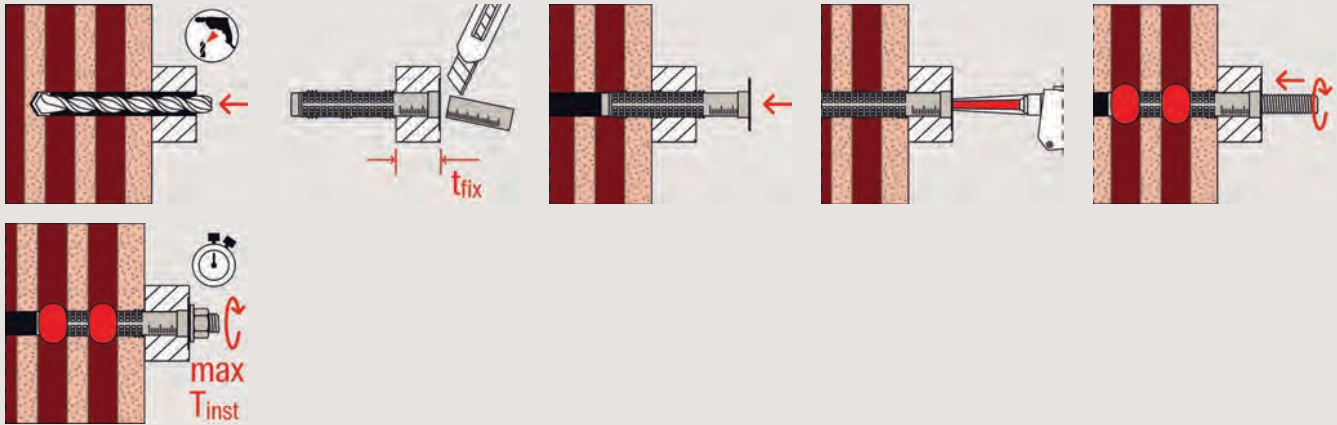

3

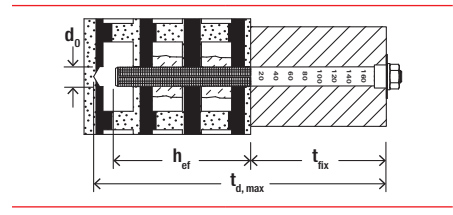

Technical data

Injections anchor sleeve FIS HK



FIS HK

Item	Item No. gvz	Approval ETA	Drill hole diameter d_0 [mm]	Max. drill hole depth [mm]	Effect. anchorage depth h_{ef} [mm]	Max. fixture thickness t_{fix} [mm]	Match	Fill quantity [scale units]	Sales unit [pcs]
FIS H 18 x 130/200 K	045707	●	18	340	130	200	M10 - M12	35	10
FIS H 22 x 130/200 K	045708	●	22	340	130	200	M 16	45	10

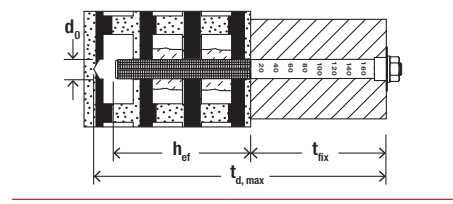

Technical data

FIS Set



FIS Set

Item	Zinc-plated steel Item No. gvz	Stainless steel Item No. R	Approval ETA	Drill hole diameter d_0 [mm]	Max. drill hole depth [mm]	Effect. anchorage depth h_{ef} [mm]	Max. fixture thickness t_{fix} [mm]	Fill quantity [scale units]	Sales unit [pcs]
FIS Set 18 x 130/200 M12/200	047443	047452	●	18	340	130	200	35	5

Injection anchor sleeves

FIS H K



Advantages

- The grating structure of the FIS H K anchor sleeve is adapted for the injection mortars FIS V Plus, FIS V, FIS VL, FIS GREEN, FIS P Plus and FIS P, and ensures sparing mortar use with the best interlock.
- The centring blades perfectly align the anchor in the anchor sleeve, and allow for use with various threaded rod diameters.
- The barbed hooks secure the anchor sleeve in the drill hole and allow for a trouble-free overhead installation.
- The geometry of the anchor sleeves allows for the bridging of non-bearing layers for a simple and convenient installation.

Functioning

- The system can be used with any of the following injection mortars: FIS V Plus, FIS VW Plus High Speed, FIS VS Plus Low Speed, [... FIS V], FIS VL, FIS GREEN or FIS P Plus. FIS P can be used but does not have approvals.
- The system is suitable for pre-positioned installation when combined with injection anchor sleeves and threaded rods FIS A or internal threaded anchors FIS E.
- The anchor sleeve is placed in the drill hole, and filled with injection mortar from the anchor sleeve base.
- Turning in the anchor causes the mortar to be pushed through the anchor sleeve's grating structure, so that it fits the base material perfectly. The load is borne by the interlock.

FIS H L



Advantages

- The metal anchor sleeve can be cut to the required length and thus allows for a range of usable lengths with just one produce, providing flexibility and cost-effectiveness.
- The grating structure of the anchor sleeve allows for uniform distribution of mortar in the drill hole and thus for secure hold.

Functioning

- The anchor sleeve is at first cut to the required length.
- The anchor sleeve is placed in the drill hole, and filled with injection mortar from the anchor sleeve base.
- Turning in the anchor causes the mortar to be pushed through the anchor sleeve's grating structure, so that it fits the base material perfectly.
- The load is borne by the interlock.

FIS H N



Advantage

- The net structure of the anchor sleeve allows for uniform distribution of mortar in the drill hole and thus for secure hold.

Functioning

- The anchor sleeve is placed in the drill hole, and filled with injection mortar from the anchor sleeve base.
- Turning in the anchor causes the mortar to be pushed through the anchor sleeve's grating structure, so that it fits the base material perfectly.
- The load is borne by the interlock.

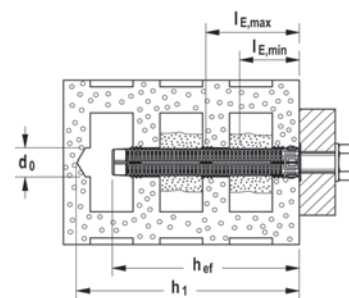

Technical data

3

Injection anchor sleeves FIS H K



FIS H K

Item	Item No.	Approval ETA	Drill hole diameter d_0 [mm]	Drill hole depth acc. ETA [mm]	Effect. anchorage depth h_{ef} [mm]	Match	Fill quantity per sleeve [scale units]	Sales unit [pcs]
FIS H 12 x 50 K	041900	●	12	55	50	FIS A M6-M8	5	50
FIS H 12 x 85 K	041901	●	12	90	85	FIS A M6-M8	10	50
FIS H 16 x 85 K	041902	●	16	90	85	FIS A M8-M10, FIS E M6-M8	12	50
FIS H 16 x 130 K	041903	●	16	135	110	FIS A M8-M10	15	20
FIS H 20 x 85 K	041904	●	20	90	85	FIS A M12-M16, FIS E M10-M12	15	20
FIS H 20 x 130 K	046703	●	20	135	110	FIS A M12-M16	25	20
FIS H 20 x 200 K	046704	●	20	205	180	FIS A M12-M16	40	20

Technical data

Injection anchor sleeves FIS H L



FIS H L

Item	Item No.	Drill hole diameter d_0 [mm]	Total length l [mm]	Match	Fill quantity per 10 cm	Sales unit [pcs]
FIS H 12 x 1000 L	050598	12	1000	Ø6/M6 - Ø8/M8	12	10
FIS H 16 x 1000 L	050599	16	1000	Ø8/M8 - Ø10/M10	14	10
FIS H 22 x 1000 L	045301	22	1000	Ø12/M12 - Ø16/M16	20	6
FIS H 30 x 1000 L	000645	30	1000	Ø16/M16 - Ø22/M22	26	4

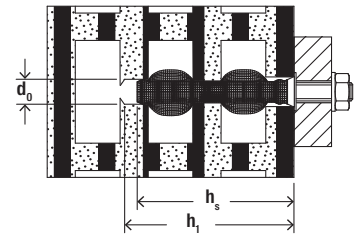

Technical data

Injection anchor sleeve with net FIS H N



FIS H N

Item	Item No.	Drill hole diameter d_0 [mm]	Min. drill hole depth h_1 [mm]	Min. anchorage depth anchor h_v [mm]	Fill quantity per sleeve [scale units]	Match	Sales unit [pcs]
FIS H 16 x 85 N	050470	16	95	85	15	Ø8/M8	20
FIS H 18 x 85 N	050472	18	95	85	17	Ø10/M10	20
FIS H 20 x 85 N	050474	20	95	90	18	Ø12/M12	20

Special Applications										
										Page
	Positioning	FIS HB	FIS SB	FIS EM Plus	FIS EB	FIS V Plus	FIS V	FIS VL	RSB	
Item										
 Highbond anchor dynamic FHB dyn	Performance class amongst dynamic anchors	•	–	–	–	–	–	–	–	153
 Dynamic-anchor FDA	Dynamic push-through anchor for an economical serial installation at medium load level	•	–	–	–	–	–	–	–	167
 FIS A	Dynamic fixation with Superbond-System FSB	–	•	–	–	–	–	–	–	128
 RG M	Dynamic fixation with Superbond-System FSB	–	•	–	–	–	–	–	•	137
 Rebar Connections	Professional rebar connections	–	•	•	•	•	•	•	–	170
 Concrete- Concrete Shear Connector FCC	Approved system for building renovation	–	•	•	–	•	•	–	–	177
 Remedial Wall Tie VBS 8	Facade repair for two-leaf cavity walls	–	–	–	–	•	•	–	–	179
 Weather Facing Reconstruction System FWS II	Economical repair of triple-skin outer wall panels	–	–	–	–	•	•	–	–	181

Highbond anchor dynamic FHB dyn

The performance class amongst dynamic anchors

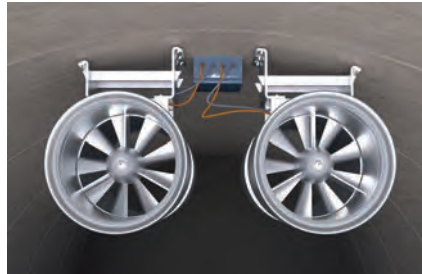

Tunnel ventilators

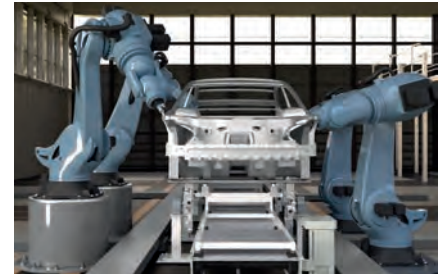

Production robots

3

Applications

- Jib cranes
- Gantry and overhead cranes
- Guide rails for elevators
- Tunnel ventilators (jet fans)
- Gantries in road construction
- Antennas and transmitter masts
- Industrial robots

Advantages

- During the setting process, the injection mortar FIS HB fills the annular gap in the fixture, and ensures optimum load distribution. This allows for the absorption of dynamic alternating loads.
- The cone shape of the FHB-A dyn anchor rod ensures a controlled expansion under dynamic stress, thus allowing for use in cracked concrete.
- The anchor rod FHB-A dyn is also avail-

ble made from highly corrosion-resistant steel. This makes it suitable for use in aggressive atmospheres, for example in tunnels.

- The Highbond anchor dynamic system can achieve even greater shear loads thanks to the additional sleeve of the anchor rod FHB-A dyn V, and therefore provides an increased level of safety.

Certificates



Fire resistance classification
R120

Building materials

Approved for:

- Concrete C20/25 to C50/60, cracked and non-cracked

Versions

- Zinc-plated steel
- Highly corrosion-resistant steel

Functioning

- The injection system suitable for tensile zones consists of the Highbond dynamic anchor rod FHB-A dyn and the injection mortar FIS HB.
- FHB dyn is approved for pre-positioned and push-through installation.
- Extruding the mortar causes the two components to be mixed and activated in the static mixer.
- The mortar bonds the entire surface of the anchor rod with the drill hole wall and seals the drill hole.
- The centring sleeve centres the anchor in the fixture, thus ensuring a safe load application.
- The lock nut prevents the nut from becoming loose.

Pre-positioned installation in concrete with FIS HB and FHB DYN

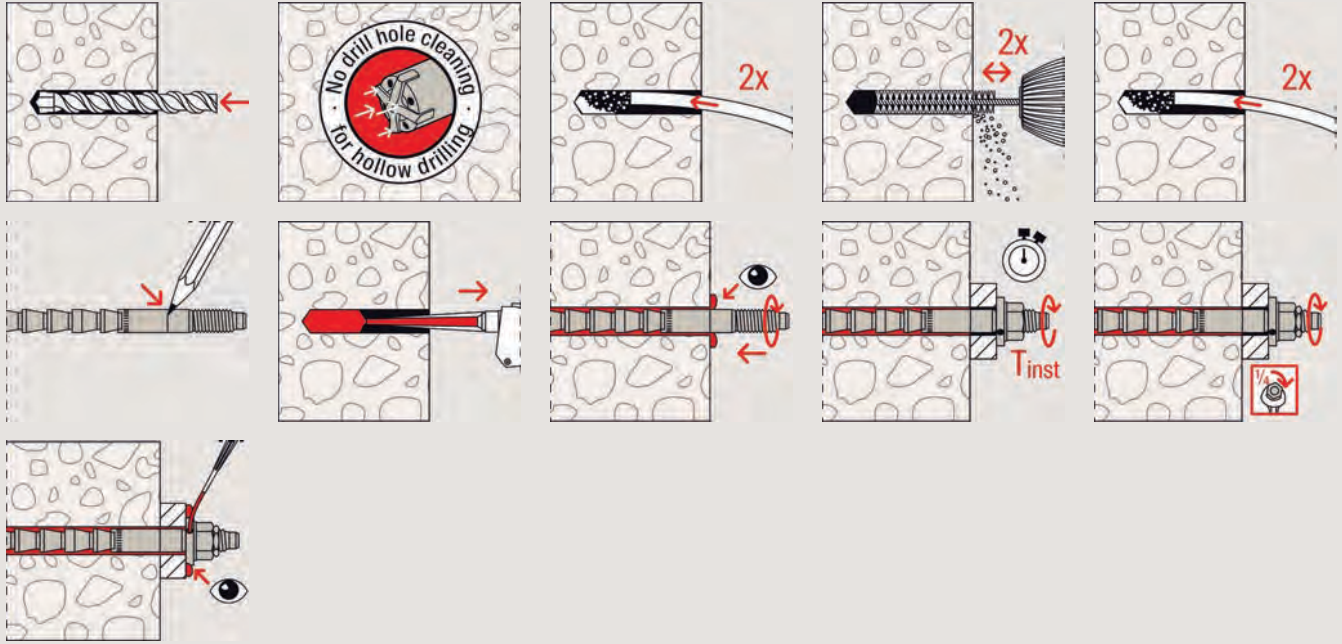

Push-through installation in concrete with FIS HB and FHB DYN

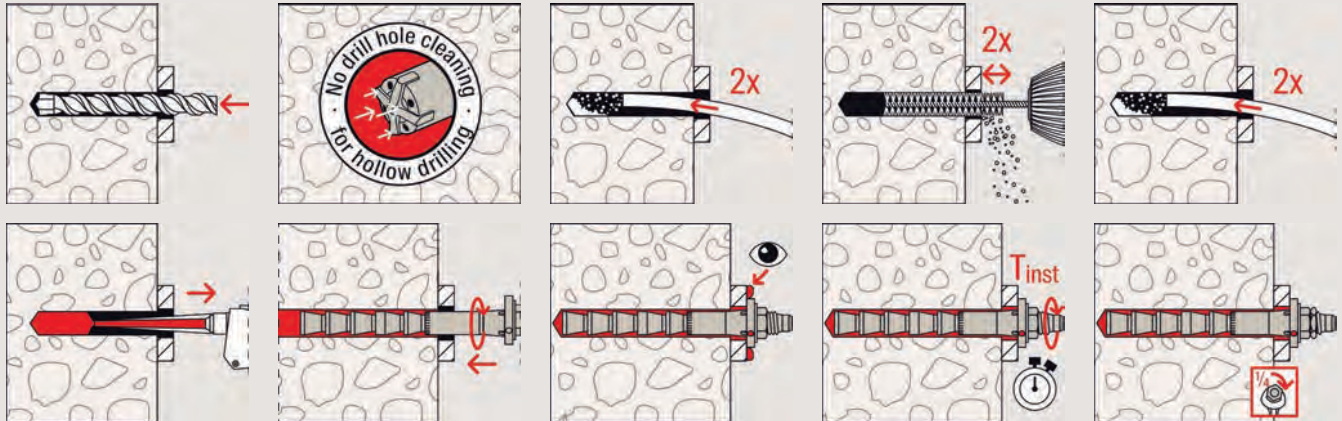

Push-through installation in concrete with FIS HB and FHB DYN V

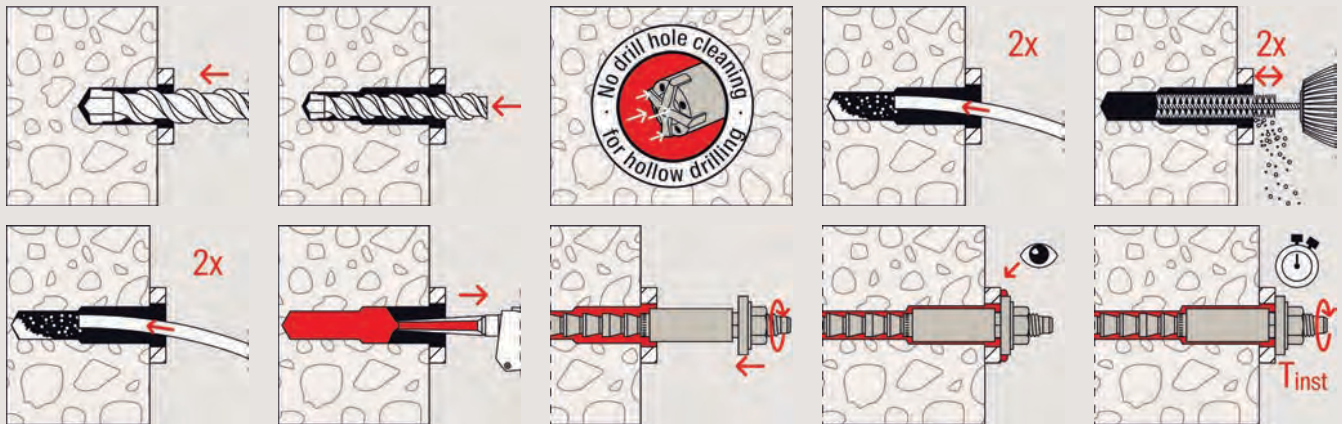

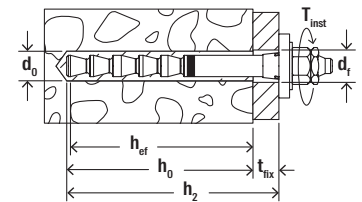

Technical data

Highbond-Anchor dynamic FHB-A dyn



FHB-A dyn

	Zinc-plated steel	Highly corrosion resistant steel	Approval	Drill hole diameter	Min. drill hole depth for through fixings	Anchorage depth	Min. - max. usable length	Drill hole diameter in fixture	Width across nut	Sales unit
	Item No.	Item No.		d_0 [mm]	h_2 [mm]	h_{ef} [mm]	t_{fix} [mm]	d_f [Ø mm]	SW [mm]	[pcs]
Item	gvz	HCR	DIBt							
FHB-A dyn 12 x 100/25	092018	531384 ¹⁾	●	14	130	100	8 - 25	15	19	10
FHB-A dyn 12 x 100/50	092019	—	●	14	155	100	8 - 50	15	19	10
FHB-A dyn 16 x 125/25	092020	—	●	18	155	125	10 - 25	19	24	10
FHB-A dyn 16 x 125/50	092036	093445 ¹⁾	●	18	180	125	10 - 50	19	24	10
FHB-A dyn 16 x 125/50	—	561727 ¹⁾	●	18	180	125	10 - 50	19	24	4
FHB-A dyn 16 x 125/75	562302	—	●	18	205	125	10 - 75	19	24	10
FHB-A dyn 16 x 125/80	541874	—	●	18	210	125	10 - 80	19	24	10
FHB-A dyn 16 x 125/100	541875	—	●	18	230	125	10 - 100	19	24	10
FHB-A dyn 16 x 125/125	541873	—	●	18	255	125	10 - 125	19	24	10
FHB-A dyn 16 x 125/150	543657	—	●	18	280	125	10 - 150	19	24	10
FHB-A dyn 20 x 170/50	092037	—	●	24	225	170	12 - 50	25	30	10
FHB-A dyn 24 x 220/50	092038	—	●	28	275	220	14 - 50	29	36	5

1) Prices and delivery time on request.

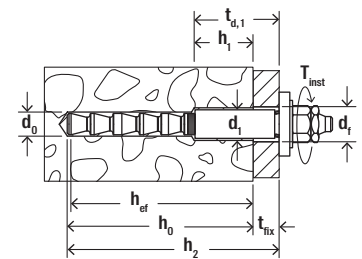

Technical data

Highbond anchor dynamic FHB-A dyn V



FHB-A dyn V

	Zinc-plated steel	Approval	Drill hole diameter	Min. drill hole depth for through fixings	Anchorage depth	Min. - max. usable length	Drill hole diameter in fixture	Width across nut	Sales unit
	Item No.		d_0 [mm]	h_2 [mm]	h_{ef} [mm]	t_{fix} [mm]	d_f [Ø mm]	SW [mm]	[pcs]
Item	gvz	DIBt							
FHB-A dyn 12 x 100/50 V	092039 ¹⁾	●	14	160	105	8 - 50	21	19	10
FHB-A dyn 16 x 125/50 V	092040 ²⁾	●	18	185	130	10 - 50	29	24	10

1) Stepped hole: 1st drill hole with Ø 20 mm and depth 85 mm. 2nd drill hole with Ø 14 mm and depth 160 mm.

2) Stepped hole: 1st drill hole with Ø 28 mm and depth 100 mm. 2nd drill hole with Ø 18 mm and depth 185 mm.

Technical data

Injection mortar FIS HB



FIS HB 150 C

FIS HB 345 S

FIS HB 360 S + FIS MR Plus

FIS MR Plus

Item	Item No.	Approval ETA	Languages on the cartridge	Contents	Sales unit [pcs]
FIS HB 150 C	519665	●	DE, FR, NL	1 cartridge 145 ml, 2 x FIS MR Plus	6
FIS HB 345 S	033211 ¹⁾	●	DE, EN, FR, ES, NL, CS	1 cartridge 360 ml, 2 x FIS MR Plus	6
FIS HB 360 S	562659	●	DE, FR, IT, NL	1 cartridge 360 ml, 2 x FIS MR Plus	6
FIS HB 360 S	562658	●	EN, ZH	1 cartridge 360 ml, 2 x FIS MR Plus	6
FIS HB 360 S	562660	●	EN, PL, RU, CS, SK	1 cartridge 360 ml, 2 x FIS MR Plus	6
FIS HB 360 S	562661	●	EN, ES, PT, EL	1 cartridge 360 ml, 2 x FIS MR Plus	6
FIS HB 360 S	519125	●	DE	1 cartridge 360 ml, 2 x FIS MR Plus	6
FIS MR Plus	545853	—	—	10 static mixer FIS MR Plus	10

1) incl. 2 static mixer per cartridge.

Curing times

FIS HB System temperature FIS HB (Mortar min. +5 °C) [°C]	Maximum processing time FIS HB t_{work} [min.]	Minimum curing time FIS HB ¹⁾ t_{cure} [min.]
-5 – -1	–	360
0 – +4	–	180
> +5 – +9	15	90
> +10 – +19	6	35
> +20 – +29	4	20
> +30 – +40	2	12

1) In wet concrete the curing times must be doubled.

Filling quantities

FHB dyn Type	Mortar volume in scale units shown on the cartridge labels' corresponding scala	Anchor per cartridge FIS HB 360 S ^{*)}
FHB-A dyn 12 x 100 / 25	7	24
FHB-A dyn 12 x 100 / 50	8	21
FHB-A dyn 16 x 125 / 25	9	18
FHB-A dyn 16 x 125 / 50	10	17
FHB-A dyn 20 x 170 / 50	23	7
FHB-A dyn 24 x 220 / 50	38	4
FHB-A dyn 12 x 100 / 50 V	12	14
FHB-A dyn 16 x 125 / 50 V	20	8

*) Max. number with one static mixer.

Loads

Highbond anchor dynamic FHB dyn

Design values for cyclic fatigue loading¹⁾ of a single anchor normal concrete of strength class C20/25²⁾.
For the design the complete current approval Z-21.3-1748 has to be considered.

Type	Material/surface	Effective anchorage depth h_{ef} [mm]	Minimum member thickness h_{min} [mm]	Installation torque T_{inst} [Nm]	Cracked and non-cracked concrete			
					Design values of tension ($\Delta N_{Ed,max}$) and shear loads ($\Delta V_{Ed,max}$); minimum spacing (s_{min}) and edge distances (c_{min}) with reduced loads			
					$\Delta N_{Ed,max}$ ³⁾ [kN]	$\Delta V_{Ed,max}$ ³⁾⁴⁾ [kN]	s_{min} ⁴⁾ [mm]	c_{min} ⁴⁾ [mm]
FHB dyn 12 x 100	gvz	100	130	40	14.1	6.7	100	200 ⁵⁾
	gvz	100	200	40	14.1	6.7	100	100 ⁵⁾
	HCR / 1.4529	100	130	40	11.3	4.4	100	200 ⁵⁾
	HCR / 1.4529	100	200	40	11.3	4.4	100	100 ⁵⁾
FHB dyn 12 x 100 V	gvz	105	130	40	14.1	9.6	100	200 ⁵⁾
	gvz	105	200	40	14.1	9.6	100	100
FHB dyn 16 x 125	gvz	125	160	60	23.0	11.9	100	200 ⁵⁾
	gvz	125	250	60	23.0	11.9	100	100
	HCR / 1.4529	125	160	60	15.6	11.9	100	200 ⁵⁾
	HCR / 1.4529	125	250	60	15.6	11.9	100	100 ⁵⁾
FHB dyn 16 x 125 V	gvz	130	160	60	23.0	17.0	100	200 ⁵⁾
	gvz	130	250	60	23.0	17.0	100	100
FHB dyn 20 x 170	gvz	170	220	100	28.4	17.0	80	80
FHB dyn 24 x 220	gvz	220	440	120	28.9	22.2	180	180 ⁵⁾

¹⁾ The design values of the cyclic fatigue loading apply for load cycles $\geq 5 \times 10^6$ in accordance with design method I - for unknown static lower load. If the static lower load is known and / or for lower number of load cycles higher load values are possible. The partial safety factors as regulated in the design standard are considered. As a single anchor counts e.g. an anchor with a spacing $s \geq 3 \times h_{ef}$. The given load values apply for anchorages in dry and wet concrete and temperatures in the base material up to 50 °C (resp. short-term up to 80 °C) and drill hole cleaning acc. to approval.

²⁾ For higher concrete strength classes up to C50/60 higher permissible loads may be possible, see approval. The concrete is assumed to be standard-reinforced.

³⁾ In the case of combinations of tensile loads, shear loads, bending moments with reduced or minimum spacing and edge distances (anchor groups) the design must be carried out in accordance with the provisions of the complete approval.

⁴⁾ Valid for pulsating loads. For alternating loads see approval.

⁵⁾ Without reduction of the tension and shear load. For details see approval.

Superbond dynamic FSB dyn

Dynamic fixation for FIS A and RG M with Superbond-System FSB

3



Pumps

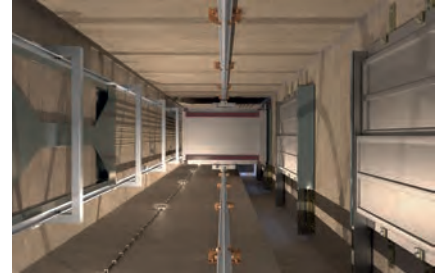

Guide rails for elevators

Applications

- Small road sign
- Promotional sign
- Guide rails for elevators
- Pumps
- Conveyor belts
- Gates and doors
- Machines, components exposed to vibration

Advantages

- The system is the first to offer lightweight, dynamic load specifications in an ETA for fischer FIS A 8.8 and RG M threaded rods using the filling set. The ETA covers zinc-plated steel in sizes M12 and M16, and stainless steel R in sizes M12 to M24. FIS A threaded rods must be mounted with FIS SB injection mortar and RG M threaded rods must be mounted with RSB mortar capsules or FIS SB injection

- mortar.
- Variable anchoring depth enables ideal adaption to the load and ensures optimised installation and material use.
- The version with RG M threaded rods and RSB capsules is ideal for accessories kits or applications with diamond drill holes.
- Approved threaded rods in stainless steel R can be used outdoors.

Certificates



ETA-12/0258, for cracked concrete
 ETA-13/0651, for post-installed rebar connection
 ETA-19/0501, for concrete under fatigue cyclic loading

Building materials

- Approved for:
- Concrete C20/25 to C50/60, cracked and non-cracked

Version

- Zinc-plated, steel grade 8.8
- Stainless steel R

Functioning

- Threaded rod FIS A in combination with injection mortar FIS SB is approved for pre-positioned and push-through installation.
- Threaded rod RG M in combination with the resin capsule RSB is approved for pre-positioned and push-through installation.
- The injection system ensures a full-surface bonding between the fixing element and wall of the drill hole and seals the drill hole.
- The filling disc ensures that the annular gap is filled seamlessly in pre-positioned installation, thereby ensuring reliable load transmission.
- The centering sleeve centres the threaded rod in the fixture, thus ensuring a safe load application.
- The lock nut prevents the hexagonal nut from becoming loose.

For use with

Dispenser page 189



Accessories page

194



Pre-positioned installation FIS A with filling disc

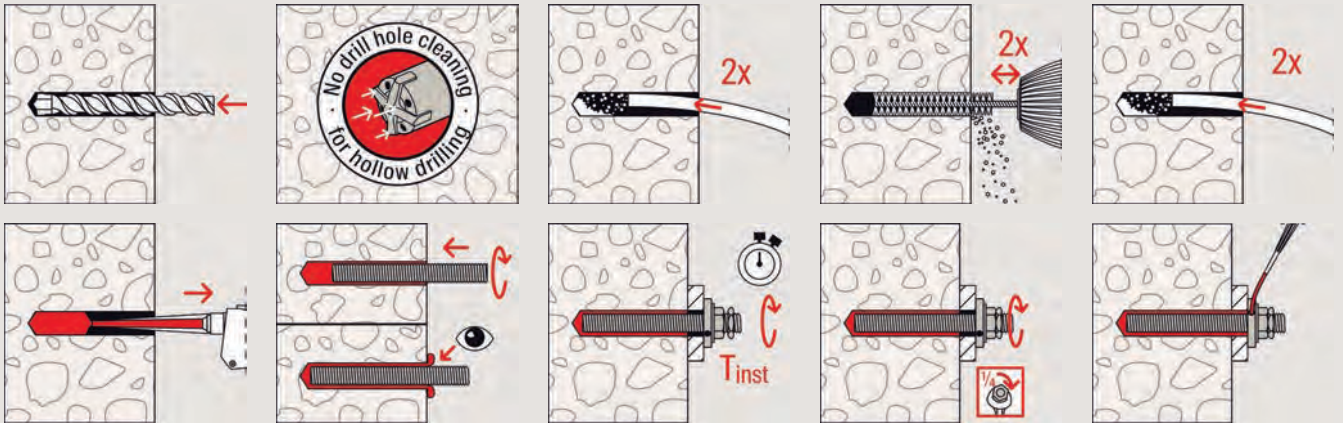

Push-through installation FIS A without filling disc

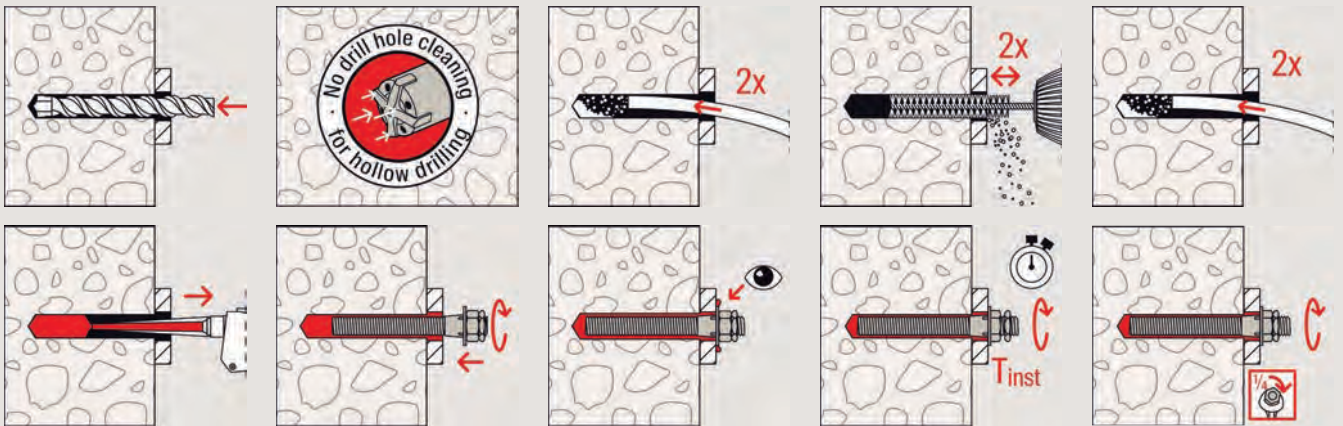

Push-through installation FIS A with filling disc

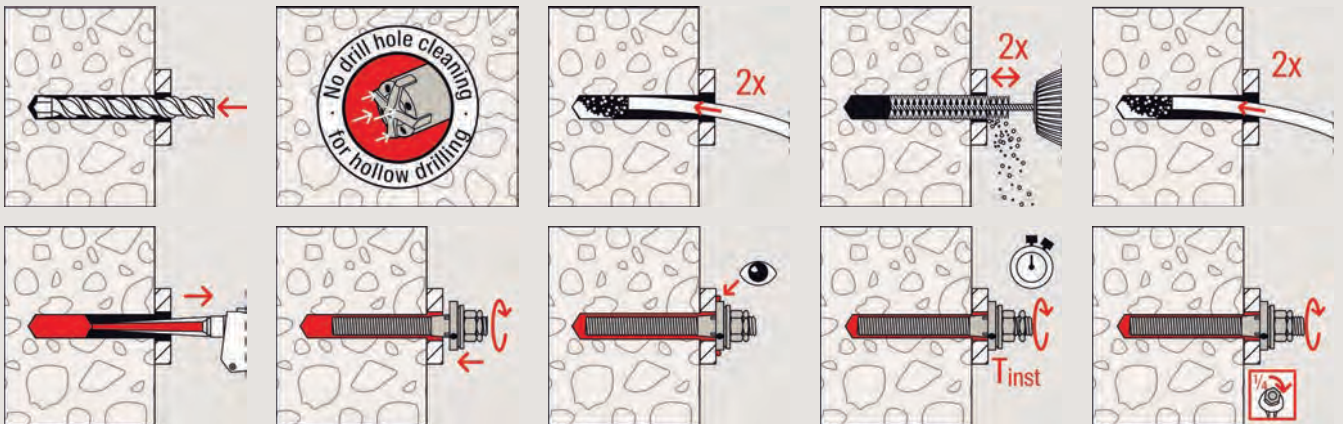

Pre-positioned installation RG M with capsule RSB (hammer drilling)

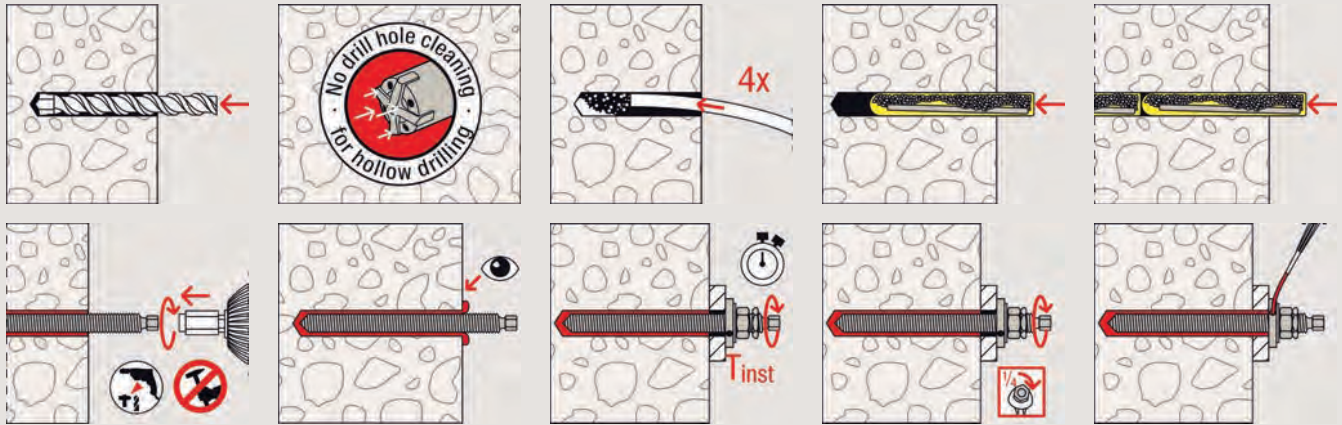

Push-through installation RG M with capsule RSB (hammer drilling)

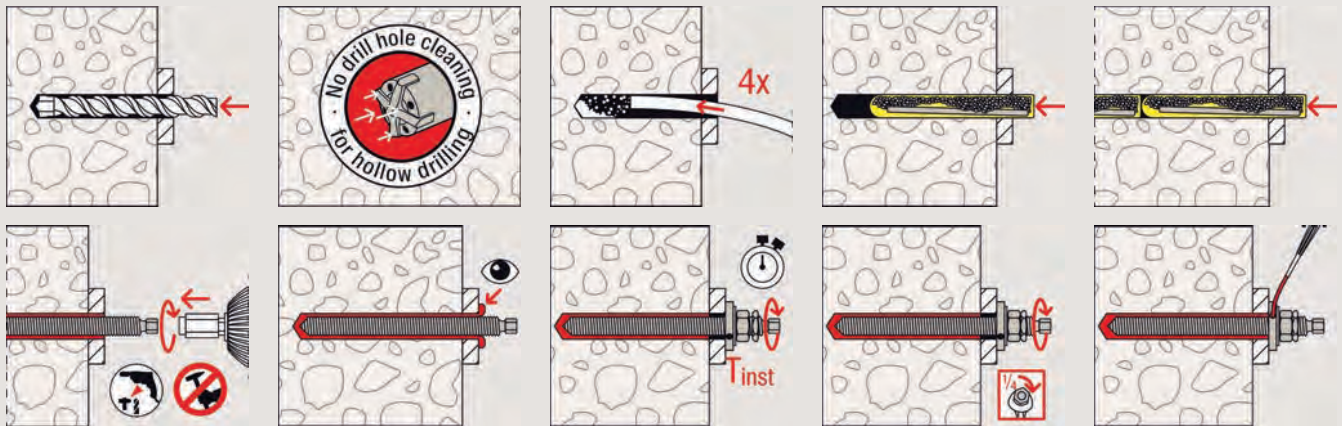

Pre-positioned installation RG M with capsule RSB (diamond drilling)

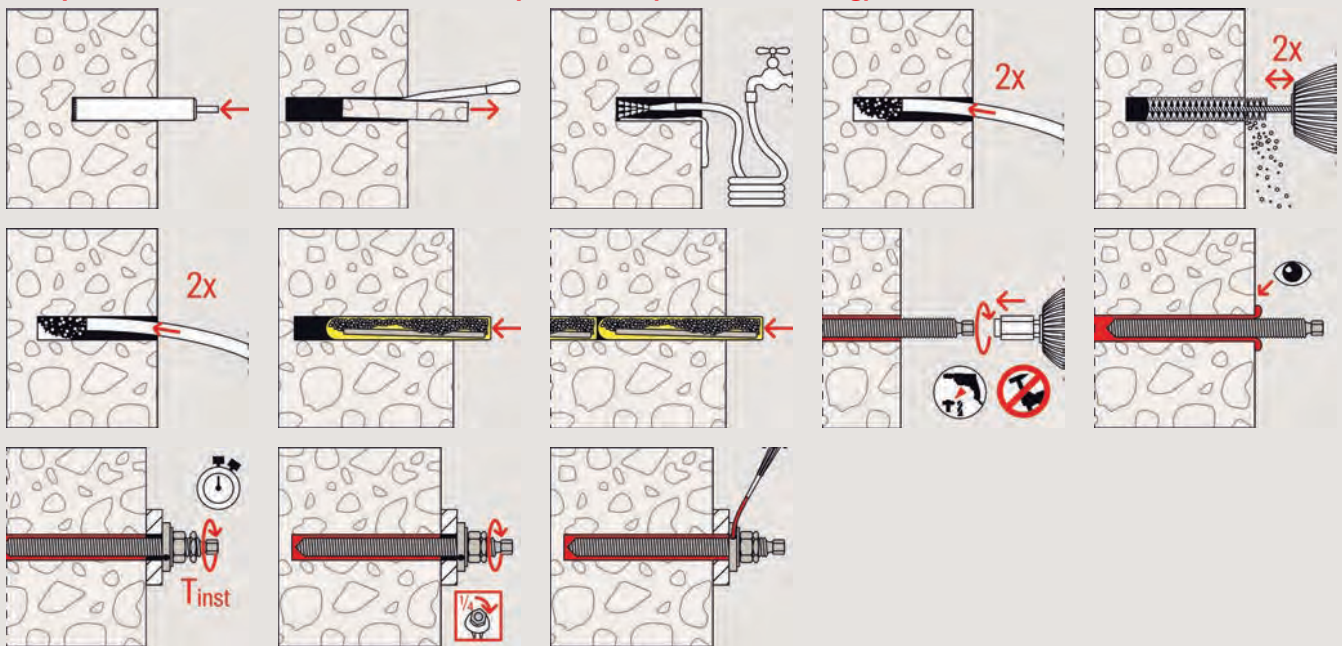

Push-through installation RG M with capsule RSB (diamond drilling)

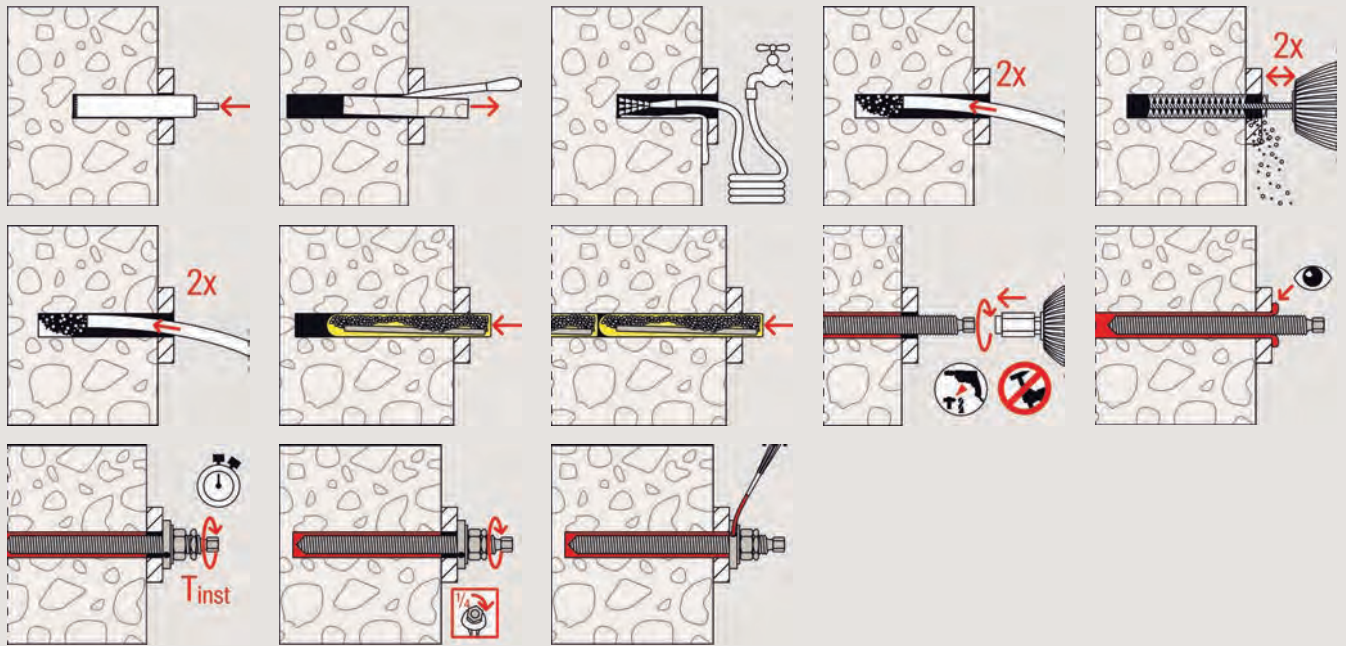

3

Technical data

Superbond dynamic FSB dyn



FIS SB 390 S

FIS MR Plus

Item	Item No.	Approval ETA	Languages on the cartridge	Scale unit	Contents	Sales unit [pcs]
FIS SB 390 S	519451	●	DE, FR, NL	180	1 cartridge 390 ml, 2 x FIS MR Plus	6
FIS SB 390 S	520557	●	DE, SL, SR, BG	180	1 cartridge 390 ml, 2 x FIS MR Plus	6
FIS SB 390 S	518831	●	EN, ES, PT	180	1 cartridge 390 ml, 2 x FIS MR Plus	6
FIS SB 390 S	519450	●	IT, DE, EN	180	1 cartridge 390 ml, 2 x FIS MR Plus	6
FIS SB 390 S	520559	●	DA, SV, NO, FI	180	1 cartridge 390 ml, 2 x FIS MR Plus	6
FIS SB 390 S	520555	●	CS, SK, RO	180	1 cartridge 390 ml, 2 x FIS MR Plus	6
FIS SB 390 S	520595	●	PL, RU, HU	180	1 cartridge 390 ml, 2 x FIS MR Plus	6
FIS SB 585 S	562065	●	FR, NL, DE	270	1 cartridge 585 ml + 2 x FIS UMR	6
FIS SB 585 S	519452	●	EN, ES, PT	270	1 cartridge 585 ml + 2 x FIS UMR	6
FIS SB 585 S	520526	●	IT, DE, EN	270	1 cartridge 585 ml + 2 x FIS UMR	6
FIS SB HIGH SPEED 390 S	523303	●	PL, RU, HU	180	1 cartridge 390 ml, 2 x FIS MR Plus	6
FIS MR Plus	545853	—	—	—	10 static mixer FIS MR Plus	10
FIS UMR	520593	—	—	—	10 static mixer for 585 ml and 1500 ml cartridges	10

Technical data

Superbond dynamic FSB dyn



FIS SB 390 S HWK big



FIS SB 390 S in bucket

Item	Item No.	Approval ETA	Languages on the cartridge	Contents	Sales unit [pcs]
FIS SB 390 S HWK big	540252	●	EN, ES, PT	20 cartridges 390 ml, 40 x FIS MR Plus	1
FIS SB 390 S HWK big	520573	●	IT, DE, EN	20 cartridges 390 ml, 40 x FIS MR Plus	1
FIS SB 390 S in bucket	540750	●	EN, ES, PT	18 cartridges 390 ml, 36 x FIS MR Plus	1

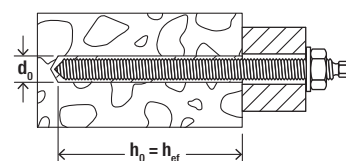

Technical data

Resin capsule RSB



RSB

Item	Item No.	Approval ETA	Drill diameter d_0 [mm]	Drill hole depth h_0 [mm]	Anchorage depth h_{ef} [mm]	Suitable for threaded rod	Sales unit [pcs]
RSB 12 mini	518822 ¹⁾	●	14	75 / 150	75 / 150	RG M 12	10
RSB 12	518823	●	14	110	110	RG M 12	10
RSB 16 mini	518824 ¹⁾	●	18	95 / 190	95 / 190	RG M 16	10
RSB 16	518825	●	18	125	125	RG M 16	10
RSB 16 E	518826	●	24	160	160	RG M 16 I	10
RSB 20	518827	●	25	170	170	RG M 20	10
RSB 20 E/24	518828	●	25/28/32	210	210	RG M 20 / RG M 22	5

¹⁾ use 2 x RSB mini in a row for larger anchoring depth

Curing times

FSB dyn Temperature in anchoring base [°C]	Maximum processing time FIS SB		Minimum curing time FIS SB		Minimum curing time FIS SB High Speed		Minimum curing time RSB	
	t_{work} [Min.]	t_{work} [Min.]	t_{cure} [hrs.]	[min.]	t_{cure} [hrs.]	[min.]	t_{cure} [hrs.]	[min.]
-30 - -20	-	-	-	-	-	-	120	-
>-20 - -15	-	60	-	-	24	-	48	-
>-15 - -10	60	30	36	-	8	-	30	-
>-10 - -5	30	15	24	-	3	-	16	-
>-5 - 0	20	10	8	-	2	-	10	-
>0 - +5	13	5	4	-	1	-	-	45
>+5 - +10	9	3	2	-	-	45	-	30
>+10 - +20	5	2	1	-	-	30	-	20
>+20 - +30	4	1	-	45	-	15	-	5
> +30 - +40	2	-	-	30	-	-	-	3

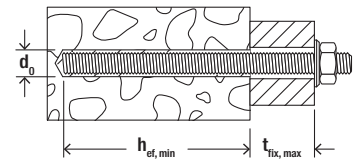

Technical data in concrete

Threaded rod FIS A



FIS A

Item	Zinc plated, steel grade 8.8	Stainless steel	Approval	Drill hole diameter	Min. / max. anchorage depth	Min. / max. usable length	Min. / max. filling quantity	Sales unit
	Item No.	Item No.	ETA	d_0 [mm]	[mm]	[mm]	[scale units]	[pcs]
FIS A M 12 x 120	519397	044974	●	14	70 / 83	12 / 25	3 / 4	10
FIS A M 12 x 140	—	090450	●	14	70 / 103	12 / 45	3 / 5	10
FIS A M 12 x 140	519398	—	●	14	70 / 103	71 / 103	3 / 5	10
FIS A M 12 x 160	517937	090451	●	14	70 / 123	12 / 65	3 / 6	10
FIS A M 12 x 180	519399	090452	●	14	70 / 143	12 / 85	3 / 6	10
FIS A M 12 x 200	517938	—	●	14	70 / 163	12 / 105	3 / 7	10
FIS A M 12 x 210	—	090453	●	14	70 / 173	12 / 115	3 / 8	10
FIS A M 12 x 260	—	090454	●	14	70 / 223	12 / 165	3 / 10	10
FIS A M 12 x 280	—	547703	●	14	70 / 243	12 / 85	3 / 10	10
FIS A M 16 x 130	519400	044975	●	18	80 / 84	16 / 20	5 / 5	10
FIS A M 16 x 175	519401	090455	●	18	80 / 129	16 / 65	5 / 8	10
FIS A M 16 x 200	517939	090456	●	18	80 / 154	16 / 90	5 / 9	10
FIS A M 16 x 250	517940	090457	●	18	80 / 204	16 / 140	5 / 12	10
FIS A M 16 x 300	—	090458	●	18	80 / 254	16 / 190	5 / 15	10
FIS A M 20 x 245	—	090459	●	24	90 / 189	20 / 119	11 / 23	10
FIS A M 20 x 290	—	090460	●	24	90 / 234	20 / 164	11 / 29	10
FIS A M 24 x 290	—	090461	●	28	96 / 223	24 / 151	14 / 32	5
FIS A M 24 x 380	—	090462	●	28	96 / 313	24 / 200	14 / 45	5

3

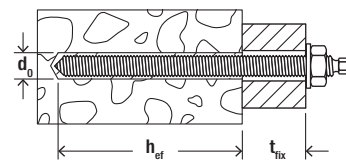

Technical data in concrete

Threaded rod RG M



RG M

3

Item	Stainless steel	Approval	Drill hole diameter d_0 [mm]	Anchorage depth h_{ef} [mm]	Usable length t_{fix} [mm]	Fits capsule RSB	Sales unit
	Item No.						ETA
RG M 12 x 120	535011	●	14	75	12-13	1 x RSB 12 mini	10
RG M 12 x 160	050265	●	14	75 / 110	12-53 / 12-18	1 x RSB 12 mini 1 x RSB 12	10
RG M 12 x 180	512249	●	14	75 / 110	12-73 / 12-38	1 x RSB 12 mini 1 x RSB 12 2 x RSB 12 mini	10
RG M 12 x 200	050576	●	14	75 / 110	12-93 / 12-58	1 x RSB 12 mini 1 x RSB 12 2 x RSB 12 mini	10
RG M 12 x 220	050297	●	14	75 / 110 / 150	12-113 / 12-78 / 12-38	1 x RSB 12 mini 1 x RSB 12 2 x RSB 12 mini	10
RG M 12 x 250	095702	●	14	75 / 110 / 150	12-143 / 12-108 / 12-68	1 x RSB 12 mini 1 x RSB 12 2 x RSB 12 mini	10
RG M 12 x 300	095705	●	14	75 / 110 / 150	12-193 / 12-158 / 12-118	1 x RSB 12 mini 1 x RSB 12 2 x RSB 12 mini	10
RG M 12 x 380	095710 ¹⁾	●	14	75 / 110 / 150	12-200 / 12-200 / 12-198	1 x RSB 12 mini 1 x RSB 12 2 x RSB 12 mini	10
RG M 16 x 165	095704	●	18	95	16-32	1 x RSB 16 mini 1 x RSB 16	10
RG M 16 x 190	050266	●	18	95 / 125	16-57 / 16-27	1 x RSB 16 mini 1 x RSB 16	10
RG M 16 x 250	050298	●	18	95 / 125 / 190	16-117 / 16-87 / 16-22	1 x RSB 16 mini 1 x RSB 16 2 x RSB 16 mini	10
RG M 16 x 300	050299	●	18	95 / 125 / 190	16-167 / 16-137 / 16-72	1 x RSB 16 mini 1 x RSB 16 2 x RSB 16 mini	10
RG M 16 x 380	095712 ¹⁾	●	18	95 / 125 / 190	16-200 / 16-200 / 16-152	1 x RSB 16 mini 1 x RSB 16 2 x RSB 16 mini	10
RG M 16 x 500	095713 ¹⁾	●	18	95 / 125 / 190	16-200 / 16-200 / 16-200	1 x RSB 16 mini 1 x RSB 16 2 x RSB 16 mini	10
RG M 20 x 260	050267	●	25	170	20-47	1 x RSB 20 1 x RSB 20 E / 24	10
RG M 20 x 350	095706	●	25	170 / 210	20-137 / 20-97	1 x RSB 20 1 x RSB 20 E / 24	10
RG M 24 x 300	050268 ¹⁾	●	28	210	24-47	1 x RSB 20 E / 24	10
RG M 24 x 400	095715 ¹⁾	●	28	210	24-147	1 x RSB 20 E / 24	10

1) Straight cut, additional setting tool required

- max. usable length at dynamic application 200 mm.

- Information about anchorage depth and usable length refer to the installation with filling disc. While using standard washers for the sizes M20 + M24 other values are valid.

Accessories

Filling set



Filling sets for subsequent filling of the annular gap

Item	Item No.	Match	Sales unit [pcs]
Filling set M 12	537218	FIS A/RG M 12	10
Filling set M 16	537219	FIS A/RG M 16	10
Filling set M 12 R	557875	FIS A/RG M 12 R	10
Filling set M 16 R	557876	FIS A/RG M 16 R	10
Filling set M 20 R	557877	FIS A/RG M 20 R	10
Filling set M 24 R	557878	FIS A/RG M 24 R	10
Filling set M 20 R push-through	557879	FIS A/RG M 20 R	10
Filling set M 24 R push-through	557880	FIS A/RG M 24 R	10

Loads

Superbond dynamic with Superbond mortar FIS SB and threaded rod FIS A resp. RG M

Design values for cyclic fatigue loading¹⁾ of a single anchor normal concrete of strength class C20/25²⁾. For the design the complete current assessment ETA-19/0501 has to be considered.

Type	Material/surface	Effective anchorage depth h_{ef} [mm]	Minimum member thickness h_{min} [mm]	Installation torque T_{inst} [Nm]	Cracked concrete				Non-cracked concrete			
					Design values of tension ($\Delta N_{Ed,max}$) and shear loads ($\Delta V_{Ed,max}$); minimum spacing (s_{min}) and edge distances (c_{min}) with reduced loads				Design values of tension ($\Delta N_{Ed,max}$) and shear loads ($\Delta V_{Ed,max}$); minimum spacing (s_{min}) and edge distances (c_{min}) with reduced loads			
					$\Delta N_{Ed,max}^{3)}$ [kN]	$\Delta V_{Ed,max}^{3)}$ [kN]	$s_{min}^{3)}$ [mm]	$c_{min}^{3)}$ [mm]	$\Delta N_{Ed,max}^{3)}$ [kN]	$\Delta V_{Ed,max}^{3)}$ [kN]	$s_{min}^{3)}$ [mm]	$c_{min}^{3)}$ [mm]
FIS A M 12	8.8	70	100	40	3.0	2.0	55	55	4.5	2.0	55	55
	8.8	110	140	40	4.5	2.0	55	55	4.5	2.0	55	55
	8.8	240	270	40	4.5	2.0	55	55	4.5	2.0	55	55
	R-70	70	100	40	3.0	2.7	55	55	4.8	2.7	55	55
	R-70	110	140	40	4.9	2.7	55	55	4.9	2.7	55	55
	R-70	240	270	40	4.9	2.7	55	55	4.9	2.7	55	55
FIS A M 16	8.8	80	120	60	4.8	3.7	65	65	8.4	3.7	65	65
	8.8	125	170	60	8.4	3.7	65	65	8.4	3.7	65	65
	8.8	320	360	60	8.4	3.7	65	65	8.4	3.7	65	65
	R-70	80	120	60	4.8	4.9	65	65	8.4	4.9	65	65
	R-70	125	170	60	8.8	4.9	65	65	9.2	4.9	65	65
	R-70	320	360	60	9.2	4.9	65	65	9.2	4.9	65	65
FIS A M 20	R-70	90	140	120	7.1	7.6	85	85	12.4	7.6	85	85
	R-70	170	220	120	14.3	7.6	85	85	14.3	7.6	85	85
	R-70	400	450	120	14.3	7.6	85	85	14.3	7.6	85	85
FIS A M 24	R-70	96	160	150	7.4	11.0	105	105	11.8	11.0	105	105
	R-70	210	270	150	20.2	11.0	105	105	20.6	11.0	105	105
	R-70	480	540	150	20.6	11.0	105	105	20.6	11.0	105	105

¹⁾ The design values of the cyclic fatigue loading apply for load cycles $> 10^6$ in accordance with design method I acc. to TR061 - for unknown static lower load. If the static lower load is known and / or for lower number of load cycles higher load values are possible. The partial safety factors as regulated in the design standard are considered. As a single anchor counts e.g. an anchor with a spacing $s \geq 3 \times h_{ef}$. The given load values apply for anchorages in dry and wet concrete and temperatures in the base material up to 50 °C (resp. short-term up to 80 °C) and drill hole cleaning acc. to assessment.

²⁾ For higher concrete strength classes up to C50/60 higher permissible loads may be possible, see assessment. The concrete is assumed to be standard-reinforced.

³⁾ In the case of combinations of tension loads, shear loads, bending moments with reduced or minimum spacing and edge distances (anchor groups) the design must be carried out in accordance with the provisions of the complete assessment.

Loads

Superbond dynamic with Superbond capsule RSB and threaded rod RG M

Design values for cyclic fatigue loading¹⁾ of a single anchor normal concrete of strength class C20/25²⁾.
For the design the complete current assessment ETA-19/0501 has to be considered.

Type	Material/ surface	Effective anchorage depth h_{ef} [mm]	Minimum member thickness h_{min} [mm]	Installation torque T_{inst} [Nm]	Cracked concrete				Non-cracked concrete			
					Design values of tension ($\Delta N_{Ed,max}$) and shear loads ($\Delta V_{Ed,max}$); minimum spacing (s_{min}) and edge distances (c_{min}) with reduced loads				Design values of tension ($\Delta N_{Ed,max}$) and shear loads ($\Delta V_{Ed,max}$); minimum spacing (s_{min}) and edge distances (c_{min}) with reduced loads			
					$\Delta N_{Ed,max}^{3)}$ [kN]	$\Delta V_{Ed,max}^{3)}$ [kN]	$s_{min}^{3)}$ [mm]	$c_{min}^{3)}$ [mm]	$\Delta N_{Ed,max}^{3)}$ [kN]	$\Delta V_{Ed,max}^{3)}$ [kN]	$s_{min}^{3)}$ [mm]	$c_{min}^{3)}$ [mm]
RG M 12	8.8	75	110	40	3.3	2.0	55	55	4.5	2.0	55	55
	8.8	110	140	40	4.5	2.0	55	55	4.5	2.0	55	55
	8.8	150	180	40	4.5	2.0	55	55	4.5	2.0	55	55
	R-70	75	110	40	3.3	2.7	55	55	4.9	2.7	55	55
	R-70	110	140	40	4.9	2.7	55	55	4.9	2.7	55	55
	R-70	150	180	40	4.9	2.7	55	55	4.9	2.7	55	55
RG M 16	8.8	95	140	60	6.2	3.7	65	65	8.4	3.7	65	65
	8.8	125	170	60	8.4	3.7	65	65	8.4	3.7	65	65
	8.8	190	230	60	8.4	3.7	65	65	8.4	3.7	65	65
	R-70	95	140	60	6.2	4.9	65	65	9.2	4.9	65	65
	R-70	125	170	60	8.8	4.9	65	65	9.2	4.9	65	65
	R-70	190	230	60	9.2	4.9	65	65	9.2	4.9	65	65
RG M 20	R-70	170	220	120	14.3	7.6	85	85	14.3	7.6	85	85
	R-70	210	260	120	14.3	7.6	85	85	14.3	7.6	85	85
RG M 24	R-70	210	270	150	20.2	11.0	105	105	20.6	11.0	105	105

¹⁾ The design values of the cyclic fatigue loading apply for load cycles $> 10^8$ in accordance with design method I acc. to TR061 - for unknown static lower load. If the static lower load is known and / or for lower number of load cycles higher load values are possible. The partial safety factors as regulated in the design standard are considered. As a single anchor counts e.g. an anchor with a spacing $s \geq 3 \times h_{ef}$. The given load values apply for anchorages in dry and wet concrete and temperatures in the base material up to 50 °C (resp. short-term up to 80 °C) and drill hole cleaning acc. to assessment.

²⁾ For higher concrete strength classes up to C50/60 higher permissible loads may be possible, see assessment. The concrete is assumed to be standard-reinforced.

³⁾ In the case of combinations of tension loads, shear loads, bending moments with reduced or minimum spacing and edge distances (anchor groups) the design must be carried out in accordance with the provisions of the complete assessment.

Dynamic anchor FDA

The dynamic push-through anchor for an economical serial installation at medium load level



Platform lifts

Applications

- hydraulic ramps
- Conveyor belts
- Industrial robots
- cooperation robots and -parts
- Guide rails for elevators

Certificates



ETA-20/0206

Advantages

- Medium load level for a variety of applications.
- Pre-assembled anchor rod for fast installation.
- Assessed safety acc. to ETA for endless numbers of load cycles.
- Easy push-through installation leads to

cost effectiveness – especially for serial installations.

- Tight assortment with the size.
- Less spacings and edge distances.
- Drill holes are sealed.

Building materials

- Concrete C20/25 to C50/60, cracked and non-cracked

Versions

- Zinc-plated steel

Functioning

- The injection system suitable for tensile zones consists of the fischer dynamic anchor rod FDA-A dyn and the injection mortar FIS HB.
- FDA is approved for push-through installation.
- Extruding the mortar causes the two components to be mixed and activated in the static mixer.
- The mortar bonds the entire surface of the anchor rod with the drill hole wall and seals the drill hole.
- The centring sleeve centres the anchor in the fixture, thus ensuring a safe load application.
- During the setting process, the injection mortar FIS HB fills the annular gap in the fixture, and ensures optimum load distribution. This allows for the absorption of dynamic alternating loads.

Installation in concrete with FIS HB and FDA

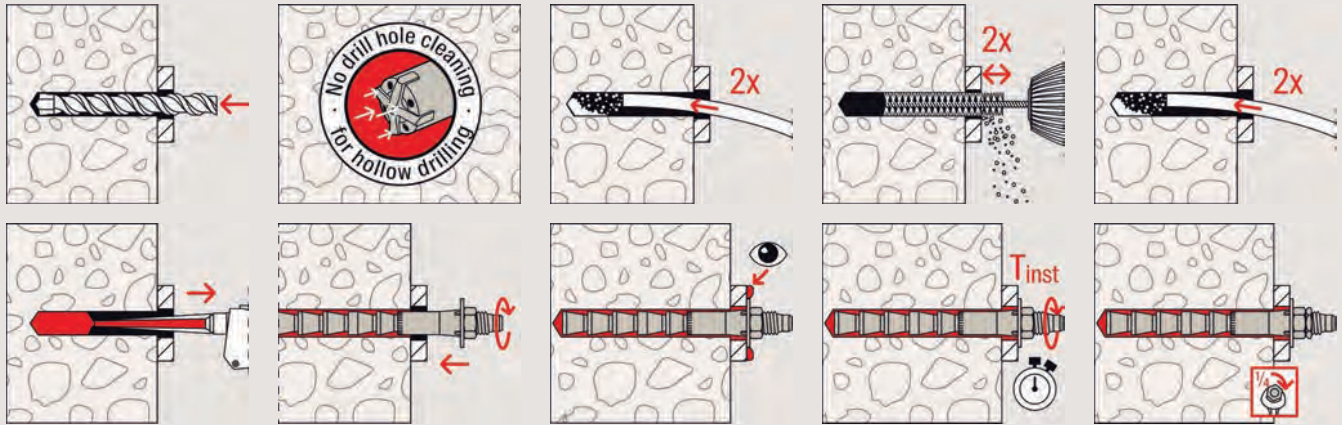

3

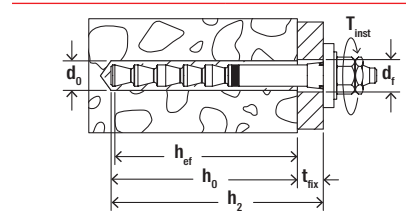

Technical data

Dynamic anchor FDA



FDA

Item	Item No. gvz	Approval ETA	Drill hole diameter	Drill hole diameter in fixture	Anchorage depth	Min. - max. usable length	Min. drill hole depth for through fixings	Width across nut	Sales unit
			d_0 [mm]	d_i [Ø mm]	h_{ef} [mm]	t_{fix} [mm]	h_2 [mm]	SW [mm]	[pcs]
FDA-A 12 x 100/25 gvz	536943	●	14	15	100	12 - 25	130	19	10
FDA-A 12 x 100/50 gvz	536944	●	14	15	100	12 - 50	155	19	10
FDA-A 16 x 125/25 gvz	536945	●	18	19	125	16 - 25	155	24	10
FDA-A 16 x 125/50 gvz	536946	●	18	19	125	16 - 50	180	24	10
FDA-A 16 x 125/80 gvz	558966	●	18	19	125	16 - 80	210	24	10

Loads

Dynamic-Anchor FDA

Design values for cyclic fatigue loading¹⁾ of a single anchor normal concrete of strength class C20/25²⁾.
For the design the complete current assessment ETA-20/0206 has to be considered.

Type	Material fixing element	Effective anchorage depth h_{ef} [mm]	Minimum member thickness h_{min} [mm]	Installation torque T_{inst} [Nm]	Cracked and non-cracked concrete			
					Design values of tension ($\Delta N_{Ed,max}$) and shear loads ($\Delta V_{Ed,max}$); minimum spacing (s_{min}) and edge distances (c_{min}) with reduced loads			
					$\Delta N_{Ed,max}$ ³⁾ [kN]	$\Delta V_{Ed,max}$ ³⁾⁴⁾ [kN]	s_{min} ⁴⁾ [mm]	c_{min} ⁴⁾ [mm]
FDA 12 x 100	gvz	100	130	40	10.8	5.0	100	200 ⁵⁾
	gvz	100	200	40	10.8	5.0	100	100 ⁵⁾
FDA 16 x 125	gvz	125	160	60	18.5	9.1	100	200 ⁵⁾
	gvz	125	250	60	18.5	9.1	100	100

¹⁾ The design values of the cyclic fatigue loading apply for load cycles $\geq 5 \times 10^6$ in accordance with design method I acc. to TR061 - for unknown static lower load. If the static lower load is known and / or for lower number of load cycles higher load values are possible. The partial safety factors as regulated in the design standard are considered. As a single anchor counts e.g. an anchor with a spacing $s \geq 3 \times h_{ef}$. The given load values apply for anchorages in dry and wet concrete and temperatures in the base material up to 50 °C (resp. short-term up to 80 °C) and drill hole cleaning acc. to assessment.

²⁾ For higher concrete strength classes up to C50/60 higher permissible loads may be possible, see assessment. The concrete is assumed to be standard-reinforced.

³⁾ In the case of combinations of tension loads, shear loads, bending moments with reduced or minimum spacing and edge distances (anchor groups) the design must be carried out in accordance with the provisions of the complete assessment.

⁴⁾ Valid for pulsating loads. For alternating loads see assessment.

⁵⁾ Without reduction of the tension and shear load. Details see assessment.

Post-installed rebar connections

Professional rebar connections

3

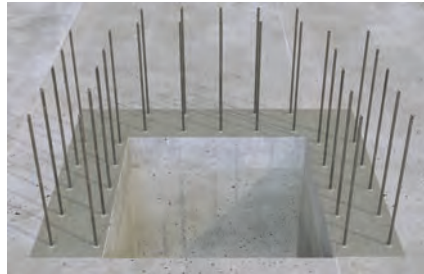

Post-installed rebar connections



Post-installed rebar connections

Applications

- Post-installed concrete steel bars, e.g. for overlap connections, end anchorings, starter bars, crack stitching etc.
- Rebar anchor FRA
- Concrete-Concrete Shear Connector FCC

Advantages

- The injection mortars FIS V Plus, FIS V and FIS VS LOW SPEED allow for rebar connections from Ø8 to 28 mm, whilst injection mortar FIS EM Plus allows for rebar connections up to Ø40 mm to be carried out. This offers maximum flexibility.
- The injection mortar FIS SB allows the user for realizing rebar connections from Ø 8 to 32 mm in combination with a simple and thus user-friendly cleaning of the drill hole.
- FIS EM Plus also allows for the execution of rebar connections in diamond-drilled holes without additional roughening of

the drillhole.

- The fischer rebar anchor FRA with connecting thread in stainless steel R fully utilises the load-bearing capacity of the concrete. This means that extremely high tensile loads can be introduced into the base material.
- Accessories in line with building site requirements, such as injection adapters and extension tubes, ensure rapid progress.
- The FIS rebar case contains all of the individual components required, thus ensuring a convenient installation.

Certificates



ETA-08/0266, Post-installed rebar connections
ETA-15/0539, Post-installed rebar connections
ETA-20/0728, Post-installed rebar connections
ETA-17/1056, Post-installed rebar connections

Building materials

Approved for:

- Concrete C12/15 to C50/60, cracked and non-cracked

Functioning

- Anchoring as with cast-in reinforcement bars in line with Eurocode 2 and DIN 1045-1.
- The mortar is extruded bubble free into the drill hole using the injection adapter. The geometry causes a build-up of pressure in the drill hole, which pushes the injection adapter and extension tube automatically out of the drill hole.
- The mortar bonds the entire surface of the reinforcement bar with the drill hole wall.
- A special certification is necessary for installation according to approval in Germany. The fischer Academy offers the relevant training courses.

Installation in concrete with FIS EM Plus in hammer drilled holes

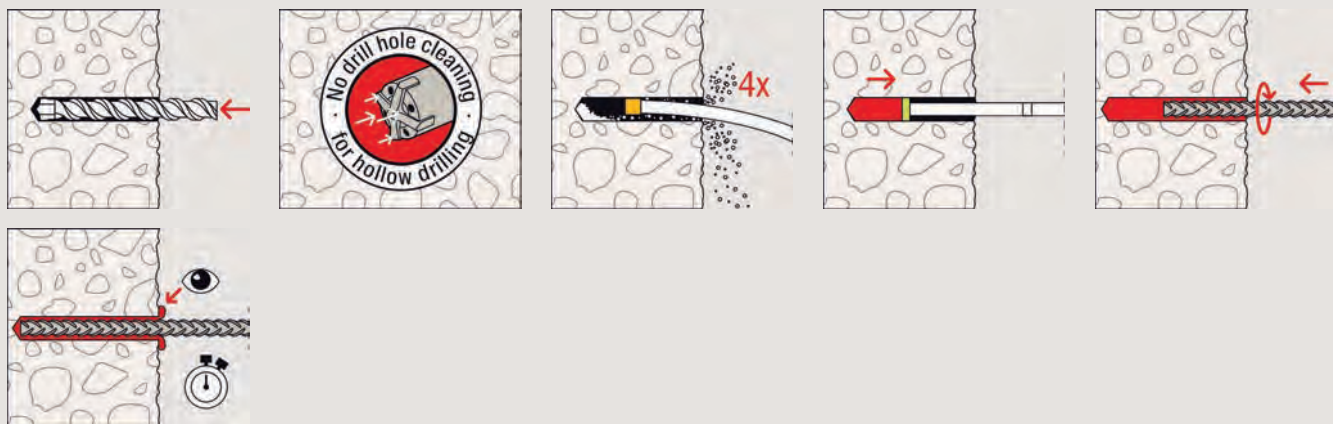

3

Installation in concrete with FIS EM Plus in diamond drilled holes

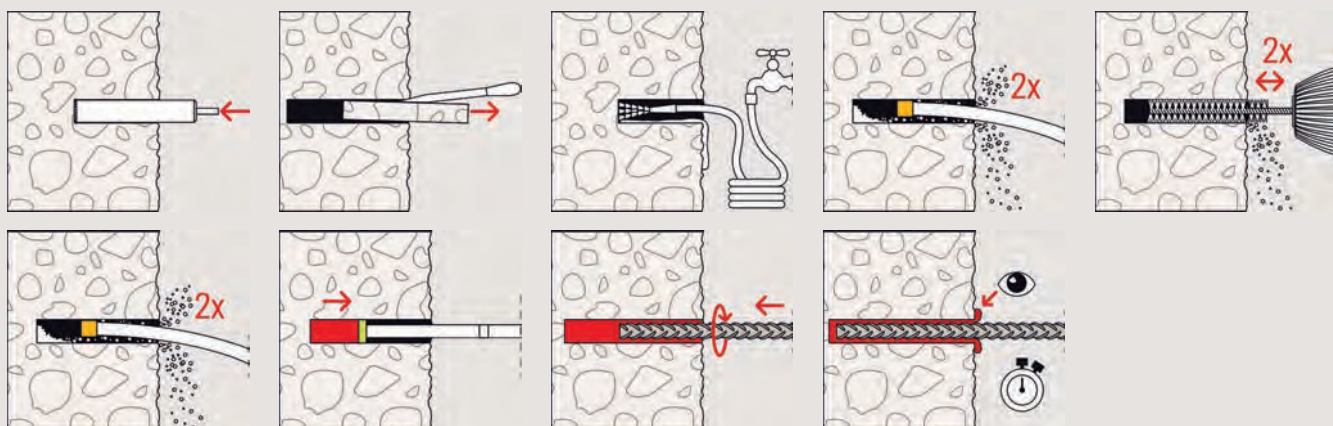

Installation in concrete with FIS SB in hammer drilled holes

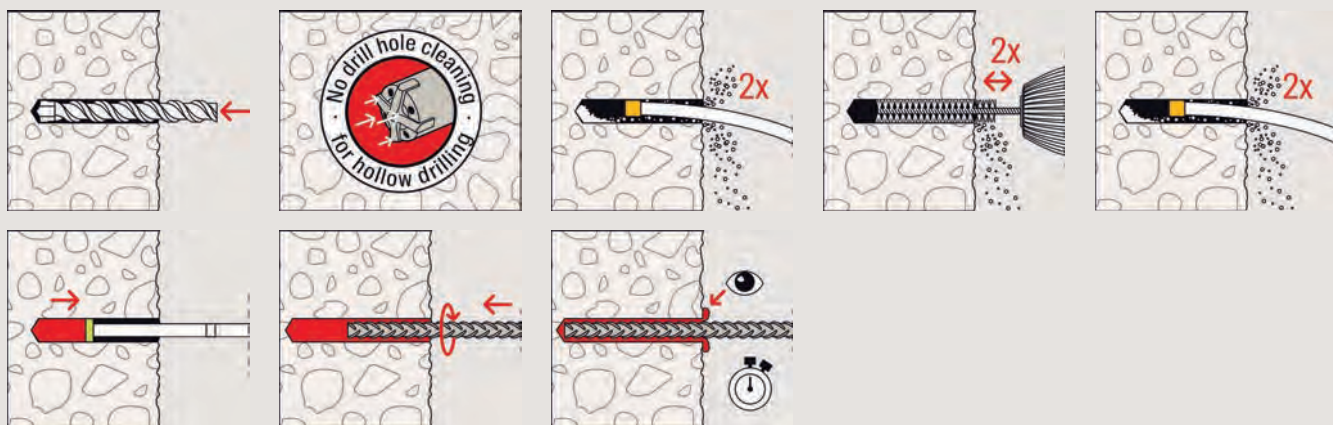

Installation in concrete with FIS V Plus and FIS V in hammer drilled holes

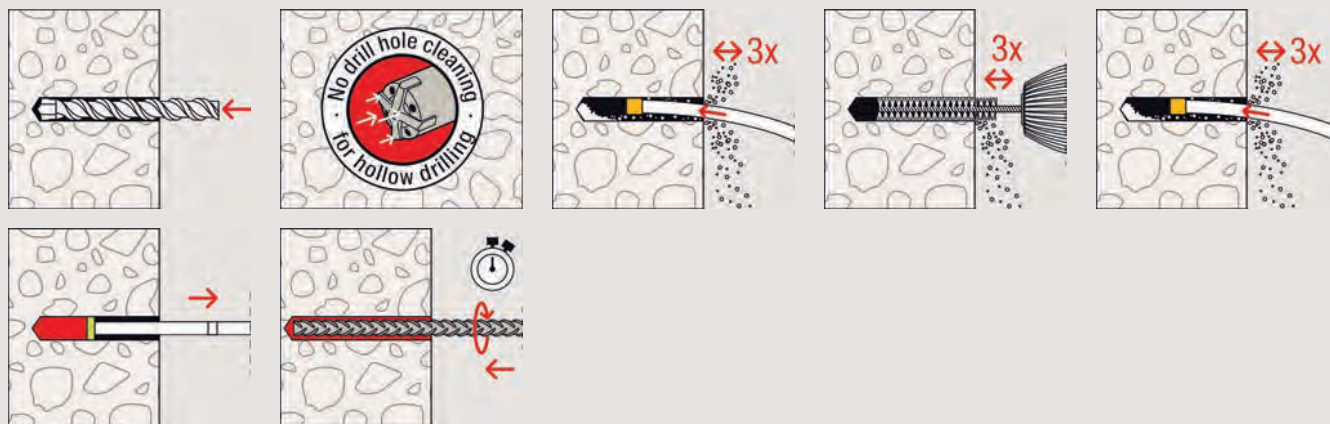

3

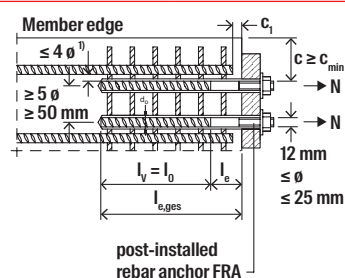

¹) If the clear distance of the lapped bars is larger than 4 x φ, EC2 must be applied.

Technical data

Rebar anchor FRA

FRA

Item	Combination of materials	Approval	Total length	Max. fixing thickness	Drill hole	Fill quantity	Sales unit
	Item No.		l [mm]	t _{fix} [mm]	d ₀ [Ø mm]		
FRA 12/900 M12-60	505529 ¹⁾	●	975	60	16	50	8
FRA 16/1100 M16-60	505533 ¹⁾	●	1180	60	20	81	8
FRA 20/1400 M20-60	505534 ¹⁾	●	1485	60	25	160	4

1) Further dimensions up to max. 1800 mm total length on request.

Technical data

FIS-Rebar case



FIS-Rebar Case for reinforcement connection

Item	Item No.	Approval	Contents	Sales unit [pcs]
		ETA		
FIS-Rebar case D	505941	●	8 x Cleaning brush BSB, 5 x Extensions for cleaning brushes à 40 cm, 1 x SDS Chuck with internal thread M 8, 24 x Injection adapter, 1 x Cleaning hose complete, 1 x Brush control template, 8 x Cleaning nozzle, 1 x Marker tape, 1 x Digital thermometer, 1 x Protective goggles, 1 x Installation instructions (german), 10 x Installation report, 2 x Flat spanner SW 7 and the relevant approvals	1
FIS-Rebar case Int	505942	●	8 x Cleaning brush BSB, 5 x Extensions for cleaning brushes à 40 cm, 1 x SDS Chuck with internal thread M 8, 24 x Injection adapter, 1 x Cleaning hose complete, 1 x Brush control template, 8 x Cleaning nozzle, 1 x Marker tape, 1 x Digital thermometer, 1 x Protective goggles, 1 x Installation instructions (german, english, french, italian, spanish), 10 x Installation report, 2 x Flat spanner SW 7 and the relevant approvals	1

Accessories

Cleaning brushes



Cleaning brush with thread
M 8

Item	Item No.	Colour	Length [mm]	Sales unit [pcs]
BSB for drill-Ø 12 mm	001490	white	180	1
BSB for drill-Ø 14 mm	001491	blue	180	1
BSB for drill-Ø 16 mm	001492	red	180	1
BSB for drill-Ø 18 mm	001493	yellow	180	1
BSB for drill-Ø 20 mm	001494	green	180	1
BSB for drill-Ø 25 mm	001495	black	180	1
BSB for drill-Ø 30 mm	090063	grey	180	1
BSB for drill-Ø 35 mm	090071	brown	180	1
BSB for drill-Ø 40 mm	505061	—	180	1
BSB for drill-Ø 45 mm	506254	—	180	1
BSB for drill-Ø 55 mm	505062	—	180	1
SDS Chuck	530332	—	—	1
FIS brush extension	508791	—	420	1

Accessories

Injection adapter



Injection adapter for drill Ø
12 - 25 mm

Injection adapter for drill Ø
30 - 55 mm

Extension tube

Item	Item No.	Colour	Length [mm]	Sales unit [pcs]
Injection-adapter (Ø 9) for drill-Ø 12 mm	001497	ecru	—	10
Injection-adapter (Ø 9) for drill-Ø 14 mm	001498	blue	—	10
Injection-adapter (Ø 9) for drill-Ø 16 mm	001499	red	—	10
Injection-adapter (Ø 9) for drill-Ø 18 mm	001483	yellow	—	10
Injection-adapter (Ø 9) for drill-Ø 20 mm	001506	green	—	10
Injection-adapter (Ø 9) for drill-Ø 25 mm	001507	black	—	10
Injection-adapter (Ø 9) for drill-Ø 30 mm	090689	grey	—	10
Injection-adapter (Ø 9) for drill-Ø 35 mm	090699	brown	—	10
Injection-adapter (Ø 9) for drill-Ø 40 mm	505077	red	—	10
Injection-adapter (Ø 9) for drill-Ø 45 mm	508909	yellow	—	10
Injection-adapter (Ø 9) for drill-Ø 55 mm	505078	ecru	—	10
Injection-adapter (Ø 15) for drill-Ø 20 mm	001508	green	—	10
Injection-adapter (Ø 15) for drill-Ø 25 mm	001509	black	—	10
Injection-adapter (Ø 15) for drill-Ø 30 mm	090700	grey	—	10
Injection-adapter (Ø 15) for drill-Ø 35 mm	090701	brown	—	10
Injection-adapter (Ø 15) for drill-Ø 40 mm	505079	red	—	10
Injection-adapter (Ø 15) for drill-Ø 45 mm	508910	yellow	—	10
Injection-adapter (Ø 15) for drill-Ø 55 mm	505080	ecru	—	10
FIS Extension tube	048983	—	1000	10
FIS EXT Ø 15	530800	transparent	10000	1

Accessories

Drilling aid / scrabbling tool



Drilling aid

SDS-max scrabbling tool

Item	Item No.	Match	Dimensions [mm]	Sales unit [pcs]
Drilling aid 3pcs.	090819 ¹⁾	—	—	1
Scrabbling tool	001253	Chuck type SDS max	45 x 240	1

1) delivery on request

Accessories

Compressed air nozzles



Compressed air nozzle

Item	Item No.	Match	Sales unit [pcs]
Compressed air nozzle D12-D15	511956	Drill diameter Ø 12 - 15 mm	2
Compressed air nozzle D16-D19	511957	Drill diameter Ø 16 - 19 mm	2
Compressed air nozzle D20-D25	511958	Drill diameter Ø 20 - 25 mm	2
Compressed air nozzle D30-D35	511959	Drill diameter Ø 30 - 35 mm	2
Compressed air nozzle D40-D55	511960 ¹⁾	Drill diameter Ø 40 - 45 mm	2

¹⁾ Delivery time on request.

Loads

Rebar anchor FRA with injection systems FIS EM Plus, FIS SB, FIS V Plus und FIS VS Plus LOW SPEED in accordance with rebar theory

Design resistances and permissible loads^{1) 2)} of single, post-installed Rebar anchor in cracked or non-cracked normal concrete of the strength class C20/25³⁾.

Type	Basic value for anchorage length $l_{b,reqd}$ ⁴⁾ [mm]	Maximum anchorage depth $l_{v,max}$ [mm]	Maximum embedment depth $l_{e,ges,max}$ [mm]	Maximum installation torque T_{inst} [Nm]	Maximum design resistance for axial tension load $N_{Rd,s}$ ⁵⁾ [kN]	Maximum permissible tension load $N_{zul,s}$ ⁵⁾ [kN]
FRA 12/900 M12	567	800	900	≤ 50	49.2	35.1
FRA 16/1100 M16	756	1000	1100	≤ 100	87.4	62.4
FRA 20/1400 M20	945	1300	1400	≤ 150	136.6	97.6

For planning and design the complete European Technical Assessments ETA-17/1056 (FIS EM Plus), ETA-13/0651 (FIS SB) or ETA-20/0728 (FIS V Plus resp. FIS VS Plus LOW SPEED) have to be considered. For determination of the installation parameters (minimum concrete cover distances, etc.) as well as required transverse reinforcement see EN 1992-1-1 and general installation rules of the assessments.

- ¹⁾ The partial safety factors for resistance taken from the European standard EN 1992-1-1 as well as a partial safety factor for action of $\gamma_t = 1.4$ are considered.
- ²⁾ With FIS EM Plus, FIS SB or FIS V Plus and FIS V Plus LOW SPEED post-installed Rebar anchors are approved in dry or wet concrete with temperatures up to +50 °C (resp. short term up to +80 °C) and drill hole cleaning in accordance with ETA.
- ³⁾ The ETAs for FIS EM Plus, FIS SB, FIS V Plus and FIS V Plus LOW SPEED permit post-installed rebar connections in concrete C12/15 up to C50/60. The above mentioned basic value for anchorage length changes depending on the relevant concrete strength class.
- ⁴⁾ Basic value of the anchorage length in accordance with EN 1992-1-1, section 8.4.3 for concrete strength class C20/25 and good bond conditions.
- ⁵⁾ For utilisation of the full steel capacity.

General rules of construction

- The Rebar anchor FRA is permitted to transfer tension loads in direction of the axis of the rebar only.
- l_v and l_0 is according to approval.
- According to approval it has to be proved that sufficient transverse reinforcement is available.

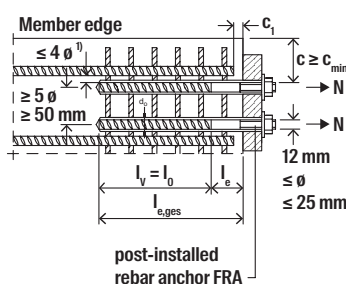

- c Concrete cover of the post-installed rebar anchor
- c_1 Concrete cover of the front side of the existing rebar
- l_e Concrete cover above the welding
- c_{min} Minimum concrete cover acc. to approval
- ϕ Diameter of the post-installed rebar anchor
- l_0 Lap length
- l_v Effective anchorage depth of the rebar anchor
- $l_{e,ges}$ Embedment depth of the rebar anchor
- d_0 Nominal drill diameter

Loads

Injection systems FIS EM Plus, FIS SB, FIS V Plus or FIS VS Plus LOW SPEED with reinforcing steel B500B⁵⁾ in accordance with rebar theory

Design resistances and permissible loads¹⁾ of single, post-installed rebars in cracked or non-cracked normal concrete of the strength class C20/25²⁾.

Reinforcing steel B500B fyk / fuk = 500 / 540 N/mm ²	Basic value for the anchorage length for FIS EM Plus	Basic value for the anchorage length for FIS SB	Basic value for the anchorage length for FIS V Plus FIS VS Plus LOW SPEED	Maximum anchorage depth	Maximum design resistance for axial tensile load	Maximum permissible tensile load
Type	l _{b,rqd} ⁴⁾ [mm]	l _{b,rqd} ⁴⁾ [mm]	l _{b,rqd} ⁴⁾ [mm]	l _{v,max} [mm]	N _{Rd,s} ³⁾ [kN]	N _{zul,s} ³⁾ [kN]
Ø 8 mm	378	378	378	1800 (3000) ⁸⁾	21.9	15.6
Ø 10 mm	473	473	473	1800 (3000) ⁸⁾	34.1	24.4
Ø 12 mm	567	567	567	1800 (3000) ⁸⁾	49.2	35.1
Ø 14 mm	662	662	662	1800 (3000) ⁸⁾	66.9	47.8
Ø 16 mm	756	756	756	1800 (3000) ⁸⁾	87.4	62.4
Ø 20 mm	945	945	945	1800 (3000) ⁸⁾	136.6	97.6
Ø 22 mm ⁷⁾	1040	–	–	2000	165.3	118.1
Ø 24 mm ⁷⁾	1134	–	–	2000	196.7	140.5
Ø 25 mm	1181	1181	1181	2000 (3000) ⁸⁾	213.4	152.4
Ø 26 mm ⁷⁾	1229	–	–	2000	230.8	164.9
Ø 28 mm	1323	1323	1323	2000 (3000) ⁸⁾	267.7	191.2
Ø 30 mm ⁷⁾	1418	–	–	2000	307.3	219.5
Ø 32 mm ⁹⁾	1512	1512	–	2000 (3000) ⁸⁾	349.7	249.8
Ø 34 mm ⁷⁾	1607	–	–	2000	394.7	282.0
Ø 36 mm ⁷⁾	1701	–	–	2000	442.6	316.1
Ø 40 mm ⁷⁾	1890	–	–	2000	546.4	390.3

For planning and design the complete European Technical Assessments ETA-17/1056 (FIS EM Plus), ETA-13/0651 (FIS SB) or resp. ETA-20/0728 (FIS V Plus und FIS VS Plus LOW SPEED) have to be considered. For determination of the installation parameters (minimum concrete cover distances, etc.) as well as required transverse reinforcement see EN 1992-1-1 and general installation rules of the assessments.

- ¹⁾ The partial safety factors for resistance taken from the European standard EN 1992-1-1 as well as a partial safety factor for action of $\gamma_L = 1.4$ are considered.
- ²⁾ The ETAs for FIS EM Plus, FIS SB, FIS V Plus and FIS VS Plus LOW SPEED permit post-installed rebar connections in concrete C12/15 up to C50/60. The above mentioned basic value for anchorage length changes depending on the relevant concrete strength class.
- ³⁾ For utilisation of the full steel capacity.
- ⁴⁾ Basic value of the anchorage length in accordance with EN 1992-1-1, section 8.4.3 for concrete strength class C20/25 and good bond conditions.
- ⁵⁾ All reinforcing steels with characteristic yield strength $f_{yk} = 400 - 600 \text{ N/mm}^2$ in accordance with EN 1992-1-1 Annex C, Table C.1 and C.2N. The above-mentioned basic value for the anchorage length as well as maximum steel resistance (see footnote 3) will change accordingly.
- ⁶⁾ With FIS EM Plus, FIS SB, FIS V Plus or FIS VS Plus LOW SPEED post-installed rebars are approved in dry or wet concrete with temperatures up to +50 °C (resp. short term up to +80 °C) and drill hole cleaning in accordance with ETA.
- ⁷⁾ Only FIS EM Plus.
- ⁸⁾ Values in brackets apply for FIS SB.
- ⁹⁾ Only FIS EM Plus or FIS SB.

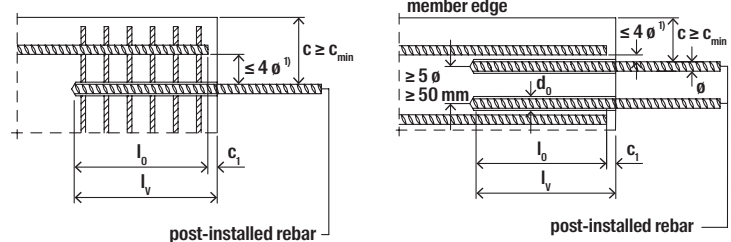

¹⁾ If the clear distance of the lapped bars is larger than $4 \times \phi$, EC2 must be applied.

Concrete-concrete shear connector FCC

The approved system for building renovation



Upgrade of bridges



Reinforcement of ceilings

3

Applications

- Bridge repairs
- Increasing load capacity of bridges
- Increasing loads of ceilings during conversion, for example
- Reinforcement of foundations, piers, columns and walls
- Renovation of car park ceilings following corrosion damage

Certificates



Advantages

- Due to its geometry and ease of installation, FCC is the rapid and economic alternative compared to the conventional installation method with bent iron.
- Dimensioning of the anchorage is possible thanks to the building approval. Thus, the system offers maximum security.
- Variable anchoring depths allow for ideal adaptation to the load to be applied, and

Building materials

Approved for:

- Concrete C20/25 to C50/60, cracked and non-cracked
- Fixing in old concrete B 25 to B 55

Versions

- Zinc-plated concrete steel bar B500B

ensure an optimised installation time and use of materials.

- Depending on site conditions, the FCC can be anchored, in compliance with the approval, with the injection mortars FIS SB or FIS EM Plus.
- In conjunction with FIS EM Plus, FCC is also approved for use in diamond-drilled drill holes.

Functioning

- The system consists of injection mortar (FIS SB or FIS EM Plus) and the concrete-concrete shear connector FCC.
- The mortar is injected bubble-free from the drill hole base.
- The mortar adheres the drill hole wall to the shear connector FCC.
- The shear connector is set manually, by lightly rotating it until it reaches the drill hole base.
- The tensile and shear forces arising in the joints between the old and new concrete are absorbed by the FCC-H and safely redirected.

Installation in concrete with FIS SB or FIS EM Plus and FCC-H

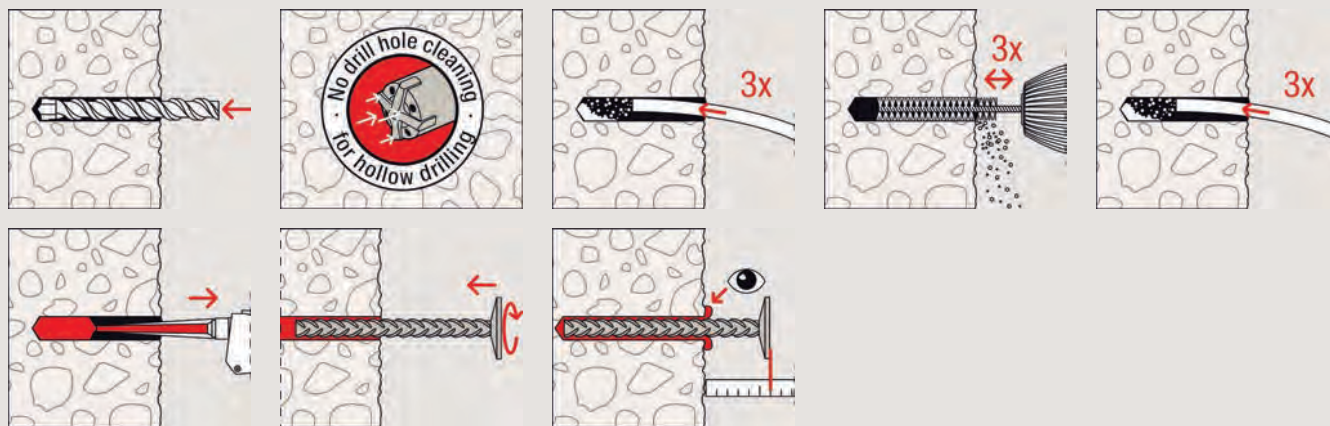

3

Technical data

Concrete-concrete shear connector FCC



FCC-H

Item	Item No.	Approval DIBt	Drill hole diameter d_0 [mm]	Rebar diameter [mm]	Anchor length [mm]	Min. / standard anchorage depth [mm]	Min. / standard fill quantity e.g. FIS SB [scale units]	Sales unit [pcs]
FCC-H 10 x 180	520081	●	12	10	180	60/120	2/4	100
FCC-H 12 x 230	520082 ¹⁾	●	14	12	230	70/155	3/7	50
FCC-H 14 x 290	520083 ¹⁾	●	18	14	290	75/195	6/14	50
FCC-H 16 x 360	520085 ¹⁾	●	20	16	360	80/240	7/20	25

¹⁾ Delivery time on request.

Remedial wall tie VBS 8

The professional façade repair for two-leaf cavity walls

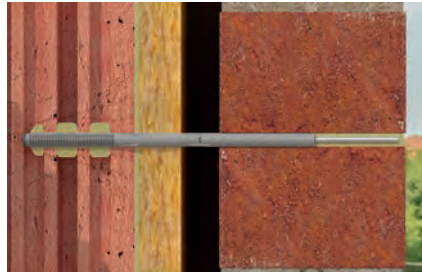

Detail: Repairing outer leaves

Applications

- Post-installation needling of two-skin cavity walls

Certificates



Advantages

- The expansion-force-free fixing prevents splitting and cracks. This means that VBS 8 can be used even in old and sensitive masonry.
- The drill bit diameter of just 8 mm means that a minimal amount of mortar is required for each fixing point. Thus VBS 8 is

particularly economical.

- The installation is approved anywhere along the entire bed joint, thus ensuring a high level of installation safety.
- The grey colour of the injection mortar is similar to the colour of the bed joint. This means that the fixing is almost invisible to the eye.

Building materials

- Facing masonry with and without an air layer

Versions

- Stainless steel

Functioning

- The remedial wall tie VBS 8 comprises a perforated plastic sleeve and a profiled stainless steel tie Ø 4 mm.
- VBS 8 is used together with the injection mortar FIS V Plus.
- The anchor is inserted in the bed joint of the outer leaf using push-through installation.

Installation in facing masonry with FIS V Plus and VBS 8

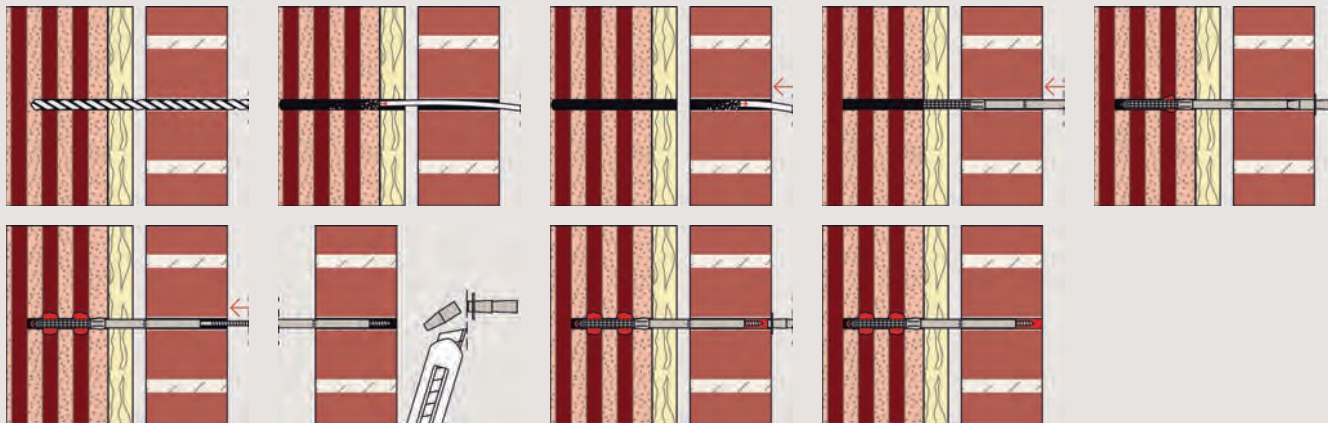

3

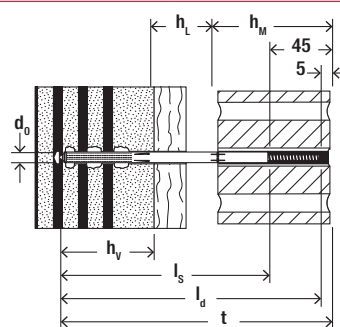

Technical data

Remedial wall tie VBS 8

VBS 8

Item	Stainless steel Item No.	Approval DIBt	Cavity or insulation h_L [mm]	Drill hole diameter d_0 [mm]	Outer leaf [mm]	Depth = embedment depth $h_0 = h_s$ [mm]	Fixing length l [mm]	Anchorage depth h_v [mm]	Fill quantity FIS V bearing wall [scale units]	Sales unit [pcs]
VBS 8/20	078763 ¹⁾²⁾	●	0 - 20	8	≥ 90	195	188	>60	4	100
VBS 8/50	078799 ¹⁾²⁾	●	20 - 50	8	≥ 90	225	218	>60	4	100
VBS 8/80	078800 ¹⁾²⁾	●	50 - 80	8	≥ 90	255	248	>60	4	100
VBS 8/120	078801 ¹⁾²⁾	●	80 - 120	8	≥ 90	295	288	>60	6	100
VBS 8/150	078802 ¹⁾²⁾	●	120 - 150	8	≥ 90	325	318	>60	6	100

1) Product consisting of perforated plastic sleeve, profiled wire R and injection nozzle.

2) For the closing of the curtain walling about 2-3 additional scale units of mortar are required.

Accessories

Accessories (Remedial wall tie VBS 8)



Compressed-air cleaning tool SDS-Plus Pointer, DIN 8039

Item	Item No.	Technical details	Sales unit [pcs]
VBS 8 cleaning set	090241	content: cleaning brush and extension tube for blow-out pump	1
Compressed-air cleaning tool	093286	for professional cleaning of the drill hole	1
SDS-Plus Pointer 8,0 / 460 mm	074330	Hammer drill with self-centring drill bit and relief-ground drill grooving	1

Weather facing reconstruction system FWS II

The economical solution for the repair of triple-skin outer wall panels



Repairing weather shells



Detail: Repairing weather shells

3

Applications

- For post-installation securing of triple-skin outer wall panels
- Strengthening outer wall panels for additional exterior insulation

Certificates



Advantages

- The FWS II achieves a high shear load-bearing capacity due to its large anchor diameter. This reduces the number of reconstruction anchors needed for each plate to a minimum, thus saving costs.
- The drill hole can be drilled in one step using standard diamond drill bits. This

ensures quick progress is made.

- Installation is already approved from a sub-base thickness ≥ 80 mm.
- Approval with a new measuring strategy allows a safer and economically static calculation while making it possible to document loads from temperature changes.

Building materials

- Triple-skin outer wall panels made of concrete $\geq C12/15$

Versions

- Stainless steel

Functioning

- The FWS II weather facing reconstruction anchors can be bedded in mortar into the load-bearing skin and weather shell with the FIS V Plus, FIS VW Plus or FIS VS Plus / FIS V, FIS VW or FIS VS injection mortar.
- The red plastic coating protects the insulation from being penetrated with mortar.
- You can see the correct anchor filling with the weather shell through the inspection openings on the head of the anchor.

Installation in triple skin outer wall panels with FIS V Plus and FWS II-A

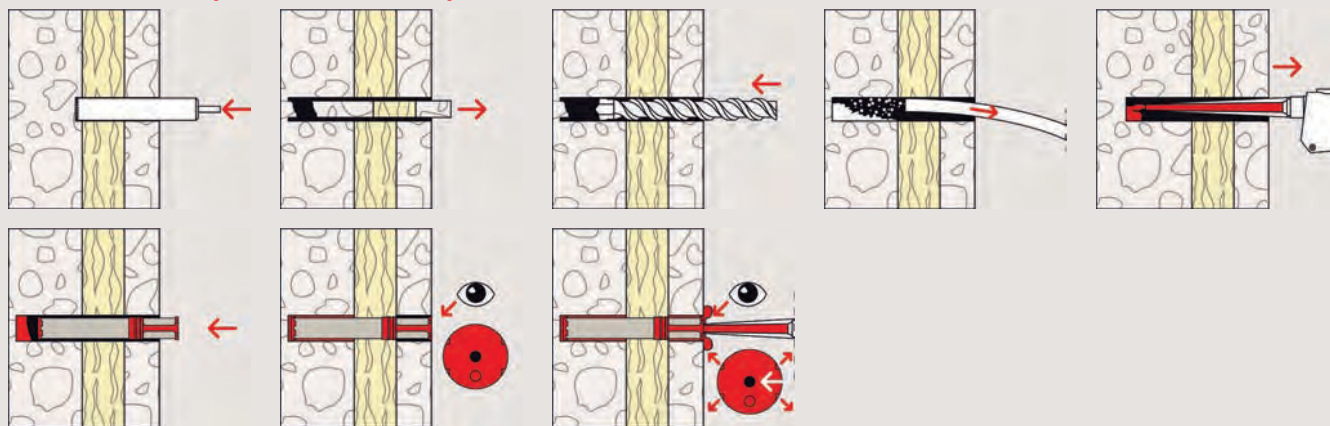

3

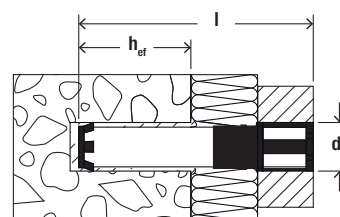

Technical data

Weather facing reconstruction system FWS II



FWS II - A

Item	Item No.	Approval DIBt	Total length [mm]	Nom. drill diameter d_0 [mm]	Effect. anchorage depth in the load-bearing skin h_{ef} [mm]	Anchors per cartridge FIS V / FIS VS / FIS VW 360 ml	Sales unit [pcs]
FWS II - A 180	532883	●	180	40 - 41	70	5	5
FWS II - A 205	532884	●	205	40 - 41	70	5	5
FWS II - A 230	532885	●	230	40 - 41	70	5	5

Technical data

Injection mortar FIS V



FIS V 360 S



FIS V Plus 360 S

Item	Item No.	Approval DIBt ETA	Languages on the cartridge	Scale unit	Contents	Sales unit [pcs]
FIS V 360 S	559429	● ●	DE, FR, NL	180	1 cartridge 360 ml, 2 x FIS MR Plus	6
FIS V Plus 360 S (IN)	558744	● ●	EN	180	1 cartridge 360 ml, 2 x FIS MR Plus	6

For further injection mortars see page FIS V Plus / FIS V

Loads

Weather facing reconstruction system FWS II

Permissible shear loads^{1) 2)} for a single anchor in a load-bearing skin made of concrete \geq C12/15.
For the design the complete approval Z-21.8-2029 has to be considered.

Type	Effective anchorage depth in the load-bearing skin	Thickness of load-bearing layer	Thickness of - thermal insulation ³⁾	Thickness of- outer leaf	Permissible bending moment	Cracked and non-cracked concrete	
	$h_{ef} \geq$ [mm]	$h_T \geq$ [mm]	$h_D \leq$ [mm]	$h_w \geq$ [mm]		Permissible shear load ⁴⁾	Mindestrand-abstand ⁵⁾
					M_{zul} [Nm]	V_{zul} [kN]	$c_{min} (c_w, c_T)$ [mm]
FWS II - A 180	70	80	70	40	1310	11.5	150
FWS II - A 205	70	80	95	40	1310	9.5	150
FWS II - A 230	70	80	120	40	1310	8.1	150

¹⁾ Required safety factors are considered. The given loads are valid under the pre-condition that an additional thermal insulation will be applied on the weather facing.

²⁾ The given loads are valid for fixations in dry and humid concrete for temperatures in the substrate up to +50 °C (resp. short term up to 80 °C) and drillhole cleaning according to approval.

³⁾ For bigger insulation thicknesses special lengths are possible.

⁴⁾ The determination of the permissible shear load for special lengths is done according Annex 3 and 4 of the approval.

⁵⁾ For exact arrangement of the bolts as well as for eventually needed additional proofs see approval.

Can system FCS

The epoxy resin for repair work

3

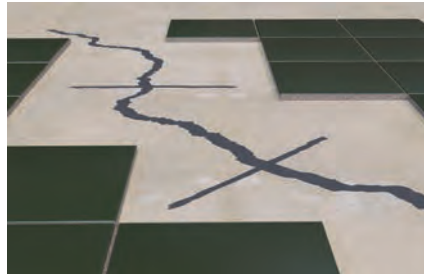

Filling cracks



Reconstructing corners and edges

Applications

- Filling holes and cracks in concrete and similar surfaces
- Reconstructing chipped corners and edges

Advantages

- The FCS based on epoxy resin has a high bond strength and a low shrinkage value. This guarantees a high performance and opens up a wide range of applications.
- The two product variants, FCS Liquid

(low viscosity = liquid) and FCS (high viscosity = paste-like), allow for use both in horizontal situations and on walls and ceilings. Therefore, there is always the right product for every occasion.

Building materials

- Suitable for:
- Concrete

Functioning

- The resin and hardener are stored in two separate containers.
- The hardener is added to the resin and mixed thoroughly until the material is the same colour throughout.
- Note: The quality of the mixing of components and the proper filling of the holes (without air pockets) has an effect on the load-bearing capacity of the system!
- FCS Liquid can be poured into holes or cracks, or applied using a brush.
- FCS can be applied with a palette knife.
- Once mixed, the material can be used until the maximum open time is reached.

Installation FCS

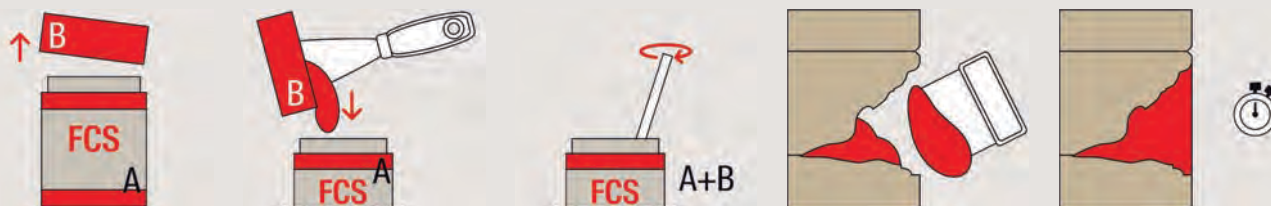

Installation FCS Liquid



3

Technical data

Can system FCS



FCS

FCS liquid

Item	Item No.	Languages on the can	Sales unit [pcs]
FCS - fischer Can System	043676 ¹⁾	EN, ES, PT	12
FCS Liquid - fischer Can System	043917 ¹⁾	EN, ES, PT	12

¹⁾ Dangerous goods - no express shipping possible.

Curing times

FCS Temperature [°C]	Processing time [min.]	Curing time [hrs.]
+5	70	60
+10	60	30
+20	45	24
-30	30	20
+40	15	16

The gelling time starts when the components get in contact. Stir the components thoroughly until the colour of the mortar is evenly. This is essential to achieve the full performance of the mortar.

Fill & Fix injection fixing

Liquid plugs and repair compounds for serious cases

3



Repairing damaged drill holes



Repairing damaged hinges

Applications

- Repairing cracked or over-sized drill holes
- Repairing broken furniture hinges etc.
- Fixing lightweight objects in difficult or damaged building materials (old buildings)
- Fixing lightweight objects in internal and UV-protected external areas

Advantages

- The Fill & Fix injection fixing works whatever the drill hole size and building material. As a result, a number of applications can be completed with just one product.
- Wood screws can be screwed directly into the hardened injection fixing. This allows for a fast and simple installation.
- Due to the special formulation, the screw

can be screwed into the injection fixing and removed. Thus, components can be reattached to the same point.

- Fill & Fix can be sanded and painted, and is suitable for filling drill holes that are no longer needed prior to painting.

Building materials

- Concrete
- Vertically perforated brick
- Hollow blocks made from lightweight concrete
- Cavity floor slabs made from bricks and concrete
- Wooden materials
- Perforated sand-lime brick
- Solid sand-lime brick
- Natural stone with dense structure
- Panel building materials
- Aerated concrete
- Solid panel made from gypsum
- Solid brick made from lightweight concrete
- Solid brick

Functioning

- Fill & Fix is a 2-component, solvent-free injection compound based on polyurethane. It is applied into the drill hole, where it foams lightly and sets quickly.
- The increase in volume during the setting process guarantees a secure hold, even in dilapidated or difficult building materials.
- After approx. 2 minutes, screws, hooks, eye screws etc. with a diameter of up to 6 mm that are normally used in wood can be screwed into and removed from the set material without pre-drilling.
- Use the perforated sleeves (included) for hollow and board building materials.

Installation in solid building materials

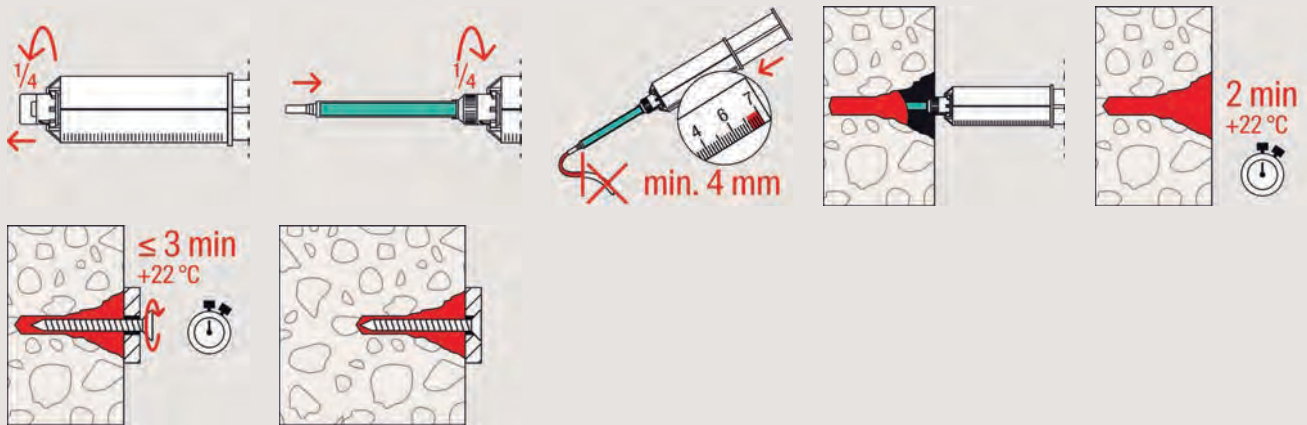

Installation in hollow and panel building material

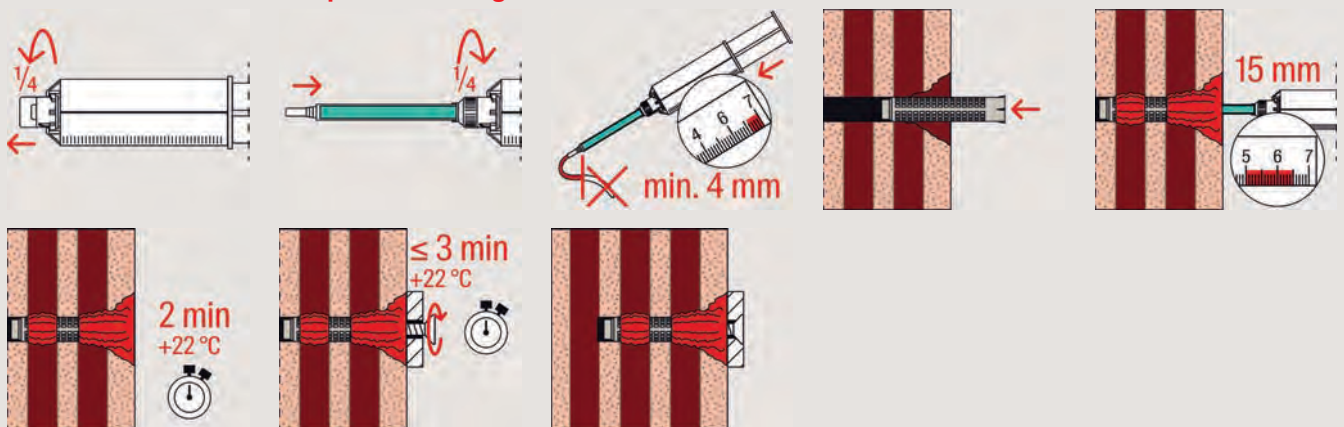

Technical data

fill & fix injection fixing



Fill & Fix

Item	Item No.	Contents	Languages on the cartridge	Sales unit [pcs]
Fill & Fix K (D)	051097 ¹⁾	1 cartridge 25 ml, 2 static mixer, 4 anchor sleeves, 2 extension tubes	DE	4
Fill & Fix K (D/F)	503227	1 cartridge 25 ml, 2 static mixer, 4 anchor sleeves, 2 extension tubes	D, F	8
Fill & Fix K (F)	513500	1 cartridge 25 ml, 2 static mixer, 4 anchor sleeves, 2 extension tubes	F	8
Fill & Fix K (I)	051098	1 cartridge 25 ml, 2 static mixer, 4 anchor sleeves, 2 extension tubes	I	8
Fill & Fix K (S/DK)	505083	1 cartridge 25 ml, 2 static mixer, 4 anchor sleeves, 2 extension tubes	S, DK	8
Fill & Fix K (GR)	505084	1 cartridge 25 ml, 2 static mixer, 4 anchor sleeves, 2 extension tubes	GR	8
Fill & Fix Static mixer	502735	6 static mixer	—	1

1) Dangerous goods - no express shipping possible.

Loads

Fill & Fix					
Recommended loads ^{1) 2)} for a single anchor. The given loads are valid for chipboard screws with the specified diameters.					
Type			Fill & Fix		
Diameter of chipboard screw	Ø	[mm]	4.0	5.0	6.0
Nominal drill diameter	d ₀	[mm]	10	10	10
Anchorage depth	h _{ef} ≥	[mm]	45	45	45
Drill hole depth	h ₁ ≥	[mm]	50	50	50
Anchorage in solid substrates					
Recommended load in concrete	≥ C12/15	[kN]	0.50	0.60	0.70
Recommended load in sand-lime bricks	≥ KS 20, ≥ NF	[kN]	0.50	0.60	0.70
Anchorage in perforated bricks/hollow blocks using the perforated sleeve					
Recommended load in vertically perforated bricks	≥ HLz 12, ρ ≥ 0.9 kg/dm ³ , ≥ 16DF	[kN]	0.20	0.25	0.30
Recommended load in perforated sand-lime bricks	≥ KSL 12, ρ ≥ 1.4 kg/dm ³ , ≥ 5DF	[kN]	0.20	0.25	0.30
Recommended load in lightweight concrete hollow blocks	≥ Hbl 4, 2K, ≥ 8DF	[kN]	0.20	0.25	0.30
Anchorage in aerated concrete					
Recommended load in aerated concrete	≥ PB2, PP2	[kN]	0.10	0.15	0.20
Anchorage in board materials using the perforated sleeve					
Recommended load in gypsum plasterboard	12.5 mm	[kN]	0.12	0.12	0.12
Recommended load in gypsum plasterboard	25 mm (= 2 × 12.5 mm)	[kN]	0.20	0.20	0.20
Recommended load in gypsum fibreboard	12.5 mm	[kN]	0.21	0.21	0.21

¹⁾ Required safety factors are considered.

²⁾ Valid for tensile load, shear load and oblique load under any angle.

									
	FIS ... 150 T	FIS ... 300 T	FIS ... 345 S	FIS ... 360 S	FIS ... 380/410 C	FIS ... 390 S	FIS ... 585 S	FIS ... 1500 S	

Mortar Cartridges

	•	•	•	•	—	•	—	—	190
FIS DMS (51118)									
	•	•	•	•	—	•	—	—	190
FIS AM (58000)									
	•	•	—	—	—	—	—	—	190
KP M1 (53115)									
	•	•	—	—	—	—	—	—	190
KP M2 (53117)									
	—	—	—	—	•	—	—	—	190
FIS AC (96497)									
	—	—	—	—	—	—	•	—	190
FIS DMS-L (510992)									
	—	•	•	•	—	•	—	—	191
FIS DCD S (543629)									
	•	•	•	•	—	•	—	—	191
FIS AP (58027)									
	—	—	—	—	—	—	•	—	191
FIS DP-S L (511125)									
	—	—	—	—	—	—	—	•	191
FIS DP-S XL (512401)									

Dispenser

FIS DMS (511118)



3

Applications

- Shuttle cartridges with 360 and 390 ml content
- Cartridges with 150 ml content
- Multibond cartridges with 300 ml content
- Standard silicone cartridges

Advantages

- The 3-fold push rod distributes the extrusion forces equal over the cartridge and prevents the cartridge from tearing up.
- The robust glass fiber reinforced plastic housing increases the breaking strength of the dispenser and offers a long service life.
- The ergonomic design of the FIS DMS ensures a good balance and allows fatigue-free working.

FIS AM (58000)



Applications

- Shuttle cartridges with 360 and 390 ml content
- Cartridges with 150 ml content
- Multibond cartridges with 300 ml content
- Standard silicone cartridges

Advantages

- The robust design can withstand the high requirements of the job site and thus offers a long life.
- The infinitely variable feed allows the exact dosing and thus ensures easy handling.

KP M1 (53115)



Applications

- Cartridges with 150 ml content
- Multibond cartridges with 300 ml content
- Standard silicone cartridges

Advantages

- The handy, robust solid metal construction for standard cartridges up to 310 ml bears up against requirements on the construction site and, as such, is also suitable for professional use.
- The continuous in-feed allows for a precise dosage, making it easy to use.
- The slim shape of the device allows for an exact application, even in difficult to reach spots, thus offering a high level of flexibility

Dispenser

KP M2 (53117)



Applications

- Cartridges with 150 ml content
- Multibond cartridges with 300 ml content
- Standard silicone cartridges

Advantages

- The 18:1 transmission ratio enables the fast, low-energy application of even highly viscous materials, thus ensuring stress-free work.
- The robust design with the special, hardened drive block meets the tough requirements of a construction site and thus offers a long lifespan.
- The freely accessible cartridge makes it possible to perfectly align the extrusion nozzle, guaranteeing application-oriented work.

FIS AC (96497)



Applications

- Coaxial cartridges with 380 and 410 ml content

Advantages

- The robust design can withstand the high requirements of the job site and thus offers a long life.
- The infinitely variable feed allows the exact dosing and thus ensures easy handling.

FIS DMS-L (510992)



Applications

- Cartridges with 585 ml content

Advantages

- The patented parallel lever of the FIS DM S-L allows a large and even force transmission and ensures fatigue-free working.
- The dropout protection on the cartridge holder provides a secure hold of the cartridge in the dispenser.

Dispenser

FIS DCD S (543629)



Applications

- Shuttle cartridges with 360 and 390 ml content
- Multibond cartridges with 300 ml content

Advantages

- The FIS DCD S has a dosing function which is controlled by a setting wheel. This allows for optimal adaptation to the processing conditions and ensures fast work progress.
- The robust battery dispenser is very light, fits comfortably in the hand and allows fatigue-free working.
- Additional battery pack for FIS DCD S available (#543946)

FIS AP (58027)



Applications

- Shuttle cartridges with 360 and 390 ml content
- Cartridges with 150 ml content
- Multibond cartridges with 300 ml content
- Standard silicone cartridges

Advantages

- The fast venting minimises cartridge after-run, which facilitates clean work at the site.
- The reducing valve in the handle enables the optimum adjustment of the volume flow in line with the processing conditions.
- Due to the ergonomically formed handle, the dispensers fit nicely in your hand and make work less tiring.

FIS DP-S L (511125)



Applications

- Cartridges with 585 ml content

Advantages

- The fast venting minimises cartridge after-run, which facilitates clean work at the site.
- The reducing valve in the handle enables the optimum adjustment of the volume flow in line with the processing conditions.
- Due to the ergonomically formed handle, the dispensers fit nicely in your hand and make work less tiring.

Dispenser

FIS DP-S L (511125)



Applications

- Cartridges with 1500 ml content

Advantages

- The fast venting minimises cartridge after-run, which facilitates clean work at the site.
- The reducing valve in the handle enables the optimum adjustment of the volume flow in line with the processing conditions.
- Due to the ergonomically formed handle, the dispensers fit nicely in your hand.
- In addition the dispenser has a carrying strap around which make work less tiring.

Accessories

Accessories for drill hole cleaning

Cleaning brushes



Item	Item No.	Length [mm]	Length [mm]	Brush diameter [mm]	For drill diameter [mm]	Sales unit [pcs]
BS ø 8	078177	120	50	9	8	1
BS ø 10	078178	120	50	11	10	1
BS ø 12	078179	150	80	13	12	1
BS ø 14	078180	250	80	16	14	1
BS ø 16/18	078181	250	80	20	16/18	1
BS ø 20/22	052277	180	80	25	20/22	1
BS ø 24	078182	300	100	26	24	1
BS ø 25	097806	300	100	27	25	1
BS ø 28	078183	350	100	30	28	1
BS ø 30/32/35	078184	400	100	40	30/32/35	1
FIS brush extension	508791	410	—	—	—	1
Compressed air nozzle D16-D19	511957	—	—	—	—	2
Compressed air nozzle D20-D25	511958	—	—	—	—	2

Accessories

Drill hole cleaning (air)



Item	Item No.	Contents	Total length [mm]	Sales unit [pcs]
Compressed-air cleaning tool	093286	—	—	1
Blow-out pump AB G	089300	—	370	1
Centring wedge	093076	10 wedges for overhead installation, from M16	—	1

Accessories

Adapters and setting tools



Item	Item No.	Match	Sales unit [pcs]
RA-SDS	062420	Adapter suitable fits set screw	1
SK SW 8 1/2	001536	Adapter suitable fits threaded rods M8 - M22	1
SDS plus 1/2	001537	Adapter suitable fits threaded rods M8 - M16	1
SDS max 1/2	001538	Adapter suitable fits threaded rods M16 - M20	1
SDS max 3/4	001539	Adapter suitable fits threaded rods M20 - M30	1

Technical data

Conical drill bit



PBB

























PBZ

Item	Item No.	Approval	Match	Contents	Sales unit [pcs]
		ETA			
Cone drill PBB	090634	●	M8 - M12; FIS E	1x cone drill PBB	1
Centring sleeve PBZ	090671	●	M8 - M12; FIS E	10x centring sleeve PBZ, 5x injection adapter	10



4

High performance steel anchors

Bolt anchor FAZ II	198		Ceiling nail FDN II	263	
High performance anchor FH II	205		Ceiling nail FDZ	266	
High performance anchor FH II-I	211		Bolt anchor FBN II	269	
ZYKON undercut anchor FZA	214		Bolt anchor FXA	275	
ZYKON hammerset anchor FZEA II	221		Bolt anchor FWA	277	
Concrete screw UltraCut FBS II 8-14	224		Heavy-duty anchor TA M	281	
Concrete screw UltraCut FBS II 6	234		Heavy-duty anchor TA M-T	285	
Concrete screw FBS N	239		Sleeve anchor FSA	288	
Hammerset anchor EA II	242		Fixing set for diamond drills FDBB	291	
Hammerset anchor EA Plus	247		Wall screw MR	293	
Hammerset anchor EA-N	250		Hollow-ceiling anchor FHY	295	
Nail anchor FNA II	254		Aircrete anchor FPX-I	298	
Nail anchor FNA II RB	259				

Bolt anchor FAZ II

For highest demands. Powerful and flexible.

4



Balcony railings



Steel girders

Applications

- Steel constructions
- Guard rails
- Consoles
- Ladders
- Cable trays
- Machines
- Staircases
- Gates
- Façades
- Timber constructions

Advantages

- According to the new assessment (ETA) the tensile load capacities are decisively increased. This requires less anchors.
- The variable anchorage depths for the sizes M8 to M16 allow for the first time a millimeter-accurate adjustment to the loads.
- The design with cap nut offers a visually attractive anchoring and protects against

- injuries due to the round head shape.
- The first bolt anchor M6 with ETA Assessment for Option 1, for secure and approved anchorage.
- The international approvals guarantees maximum safety and the best performance.
- Approved for diamond-drilled holes.

Certificates



ETA-05/0069, for cracked concrete



from M10



ICC ESR-2948



Fire resistance classification R120



INOX STAINLESS STEEL



ZTV



Building materials

Approved for:

- Concrete C20/25 to C50/60, cracked and non-cracked

Also suitable for:

- Concrete C12/15
- Concrete C80/95
- Natural stone with dense structure

Versions

- Zinc-plated steel
- Stainless steel R
- Highly corrosion-resistant steel HCR

Functioning

- The FAZ II is suitable for pre-positioned and push-through installation and is also ideal for stand-off installation thanks to the long thread.
- When applying the torque, the cone bolt is pulled into the expansion sleeve and expand it against the drill hole wall.
- The anchor is set in line with the approval once the preset installation torque is achieved.
- In the case of series installation, we recommend using the FABS anchor bolt setting tool or our setting tool FA-ST.

Push-through installation with hexagon nut

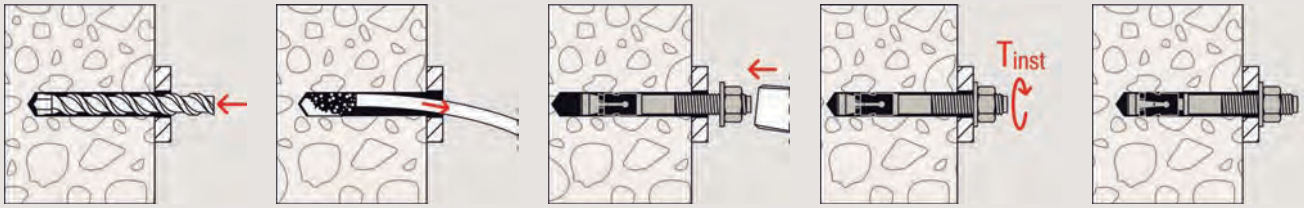

Push-through installation of the cup nut version with setting gauge

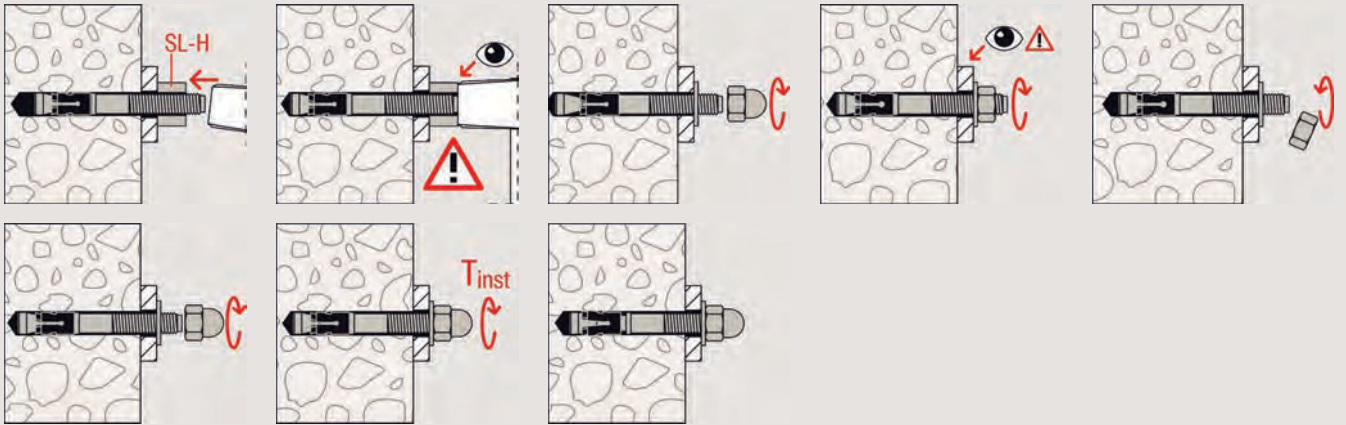

4

Installation with setting tool

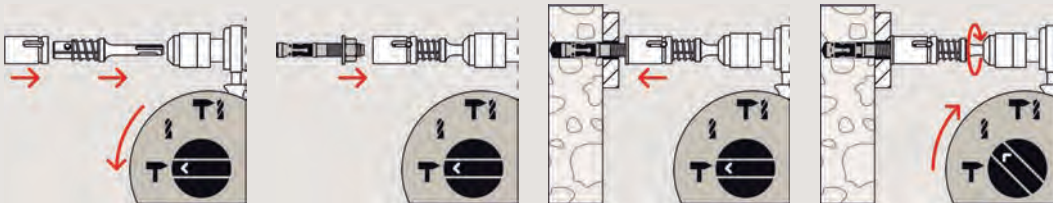

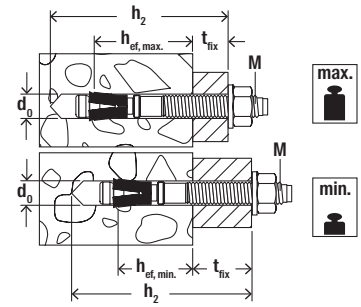

Technical data

Bolt anchor FAZ II

4



FAZ II

Item	Zinc-plated steel	Stainless steel	Highly corrosion resistant steel	Approval		Seismic-Approval	Drill hole diameter	Min. drill hole depth for through fixings	Max. usable length hef,max./ hef,min.	Anchor length	Thread	Width across nut	Sales unit
	Item No.	Item No.	Item No.	ETA	ICC		d_0 [mm]	h_2 [mm]	t_{fix} [mm]	l [mm]	$\emptyset \times$ length [mm]	SW [mm]	[pcs]
	gvz	R	HCR										
FAZ II 6/10	542621	542623	—	●	—	—	6	60	10/-	65	M 6 x 25	10	50
FAZ II 6/20	542622	542624	—	●	—	—	6	70	20/-	75	M 6 x 35	10	50
FAZ II 8/10	094871 ¹⁾	501396 ¹⁾	—	●	●	C1	8	65	10/20	75	M 8 x 38	13	50
FAZ II 8/10	—	—	501428 ¹⁾	●	●	C1	8	65	10/20	75	M 8 x 38	13	10
FAZ II 8/30	094877 ¹⁾	501399 ¹⁾	—	●	●	C1	8	85	30/40	95	M 8 x 58	13	50
FAZ II 8/30	—	—	501429 ¹⁾	●	●	C1	8	85	30/40	95	M 8 x 58	13	10
FAZ II 8/50	094878 ¹⁾	501401	—	●	●	C1	8	105	50/60	115	M 8 x 78	13	50
FAZ II 8/100	094879 ¹⁾	—	—	●	●	C1	8	155	100/110	165	M 8 x 128	13	25
FAZ II 8/160	503251 ¹⁾	—	—	●	●	C1	8	215	160/170	225	M 8 x 100	13	20
FAZ II 10/10	094981	501403	—	●	●	C1 / C2	10	85	10/30	95	M 10 x 53	17	50
FAZ II 10/10	—	—	501430	●	●	C1	10	85	10/30	95	M 10 x 53	17	10
FAZ II 10/20	094982	—	—	●	●	C1 / C2	10	95	20/40	105	M 10 x 63	17	25
FAZ II 10/20	—	501406	—	●	●	C1 / C2	10	95	20/40	105	M 10 x 63	17	50
FAZ II 10/30	094983	—	—	●	●	C1 / C2	10	105	30/50	115	M 10 x 73	17	25
FAZ II 10/30	—	501407	—	●	●	C1 / C2	10	105	30/50	115	M 10 x 73	17	50
FAZ II 10/30	—	—	503185	●	●	C1	10	105	30/50	115	M 10 x 73	17	10
FAZ II 10/50	094984	501409	—	●	●	C1 / C2	10	125	50/70	135	M 10 x 93	17	20
FAZ II 10/70	—	501410	—	●	●	C1 / C2	10	145	70/90	155	M 10 x 113	17	20
FAZ II 10/80	094985	—	—	●	●	C1 / C2	10	155	80/100	165	M 10 x 123	17	20
FAZ II 10/100	—	501411	—	●	●	C1 / C2	10	175	100/120	185	M 10 x 100	17	20
FAZ II 10/100	094986	—	—	●	●	C1 / C2	10	175	100/120	185	M 10 x 143	17	20
FAZ II 10/160	—	501412	—	●	●	—	10	235	160/180	245	M 10 x 100	17	20
FAZ II 10/160	503252	—	—	●	●	—	10	235	160/180	245	M 10 x 193	17	20
FAZ II 12/10	095419	501413	—	●	●	C1 / C2	12	100	10/30	110	M 12 x 61	19	20
FAZ II 12/10	—	—	503186	●	●	C1	12	100	10/30	110	M 12 x 61	19	10
FAZ II 12/20	095420	501415	—	●	●	C1 / C2	12	110	20/40	120	M 12 x 71	19	20
FAZ II 12/30	095421	501416	—	●	●	C1 / C2	12	120	30/50	130	M 12 x 81	19	20
FAZ II 12/30	—	—	501431	●	●	C1	12	120	30/50	130	M 12 x 81	19	10
FAZ II 12/50	095446	501419	—	●	●	C1 / C2	12	140	50/70	150	M 12 x 101	19	20
FAZ II 12/60	—	501420	—	●	●	C1 / C2	12	150	60/80	160	M 12 x 111	19	20
FAZ II 12/80	095454	—	—	●	●	C1 / C2	12	170	80/100	180	M 12 x 131	19	20
FAZ II 12/100	095470	501421	—	●	●	C1 / C2	12	190	100/120	200	M 12 x 151	19	20
FAZ II 12/160	503253	—	—	●	●	—	12	250	160/180	260	M 12 x 186	19	10
FAZ II 12/160	—	503180	—	●	●	—	12	250	160/180	260	M 12 x 100	19	20
FAZ II 12/200	095605	—	—	●	●	—	12	290	200/220	300	M 12 x 186	19	10
FAZ II 16/5	522124	—	—	●	●	C1 / C2	16	115	5/25	128	M 16 x 64	24	10
FAZ II 16/5	—	522125	—	●	●	C1 / C2	16	115	5/25	128	M 16 x 64	24	20
FAZ II 16/25	—	501423	—	●	●	C1 / C2	16	135	25/45	148	M 16 x 84	24	20

¹⁾ With minimum embedment depth only for statically indeterminate systems

Approval Seismic C1/C2 only with maximum embedment depth

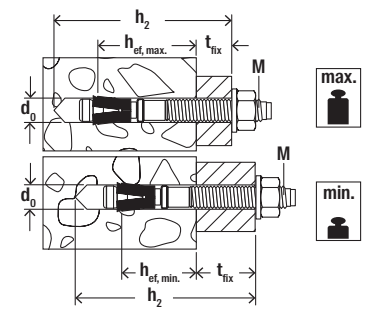

Technical data

Bolt anchor FAZ II



FAZ II

Item	Zinc-plated steel	Stainless steel	Highly corrosion resistant steel	Approval		Seismic-Approval	Drill hole diameter d_0 [mm]	Min. drill hole depth for through fixings h_2 [mm]	Max. usable length hef,max./hef,min. t_{fix} [mm]	Anchor length l [mm]	Thread \emptyset x length [mm]	Width across nut SW [mm]	Sales unit [pcs]
	Item No. gvz	Item No. R	Item No. HCR	ETA	ICC								
FAZ II 16/25	—	—	501432	●	●	C1	16	135	25/45	148	M 16 x 84	24	10
FAZ II 16/25	095836	—	—	●	●	C1 / C2	16	135	25/45	148	M 16 x 84	24	10
FAZ II 16/50	095864	—	—	●	●	C1 / C2	16	160	50/70	173	M 16 x 109	24	10
FAZ II 16/50	—	—	503187	●	●	C1	16	160	50/70	173	M 16 x 109	24	10
FAZ II 16/50	—	501424	—	●	●	C1 / C2	16	160	50/70	173	M 16 x 109	24	20
FAZ II 16/100	095865	501425	—	●	●	C1 / C2	16	210	100/120	223	M 16 x 159	24	10
FAZ II 16/160	503254	—	—	●	●	C1 / C2	16	270	160/180	283	M 16 x 189	24	10
FAZ II 16/200	095967	—	—	●	●	—	16	310	200/220	323	M 16 x 189	24	10
FAZ II 16/250	095968	—	—	●	●	—	16	360	250/270	373	M 16 x 100	24	10
FAZ II 16/300	096188	—	—	●	●	—	16	410	300/320	423	M 16 x 100	24	10
FAZ II 20/30	046632	—	—	●	●	C1 / C2	20	155	30/-	172	M 20 x 54	30	5
FAZ II 20/30	—	501426	—	●	●	C1 / C2	20	155	30/-	172	M 20 x 54	30	4
FAZ II 20/60	046633	—	—	●	●	C1 / C2	20	185	60/-	202	M 20 x 84	30	5
FAZ II 20/60	—	503183	—	●	●	C1 / C2	20	185	60/-	202	M 20 x 84	30	4
FAZ II 20/160	503255	—	—	●	●	C1 / C2	20	285	160/-	302	M 20 x 100	30	5
FAZ II 24/30	046635	—	—	●	●	C1	24	185	30/-	205	M 24 x 58	36	5
FAZ II 24/30	—	501427	—	●	●	C1	24	185	30/-	205	M 24 x 58	36	4
FAZ II 24/60	046636	—	—	●	●	C1	24	215	60/-	235	M 24 x 88	36	5
FAZ II 24/60	—	503184	—	●	●	C1	24	215	60/-	235	M 24 x 88	36	4

1) With minimum embedment depth only for statically indeterminate systems

Approval Seismic C1/C2 only with maximum embedment depth

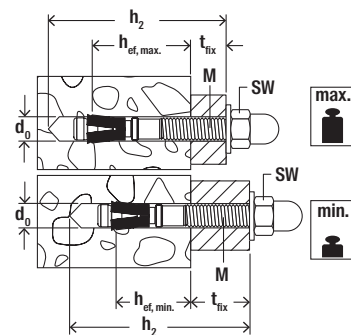

Technical data

4

Bolt anchor FAZ II H



Item	Zinc-plated steel	Stainless steel	Approval	Seismic-Approval	Drill hole diameter	Min. drill hole depth for through fixings	Anchor length	Max. usable length hef,max./ hef,min.	Thread	Width across nut	Sales unit
	Item No.	Item No.			d_0 [mm]	h_2 [mm]		t_{fix} [mm]		\emptyset x length [mm]	
Item	gvz	R	ETA								
FAZ II 10/10 H	543392	543396	●	C1 / C2	10	87	95	10/30	M 10 x 53	17	20
FAZ II 10/20 H	543393	543397	●	C1 / C2	10	97	105	20/40	M 10 x 63	17	20
FAZ II 12/10 H	543394	543398	●	C1 / C2	12	99	109	10/30	M 12 x 61	19	20
FAZ II 12/20 H	543395	543399	●	C1 / C2	12	109	119	20/40	M 12 x 71	19	20
Cap nut FAZ II M10	543977 ¹⁾	543979 ¹⁾	●	—	—	—	—	—	M 10	17	20
Cap nut FAZ II M12	543978 ¹⁾	543980 ¹⁾	●	—	—	—	—	—	M 12	19	20

1) Can be combined with all bolt anchors FAZ II M10 and M12 in accordance with approval.

Approval Seismic C1/C2 only with maximum embedment depth

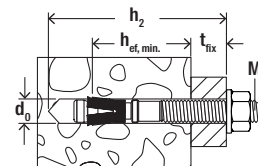

Technical data

Bolt anchor FAZ II K



Item	Zinc-plated steel	Stainless steel	Approval	Drill hole diameter	Min. drill hole depth for through fixings	Anchor length	Usable length (hef min.)	Thread	Washer (outer diameter x thickness)	Sales unit
	Item No.	Item No.		d_0 [mm]	h_2 [mm]		t_{fix} [mm]		\emptyset x length [mm]	
Item	gvz	R	ETA							
FAZ II 8/5 K	538989	538990	●	8	45	60	5	M 8 x 23	16 x 1,6	50
FAZ II 10/10 K	522108	522116	●	10	65	75	10	M 10 x 33	20 x 2	50
FAZ II 10/20 K	522110	—	●	10	75	85	20	M 10 x 43	20 x 2	25
FAZ II 10/20 K	—	522117	●	10	75	85	20	M 10 x 43	20 x 2	50
FAZ II 12/10 K	522118	522122	●	12	80	90	10	M 12 x 41	24 x 2,5	20
FAZ II 12/20 K	522119	522123	●	12	90	100	20	M 12 x 51	24 x 2,5	20
FAZ II 10/10 K GS	522115	—	●	10	65	75	10	M 10 x 33	25 x 3	50
FAZ II 12/10 K GS	522121	—	●	12	80	90	10	M 12 x 41	30 x 3	20

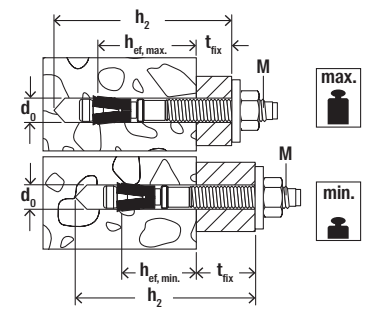

Technical data

Bolt anchor FAZ II GS and HBS



FAZ II GS with large washer

FAZ II HBS washer compliant to wood construction standard DIN 1052

Item	Steel, zinc-plated, with large washer	Stainless steel, with large washer	Approval	Seismic-Approval	Drill hole diameter	Min. drill hole depth for through fixings	Anchor length	Max. usable length hef,max./ hef,min.	Thread	Width across nut	Washer (outer diameter x thickness)	Sales unit
	Item No.	Item No.			d_0 [mm]	h_2 [mm]	l [mm]	t_{fix} [mm]	\emptyset x length [mm]	SW [mm]	[mm]	[mm]
	gvz	R	ETA									
FAZ II 8/10 GS	094872	501398	●	C1	8	65	75	10/20	M 8 x 38	13	22 x 2,5	50
FAZ II 8/30 GS	096189	501400	●	C1	8	85	95	30/40	M 8 x 58	13	22 x 2,5	50
FAZ II 10/10 GS	096291	501405	●	C1 / C2	10	85	95	10/30	M 10 x 53	17	25 x 3	50
FAZ II 10/30 GS	096297	—	●	C1 / C2	10	105	115	30/50	M 10 x 73	17	25 x 3	25
FAZ II 10/30 GS	—	501408	●	C1 / C2	10	105	115	30/50	M 10 x 73	17	25 x 3	50
FAZ II 12/10 GS	096303	501414	●	C1 / C2	12	100	110	10/30	M 12 x 61	19	30 x 3	20
FAZ II 12/20 GS	502530	—	●	C1 / C2	12	110	120	20/40	M 12 x 71	19	30 x 3	20
FAZ II 12/30 GS	096340	501418	●	C1 / C2	12	120	130	30/50	M 12 x 81	19	30 x 3	20
FAZ II 12/50 GS	502531	—	●	C1 / C2	12	140	150	50/70	M 12 x 101	19	30 x 3	20
FAZ II 12/80 GS	538430	—	●	C1 / C2	12	170	180	80/100	M 12 x 131	19	44 x 4	20
FAZ II 12/100 GS	502532	—	●	C1 / C2	12	190	200	100/120	M 12 x 151	19	30 x 3	20
FAZ II 12/100 GS	538702	—	●	C1 / C2	12	190	200	100/120	M 12 x 151	19	44 x 4	20
FAZ II 12/120 GS	096367	—	●	C1 / C2	12	210	220	120/140	M 12 x 171	19	30 x 3	20
FAZ II 12/120 GS	538703	—	●	C1 / C2	12	210	220	120/140	M 12 x 171	19	44 x 4	20
FAZ II 12/140 GS	538433	—	●	C1 / C2	12	230	240	140/160	M 12 x 186	19	44 x 4	20
FAZ II 12/160 GS	538431	—	●	C1 / C2	12	250	260	160/180	M 12 x 186	19	44 x 4	20
FAZ II 12/160 GS	—	503181	●	—	12	250	260	160/180	M 12 x 186	19	44 x 4	20
FAZ II 12/180 GS	538434	—	●	C1 / C2	12	270	280	180/200	M 12 x 186	19	44 x 4	20
FAZ II 12/200 GS	538432	—	●	C1 / C2	12	290	300	200/220	M 12 x 186	19	44 x 4	20
FAZ II 16/160 GS	503261	—	●	C1 / C2	16	270	283	160/180	M 16 x 189	24	56 x 5	10
FAZ II 16/160 GS	—	503182	●	C1 / C2	16	270	283	160/180	M 16 x 100	24	56 x 5	4
FAZ II 16/200 GS	096370	—	●	—	16	310	323	200/220	M 16 x 189	24	56 x 5	10
FAZ II 12/100 HBS	522951	—	●	C1 / C2	12	190	205	100/120	M 12 x 151	19	58 x 6	20
FAZ II 12/120 HBS	522952	—	●	C1 / C2	12	210	225	120/140	M 12 x 171	19	58 x 6	20
FAZ II 16/160 HBS	522953	—	●	C1 / C2	16	270	278	160/180	M 16 x 189	24	68 x 6	10
FAZ II 16/200 HBS	522954	—	●	—	16	310	328	200/220	M 16 x 189	24	68 x 6	10

Accessories

Bolt anchor setting tool FA-ST II



FA-ST II

FA-ST II Set

Replacement spring

Item	Item No.	Contents	Matching anchor type	Sales unit [pcs]
FABS	077937	—	FAZ II, FBZ, FBN II for diameter from M6 - M12	1
FA-ST II M10	558790	SDS adapter; socket SW17	FAZ II M10, FBZ M10, FBN II M10, EXA M10	1
FA-ST II M12	558791	SDS adapter; socket SW19	FAZ II M12, FBZ M12, FBN II M12, EXA M12	1
FA-ST II M16	558792	SDS adapter; socket SW24	FAZ II M16, FBZ M16, FBN II M16, EXA M16	1
FA-ST II Set	558789	SDS adapter; socket SW17, SW19, SW24	FAZ II M10/M12/M16, FBZ M10/M12/M16, FBN II M10/M12/M16, EXA M10/M12/M16	1
FA-ST II spring	558793	Replacement spring	FA-ST II M10/M12/M16	5

Loads

Bolt anchor FAZ II

Permissible loads of a single anchor¹⁾ in normal concrete of strength class C20/25.
For the design the complete current assessment ETA-05/0069 has to be considered.

Type	Material/surface ²⁾	Effective anchorage depth h_{ef} [mm]	Minimum member thickness h_{min} [mm]	Installation torque T_{inst} [Nm]	Cracked concrete				Non-cracked concrete			
					Permissible tension (N_{perm}) and shear loads (V_{perm}); minimum spacing (s_{min}) and edge distances (c_{min}) with reduced loads				Permissible tension (N_{perm}) and shear loads (V_{perm}); minimum spacing (s_{min}) and edge distances (c_{min}) with reduced loads			
					$N_{perm}^{3)}$ [kN]	$V_{perm}^{3)}$ [kN]	$s_{min}^{3)}$ [mm]	$c_{min}^{3)}$ [mm]	$N_{perm}^{3)}$ [kN]	$V_{perm}^{3)}$ [kN]	$s_{min}^{3)}$ [mm]	$c_{min}^{3)}$ [mm]
FAZ II 6	gvz	40	90	8	0.7	3.4	35	45	3.6	3.4	35	45
	R	40	90	8	0.7	5.0	35	45	5.0	5.0	35	45
FAZ II 8	gvz	35	80	20	2.6	7.8	35	40	4.9	7.8	40	40
	gvz	45	90	20	3.8	7.8	35	40	6.7	7.8	40	40
	R	35	80	20	2.6	8.5	35	40	4.9	9.6	40	40
	R	45	90	20	3.8	9.6	35	40	6.7	9.6	40	40
FAZ II 10	gvz	40	90	45	4.1	10.8	40	45	5.9	12.2	40	45
	gvz	60	110	45	6.2	12.2	40	45	9.5	12.2	40	45
	R	40	90	45	4.1	12.2	40	45	5.9	15.1	40	45
	R	60	110	45	6.2	15.1	40	45	9.5	15.1	40	45
FAZ II 12	gvz	50	100	60	5.8	17.5	50	55	8.3	17.5	50	55
	gvz	70	120	60	9.5	17.5	50	55	10.5	17.5	50	55
	R	50	100	60	5.8	18.0	50	55	8.3	21.9	50	55
	R	70	120	60	9.5	21.9	50	55	10.5	21.9	50	55
FAZ II 16	gvz	65	140	110	8.6	27.5	65	65	12.3	31.4	65	65
	gvz	85	140	110	12.9	31.4	65	65	18.4	31.4	65	65
	R	65	140	110	8.6	27.5	65	65	12.3	36.8	65	65
	R	85	140	110	12.9	38.6	65	65	18.4	39.9	65	65
FAZ II 20	gvz	100	170	200	16.4	42.6	95	85	23.4	46.5	95	95
	R	100	170	200	16.4	42.6	95	85	23.4	60.7	95	95
FAZ II 24	gvz	125	210	270	22.9	55.0	100	100	32.7	62.9	100	135
	R	125	210	270	22.9	55.0	100	100	32.7	78.6	100	135

¹⁾ Design according to EN 1992-4:2018 (for static resp. quasi-static loads). The partial safety factors for material resistance as regulated in the ETA as well as a partial safety factor for load actions of $\gamma_L = 1.4$ are considered. As a single anchor counts e.g. an anchor with a spacing $s \geq 3 \times h_{ef}$ and an edge distance $c \geq 1.5 \times h_{ef}$. Accurate data see ETA.

²⁾ Further steel grades, versions and technical data see ETA, e.g. for dry internal conditions, galvanised steel (gvz); for damp interiors and for outdoor use, stainless steel (R).

³⁾ In the case of combinations of tension and shear loads, bending moments with reduced or minimum spacing and edge distances (anchor groups), the design must be carried out in accordance with the provisions of the complete ETA and the provisions of the EN 1992-4:2018. We recommend using our anchor design software C-FIX.

High performance anchor FH II

Strong, secure and aesthetic anchoring

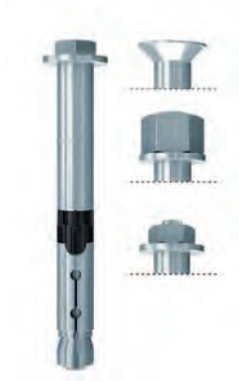

Steel girders



Banisters

Applications

- Guard rails
- Staircases
- Consoles
- Steel constructions
- Ladders
- Cable trays
- Machines
- Gates
- Façades
- Gratings

Advantages

- The international approvals guarantee maximum safety and the best performance. These approvals even cover use in earthquake zones (seismic C1 and C2).
- The anchor is designed with different head styles for fixing points with aesthetic design.
- The design between the bolt and the

- sleeve ensures high shear load-bearing capacity. Thus, fewer fixing points are required.
- The optimised geometry minimises the energy required for installation and thus allows for fast installation.
- The use of hollow drills is included in the approval.

Certificates



ETA-07/0025, for cracked concrete



from M10



Fire resistance classification R120



ICC ESR-2691



INOX STAINLESS STEEL



M8 - M20



Building materials

- Concrete C20/25, cracked and non-cracked

Versions

- Zinc-plated steel
- Stainless steel R

Functioning

- The FH II is suitable for push-through installation.
- When the torque is applied, the cone is pulled into the expansion sleeve which is forced against the drill hole wall.
- The black plastic ring prevents rotation when tightening the anchor and acts as a crumple zone to take the torque slip-page, so that the fixture of pulled onto the substrate.
- Alternative head designs for flexible design solutions:
Hexagon head (type S), countersunk head (type SK), bolt version with nut and washer (type B) and cap nut (type H).

Installation FH II

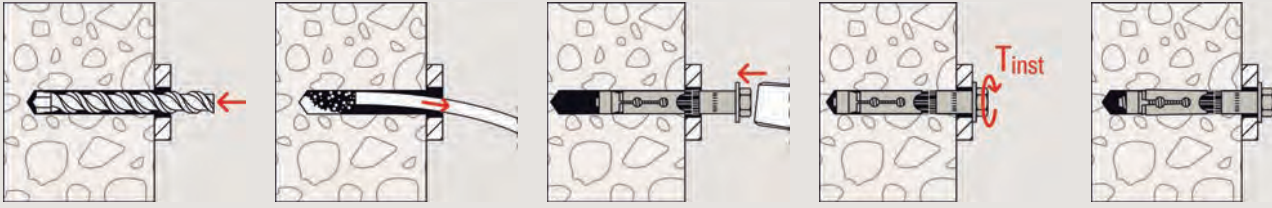

4

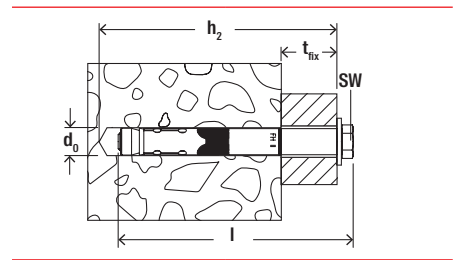

Technical data

High performance anchor FH II-S



FH II-S with hexagonal head

Item	Zinc-plated steel	Stainless steel	Approval		Seis-mic-Ap-proval	Drill hole diameter	Min. drill hole depth for through fixings	Anchor length	Max. fixture thickness	Thread	Width across nut	Sales unit
	Item No.	Item No.	ETA	ICC		d_0 [mm]	h_2 [mm]	l [mm]	t_{fix} [mm]	M	SW [mm]	[pcs]
	gvz	R										
FH II 10/10 S	503133	—	●	●	—	10	65	70	10	M 6	10	50
FH II 10/10 S	—	510923	●	●	—	10	65	69	10	M 6	10	50
FH II 10/25 S	503134	—	●	●	—	10	80	75	25	M 6	10	50
FH II 10/25 S	—	510924	●	●	—	10	80	84	25	M 6	10	50
FH II 10/50 S	503135	—	●	●	—	10	105	110	50	M 6	10	50
FH II 12/10 S	044884	—	●	●	C1 / C2	12	90	90	10	M 8	13	50
FH II 12/10 S	—	510925	●	●	C1 / C2	12	90	90	10	M 8	13	50
FH II 12/25 S	044885	—	●	●	C1 / C2	12	105	105	25	M 8	13	50
FH II 12/25 S	—	510926	●	●	C1 / C2	12	105	105	25	M 8	13	20
FH II 12/50 S	044886	—	●	●	C1 / C2	12	130	130	50	M 8	13	25
FH II 15/10 S	044887	—	●	●	C1 / C2	15	100	106	10	M 10	17	25
FH II 15/10 S	—	510927	●	●	C1 / C2	15	100	107	10	M 10	17	50
FH II 15/25 S	044888	—	●	●	C1 / C2	15	115	121	25	M 10	17	25
FH II 15/25 S	—	510928	●	●	C1 / C2	15	115	122	25	M 10	17	20
FH II 15/50 S	044889	—	●	●	C1 / C2	15	140	146	50	M 10	17	25
FH II 18/10 S	046847	—	●	●	C1 / C2	18	115	118	10	M 12	19	20
FH II 18/25 S	044894	—	●	●	C1 / C2	18	130	132	25	M 12	19	20
FH II 18/25 S	—	510929	●	●	C1 / C2	18	130	133	25	M 12	19	10
FH II 18/50 S	044896	—	●	●	C1 / C2	18	155	157	50	M 12	19	20
FH II 24/25 S	044898	—	●	●	C1 / C2	24	150	160	25	M 16	24	10
FH II 24/25 S	—	502711	●	●	C1 / C2	24	150	160	25	M 16	24	8
FH II 24/50 S	044900	—	●	●	C1 / C2	24	175	185	50	M 16	24	10
FH II 28/30 S	044901	—	●	●	C1 / C2	28	185	192	30	M 20	30	4
FH II 28/60 S	044902	—	●	●	C1 / C2	28	215	222	60	M 20	30	4
FH II 32/30 S	044903	—	●	●	C1 / C2	32	210	215	30	M 24	36	4
FH II 32/60 S	044904	—	●	●	C1 / C2	32	240	245	60	M 24	36	4

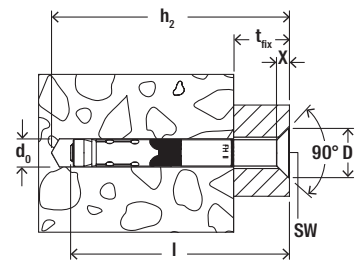

	X [mm]	Ø D [mm]
FH II 10/... SK	5,0	19,5
FH II 12/... SK	5,8	22
FH II 15/... SK	5,8	25
FH II 18/... SK	8,0	32

Technical data

High performance anchor FH II-SK



FH II-SK with countersunk head

Item	Zinc-plated steel	Stainless steel	Approval		Seismic-Approval	Drill hole diameter d ₀ [mm]	Min. drill hole depth for through fixings h ₂ [mm]	Anchor length l [mm]	Max. fixture thickness t _{fix} [mm]	Thread M	Width across nut (hexagon socket) SW [mm]	Sales unit [pcs]
	Item No. gvz	Item No. R	ETA	ICC								
FH II 10/15 SK	503136	—	●	●	—	10	70	65	15	M 6	4	50
FH II 10/25 SK	503137	—	●	●	—	10	80	75	25	M 6	4	50
FH II 10/50 SK	503138	—	●	●	—	10	105	100	50	M 6	4	50
FH II 12/15 SK	044917	510931	●	●	C1 / C2	12	95	90	15	M 8	5	25
FH II 12/25 SK	044918	—	●	●	C1 / C2	12	105	100	25	M 8	5	25
FH II 12/30 SK	—	510932	●	●	C1 / C2	12	110	105	30	M 8	5	25
FH II 12/50 SK	044919	510933	●	●	C1 / C2	12	130	125	50	M 8	5	25
FH II 15/15 SK	044920	510934	●	●	C1 / C2	15	105	100	15	M 10	6	25
FH II 15/25 SK	044921	—	●	●	C1 / C2	15	115	110	25	M 10	6	25
FH II 15/50 SK	044922	—	●	●	C1 / C2	15	140	135	50	M 10	6	25
FH II 18/15 SK	044923	—	●	●	C1 / C2	18	120	115	15	M 12	8	20
FH II 18/25 SK	044924	—	●	●	C1 / C2	18	130	125	25	M 12	8	20
FH II 18/30 SK	—	510935	●	●	C1 / C2	18	135	130	30	M 12	8	20
FH II 18/50 SK	044925	—	●	●	C1 / C2	18	155	150	50	M 12	8	20

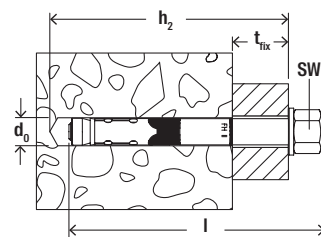

Technical data

High performance anchor FH II-H



FH II-H with cap nut

Item	Zinc-plated steel	Approval		Seismic-Approval	Drill hole diameter	Min. drill hole depth for through fixings	Anchor length	Max. fixture thickness	Thread	Width across nut	Sales unit
	Item No.	ETA	ICC		d_0 [mm]	h_2 [mm]	l [mm]	t_{fix} [mm]	M	SW [mm]	[pcs]
	gvz										
FH II 10/10 H	503139	●	●	—	10	65	75	10	M 6	13	50
FH II 10/25 H	503140	●	●	—	10	80	90	25	M 6	13	50
FH II 10/50 H	503141	●	●	—	10	105	115	50	M 6	13	50
FH II 12/10 H	044905	●	●	C1 / C2	12	90	100	10	M 8	17	50
FH II 12/25 H	044906	●	●	C1 / C2	12	105	115	25	M 8	17	50
FH II 12/50 H	044907	●	●	C1 / C2	12	130	140	50	M 8	17	25
FH II 15/10 H	044908	●	●	C1 / C2	15	100	115	10	M 10	17	25
FH II 15/25 H	044909	●	●	C1 / C2	15	115	130	25	M 10	17	25
FH II 15/50 H	044910	●	●	C1 / C2	15	140	155	50	M 10	17	25
FH II 18/25 H	044915	●	●	C1 / C2	18	130	145	25	M 12	19	20
FH II 18/50 H	044916	●	●	C1 / C2	18	155	170	50	M 12	19	20

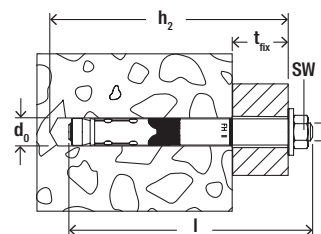

Technical data

High performance anchor FH II-B



FH II-B with hexagon nut and threaded bolt

Item	Zinc-plated steel	Approval		Seismic-Approval	Drill hole diameter	Min. drill hole depth for through fixings	Anchor length	Max. fixture thickness	Thread	Width across nut	Sales unit
	Item No.	ETA	ICC		d_0 [mm]	h_2 [mm]	l [mm]	t_{fix} [mm]	M	SW [mm]	[pcs]
	gvz										
FH II 10/10 B	503142	●	●	—	10	65	70	10	M 6	10	50
FH II 10/25 B	503143	●	●	—	10	80	75	25	M 6	10	50
FH II 10/50 B	503144	●	●	—	10	105	110	50	M 6	10	50
FH II 12/10 B	048773	●	●	C1 / C2	12	90	95	10	M 8	13	50
FH II 12/100 B	046832	●	●	C1 / C2	12	180	185	100	M 8	13	25
FH II 12/25 B	048774	●	●	C1 / C2	12	105	110	25	M 8	13	50
FH II 12/50 B	048775	●	●	C1 / C2	12	130	135	50	M 8	13	25
FH II 15/10 B	048776	●	●	C1 / C2	15	100	110	10	M 10	17	25

1) Delivery time on request.

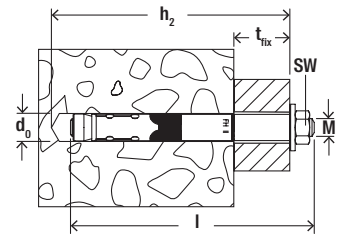

Technical data

High performance anchor FH II-B



FH II-B with hexagon nut and threaded bolt

Item	Zinc-plated steel	Approval		Seismic-Approval	Drill hole diameter d_0 [mm]	Min. drill hole depth for through fixings h_2 [mm]	Anchor length l [mm]	Max. fixture thickness t_{fix} [mm]	Thread M	Width across nut SW [mm]	Sales unit [pcs]
	Item No.	ETA	ICC								
FH II 15/100 B	046835	●	●	C1 / C2	15	190	200	100	M 10	17	20
FH II 15/25 B	048777	●	●	C1 / C2	15	115	125	25	M 10	17	25
FH II 15/50 B	048778	●	●	C1 / C2	15	140	150	50	M 10	17	25
FH II 18/100 B	046841	●	●	C1 / C2	18	205	215	100	M 12	19	10
FH II 18/25 B	048779	●	●	C1 / C2	18	130	140	25	M 12	19	20
FH II 18/50 B	048780	●	●	C1 / C2	18	155	165	50	M 12	19	20
FH II 24/100 B	046842	●	●	C1 / C2	24	225	242	100	M 16	24	5
FH II 24/25 B	048886	●	●	C1 / C2	24	150	167	25	M 16	24	10
FH II 24/50 B	048887	●	●	C1 / C2	24	175	192	50	M 16	24	10
FH II 28/100 B	506630 ¹⁾	●	●	—	28	255	271	100	M 20	30	4
FH II 28/30 B	047547	●	●	C1 / C2	28	185	199	30	M 20	30	4
FH II 28/60 B	047548	●	●	C1 / C2	28	215	229	60	M 20	30	4
FH II 32/30 B	047549	●	●	C1 / C2	32	210	231	30	M 24	36	4
FH II 32/60 B	047550	●	●	C1 / C2	32	240	261	60	M 24	36	4

1) Delivery time on request.

Loads

High performance anchor FH II

Permissible loads of a single anchor¹⁾ in normal concrete of strength class C20/25.
For the design the complete current assessment ETA-07/0025 has to be considered.

Type	Material/ surface ²⁾	Effective anchorage depth h_{ef} [mm]	Minimum member thickness h_{min} [mm]	Instal- lation torque T_{inst} [Nm]	Cracked concrete				Non-cracked concrete			
					Permissible tension (N_{perm}) and shear loads (V_{perm}); minimum spacing (s_{min}) and edge distances (c_{min}) with reduced loads				Permissible tension (N_{perm}) and shear loads (V_{perm}); minimum spacing (s_{min}) and edge distances (c_{min}) with reduced loads			
					$N_{perm}^{3)}$ [kN]	$V_{perm}^{3)}$ [kN]	$s_{min}^{3)}$ [mm]	$c_{min}^{3)}$ [mm]	$N_{perm}^{3)}$ [kN]	$V_{perm}^{3)}$ [kN]	$s_{min}^{3)}$ [mm]	$c_{min}^{3)}$ [mm]
FH II 10 S	gvz	40	80	10	3.6	4.1	40	40	5.9	5.9	40	40
	R	40	80	15	3.6	4.1	40	40	5.9	5.9	40	40
FH II 12 S	gvz	60	120	22.5	5.7	15.2	50	50	10.9	18.9	60	60
	R	60	120	25	5.7	15.2	50	50	9.5	17.7	60	60
FH II 15 S	gvz	70	140	40	7.6	19.2	60	60	13.7	27.4	70	70
	R	70	140	40	7.6	19.2	60	60	13.7	27.4	70	70
FH II 18 S	gvz	80	160	80	11.7	23.5	70	70	16.8	33.5	80	80
	R	80	160	100	11.7	23.5	70	70	16.8	33.5	80	80
FH II 24 S	gvz	100	200	160	16.4	32.8	80	80	23.4	46.9	100	100
	R	100	200	160	16.4	32.8	80	80	23.4	46.9	100	100
FH II 28 S	gvz	125	250	180	22.9	45.8	100	100	32.8	65.9	120	120
FH II 32 S	gvz	150	300	200	30.1	60.2	120	120	43.0	86.1	160	180
FH II 10 SK	gvz	40	80	10	3.6	4.1	40	40	5.9	5.9	40	40
FH II 12 SK	gvz	60	120	22.5	5.7	15.2	50	50	10.9	18.9	60	60
	R	60	120	25	5.7	15.2	50	50	10.9	18.9	60	60
FH II 15 SK	gvz	70	140	40	7.6	19.2	60	60	13.7	27.4	70	70
	R	70	140	40	7.6	19.2	60	60	13.7	27.4	70	70
FH II 18 SK	gvz	80	160	80	11.7	23.5	70	70	16.8	33.5	80	80
	R	80	160	100	11.7	23.5	70	70	16.8	33.5	80	80
FH II 10 H	gvz	40	80	10	3.6	4.1	40	40	5.9	5.9	40	40
FH II 12 H	gvz	60	120	22.5	5.7	15.2	50	50	10.9	15.5	60	60
FH II 15 H	gvz	70	140	40	7.6	19.2	60	60	13.7	24.5	70	70
FH II 18 H	gvz	80	160	80	11.7	23.5	70	70	16.8	33.5	80	80
FH II 10 B	gvz	40	80	10	3.6	4.1	40	40	5.9	5.9	40	40
FH II 12 B	gvz	60	120	17.5	5.7	15.2	50	50	10.9	15.5	60	60
FH II 15 B	gvz	70	140	38	7.6	19.2	60	60	13.7	24.5	70	70
FH II 18 B	gvz	80	160	80	11.7	23.5	70	70	16.8	33.5	80	80
FH II 24 B	gvz	100	200	120	16.4	32.8	80	80	23.4	46.9	100	100
FH II 28 B	gvz	125	250	180	22.9	45.8	100	100	32.7	65.5	120	120
FH II 32 B	gvz	150	300	200	30.1	60.2	120	120	43.0	86.1	160	180

¹⁾ Design according to EN 1992-4:2018 (for static resp. quasi-static loads). The partial safety factors for material resistance as regulated in the ETA as well as a partial safety factor for load actions of $\gamma_L = 1.4$ are considered. As a single anchor counts e.g. an anchor with a spacing $s \geq 3 \times h_{ef}$ and an edge distance $c \geq 1.5 \times h_{ef}$. Accurate data see ETA.

²⁾ Further steel grades, versions and technical data see ETA, e.g. for dry internal conditions, galvanised steel (gvz); for damp interiors and for outdoor use, stainless steel (R).

³⁾ In the case of combinations of tension and shear loads, bending moments with reduced or minimum spacing and edge distances (anchor groups), the design must be carried out in accordance with the provisions of the complete ETA and the provisions of the EN 1992-4:2018. We recommend using our anchor design software C-FIX.

High performance anchor FH II-I

Strong, secure and aesthetic with internal thread for the removal option of the attachment



Stadium seating



Air conditioning units

Applications

- Steel constructions
- Guard rails
- Consoles
- Ladders
- Cable trays
- Machines
- Staircases
- Pipeline routes
- Ventilation systems
- Sprinkler systems

Advantages

- The international approvals guarantee maximum safety and the best performance.
- The internal threaded anchor allows the removal of the attachment and the fixing point can be reused.
- The design between the bolt and the

- sleeve ensures high shear load-bearing capacity. Thus, fewer fixing points are required.
- The optimised geometry intelligently reduces the energy required for assembly.
- The approval regulates the use of hollow drills.

Certificates



ETA-07/0025, for cracked concrete



Fire resistance classification R120



INOX STAINLESS STEEL



M8 - M12

Building materials

- Approved for:
- Concrete C20/25 to C50/60, cracked and non-cracked
- Also suitable for:
- Concrete C12/15
 - Natural stone with dense structure

Versions

- Zinc-plated steel
- Stainless steel R

Functioning

- The FH II-I is suitable for pre-positioned installation.
- When a hexagon wrench is used for installation, the internal thread bolt starts to rotate. This pulls the cone into the expansion sleeve and expands it against the drill-hole wall. At the same time, the anchor is tightened through compression of the black plastic ring. A gap U to the concrete surface is created (see image 4).
- The anchor is set according to the approval when the gap U is 3-5 mm. Alternatively, an installation torque of T_{inst} can also be applied.

Installation FH II-I

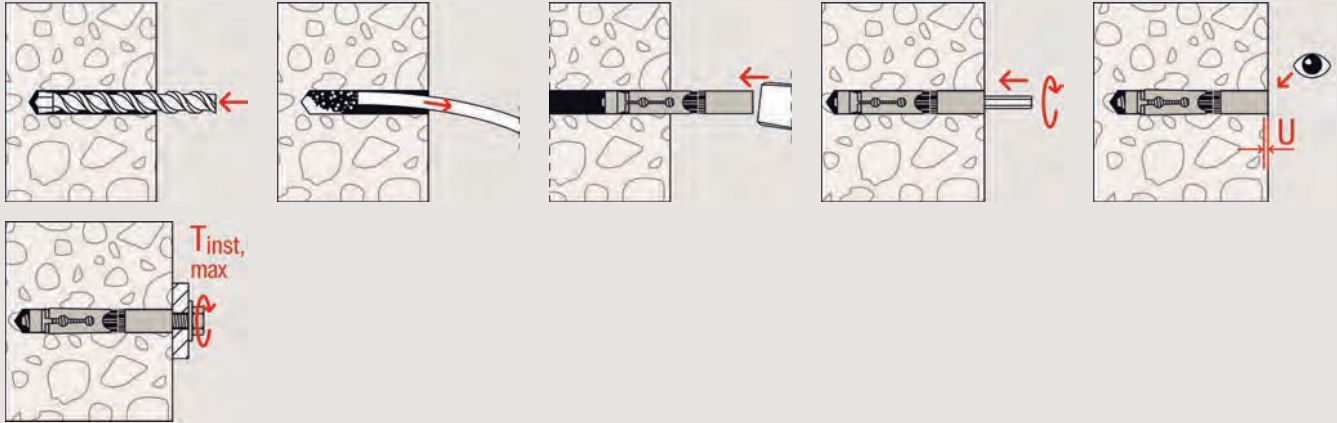

4

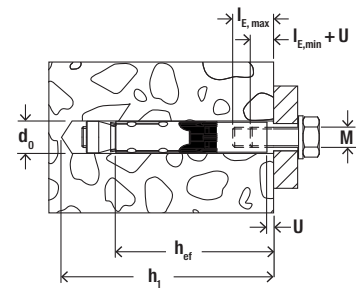

Technical data

High performance anchor FH II-I



FH II-I

Item	Zinc plated, steel grade 8.8	Stainless steel	Approval	Drill hole diameter	Min. drill hole depth for pre-positioned installation	Anchor length	Thread	Min. bolt penetration	Max. bolt penetration	Sales unit
	Item No. gvz	Item No. R	ETA	d_0 [mm]	h_1 [mm]	l [mm]	M	$l_{E,min}$ [mm]	$l_{E,max}$ [mm]	[pcs]
FH II 12/M6 I	520358	520360	●	12	85	77.5	M 6	11 + U	25	25
FH II 12/M8 I	520359	520361	●	12	85	77.5	M 8	13 + U	25	25
FH II 15/M10 I	519014	519018	●	15	95	90	M 10	10 + U	25	25
FH II 15/M12 I	519015	519019	●	15	95	90	M 12	12 + U	25	20

Technical data

Setting tool FH II-I



Setting tool FH II-I

Item	Item No.	Matching anchor type	Sales unit [pcs]
Setting tool FH II-I M6-M10	532780	FH II 12/M6 I, FH II 15/M 10 I	10
Setting tool FH II-I M8-M12	532781	FH II 12/M8 I, FH II 15/M 12 I	10

Loads

High performance anchor FH II-I

Permissible loads of a single anchor¹⁾ in normal concrete of strength class C20/25.
For the design the complete current assessment ETA-07/0025 has to be considered.

Type	Material/surface ²⁾	Screw material ²⁾	Effective anchorage depth h_{ef} [mm]	Minimum member thickness h_{min} [mm]	Installation torque T_{inst} [Nm]	Cracked concrete				Non-cracked concrete			
						Permissible tension (N_{perm}) and shear loads (V_{perm}); minimum spacing (s_{min}) and edge distances (c_{min}) with reduced loads				Permissible tension (N_{perm}) and shear loads (V_{perm}); minimum spacing (s_{min}) and edge distances (c_{min}) with reduced loads			
						$N_{perm}^{3)}$ [kN]	$V_{perm}^{3)}$ [kN]	$s_{min}^{3)}$ [mm]	$c_{min}^{3)}$ [mm]	$N_{perm}^{3)}$ [kN]	$V_{perm}^{3)}$ [kN]	$s_{min}^{3)}$ [mm]	$c_{min}^{3)}$ [mm]
FH II 12 / M6 I	gvz	5.8	60	125	15	4.3	2.9	50	50	4.8	2.9	60	60
	gvz	8.8	60	125	15	4.3	4.6	50	50	7.6	4.6	60	60
	R	A4-70	60	125	15	4.3	3.2	50	50	5.3	3.2	60	60
FH II 12 / M8 I	gvz	5.8	60	125	15	4.3	5.1	50	50	9.0	5.1	60	60
	gvz	8.8	60	125	15	4.3	8.0	50	50	9.5	8.0	60	60
	R	A4-70	60	125	15	4.3	6.0	50	50	9.5	6.0	60	60
FH II 15 / M10 I	gvz	5.8	70	150	25	5.7	8.6	60	60	13.7	8.6	70	70
	gvz	8.8	70	150	25	5.7	13.1	60	60	13.7	13.1	70	70
	R	A4-70	70	150	25	5.7	9.2	60	60	13.7	9.2	70	70
FH II 15 / M12 I	gvz	5.8	70	150	25	5.7	12.0	60	60	13.7	12.0	70	70
	gvz	8.8	70	150	25	5.7	13.7	60	60	13.7	13.7	70	70
	R	A4-70	70	150	25	5.7	13.7	60	60	13.7	13.7	70	70

¹⁾ Design according to EN 1992-4:2018 (for static resp. quasi-static loads). The partial safety factors for material resistance as regulated in the ETA as well as a partial safety factor for load actions of $\gamma_L = 1.4$ are considered. As a single anchor counts e.g. an anchor with a spacing $s \geq 3 \times h_{ef}$ and an edge distance $c \geq 1.5 \times h_{ef}$. Accurate data see ETA.

²⁾ Further steel grades, versions and technical data see ETA, e.g. for dry internal conditions, galvanised steel (gvz); for damp interiors and for outdoor use, stainless steel (R).

³⁾ In the case of combinations of tension and shear loads, bending moments with reduced or minimum spacing and edge distances (anchor groups), the design must be carried out in accordance with the provisions of the complete ETA and the provisions of the EN 1992-4:2018. We recommend using our anchor design software C-FIX.

ZYKON undercut anchor FZA

The fixing system with the highest safety in cracked concrete



Steel girders

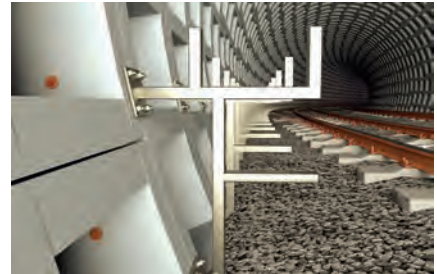

Installations in tunnels

4

Applications

- Steelwork constructions
- Guard rails
- Consoles
- Step irons (FZA-ST)
- Ladders
- Cable trays
- Machines
- Staircases
- Gates
- Façades

Advantages

- The special ZYKON undercut technology allows for a positive fit connection and ensures maximum safety, even in large cracks.
- The almost expansion-free installation of the anchor allows small edge distances and axial spacing, and thereby enables flexible use.
- The FZUB special drill allows for a fast in-

stallation by creating the undercut without having to change tools.

- The drill hole geometry allows for a very low setting energy, thus reducing the energy required for installation.
- The ideal interaction of threaded bolts and sleeve with FZA-D allows for a high shear load and therefore fewer fixing points.

Certificates



ETA-98/0004, for cracked concrete



Fire resistance classification R120



INOX STAINLESS STEEL



from M8



from M10



Building materials

Approved for:

- Concrete C20/25 to C50/60, cracked and non-cracked

Also suitable for:

- Concrete C12/15
- Natural stone with dense structure

Versions

- Zinc-plated steel
- Stainless steel R

Functioning

- The FZA and FZA-I is suitable for pre-positioned installation, whereas the FZA-D is suitable for push-through installation.
- The undercut drill hole is created using the special FZUB drill.
- Once the anchor has been placed in the drill hole, the expansion sleeve is driven over the cone using the FZE Plus setting tool, and the undercut drill hole is filled with a positive fit.

Pre-positioned installation FZA

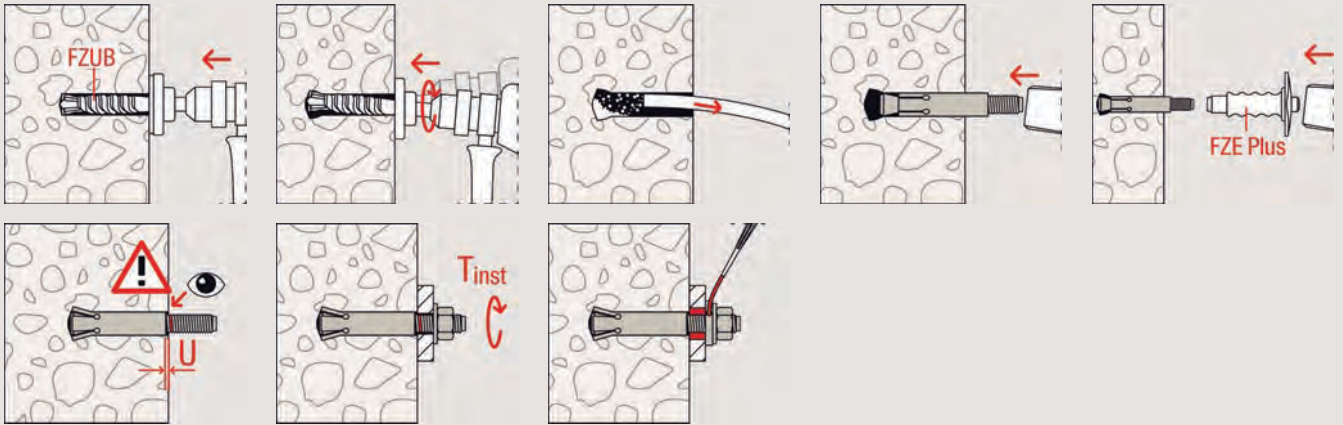

Push-through installation FZA-D

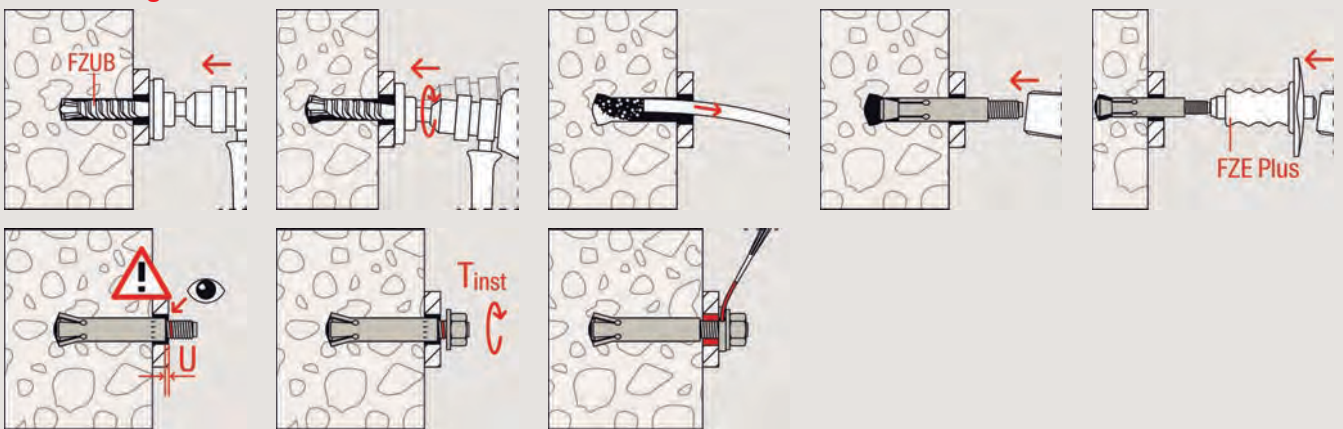

Installation FZA-ST

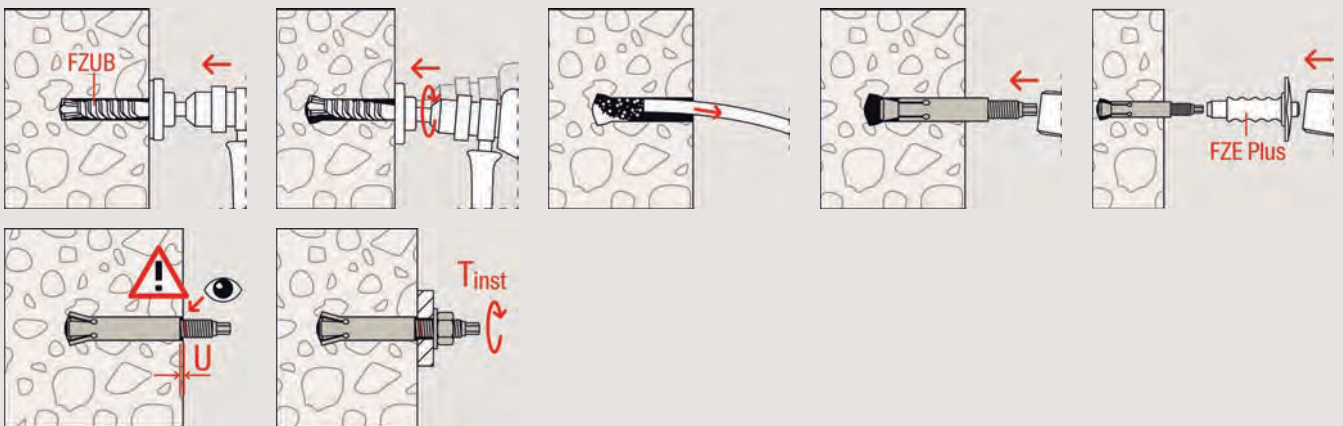

Installation FZA-I

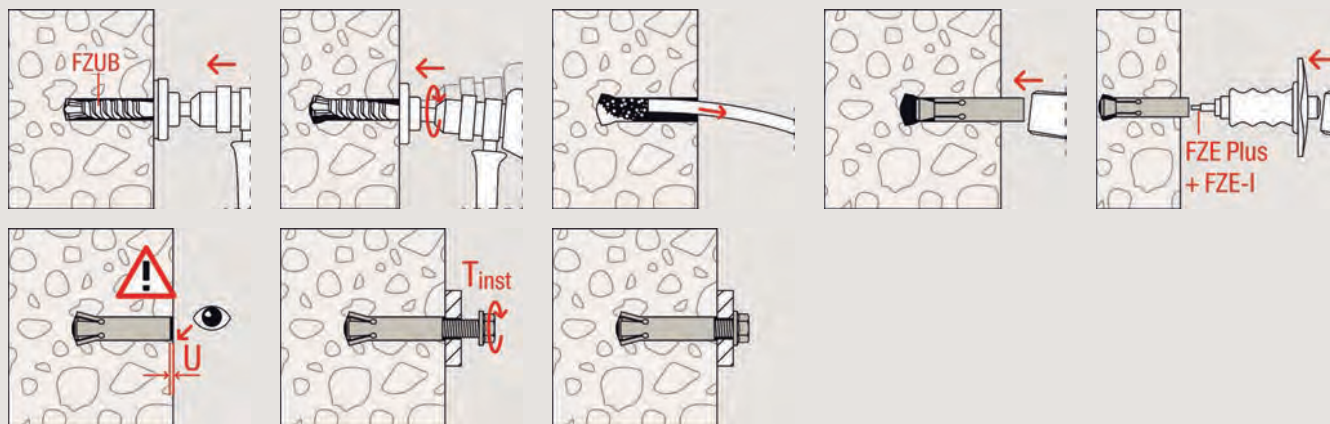

4

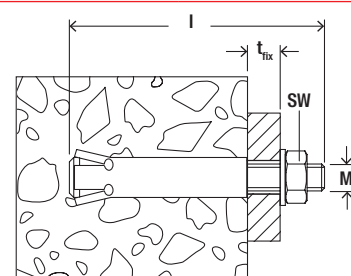

Technical data

ZYKON undercut anchor FZA



FZA

Item	Zinc-plated steel	Stainless steel	Approval	Seismic-Approval	Required drill bit FZUB	Required setting tool FZE plus	Bolt length l [mm]	Max. fixture thickness t _{fix} [mm]	Thread M	Width across nut SW [mm]	Sales unit [pcs]
	Item No. gvz	Item No. R	ETA								
FZA 10 x 40 M6/10	060712	060772	●	—	10 x 40	FZE 10 plus	60	10	M 6	10	25
FZA 12 x 40 M 8/15	060715	060775	●	—	12 x 40	FZE 12 plus	69	15	M 8	13	25
FZA 12 x 50 M 8/15	060716	060776	●	—	12 x 50	FZE 12 plus	79	15	M 8	13	20
FZA 12 x 50 M 8/50	—	060774	●	—	12 x 50	FZE 12 plus	114	50	M 8	13	20
FZA 14 x 40 M10/25	060718	—	●	C2	14 x 40	FZE 14 plus	79	25	M 10	17	25
FZA 14 x 40 M10/25	—	060778	●	C2	14 x 40	FZE 14 plus	79	25	M 10	17	20
FZA 14 x 60 M10/25	060719	060779	●	C2	14 x 60	FZE 14 plus	102	25	M 10	17	10
FZA 14 x 60 M10/50	—	060766	●	C2	14 x 60	FZE 14 plus	126	50	M 10	17	10
FZA 18 x 80 M12/25	060721	060781	●	C2	18 x 80	FZE 18 plus	126	25	M 12	19	10
FZA 18 x 80 M12/55	—	060767	●	C2	18 x 80	FZE 18 plus	156	55	M 12	19	10
FZA 22 x 100 M16/60	060724	060782	●	C2	22 x 100	FZE 22 plus	184	60	M 16	24	10
FZA 22 x 125 M16/60	060725	060768	●	C2	22 x 125	FZE 22 plus	209	60	M 16	24	6

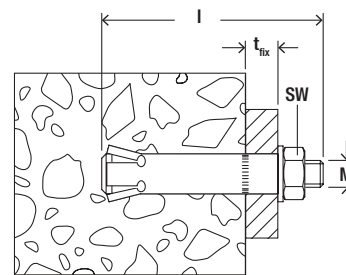

Technical data

ZYKON undercut anchor FZA-D



FZA-D

Item	Zinc-plated steel	Stainless steel	Approval	Seis-mic-Approval	Required drill bit FZUB	Required setting tool FZE plus	Bolt length	Max. fixture thickness	Thread	Width across nut	Sales unit
	Item No.	Item No.					l [mm]	t _{fix} [mm]	M	SW [mm]	[pcs]
	gvz	R	ETA								
FZA 12 x 50 M 8 D/10	060652	060664	●	—	12 x 50	FZE 12 plus	69	10	M 8	13	25
FZA 12 x 60 M 8 D/10	060653	060665	●	—	12 x 60	FZE 12 plus	79	10	M 8	13	25
FZA 12 x 80 M 8 D/30	060654	060666	●	—	12 x 80	FZE 12 plus	99	30	M 8	13	25
FZA 14 x 80 M10 D/20	060657	060669	●	C2	14 x 80	FZE 14 plus	102	20	M 10	17	10
FZA 14 x 100 M 8 D/30	060658	060670	●	C2	14 x 100	FZE 14 plus	126	30	M 10	17	10
FZA 18 x 100 M12 D/20	060684	060672	●	C2	18 x 100	FZE 18 plus	126	20	M 12	19	10
FZA 18 x 130 M12 D/50	060685	060673	●	C2	18 x 130	FZE 18 plus	156	50	M 12	19	10
FZA 22 x 125 M16 D/25	060663	060675	●	C2	22 x 125	FZE 22 plus	156	25	M 16	24	10

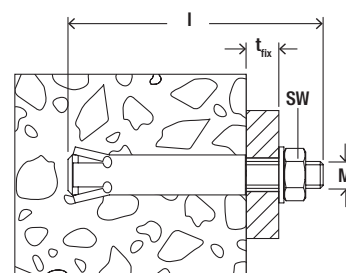

Technical data

ZYKON anchor for fixing step irons FZA-ST R



FZA ST R

Item	Item No.	Required drill bit FZUB	Required setting tool FZE plus	Max. fixture thickness t _{fix} [mm]	Thread	Width across nut	Sales unit
					M	SW [mm]	[pcs]
	R						
FZA 14 x 40 STR	060686 ¹⁾	14 x 40	FZE 14 plus	30	M 10	16	20
FZA 14 x 60 STR	060687 ¹⁾	14 x 60	FZE 14 plus	30	M 10	16	20

1) According to DIN 1211GS/1212GS.

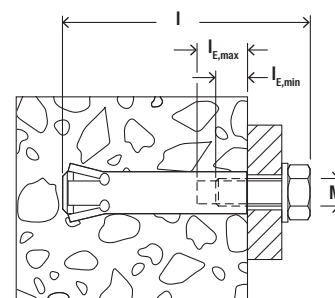

Technical data

ZYKON undercut anchor FZA-I

4



FZA-I

Item	Zinc-plated steel	Stainless steel	Approval	Required drill bit FZUB	Required setting tool FZE plus	Internal thread	Min. bolt penetration	Max. bolt penetration	Sales unit
	Item No.	Item No.	ETA			M	$l_{E,min}$ [mm]	$l_{E,max}$ [mm]	[pcs]
FZA 12 x 40 M6 I	060758	060783	●	12 x 40	FZE 12 plus	M 6	10	15	25
FZA 12 x 50 M6 I	—	060784	●	12 x 50	FZE 12 plus	M 6	10	15	25
FZA 14 x 60 M8 I	060760	060786	●	14 x 60	FZE 14 plus	M 8	11	17	20
FZA 18 x 80 M10 I	060761	060787	●	18 x 80	FZE 18 plus	M 10	13	21	10
FZA 22 x 100 M12 I	060763	060788	●	22 x 100	FZE 22 plus	M 12	15	25	10
FZA 22 x 125 M12 I	060769	060770 ¹⁾	●	22 x 125	FZE 22 plus	M 12	15	25	10

1) Delivery time on request.

Technical data

Drill bit FZUB



FZUB

Item	Item No.	fits anchor			Sales unit [pcs]
		bolt anchor	push-through anchor	internal thread anchor	
FZUB 10 x 40	060622	FZA 10 x 40 M6			1
FZUB 12 x 40	060623	FZA 12 x 40 M8		FZA 12 x 40 M6 I	1
FZUB 14 x 40	060624	FZA 14 x 40 M10			1
FZUB 12 x 60	060625		FZA 12 x 60 M8 D/10		1
FZUB 12 x 80	060626		FZA 12 x 80 M8 D/30		1
FZUB 12 x 50	060627	FZA 12 x 50 M8	FZA 12 x 50 M8 D/10	FZA 12 x 50 M6 I	1
FZUB 14 x 60	060628	FZA 14 x 60 M10		FZA 14 x 60 M8 I	1
FZUB 14 x 80	060629		FZA 14 x 80 M10 D/20		1
FZUB 14 x 100	060630		FZA 14 x 100 M10 D/40		1
FZUB 18 x 100	060632		FZA 18 x 100 M12 D/20		1
FZUB 18 x 130	060633		FZA 18 x 130 M12 D/50		1
FZUB 18 x 80	060634	FZA 18 x 80 M12		FZA 18 x 80 M10 I	1
FZUB 22 x 100	060636	FZA 22 x 100 M16		FZA 22 x 100 M12 I	1
FZUB 22 x 125	060638	FZA 22 x 125 M16	FZA 22 x 125 M16 D/25	FZA 22 x 125 M12 I	1

Technical data

Setting tool FZE plus



FZE plus

Item	Item No.	fits anchor bolt anchor	push-through anchor	internal thread anchor	Sales unit [pcs]
FZE 10 plus	044637 ¹⁾	FZA 10 x ... M6			1
FZE 12 plus	044638	FZA 12 x ... M8	FZA 12 x ... M8 D	FZA 12 x ... M6 I	1
FZE 14 plus	044639	FZA 14 x ... M10	FZA 14 x ... M10 D	FZA 14 x ... M8 I	1
FZE 18 plus	044640	FZA 18 x ... M12	FZA 18 x ... M12 D	FZA 18 x ... M10 I	1
FZE 22 plus	044641	FZA 22 x ... M16	FZA 22 x ... M16 D	FZA 22 x ... M12 I	1

1) Without centring pin.

Loads

ZYKON undercut anchor FZA

Permissible loads of a single anchor¹⁾ in normal concrete of strength class C20/25.
For the design the complete current assessment ETA-98/0004 has to be considered.

Type	Material/ surface ²⁾	Effective anchorage depth h_{ef} [mm]	Minimum member thickness h_{min} [mm]	Instal- lation torque T_{inst} [Nm]	Cracked concrete				Non-cracked concrete			
					Permissible tension (N_{perm}) and shear loads (V_{perm}); minimum spacing (s_{min}) and edge distances (c_{min}) with reduced loads				Permissible tension (N_{perm}) and shear loads (V_{perm}); minimum spacing (s_{min}) and edge distances (c_{min}) with reduced loads			
					$N_{perm}^{3)}$ [kN]	$V_{perm}^{3)}$ [kN]	$s_{min}^{3)}$ [mm]	$c_{min}^{3)}$ [mm]	$N_{perm}^{3)}$ [kN]	$V_{perm}^{3)}$ [kN]	$s_{min}^{3)}$ [mm]	$c_{min}^{3)}$ [mm]
FZA 10 x 40 M6	gvz	40	100	8.5	2.4	5.0	40	35	4.8	5.0	40	35
	R	40	100	8.5	2.4	4.2	40	35	4.8	4.2	40	35
FZA 12 x 40 M8	gvz	40	100	20	2.4	5.4	40	40	4.8	7.7	40	40
	R	40	100	20	2.4	5.4	40	40	4.8	7.6	40	40
FZA 12 x 50 M8	gvz	50	110	20	4.3	7.5	50	45	8.3	9.2	50	45
	R	50	110	20	4.3	7.5	50	45	8.3	7.6	50	45
FZA 14 x 40 M10	gvz	40	100	40	2.4	10.0	70	70	4.8	14.2	70	70
	R	40	100	40	2.4	10.0	70	70	4.8	12.1	70	70
FZA 14 x 60 M10	gvz	60	130	40	5.7	14.6	60	55	10.9	14.6	60	55
	R	60	130	40	5.7	12.1	60	55	10.9	12.1	60	55
FZA 18 x 80 M12	gvz	80	160	60	11.4	21.2	80	70	16.8	21.2	80	70
	R	80	160	60	11.4	17.6	80	70	16.8	17.6	80	70
FZA 22 x 100 M16	gvz	100	200	100	16.4	39.5	100	100	23.4	39.5	100	100
	R	100	200	100	16.4	35.2	100	100	23.4	35.2	100	100
FZA 22 x 125 M16	gvz	125	250	100	19.0	39.5	125	125	32.7	39.5	125	125
	R	125	250	100	19.0	35.2	125	125	32.7	35.2	125	125

¹⁾ Design according to EN 1992-4:2018 (for static resp. quasi-static loads). The partial safety factors for material resistance as regulated in the ETA as well as a partial safety factor for load actions of $\gamma_L = 1.4$ are considered. As a single anchor counts e.g. an anchor with a spacing $s \geq 3 \times h_{ef}$ and an edge distance $c \geq 1.5 \times h_{ef}$. Accurate data see ETA.

²⁾ Further steel grades, versions and technical data see ETA, e.g. for dry internal conditions, galvanised steel (gvz); for damp interiors and for outdoor use, stainless steel (R).

³⁾ In the case of combinations of tension and shear loads, bending moments with reduced or minimum spacing and edge distances (anchor groups), the design must be carried out in accordance with the provisions of the complete ETA and the provisions of the EN 1992-4:2018. We recommend using our anchor design software C-FIX.

Loads

ZYKON internally-threaded anchor FZA-I

Permissible loads of a single anchor¹⁾ in normal concrete of strength class C20/25.
For the design the complete current assessment ETA-98/0004 has to be considered.

Type	Material/ surface ²⁾	Screw material	Effective anchor- age depth h_{ef} [mm]	Mini- mum member thick- ness h_{min} [mm]	Instal- lation torque T_{inst} [Nm]	Cracked concrete				Non-cracked concrete			
						Permissible tension (N_{perm}) and shear loads (V_{perm}); minimum spacing (s_{min}) and edge distances (c_{min}) with reduced loads				Permissible tension (N_{perm}) and shear loads (V_{perm}); minimum spacing (s_{min}) and edge distances (c_{min}) with reduced loads			
						$N_{perm}^{3)}$ [kN]	$V_{perm}^{3)}$ [kN]	$s_{min}^{3)}$ [mm]	$c_{min}^{3)}$ [mm]	$N_{perm}^{3)}$ [kN]	$V_{perm}^{3)}$ [kN]	$s_{min}^{3)}$ [mm]	$c_{min}^{3)}$ [mm]
FZA 12 x 40 M6 I	gvz	8.8	40	100	8.5	2.4	4.1	40	35	4.8	4.1	40	35
	R	A4-70	40	100	8.5	2.4	3.2	40	35	4.8	3.2	40	35
FZA 12 x 50 M6 I	R	A4-70	50	110	8.5	4.3	3.2	50	45	5.4	3.2	50	45
	gvz	8.8	60	130	15	5.7	5.4	60	55	9.3	5.4	60	55
FZA 14 x 60 M8 I	R	A4-70	60	130	15	5.7	4.3	60	55	7.1	4.3	60	55
	gvz	8.8	80	160	30	9.6	5.6	80	70	9.6	5.6	80	70
FZA 18 x 80 M10 I	R	A4-70	80	160	30	9.0	5.4	80	70	9.0	5.4	80	70
	gvz	8.8	100	200	60	16.4	13.2	100	100	22.5	13.2	100	100
FZA 22 x 100 M12 I	R	A4-70	100	200	60	16.4	12.7	100	100	21.1	12.7	100	100
	gvz	8.8	125	250	60	19.0	13.2	125	125	22.5	13.2	125	125
FZA 22 x 125 M12 I	R	A4-70	125	250	60	19.0	12.7	125	125	21.1	12.7	125	125

¹⁾ Design according to EN 1992-4:2018 (for static resp. quasi-static loads). The partial safety factors for material resistance as regulated in the ETA as well as a partial safety factor for load actions of $\gamma_L = 1.4$ are considered. As a single anchor counts e.g. an anchor with a spacing $s \geq 3 \times h_{ef}$ and an edge distance $c \geq 1.5 \times h_{ef}$. Accurate data see ETA.

²⁾ Further steel grades, versions and technical data see ETA, e.g. for dry internal conditions, galvanised steel (gvz); for damp interiors and for outdoor use, stainless steel (R).

³⁾ In the case of combinations of tension and shear loads, bending moments with reduced or minimum spacing and edge distances (anchor groups), the design must be carried out in accordance with the provisions of the complete ETA and the provisions of the EN 1992-4:2018. We recommend using our anchor design software C-FIX.

Loads

ZYKON undercut anchor FZA-D

Permissible loads of a single anchor¹⁾ in normal concrete of strength class C20/25.
For the design the complete current assessment ETA-98/0004 has to be considered.

Type	Material/ surface ²⁾	Effective anchorage depth h_{ef} [mm]	Minimum member thickness h_{min} [mm]	Instal- lation torque T_{inst} [Nm]	Cracked concrete				Non-cracked concrete			
					Permissible tension (N_{perm}) and shear loads (V_{perm}); minimum spacing (s_{min}) and edge distances (c_{min}) with reduced loads				Permissible tension (N_{perm}) and shear loads (V_{perm}); minimum spacing (s_{min}) and edge distances (c_{min}) with reduced loads			
					$N_{perm}^{3)}$ [kN]	$V_{perm}^{3)}$ [kN]	$s_{min}^{3)}$ [mm]	$c_{min}^{3)}$ [mm]	$N_{perm}^{3)}$ [kN]	$V_{perm}^{3)}$ [kN]	$s_{min}^{3)}$ [mm]	$c_{min}^{3)}$ [mm]
FZA 12 x 50 M8 D	gvz	40	100	20	2.4	5.4	40	35	4.8	7.7	40	35
	R	40	100	20	2.4	5.4	40	35	4.8	7.7	40	35
FZA 12 x 60 M8 D	gvz	50	110	20	4.3	7.5	50	45	8.3	10.8	50	45
	R	50	110	20	4.3	7.5	50	45	8.3	10.8	50	45
FZA 14 x 80 M10 D	gvz	60	130	40	5.7	23.5	60	55	10.9	23.5	60	55
	R	60	130	40	5.7	16.1	60	55	10.9	16.1	60	55
FZA 18 x 100 M12 D	gvz	80	160	60	11.4	36.4	80	70	16.8	36.8	80	70
	R	80	160	60	11.4	36.4	80	70	16.8	40.4	80	70
FZA 22 x 125 M16 D	gvz	100	200	100	16.4	50.8	100	100	23.4	59.4	100	100
	R	100	200	100	16.4	50.8	100	100	24.4	64.6	100	100

¹⁾ Design according to EN 1992-4:2018 (for static resp. quasi-static loads). The partial safety factors for material resistance as regulated in the ETA as well as a partial safety factor for load actions of $\gamma_L = 1.4$ are considered. As a single anchor counts e.g. an anchor with a spacing $s \geq 3 \times h_{ef}$ and an edge distance $c \geq 1.5 \times h_{ef}$. Accurate data see ETA.

²⁾ Further steel grades, versions and technical data see ETA, e.g. for dry internal conditions, galvanised steel (gvz); for damp interiors and for outdoor use, stainless steel (R).

³⁾ In the case of combinations of tension and shear loads, bending moments with reduced or minimum spacing and edge distances (anchor groups), the design must be carried out in accordance with the provisions of the complete ETA and the provisions of the EN 1992-4:2018. We recommend using our anchor design software C-FIX.

ZYKON hammerset anchor FZEA II

The internally threaded anchor with low anchoring depth for individual fixings in cracked concrete



Emergency exit signs in tunnels



Air conditioning units

Applications

- Pipelines
- Ventilation systems
- Sprinkler systems
- Cable trays
- Suspended ceilings

Advantages

- Hammerset anchor with Zykon undercut technology for individual fixings in cracked and non-cracked concrete.
- The combination of hammerset and ZYKON undercut anchor allows for individual fixings in cracked concrete.
- The special ZYKON undercut technology reduces the energy required for installation.
- The FZUB special drill allows for a fast in-

stallation by creating the undercut without having to change tools.

- The embossing that is applied when expanding the anchor secures the simple control of the anchoring.
- The almost expansion-free installation of the anchor allows small edge distances and axial spacing, thereby enabling flexible use.

Certificates



ETA-06/0271, for cracked concrete



Fire resistance classification R120



from M10



INOX STAINLESS STEEL



M8 - M20

Building materials

Approved for:

- Concrete C20/25 to C50/60, cracked and non-cracked

Also suitable for:

- Concrete C12/15
- Natural stone with dense structure

Versions

- Zinc-plated steel
- Stainless steel R
- Highly corrosion-resistant steel HCR

Functioning

- The FZEA II is suitable for pre-positioned installation.
- The undercut drill hole is created using the special FZUB drill.
- Once the anchor has been placed in the drill hole, the expansion sleeve is expanded by the driving in of the internal expansion pin with the FZED Plus setting tool, and the undercut drill hole is filled with a positive fit.

Installation FZEA II

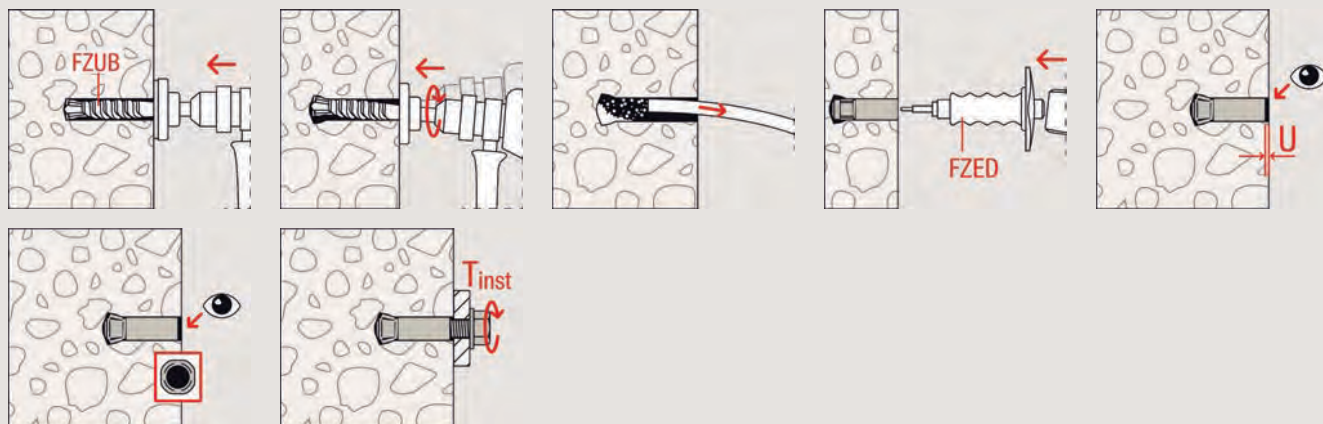

4

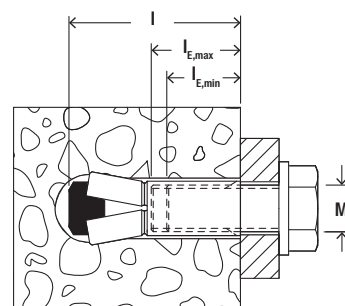

Technical data

ZYKON hammerset anchor FZEA II



FZEA II

	Zinc-plated steel	Stainless steel	Highly corrosion resistant steel	Approval	Required drill bit FZUB	Required setting tool FZED plus	Length L [mm]	Internal thread A1	Max. bolt penetration $l_{E,max}$ [mm]	Min. bolt penetration $l_{E,min}$ [mm]	Sales unit [pcs]
Item	Item No. gvz	Item No. R	Item No. HCR	ETA							
FZEA II 10 x 40 M 8	047303	047306	047309 ¹⁾	●	10 x 40	FZED 10 plus	43	M 8	17	11	100
FZEA II 12 x 40 M10	047304	047307	047310 ¹⁾	●	12 x 40	FZED 12 plus	43	M 10	19	13	100
FZEA II 14 x 40 M12	047305	047308	—	●	14 x 40	FZED 14 plus	43	M 12	21	15	50

1) Delivery on request.

Technical data

Drill bit FZUB



FZUB

Item	Item No.	Matching anchor type	Sales unit [pcs]
FZUB 10 x 40	060622	FZEA II 10 x 40, FZA 10 x 40 M6	1
FZUB 12 x 40	060623	FZEA II 12 x 40, FZA 12 x 40 M8	1
FZUB 14 x 40	060624	FZEA II 14 x 40, FZA 14 x 40	1

Technical data

Setting tool FZED plus



FZED plus

Item	Item No.	Matching anchor type	Sales unit [pcs]
FZED 10 plus	044642	FZEA II 10 x 40 M8	1
FZED 12 plus	044643	FZEA II 12 x 40 M10	1
FZED 14 plus	044644	FZEA II 14 x 40 M12	1

Loads

ZYKON hammer set anchor FZEA II

Permissible loads of a single anchor¹⁾ in normal concrete of strength class C20/25.
For the design the complete current assessment ETA-06/0271 has to be considered.

Type	Material/ surface ²⁾	Screw material	Effective anchor- age depth h_{ef} [mm]	Mini- mum member thick- ness h_{min} [mm]	Maxi- mum instal- lation torque $T_{inst,max}$ [Nm]	Cracked concrete				Non-cracked concrete			
						Permissible tension (N_{perm}) and shear loads (V_{perm}); minimum spacing (s_{min}) and edge distances (c_{min}) with reduced loads				Permissible tension (N_{perm}) and shear loads (V_{perm}); minimum spacing (s_{min}) and edge distances (c_{min}) with reduced loads			
						$N_{perm}^{3)}$ [kN]	$V_{perm}^{3)}$ [kN]	$s_{min}^{3)}$ [mm]	$c_{min}^{3)}$ [mm]	$N_{perm}^{3)}$ [kN]	$V_{perm}^{3)}$ [kN]	$s_{min}^{3)}$ [mm]	$c_{min}^{3)}$ [mm]
FZEA II 10 x 40 M8	gvz	5.8	40	80	10	1.6	4.1	40	40	3.6	4.7	40	40
	gvz	8.8	40	80	10	1.6	4.1	40	40	3.6	4.7	40	40
	R	A4-70	40	80	15	1.6	4.1	40	40	3.6	4.6	40	40
FZEA II 12 x 40 M10	gvz	5.8	40	80	15	3.0	4.1	45	45	3.6	5.9	45	45
	gvz	8.8	40	80	15	3.0	4.1	45	45	3.6	5.9	45	45
	R	A4-70	40	80	20	3.0	4.1	45	45	3.6	5.9	45	45
FZEA II 14 x 40 M12	gvz	5.8	40	80	20	3.5	4.1	50	50	3.6	5.9	50	50
	gvz	8.8	40	80	20	3.5	4.1	50	50	3.6	5.9	50	50
	R	A4-70	40	80	40	3.5	4.1	50	50	3.6	5.9	50	50

¹⁾ Design according to EN 1992-4:2018 (for static resp. quasi-static loads). The partial safety factors for material resistance as regulated in the ETA as well as a partial safety factor for load actions of $\gamma_L = 1.4$ are considered. As a single anchor counts e.g. an anchor with a spacing $s \geq 3 \times h_{ef}$ and an edge distance $c \geq 1.5 \times h_{ef}$. Accurate data see ETA.

²⁾ Further steel grades, versions and technical data see ETA, e.g. for dry internal conditions, galvanised steel (gvz); for damp interiors and for outdoor use, stainless steel (R).

³⁾ In the case of combinations of tension and shear loads, bending moments with reduced or minimum spacing and edge distances (anchor groups), the design must be carried out in accordance with the provisions of the complete ETA and the provisions of the EN 1992-4:2018. We recommend using our anchor design software C-FIX.

Concrete screw UltraCut FBS II 8-14

The high-performance concrete screw for absolute installation ease

4

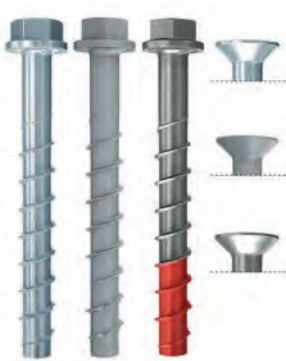

Banisters



Inclined supports

Applications

- Guard rails
- Consoles/base plates
- Metal profiles
- Steel constructions
- Façades
- Protection barriers
- Results/beam anchors
- Shuttering props (only FBS II zinc-plated steel)
- Temporary anchoring, e.g. of building site equipment (only FBS II zinc-plated steel)
- Concrete-concrete connections (e.g. strengthening of bridges, parking garages or renovation of buildings)

Advantages

- With up to 3 embedment depths, the UltraCut FBS II allows for the same screw to be used for different component thicknesses.
- Unique saw-tooth geometry cuts quickly into the concrete - also in multiple use and reinforced concrete.
- The performance categories seismic C1 and C2 ensure that the strictest of safety standards and earthquake specifications can be fulfilled.
- In comparison to the usually available systems (with mortar) for the reinforcement

of existing concrete structures, the ETA-certified FBS II system with the optional setting tool SC-ST saves time and costs.

- The high coating quality of the FBS II CP is proved through the salt spray chamber test over 2,000h.
- For the zinc-plated steel version the checking gauge allows for reuse covered by the approval.
- The specially hardened red tip of the stainless steel R version provides faster and more secure installation.

Certificates



ETA-15/0352, for cracked concrete
ETA-17/0740, for cracked concrete
ETA-20/0321, for strengthening of existing concrete structures by concrete overlay



Fire resistance classification R120



INOX STAINLESS STEEL

Building materials

Approved for:

- Concrete C20/25 to C50/60, cracked and non-cracked
- Strengthening of existing concrete structures with top layer concrete

Also suitable for:

- Concrete C12/15
- Solid building materials
- Masonry with dense structure

Versions

- Zinc-plated steel
- Stainless steel R
- Corrosion protection coating (CP)

Functioning

- The UltraCut FBS II is recommended for the push-through installation.
- Drill holes do not need to be cleaned during vertical installation (ceiling and floor). For floor fixings the hole must be drilled 3x drill hole diameter deeper.
- The approved adjustment for the concrete screws allows the screw to be unscrewed twice for a total length of 20 mm, to place maximum 10 mm packing below the base plates or to align the attached part.
- We recommend using the fischer impact wrench FSS 18V with a suitable impact screwdriver socket or an internal torx drive.
- The screw is installed correctly when the screw head sits flush on the fixture (visual setting control).
- For the installation of restructuring of existing concrete structures by concrete overlay, the setting tool SC-ST can be used for a faster installation.

Installation UltraCut FBS II

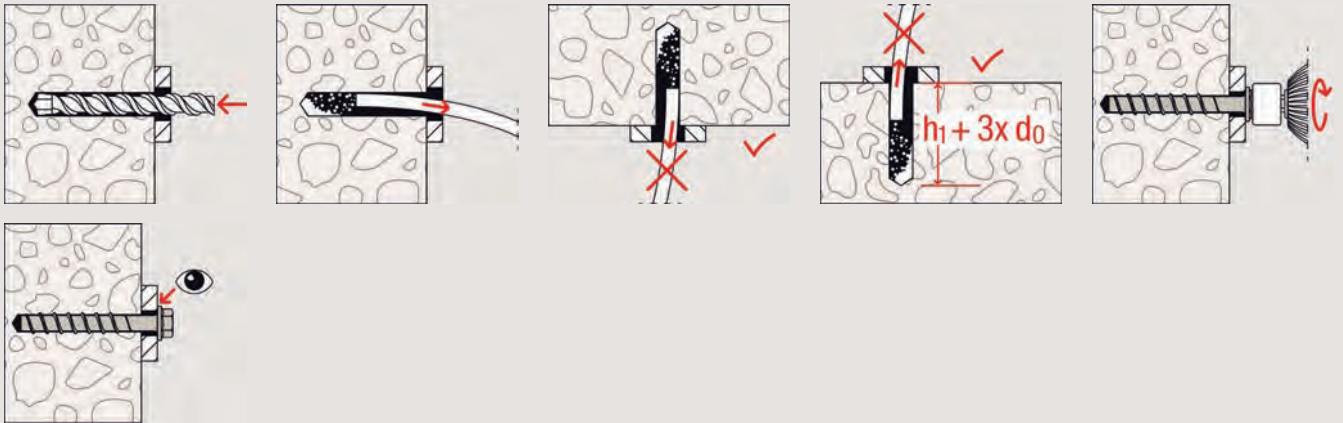

4

Fixture adjustment

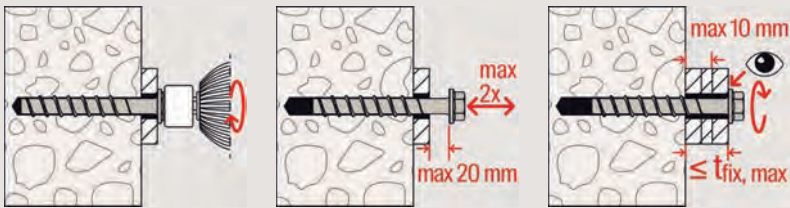

Additional for seismic applications

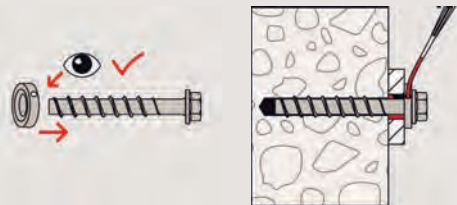

Installation UltraCut FBS II (concrete-concrete connection)

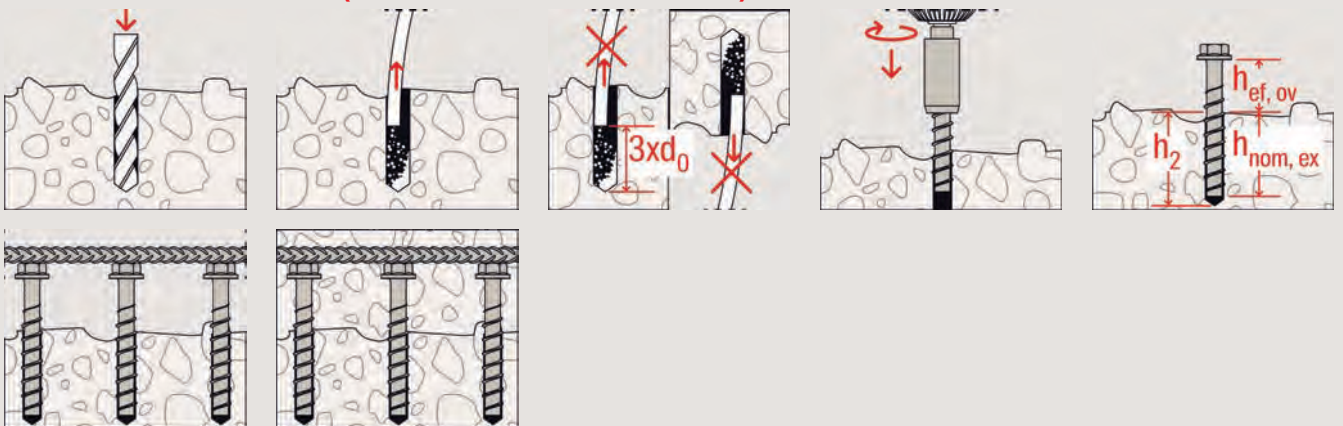

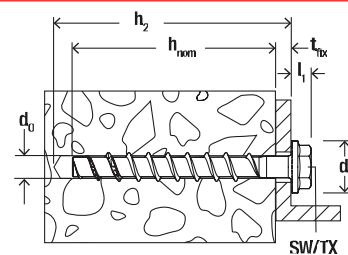

Technical data

Concrete screw UltraCut FBS II US



UltraCut FBS II US

UltraCut FBS II CP US

Item	Zinc-plated steel	Corrosion protection coating	Approval	Drill hole diameter	Min. drill hole depth for through fixings	Screw	Screw-in depth with fixture thickness	Screw-in depth with fixture thickness	Screw-in depth with fixture thickness	Drive	Sales unit
	Item No.	Item No.	ETA	d_0 [mm]	h_2 [mm]	$d_a \times l_s$ [mm]	h_{nom1} / t_{fix} [mm]	h_{nom2} / t_{fix} [mm]	h_{nom3} / t_{fix} [mm]		[pcs]
Item	gvz	CP									
FBS II 8x55 5/- US TX	536851	557781	●	8	65	10 x 55	50 / 5	- / -	- / -	TX40/SW13	50
FBS II 8x70 20/5 US TX	536852	557782	●	8	80	10 x 70	50 / 20	- / -	65 / 5	TX40/SW13	50
FBS II 8x80 30/15 US TX	536853	557783	●	8	90	10 x 80	50 / 30	- / -	65 / 15	TX40/SW13	50
FBS II 8x90 40/25 US TX	536854	557784	●	8	100	10 x 90	50 / 40	- / -	65 / 25	TX40/SW13	50
FBS II 8x100 50/35 US TX	536855	557785	●	8	110	10 x 100	50 / 50	- / -	65 / 35	TX40/SW13	50
FBS II 8x110 60/45 US TX	536856	—	●	8	120	10 x 110	50 / 60	- / -	65 / 45	TX40/SW13	50
FBS II 8x130 80/65 US TX	536857	—	●	8	140	10 x 130	50 / 80	- / -	65 / 65	TX40/SW13	50
FBS II 8x150 100/85 US TX	558219	—	●	8	160	10 x 150	50 / 100	- / -	65 / 85	TX40/SW13	50
FBS II 8x170 120/105 US TX	558220	—	●	8	180	12 x 60	50 / 120	- / -	65 / 105	TX40/SW13	50
FBS II 8x190 140/125 US TX	558221	—	●	8	200	10 x 190	50 / 140	- / -	65 / 125	TX40/SW13	50
FBS II 10x60 5/-/- US	536858	557786	●	10	70	12 x 60	55 / 5	- / -	- / -	SW 15	50
FBS II 10x70 15/5/- US	536859	557787	●	10	80	12 x 70	55 / 15	65 / 5	- / -	SW 15	50
FBS II 10x80 25/15/- US	536860	557788	●	10	90	12 x 80	55 / 25	65 / 15	- / -	SW 15	50
FBS II 10x90 35/25/5 US	536861	557789	●	10	100	12 x 90	55 / 35	65 / 25	85 / 5	SW 15	50
FBS II 10x100 45/35/15 US	536862	557790	●	10	110	12 x 100	55 / 45	65 / 35	85 / 15	SW 15	50
FBS II 10x120 65/55/35 US	536863	557791	●	10	130	12 x 120	55 / 65	65 / 55	85 / 35	SW 15	50
FBS II 10x140 85/75/55 US	536864	557792	●	10	150	12 x 140	55 / 85	65 / 75	85 / 55	SW 15	50
FBS II 10x160 105/95/75 US	536865	557793	●	10	170	12 x 160	55 / 105	65 / 95	85 / 75	SW 15	50
FBS II 10x200 145/135/115 US	536866	—	●	10	210	12 x 200	55 / 145	65 / 135	85 / 115	SW 15	20
FBS II 10x230 175/165/145 US	536867	—	●	10	240	12 x 230	55 / 175	65 / 165	85 / 145	SW 15	20
FBS II 10x260 205/195/175 US	536868	—	●	10	270	12 x 260	55 / 205	65 / 195	85 / 175	SW 15	20
FBS II 10x280 225/215/195 US	558222	—	●	10	290	12 x 280	55 / 225	65 / 215	85 / 195	SW 15	20
FBS II 12x70 10/-/- US	536869	—	●	12	80	14 x 70	60 / 10	- / -	- / -	SW 17	20
FBS II 12x85 25/10/- US	536870	557794	●	12	95	14 x 85	60 / 25	75 / 10	- / -	SW 17	20
FBS II 12x110 50/35/10 US	536871	557795	●	12	120	14 x 110	60 / 50	75 / 35	100 / 10	SW 17	20
FBS II 12x130 70/55/30 US	536872	—	●	12	140	14 x 130	60 / 70	75 / 55	100 / 30	SW 17	20
FBS II 12x150 90/75/50 US	536873	—	●	12	160	14 x 150	60 / 90	75 / 75	100 / 50	SW 17	20
FBS II 12x170 110/95/70 US	558223	—	●	12	180	14 x 170	60 / 110	75 / 95	100 / 70	SW 17	20
FBS II 12x190 130/115/90 US	558224	—	●	12	200	14 x 190	60 / 130	75 / 115	100 / 90	SW 17	20
FBS II 12x210 150/135/110 US	558225	—	●	12	220	14 x 210	60 / 150	75 / 135	100 / 110	SW 17	20
FBS II 14x75 10/-/- US	536874	557796	●	14	90	16 x 75	65 / 10	- / -	- / -	SW 21	20
FBS II 14x95 30/10/- US	536875	557797	●	14	110	16 x 95	65 / 30	85 / 10	- / -	SW 21	20
FBS II 14x100 35/15/- US	536876	557798	●	14	115	16 x 100	65 / 35	85 / 15	- / -	SW 21	20
FBS II 14x125 60/40/10 US	536877	557799	●	14	140	16 x 125	65 / 60	85 / 40	115 / 10	SW 21	10
FBS II 14x150 85/65/35 US	536878	—	●	14	165	16 x 150	65 / 85	85 / 65	115 / 35	SW 21	10
FBS II 14x180 115/85/65 US	558226	—	●	14	192	16 x 180	65 / 115	85 / 95	115 / 65	SW 21	10
FBS II 14x210 145/125/95 US	558227	—	●	14	225	16 x 210	65 / 145	85 / 125	115 / 95	SW 21	10
FBS II 14x240 175/155/125 US	558228	—	●	14	255	16 x 240	65 / 175	85 / 155	115 / 125	SW 21	10

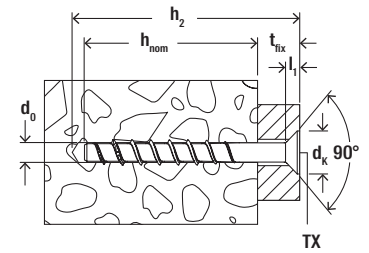

Technical data

Concrete screw UltraCut FBS II SK



UltraCut FBS II SK

UltraCut FBS II CP SK

Item	Zinc-plated steel	Corrosion protection coating	ETA	Drill hole diameter	Min. drill hole depth for through fixings	Screw	Screw-in depth with fixture thickness	Screw-in depth with fixture thickness	Screw-in depth with fixture thickness	Drive	Sales unit
	Item No.	Item No.	Approval	d_0 [mm]	h_2 [mm]	$d_a \times l_s$ [mm]	h_{nom1} / t_{fix} [mm]	h_{nom2} / t_{fix} [mm]	h_{nom3} / t_{fix} [mm]		[pcs]
FBS II 8x60 10/- SK	536880	557800	●	8	70	10 x 60	50 / 10	- / -	- / -	TX40	50
FBS II 8x80 30/15 SK	536881	557801	●	8	90	10 x 80	50 / 30	- / -	65 / 15	TX40	50
FBS II 8x90 40/25 SK	536882	557802	●	8	100	10 x 90	50 / 40	- / -	65 / 25	TX40	50
FBS II 8x100 50/35 SK	558229	—	●	8	110	10 x 100	50 / 50	- / -	65 / 35	TX40	50
FBS II 8x110 60/45 SK	558230	—	●	8	120	10 x 110	50 / 60	- / -	65 / 45	TX40	50
FBS II 8x120 70/55 SK	558231	—	●	8	130	10 x 120	50 / 70	- / -	65 / 55	TX40	50
FBS II 8x140 90/75 SK	558232	—	●	8	150	10 x 130	50 / 90	- / -	65 / 75	TX40	50
FBS II 8x160 110/95 SK	558233	—	●	8	170	10 x 150	50 / 110	- / -	65 / 95	TX40	50
FBS II 8x180 130/115 SK	558234	—	●	8	190	10 x 170	50 / 130	- / -	65 / 115	TX40	50
FBS II 8x200 150/135 SK	558235	—	●	8	210	10 x 190	50 / 150	- / -	65 / 135	TX40	50
FBS II 10x65 10/-/- SK	536884	557803	●	10	75	12 x 65	55 / 10	- / -	- / -	TX50	50
FBS II 10x80 25/15/- SK	536885	557804	●	10	90	12 x 80	55 / 25	65 / 15	- / -	TX50	50
FBS II 10x95 40/30/10 SK	536886	—	●	10	105	12 x 95	55 / 40	65 / 30	85 / 10	TX50	50
FBS II 10x100 45/35/15 SK	536887	557805	●	10	110	12 x 100	55 / 45	65 / 35	85 / 15	TX50	50
FBS II 10x120 65/55/35 SK	536888	—	●	10	130	12 x 120	55 / 65	65 / 55	85 / 35	TX50	50
FBS II 10x140 85/75/55 SK	558236	—	●	10	150	12 x 140	55 / 85	65 / 75	85 / 55	TX50	50
FBS II 10x160 105/95/75 SK	558237	—	●	10	170	12 x 160	55 / 105	65 / 95	85 / 75	TX50	50
FBS II 10x180 125/115/95 SK	558238	—	●	10	180	12 x 180	55 / 125	65 / 115	65 / 95	TX50	20

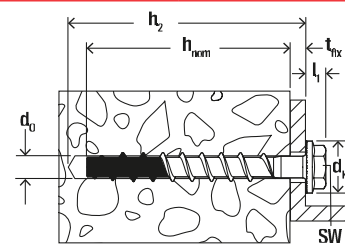

Technical data

Concrete screw UltraCut FBS II US R



UltraCut FBS II US R hexagon head with molded washer, stainless steel R

4

Item	Stainless steel	Approval	Drill hole diameter	Min. drill hole depth for through fixings	Screw length	Screw-in depth with fixture thickness	Screw-in depth with fixture thickness	Screw-in depth with fixture thickness	Drive	Sales unit
	Item No.		d_0 [mm]	h_2 [mm]	l_s [mm]	h_{nom1} / t_{fix} [mm]	h_{nom2} / t_{fix} [mm]	h_{nom3} / t_{fix} [mm]		[pcs]
FBS II 8x60 10/- US R	543565	●	8	70	60	50 / 10	- / -	- / -	SW 13	50
FBS II 8x70 20/5 US R	543566	●	8	80	70	50 / 20	- / -	65 / 5	SW 13	50
FBS II 8x80 30/15 US R	543567	●	8	90	80	50 / 30	- / -	65 / 15	SW 13	50
FBS II 8x90 40/25 US R	543568	●	8	100	90	50 / 40	- / -	65 / 25	SW 13	50
FBS II 8x100 50/35 US R	558239	●	8	110	100	50 / 50	- / -	65 / 35	SW 13	50
FBS II 8x120 70/55 US R	558240	●	8	130	120	50 / 70	- / -	65 / 55	SW 13	50
FBS II 8x140 90/75 US R	558241	●	8	150	140	50 / 90	- / -	65 / 75	SW 13	50
FBS II 8x160 110/95 US R	558242	●	8	170	160	50 / 110	- / -	65 / 95	SW 13	50
FBS II 10x60 5/-/- US R	543569	●	10	70	60	55 / 5	- / -	- / -	SW 15	50
FBS II 10x70 15/5/- US R	543570	●	10	80	70	55 / 15	65 / 5	- / -	SW 15	50
FBS II 10x80 25/15/- US R	543571	●	10	90	80	55 / 25	65 / 15	- / -	SW 15	50
FBS II 10x90 35/25/5 US R	543572	●	10	100	90	55 / 35	65 / 25	85 / 5	SW 15	50
FBS II 10x100 45/35/15 US R	543573	●	10	110	100	55 / 45	65 / 35	85 / 15	SW 15	50
FBS II 10x120 65/55/35 US R	543574	●	10	130	120	55 / 65	65 / 55	85 / 35	SW 15	50
FBS II 10x140 85/75/55 US R	558243	●	10	150	140	55 / 85	65 / 75	85 / 55	SW 15	50
FBS II 10x160 105/95/75 US R	558244	●	10	170	160	55 / 105	65 / 95	85 / 75	SW 15	50
FBS II 12x70 10/-/- US R	543575	●	12	80	70	60 / 10	- / -	- / -	SW 17	20
FBS II 12x85 25/10/- US R	543576	●	12	95	85	60 / 25	75 / 10	- / -	SW 17	20
FBS II 12x110 50/35/10 US R	543577	●	12	120	110	60 / 50	75 / 35	100 / 10	SW 17	20
FBS II 12x130 70/55/30 US R	543578	●	12	140	130	60 / 70	75 / 55	100 / 30	SW 17	20
FBS II 12x160 100/85/60 US R	558245	●	12	170	160	60 / 100	75 / 95	100 / 60	SW 17	20

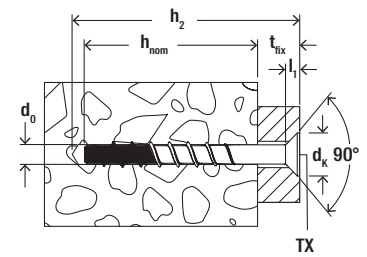

Technical data

Concrete screw UltraCut FBS II SK R



UltraCut FBS II SK R counter-sunk head, stainless steel R

Item	Stainless steel	Approval	Drill hole diameter	Min. drill hole depth for through fixings	Screw length	Screw-in depth with fixture thickness	Screw-in depth with fixture thickness	Screw-in depth with fixture thickness	Drive	Sales unit
	Item No.		d_0 [mm]	h_2 [mm]	l_s [mm]	h_{nom1} / t_{fix} [mm]	h_{nom2} / t_{fix} [mm]	h_{nom3} / t_{fix} [mm]		[pcs]
		ETA								
FBS II 8x60 10/- SK R	543579	●	8	70	60	50 / 10	- / -	- / -	TX40	50
FBS II 8x80 30/15 SK R	543580	●	8	90	80	50 / 30	- / -	65 / 15	TX40	50
FBS II 8x90 40/25 SK R	543581	●	8	100	90	50 / 40	- / -	65 / 25	TX40	50
FBS II 8x100 50/35 SK R	558246	●	8	110	100	50 / 50	- / -	65 / 35	TX40	50
FBS II 10x65 10/- SK R	543582	●	10	75	65	55 / 10	- / -	- / -	TX50	50
FBS II 10x80 25/15/- SK R	543583	●	10	90	80	55 / 25	65 / 15	- / -	TX50	50
FBS II 10x95 40/30/10 SK R	543584	●	10	105	95	55 / 40	65 / 30	85 / 10	TX50	50
FBS II 10x100 45/35/15 SK R	543585	●	10	110	100	55 / 45	65 / 35	85 / 15	TX50	50
FBS II 10x120 65/55/35 SK R	543586	●	10	130	120	55 / 65	65 / 55	85 / 35	TX50	50

Technical data

Accessories UltraCut FBS II



FUP



Nut SW



Nut TX 1/2" - 1/4"



FMB TX



FPB ProfiBit TX 50 5/16"



Setting tool SC-ST

Item	Item No.	Internal diameter D [mm]	Drive	Match	Sales unit [pcs]
FUP 8	537200	9,9	—	FBS II 8	1
FUP 10	537201	12,0	—	FBS II 10	1
FUP 12	537202	13,0	—	FBS II 12	1
FUP 14	537203	15,0	—	FBS II 14	1
Nut SW 10	538577	—	1/2" / SW10	FBS II 6	1
Nut SW 13	538578	—	1/2" / SW13	FBS II 8	1
Nut SW 15	538579	—	1/2" / SW15	FBS II 10	1
Nut SW 17	538580	—	1/2" / SW17	FBS II 12	1
Nut SW 21	538581	—	1/2" / SW21	FBS II 14	1
Nut 1/2" - 1/4"	553928	—	1/2" / 1/4"	FBS II 6 / FBS II 8 / FBS II 8 SK	1
Nut 1/2" - TX 50	553929	—	1/2" / TX50	FBS II 10 / FBS II 10 SK	1
FMB TX30 MaxxBit W 5	533158	—	TX30	FBS II 6	1
FMB TX40 MaxxBit W 5	533159	—	TX40	FBS II 6 / FBS II 8 / FBS II 8 SK	1
FPB TX 50 5/16" ProfiBit	557844	—	TX50	FBS II 10 SK	1
Setting tool SC-ST 8	557872	—	—	FBS II 8	1
Setting tool SC-ST 10	557874	—	—	FBS II 10	1

Technical data

Accessories UltraCut FBS II



FFD



FSW 10



Washer U

Item	Item No.	Internal diameter	External-Ø	Match	Sales unit
		D [mm]	d [mm]		[pcs]
Filling disc FFD 22 x 9 x 6	547515	9,0	22	FBS II 6	4
Filling disc FFD 26 x 12 x 6	538458	12,0	26	FBS II 8	4
Filling disc FFD 26 x 12 x 6 R	541986	12,0	26	FBS II 8 R / FBS II 10 R	4
Filling disc FFD 30 x 14 x 6	538459	14,0	30	FBS II 10 / FBS II 12	4
Filling disc FFD 30 x 14 x 6 R	541987	14,0	30	FBS II 10 R / FBS II 12 R	4
Filling disc FFD 38 x 19 x 7	538460	19	38	FBS II 14	4
Adjusting washer FSW 10	557276	17,5	44	FBS II 10 US	40
Washer for FBS 10	520471	13,5	44	FBS II 10 US	50

Installation data - concrete C20/25 - C50/60

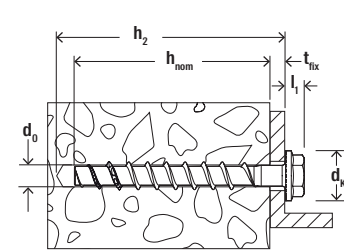

Type US

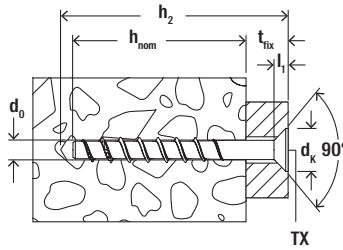

Type SK

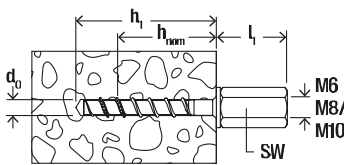

Type I

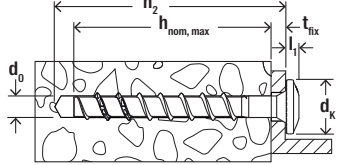

Type P / Typ LP

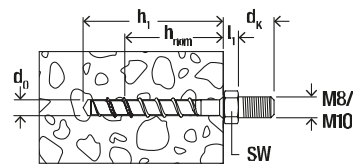

Type M8 / M10

UltraCut	FBS II 8		FBS II 10		FBS II 6			FBS II M8/M10		FBS II 6 I, M8/M10, M6
	SK	SK R	SK	SK R	SK	P	LP	US	3,6/5	15/16
l_1 [mm]	6,0	7,0	7,0	7,0	6,0	3,9	3,6	6,2	3,6/5	15/16
d_k [mm]	20,0	23,0	23,0	25,0	13,5	14,4	17,5	17,0	37,0/32	-
Concrete screw UltraCut FBS II 6-14 gvz / R					6	8	10	12	14	
Drill hole diameter		d_0	[mm]	6	8	10	12	14		
Nominal screw-in depth		$h_{nom 1}$	[mm]	25 - 55	50	55	60	65		
		$h_{nom 2}$	[mm]	25 - 55	-	65	75	85		
		$h_{nom 3}$	[mm]	25 - 55	65	85	100	115		
Drill hole depth (push-trough installation)		$h_2 \geq$	[mm]	$l + 10$	$l + 10$	$l + 10$	$l + 10$	$l + 15$		
Clearance hole diameter		d_f	[mm]	≤ 8	10,6 - 12	12,8 - 14	14,8 - 16	16,9 - 18		
Maximum torque for installation with impact screw driver in concrete ³⁾		$t_{imp, max gvz}$	[Nm]	450 ¹⁾	600	650	650	650		
		$t_{imp, max R}$	[Nm]	-	450	450	650	-		
Width across flat		SW		10 ²⁾	13	15	17	21		
Drive		TX		T30	T40 (SK u. US)	T50 (SK)	-	-		

1) Screw-in depth < 35 mm 80 Nm

2) SW 13 for FBS II ... M10 and FBS II ... M8/M10 I

3) The values apply to concrete strength of approx. 40 N/mm², for other concrete strength classes the values may differ. The conversion of nominal output into effective tightening torque varies from machine to machine - always therefore use torque control.

Installation data masonry

Concrete screw ULTRACUT FBS II 8-14					
Building material	Compressive strength class	Size	[mm]	8	10
	[N/mm ²]	h_{nom}	[mm]	65	85
Solid clay brick (EN771-1)	≥ 12	T_{inst}	I + 10	10	10
Solid sand-lime brick (EN771-2)	≥ 12	T_{instt}	≤ 8	15	15
Aerated concrete (EN771-4)	≥ 6	T_{ins}	T30	5	5

Loads

Concrete screw Ultracut FBS II US hexagon head with integral washer and FBS II SK countersunk head

4

Permissible loads of a single anchor¹⁾ in normal concrete of strength class C20/25.
For the design the complete current assessment ETA-15/0352 has to be considered.

Type	Material/ surface	Screw-in depth h_{nom} [mm]	Minimum member thickness h_{min} [mm]	Instal- lation torque $T_{imp, max}$ ²⁾ [Nm]	Cracked concrete				Non-cracked concrete			
					Permissible tension (N_{perm}) and shear loads (V_{perm}); minimum spacing (s_{min}) and edge distances (c_{min}) with reduced loads				Permissible tension (N_{perm}) and shear loads (V_{perm}); minimum spacing (s_{min}) and edge distances (c_{min}) with reduced loads			
					N_{perm} ³⁾ [kN]	V_{perm} ³⁾ [kN]	s_{min} ³⁾ [mm]	c_{min} ³⁾ [mm]	N_{perm} ³⁾ [kN]	V_{perm} ³⁾ [kN]	s_{min} ³⁾ [mm]	c_{min} ³⁾ [mm]
FBS II 6	gvz	40	80	450	1.2	4.3	35	35	3.8	4.3	35	35
	gvz	45	90	450	1.7	4.3	35	35	4.8	4.3	35	35
	gvz	50	90	450	1.9	4.3	35	35	5.7	4.3	35	35
	gvz	55	100	450	2.4	6.3	35	35	6.4	6.3	35	35
FBS II 8	gvz / CP	50	100	600	2.9	4.1	35	35	5.9	5.9	35	35
	gvz / CP	65	120	600	5.7	9.0	35	35	8.8	9.0	35	35
FBS II 10	gvz / CP	55	100	650	4.3	4.6	40	40	6.6	6.6	40	40
	gvz / CP	65	120	650	5.7	11.9	40	40	8.5	14.0	40	40
	gvz / CP	85	140	650	9.2	16.6	40	40	13.1	16.6	40	40
FBS II 12	gvz / CP	60	110	650	5.3	10.6	50	50	7.5	15.1	50	50
	gvz / CP	75	130	650	7.6	15.2	50	50	10.9	15.2	50	50
	gvz / CP	100	150	650	12.0	20.3	50	50	17.1	20.3	50	50
FBS II 14	gvz / CP	65	120	650	5.8	11.6	60	60	8.3	16.6	60	60
	gvz / CP	85	140	650	9.0	18.0	60	60	12.8	22.1	60	60
	gvz / CP	115	180	650	14.7	29.4	60	60	21.0	29.4	60	60

¹⁾ Design according to EN 1992-4:2018 (for static resp. quasi-static loads). The partial safety factors for material resistance as regulated in the ETA as well as a partial safety factor for load actions of $\gamma_L = 1.4$ are considered. As a single anchor counts e.g. an anchor with a spacing $s \geq 3 \times h_{ef}$ and an edge distance $c \geq 1.5 \times h_{ef}$. Accurate data see ETA.

²⁾ Maximum allowable torque for installation with any tangential impact screw driver. Further technical data see ETA.

³⁾ In the case of combinations of tension and shear loads, bending moments with reduced or minimum spacing and edge distances (anchor groups), the design must be carried out in accordance with the provisions of the complete ETA and the provisions of the EN 1992-4:2018. We recommend using our anchor design software C-FIX.

Loads

Concrete screw UltraCut FBS II US R hexagon head with integral washer and FBS II SK R countersunk head

Permissible loads of a single anchor¹⁾ in normal concrete of strength class C20/25.
For the design the complete current assessment ETA-17/0740 has to be considered.

Type	Material/ surface	Screw-in depth h_{nom} [mm]	Minimum member thickness h_{min} [mm]	Maximum installation torque $T_{imp,max}^{2)}$ [Nm]	Cracked concrete				Non-cracked concrete			
					Permissible tension (N_{perm}) and shear loads (V_{perm}); minimum spacing (s_{min}) and edge distances (c_{min}) with reduced loads				Permissible tension (N_{perm}) and shear loads (V_{perm}); minimum spacing (s_{min}) and edge distances (c_{min}) with reduced loads			
					$N_{perm}^{3)}$ [kN]	$V_{perm}^{3)}$ [kN]	$s_{min}^{3)}$ [mm]	$c_{min}^{3)}$ [mm]	$N_{perm}^{3)}$ [kN]	$V_{perm}^{3)}$ [kN]	$s_{min}^{3)}$ [mm]	$c_{min}^{3)}$ [mm]
FBS II 8	R	50	100	450	1.9	4.1	35	35	3.3	5.9	35	35
FBS II 8	R	65	120	450	4.3	6.1	35	35	6.7	8.8	35	35
FBS II 10	R	55	100	450	2.1	4.6	40	40	4.0	6.6	40	40
FBS II 10	R	65	120	450	2.9	6.0	40	40	6.7	8.5	40	40
FBS II 10	R	85	140	450	7.6	18.4	40	40	13.1	20.9	40	40
FBS II 12	R	60	110	650	2.1	5.3	50	50	4.8	7.5	50	50
FBS II 12	R	75	130	650	5.2	15.2	50	50	5.7	21.8	50	50
FBS II 12	R	100	150	650	12.0	23.9	50	50	17.1	26.2	50	50

¹⁾ Design according to EN 1992-4:2018 (for static resp. quasi-static loads). The partial safety factors for material resistance as regulated in the ETA as well as a partial safety factor for load actions of $\gamma_L = 1.4$ are considered. As a single anchor counts e.g. an anchor with a spacing $s \geq 3 \times h_{ef}$ and an edge distance $c \geq 1.5 \times h_{ef}$. Accurate data see ETA.

²⁾ Maximum allowable torque for installation with any tangential impact screw driver. Further technical data see ETA.

³⁾ In the case of combinations of tension and shear loads, bending moments with reduced or minimum spacing and edge distances (anchor groups), the design must be carried out in accordance with the provisions of the complete ETA and the provisions of the EN 1992-4:2018. We recommend using our anchor design software C-FIX.

Loads

Concrete screw UltraCut FBS II

Recommended loads^{1) 3)} for a single anchor or a fixing point^{4) 5) 6)} in solid brick masonry.

Type		FBS II 8	FBS II 10
Anchorage depth	h_{nom} [mm]	65	85
Recommended loads (F_{rec}) in the respective base material ^{2) 3)}			
Solid clay brick (EN771-1) $\geq 240 \times 113 \times 115$ mm	$f_b \geq 12$ [kN]	1.1 ¹⁰⁾	1.4 ¹⁰⁾
Solid clay brick (EN771-1) $\geq 240 \times 113 \times 115$ mm	$f_b \geq 20$ [kN]	1.6 ^{7) 10)}	1.6 ^{7) 10)}
Solid sand-lime brick (EN771-2) $\geq 240 \times 71 \times 115$ mm	$f_b \geq 12$ [kN]	1.2 ^{7) 10)}	1.2 ^{7) 10)}
Aerated concrete (EN771-4) $\geq 499 \times 249 \times 120$ mm	$f_b \geq 6$ [kN]	0.7	0.9
Minimum spacing (s_{min}) and edge distances (c_{min})			
Minimum spacing within anchor groups of 2 or 4 anchors	s_{min} [mm]	80	80
Minimum spacing between single anchors or anchor groups	s_{min} [mm]	80	80
Minimum distance to the horizontal joint	$c_{min,v}^{8)}$ [mm]	20	20
Minimum distance to the vertical joint	$c_{min,h}^{8)}$ [mm]	40	40
Minimum distance to the free edge	$c_{min,free\ edge}^{8)}$ [mm]	200	200
Tightening torque ⁹⁾ ($T_{tighten}$) in respective base material			
Solid clay brick ¹⁰⁾	$T_{tighten}$ [Nm]	10	10
Solid sandlime brick ¹⁰⁾	$T_{tighten}$ [Nm]	15	15
Aerated concrete	$T_{tighten}$ [Nm]	5	5

¹⁾ An appropriate safety factor is considered.

²⁾ The given loads apply to the given brick measures for masonry with superimposed load. Larger brick formats are at least equivalent in case of the loads. Base material f_b in [N/mm²].

³⁾ The loads only apply to multiple fixings of non-load-bearing systems and are valid for tensile load, shear load and oblique load under any angle.

⁴⁾ To confirm the given technical data, it is recommended to carry out tests on the construction site. In case of not visible joints a 100% testing of the anchors is recommended as the concrete screws only work in the brick but not in mortar joints.

⁵⁾ A fixing point can be a single anchor, 2 anchors or 4 anchors with a minimum spacing s_{min} . Anchor groups of 4 anchors are arranged in rectangular disposition.

⁶⁾ The fixing points have to be arranged in this way that there will be always maximum one fixing point arranged in one brick.

⁷⁾ Brick pull-out is decisive.

⁸⁾ The values $c_{min,v}$ and $c_{min,h}$ are only valid if the mortar joints are filled proper. Otherwise the joints has to be considered as free edges and $c_{min,free\ edge}$ is decisive. Minimum mortar strength is M 2.5.

⁹⁾ The screw is screwed in with a cordless screwdriver, an impact screwdriver or by hand. The screwing process must be finished immediately when the screw head is in contact with the assembled object. The specified tightening torque must then be applied with a torque wrench.

¹⁰⁾ The values are valid for unperforated solid bricks.

Loads

Concrete screw UltraCut FBS II for temporary fastening

Permissible loads of a single anchor¹⁾ in normal concrete of strength class C20/25 to C50/60.
For the design the complete current assessment Z-21.8-2049 has to be considered.

Type	Material/ surface	Screw-in depth h_{nom} [mm]	Minimum member thickness h_{min} [mm]	Maximum installation torque $T_{imp, max}$ ²⁾ [Nm]	Minimum spacing (s_{min}) and edge distances (c_{min})		Cracked and non-cracked concrete			
					s_{min} [mm]	c_{min} ³⁾ [mm]	Permissible load F_{perm} ⁴⁾			
							$f_{c, cube} \geq 10 \text{ N/mm}^2$	$f_{c, cube} \geq 15 \text{ N/mm}^2$	$f_{c, cube} \geq 20 \text{ N/mm}^2$	$f_{c, cube} \geq 25 \text{ N/mm}^2$
							[kN]	[kN]	[kN]	[kN]
FBS II 8	gvz	50	100	400	200	65	1.9	2.3	2.6	2.9
	gvz	65	150	400	300	100	3.6	4.4	5.1	5.6
FBS II 10	gvz	55	105	400	210	70	2.2	2.7	3.1	3.5
	gvz	65	130	400	260	85	2.9	3.5	4.1	4.5
	gvz	85	205	650	410	135	5.8	7.1	8.1	9.1
FBS II 12	gvz	60	120	400	240	80	2.8	3.4	3.9	4.4
	gvz	75	150	400	300	100	4.0	4.9	5.6	6.1
	gvz	100	240	650	480	160	7.6	9.3	10.8	12.0
FBS II 14	gvz	65	115	400	230	75	2.3	2.8	3.2	3.6
	gvz	85	150	400	300	100	3.6	4.4	5.0	5.6
	gvz	115	255	650	510	170	8.9	10.9	12.6	14.0

¹⁾ Material safety factor as well as a partial safety factor for load actions of $\gamma_L = 1.4$ is considered. The screw may be used in the concrete member before the characteristic compressive strength $f_{ck, cube}$ is reached. In this case, the concrete compressive strength $f_{c, cube}$ must have reached a value of at least 10 N/mm^2 . Only intended for temporary use and one-time screwing into the same drill hole. Conditions for reuse of the screw see, approval.

²⁾ Values for impulse wrenches with tangential impact and automatic stop device.

³⁾ In case of combined action of shear load and installation close to the edge, the edge distance must be $\geq c_{min} \times 1.5$. Detail see approval.

⁴⁾ Values valid for all load directions.

Concrete screw UltraCut FBS II 6

The high-performance concrete screw for absolute installation ease

4

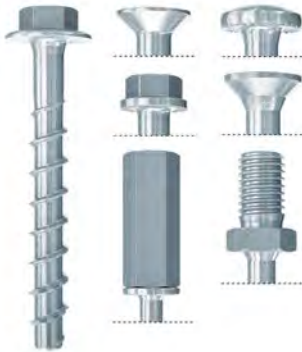

Suspended air-conditioners



Light, suspended pipelines

Applications

- Pipeline routes
- Suspension for individual pipes
- Suspended mounting rails
- Prestressed concrete hollow core ceilings
- Cable trays
- Ventilation ducts
- Perforated tapes
- Air conditioning units

Advantages

- The first concrete screw with diameter 6 with variable embedment depth offers a flexible adaption of the embedment depth to the loads.
- The ETA assessment includes the use in cracked and non-cracked concrete for highest safety requirements.
- The first 6 mm diameter concrete screw with an ETA for the C1 seismic performance category for additional safety

- standards.
- Different head designs offer a maximum of flexibility and a perfect adaptation to the application.
- The UltraCut FBS II 6 is approved for multiple use of non-load bearing systems and thereby ideal for the installation of pipe routes, cable trays and prestressed hollow concrete ceilings.

Certificates



ETA-15/0352, for cracked concrete
ETA-18/0242, for non-structural applications in concrete



Fire resistance classification
R120

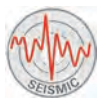

Building materials

Approved for:

- Concrete C20/25 to C50/60, cracked and non-cracked
- Prestressed hollow concrete ceilings C30/37 to C50/60 for the multiple use of non-load bearing systems

Also suitable for:

- Concrete C12/15
- Solid building materials
- Masonry with dense structure

Versions

- Zinc-plated steel

Functioning

- The UltraCut FBS II is recommended for the push-through / pre-positioned installation.
- Drill holes do not need to be cleaned during vertical installation (ceiling and floor). For floor fixings the hole must be drilled 3x drill hole diameter deeper.
- The approved adjustment for the concrete screws allows the screw to be unscrewed twice for a total length of 20 mm, to place maximum 10 mm packing below the base plates or to align the attached part, and then to tighten the screw again.
- We recommend using a fischer impact wrench FSS 18V with a suitable impact screwdriver socket or an internal torx drive.
- The screw is installed correctly when the screw head sits flush on the fixture (visual setting control).

Installation UltraCut FBS II 6

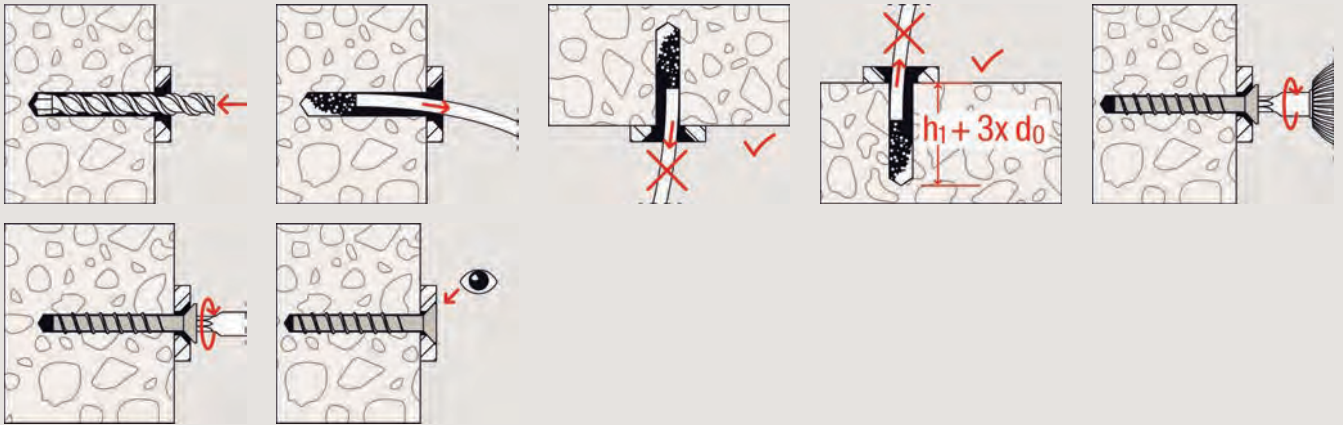

4

Fixture adjustment

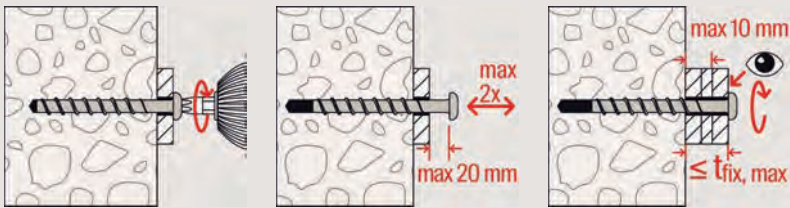

Additional for seismic applications

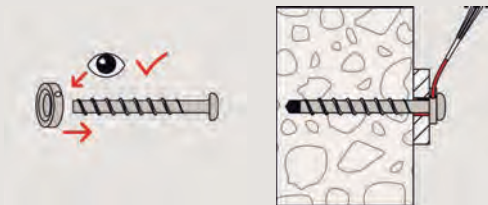

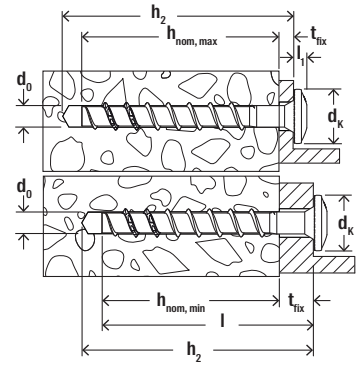

Technical data

Concrete screw UltraCut FBS II 6

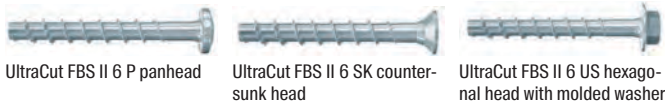

Item	Item No.	Approval ETA	Drill hole diameter	Min. drill hole depth for through fixings	Screw length	Head-Ø	Screw-in depth Multiple fixing ETA-18/0242	Screw-in depth Single point fixing ETA-15/0352	Usable length	Drive	Sales unit
			d_0 [mm]	h_2 [mm]	l_s [mm]	d_K [mm]	$h_{nom,min} - h_{nom,max}$ [mm]	$h_{nom,min} - h_{nom,max}$ [mm]	$t_{fix,min} - t_{fix,max}$ [mm]		[pcs]
FBS II 6 x 30/5 P	546377	●	6	40	30	14.4	25	—	Screw length - h_{nom}	T30	100
FBS II 6 x 40/5 P	546378	●	6	50	40	14.4	25 - 35	—	Screw length - h_{nom}	T30	100
FBS II 6 x 40/5 LP	546379	●	6	50	40	17.5	25 - 35	—	Screw length - h_{nom}	T30	100
FBS II 6 x 60/5 P	546380	●	6	70	60	14.4	25 - 55	40 - 55	Screw length - h_{nom}	T30	100
FBS II 6 x 80/25 P	546381	●	6	90	80	14.4	25 - 55	40 - 55	Screw length - h_{nom}	T30	100
FBS II 6 x 30/5 SK	546382	●	6	40	30	13.5	25	—	Screw length - h_{nom}	T30	100
FBS II 6 x 40/5 SK	546383	●	6	50	40	13.5	25 - 35	—	Screw length - h_{nom}	T30	100
FBS II 6 x 60/5 SK	546384	●	6	70	60	13.5	25 - 55	40 - 55	Screw length - h_{nom}	T30	100
FBS II 6 x 80/25 SK	546385	●	6	90	80	13.5	25 - 55	40 - 55	Screw length - h_{nom}	T30	100
FBS II 6 x 100/45 SK	546386	●	6	110	100	13.5	25 - 55	40 - 55	Screw length - h_{nom}	T30	100
FBS II 6 x 120/65 SK	546387	●	6	130	120	13.5	25 - 55	40 - 55	Screw length - h_{nom}	T30	100
FBS II 6 x 140/85 SK	546388	●	6	150	140	13.5	25 - 55	40 - 55	Screw length - h_{nom}	T30	100
FBS II 6 x 160/105 SK	546389	●	6	170	160	13.5	25 - 55	40 - 55	Screw length - h_{nom}	T30	100
FBS II 6 x 40/5 US	546390	●	6	50	40	17	25 - 35	—	Screw length - h_{nom}	SW 10	100
FBS II 6 x 60/5 US	546391	●	6	70	60	17	25 - 55	40 - 55	Screw length - h_{nom}	SW 10	100
FBS II 6 x 80/25 US	546392	●	6	90	80	17	25 - 55	40 - 55	Screw length - h_{nom}	SW 10	100
FBS II 6 x 100/45 US	546393	●	6	110	100	17	25 - 55	40 - 55	Screw length - h_{nom}	SW 10	100
FBS II 6 x 120/65 US	546394	●	6	130	120	17	25 - 55	40 - 55	Screw length - h_{nom}	SW 10	100

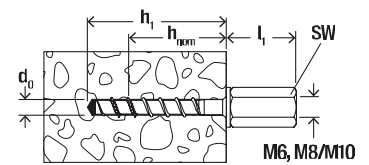
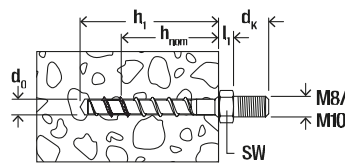

Technical data

Concrete screw UltraCut FBS II 6 M8/M10



UltraCut FBS II M8/M10
outside thread



UltraCut FBS II M6, M8/M10 I
internal thread

Item	Item No.	Approval ETA	Drill hole diameter	Min. drill hole depth for pre-positioned installation	Screw diameter	Screw length	Screw-in depth Multiple fixing ETA-18/0242	Screw-in depth Single point fixing ETA-15/0352	Drive	Sales unit [pcs]
			d_0 [mm]	h_1 [mm]	d_s [mm]	l_s [mm]	$h_{nom,min} - h_{nom,max}$ [mm]	$h_{nom,min} - h_{nom,max}$ [mm]		
FBS II 6 x 25 M8/19	546395	●	6	30	7,5	25	25	—	SW 10	100
FBS II 6 x 35 M8/19	546396	●	6	40	7,5	35	35	—	SW 10	100
FBS II 6 x 55 M8/19	546397	●	6	60	7,5	55	55	55	SW 10	100
FBS II 6 x 35 M10/21	546398	●	6	40	7,5	35	35	—	SW 13	100
FBS II 6 x 55 M10/21	546399	●	6	60	7,5	55	55	55	SW 13	100
FBS II 6 x 35 M6 I	554065	●	6	40	7,5	35	35	—	SW 13	100
FBS II 6 x 55 M6 I	554066	●	6	60	7,5	55	55	55	SW 13	100
FBS II 6 x 35 M8/M10 I	546400	●	6	40	7,5	35	35	—	SW 13	100
FBS II 6 x 55 M8/M10 I	546401	●	6	60	7,5	55	55	55	SW 13	100

Loads

Concrete screw UltraCut FBS II 6

Permissible loads of a single anchor¹⁾ in normal concrete of strength class C20/25.
For the design the complete current assessment ETA-15/0352 has to be considered.

Type	Material/ surface	Screw-in depth h_{nom} [mm]	Minimum member thickness h_{min} [mm]	Maximum installation torque $T_{imp,max}^{2)}$ [Nm]	Cracked concrete				Non-cracked concrete			
					Permissible tension (N_{perm}) and shear loads (V_{perm}); minimum spacing (s_{min}) and edge distances (c_{min}) with reduced loads				Permissible tension (N_{perm}) and shear loads (V_{perm}); minimum spacing (s_{min}) and edge distances (c_{min}) with reduced loads			
					$N_{perm}^{3)}$ [kN]	$V_{perm}^{3)}$ [kN]	$s_{min}^{3)}$ [mm]	$c_{min}^{3)}$ [mm]	$N_{perm}^{3)}$ [kN]	$V_{perm}^{3)}$ [kN]	$s_{min}^{3)}$ [mm]	$c_{min}^{3)}$ [mm]
FBS II 6	gvz	40	80	450	1.2	4.3	35	35	3.8	4.3	35	35
	gvz	45	90	450	1.7	4.3	35	35	4.8	4.3	35	35
	gvz	50	90	450	1.9	4.3	35	35	5.7	4.3	35	35
	gvz	55	100	450	2.4	6.3	35	35	6.4	6.3	35	35

¹⁾ Design according to EN 1992-4:2018 (for static resp. quasi-static loads). The partial safety factors for material resistance as regulated in the ETA as well as a partial safety factor for load actions of $\gamma_L = 1.4$ are considered. As a single anchor counts e.g. an anchor with a spacing $s \geq 3 \times h_{ef}$ and an edge distance $c \geq 1.5 \times h_{ef}$. Accurate data see ETA.

²⁾ Maximum allowable torque for installation with any tangential impact screw driver. Further technical data see ETA.

³⁾ In the case of combinations of tension and shear loads, bending moments with reduced or minimum spacing and edge distances (anchor groups), the design must be carried out in accordance with the provisions of the complete ETA and the provisions of the EN 1992-4:2018. We recommend using our anchor design software C-FIX.

Loads

Concrete screw UltraCut FBS II 6

Permissible loads for a single anchor¹⁾ for multiple use of redundant non-structural applications* in normal concrete C20/25.
For the design the complete current assessment ETA - 18/0242 has to be considered.

Type	Material/ surface	Screw-in depth h_{nom} [mm]	Minimum member thickness h_{min} [mm]	Maximum installation torque $T_{inst,max}^{2)}$ [Nm]	Cracked concrete				Non-cracked concrete			
					Permissible tension (N_{perm}) and shear loads (V_{perm}); minimum spacing (s_{min}) and edge distances (c_{min}) with reduced loads				Permissible tension (N_{perm}) and shear loads (V_{perm}); minimum spacing (s_{min}) and edge distances (c_{min}) with reduced loads			
					$N_{perm}^{3)}$ [kN]	$V_{perm}^{3)}$ [kN]	$s_{min}^{3)}$ [mm]	$c_{min}^{3)}$ [mm]	$N_{perm}^{3)}$ [kN]	$V_{perm}^{3)}$ [kN]	$s_{min}^{3)}$ [mm]	$c_{min}^{3)}$ [mm]
FBS II 6	gvz	25	80	≤ 5	0.7	1.8	35	35	1.4	2.3	35	35
	gvz	30	80	≤ 5	1.2	2.3	35	35	2.4	2.3	35	35
	gvz	35	80	≤ 5	1.7	4.3	35	35	3.1	4.3	35	35
	gvz	40	80	≤ 10	2.4	4.3	35	35	3.8	4.3	35	35
	gvz	45	90	≤ 10	2.9	4.3	35	35	4.8	4.3	35	35
	gvz	50	90	≤ 10	3.6	4.3	35	35	5.7	4.3	35	35
	gvz	55	100	≤ 10	4.0	6.3	35	35	6.4	6.3	35	35

* In addition to the load table above, the following must be considered for multiple fastening of non-structural redundant systems:

A multiple fixing (redundant system) according to EN 1992-4 and CEN/TR 17079 is defined by

- at least 3 fixing points (per attached element) with at least one anchor at each fixing point and a permissible load per fixing point of 1.4 kN

- or by at least 4 fixing points with at least one anchor each fixing point and a permissible load per fixing point of 2.1 kN

- Additionally, it has to be proven that the stiffness of the attached element shall be large enough to ensure that in case of excessive slip or failure of a fastener the load on this fastener or fixing point can be transferred to neighbouring fixing points without significantly violating the requirements on the attached element in the serviceability and ultimate limit state.

For further details see EN 1992-4 section 7.3 and CEN/TR 17079.

¹⁾ Design according to EN 1992-4:2018 (for static resp. quasi-static loads). The partial safety factors for material resistance as regulated in the ETA as well as a partial safety factor for load actions of $\gamma_L = 1.4$ are considered.

²⁾ Further technical information for installation see ETA.

³⁾ In the case of combinations of tension and shear loads, bending moments with reduced or minimal edge and axial spacings (anchor groups), the design must be carried out in accordance with the provisions of the complete ETA and the provisions of the EN 1992-4:2018.

Loads

Concrete screw UltraCut FBS II 6

Permissible loads for a single anchor¹⁾ for multiple use of redundant non-structural applications* in pre-stressed hollow-core concrete slabs of concrete strength C30/37.
For the design the complete current assessment ETA - 18/0242 has to be considered.

Type	FBS II 6 gvz								
Screw-in depth	h_{nom}	25	30	35	40	45	50	55	
Permissible load $F_{perm}^{3)}$ in the respective bottom flange thickness									
$d_b \geq 25$ mm	[kN]	0.2	0.5	0.5	0.5	0.5	0.5	0.5	0.5
$d_b \geq 30$ mm	[kN]	1.7	1.7	1.7	1.7	1.7	1.7	1.7	1.7
$d_b \geq 35$ mm	[kN]	1.7	1.9	2.1	2.4	2.6	2.9	3.1	3.1
$d_b \geq 40$ mm	[kN]	1.7	2.3	2.6	2.9	3.3	3.6	3.8	3.8
$d_b \geq 50$ mm	[kN]	1.7	2.3	3.3	3.8	4.3	4.3	5.7	5.7
Installation torque	$T_{inst,max}$ [Nm]	5.0	5.0	10	10	10	10	10	10
Minimum spacing	$s_{1,s2}^{2)}$ [mm]	100	100	100	100	100	100	100	100
Minimum edge distance	$c_{1,c2}^{2)}$ [mm]	100	100	100	100	100	100	100	100

* In addition to the load table above, the following must be considered for multiple fastening of non-structural redundant systems:

A multiple fixing (redundant system) according to EN 1992-4 and CEN/TR 17079 is defined by

- at least 3 fixing points (per attached element) with at least one anchor at each fixing point and a permissible load per fixing point of 1.4 kN

- or by at least 4 fixing points with at least one anchor each fixing point and a permissible load per fixing point of 2.1 kN

- Additionally, it has to be proven that the stiffness of the attached element shall be large enough to ensure that in case of excessive slip or failure of a fastener the load on this fastener or fixing point can be transferred to neighbouring fixing points without significantly violating the requirements on the attached element in the serviceability and ultimate limit state.

For further details see EN 1992-4 section 7.3 and CEN/TR 17079.

¹⁾ Design according to EN 1992-4:2018 (for static resp. quasi-static loads). The partial safety factors for material resistance as regulated in the ETA as well as a partial safety factor for load actions of $\gamma_L = 1.4$ are considered.

²⁾ Further technical information for installation see ETA.

³⁾ Valid for tensile load, shear load and oblique load under any angle. In the case of combinations of tensile, shear loads and bending moments, the design must be carried out in accordance with the provisions of the complete ETA and the provisions of the EN 1992-4:2018.

Concrete screw FBS N

The powerful inch concrete screw for a fast and simple installation



High-bay warehouses



Steel girders

4

Applications

- Guard rails
- Consoles/Base plates
- Metal profiles
- Shelving systems
- Beam anchorage steel

Advantages

- The special thread geometry enables fast cutting into the concrete and allow higher loads.
- The expansion-free anchorage (undercut) ensures low edge and axial clearances.
- The ribs under the head prevent acciden-

tal loosening of the concrete screw and making the system more secure.

- The hexagonal head for a visually aesthetic installation.

Building materials

- Concrete from 2.500psi until 8.000psi, non-cracked

Version

- Zinc-plated steel

Functioning

- The concrete screw FBS-N US is suitable for push-through installation.
- For the installation, we recommend the fischer impact wrench FSS 18V with a compatible socket.
- If the screw head is in contact with the fixture, the correct installation of the screw is ensured (visual setting check).

Installation FBS-N

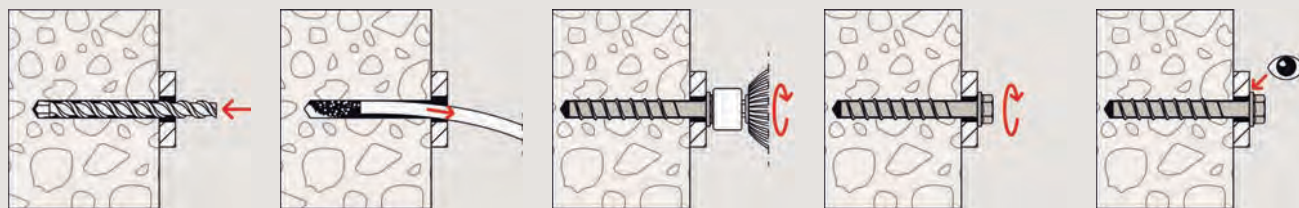

Technical data

4

Concrete screw FBS N



FBS N US

FBS N I

Item	Item No.	Drill diameter d_0 [inch]	Min. drill hole depth for pre-positioned installation h_1 [inch]	Min. drill hole depth for through fixings h_2 [inch]	Anchor length l [inch]	Screw-in depth h_{nom} [inch]	Max. usable length t_{fix} [inch]	Clearance hole diameter d_f [inch]	Through hole [inch]	Connection thread UNC [inch]	Sales unit [pcs]
FBS N 1/4x1-5/8 3/8	548800	1/4	2 1/8	—	1 5/8	1 5/8	—	3/8	3/8	3/8	100
FBS N 1/4x2-1/2 3/8	548802	1/4	2 5/8	—	2 1/2	2 1/2	—	3/8	3/8	3/8	100
FBS N 1/4x1-5/8 1/4	548803	1/4	2 1/8	—	1 5/8	1 5/8	—	3/8	3/8	1/4	100
FBS N 1/4x2-1/2 1/4	548804	1/4	2 5/8	—	2 1/2	2 1/2	—	3/8	3/8	1/4	100
FBS N 3/8x2-1/8 US	548805	3/8	—	2 1/4	2 1/8	1 5/8	1/2	1/2	1/2	—	50
FBS N 3/8x3 US	548806	3/8	—	3	3	2 1/2	1/2	1/2	1/2	—	50
FBS N 1/2x4 US	548807	1/2	—	3 1/2	4	3	1	5/8	5/8	—	25
FBS N 1/2x6 US	548808	1/2	—	4 3/4	6	4 1/4	1 3/4	5/8	5/8	—	25
FBS N 5/8x4 US	548809	5/8	—	3 3/4	4	3 1/4	3/4	3/4	3/4	—	15
FBS N 3/4x5-1/2 US	548810	3/4	—	4 1/2	5 1/2	4	1 1/2	7/8	7/8	—	10

Loads

Concrete screw FBS N											
Recommended loads of a single anchor ^{1) 2)} in non-cracked concrete.											
Type			FBS N								
			1/4 x 1-5/8	1/4 x 2-1/2	3/8 x 2-1/8	3/8 x 3	1/2 x 4	1/2 x 6	5/8 x 4	3/4 x 5-1/2	3/4 x 7
Screw-in depth	h_{nom}	[mm]	41	64	41	64	76	108	83	102	159
Recommended tensile loads in non-cracked normal weight concrete strength ^{1) 2)}											
2500 psi (17.3 Mpa)		[kN]	1.4	3.5	2.6	5.3	4.8	7.2	5.6	7.2	16.7
3000 psi (20.7 Mpa)		[kN]	1.5	3.8	2.9	5.8	5.3	7.7	6.1	8.0	18.3
4000 psi (27.6 Mpa)		[kN]	1.6	4.4	3.2	6.6	5.9	8.5	6.9	9.2	20.9
6000 psi (41.4 Mpa)		[kN]	1.9	5.4	3.7	7.6	6.9	10.1	8.5	11.2	25.7
8000psi (55.2 Mpa)		[kN]	2.0	6.1	4.5	9.0	8.4	11.6	10.1	13.5	30.5
Recommended shear loads in non-cracked normal weight concrete strength ^{1) 2)}											
2500 - 8000 psi (17.3 - 55.2 Mpa)		[kN]	2.6	2.6	7.7	7.7	17.0	17.0	30.9	38.6	38.6
Installation data											
Nominal drill diameter	d_0	[mm]	6.4	6.4	9.5	9.5	12.7	12.7	15.9	19.1	19.1
Min. drill depth at push-through mode	h_2	[mm]	54 ³⁾	76 ³⁾	57	76	89	121	95	114	171
Nominal screwing depth	$h_{nom1} \geq$	[mm]	41	64	41	64	76	108	83	102	159
Anchor length	l	[mm]	41	64	54	76	102	152	102	140	178
Max. fixing thickness	$t_{fix1} \leq$	[mm]	-	-	13	13	25	44	19	38	19
Clearance hole diameter	d_f	[mm]	-	-	13	13	16	16	19	22	22
Width across flats	SW	[mm]	12.7	12.7	14.3	14.3	19.1	19.1	23.8	26.8	26.8
Torque impact screw driver	T_{impact}	[mm]	170	170	200	200	460	460	460	520	520
Min. member thickness	h_{min}	[mm]	83	89	110	125	138	171	146	168	237
Min. edge distance	c_{min}	[mm]	38	38	45	45	45	45	45	45	45
Min. spacing	s_{min}	[mm]	38	38	76	76	76	76	76	76	76

¹⁾ Safety Factor of 4 is considered.

²⁾ Concrete compressive strength must be at the specified minimum at the time of installation. In the case of combinations of tensile and shear loads, bending moments and reduced edge and axial spacing (anchor groups), the design must be carried out in accordance to the provisions of the valid standard.

³⁾ Minimum drill hole depth h_0 at pre-positioned installation.

Hammer-set anchor EA II

The internally threaded anchor with rim for simple hammer-set installation

4



Pipelines

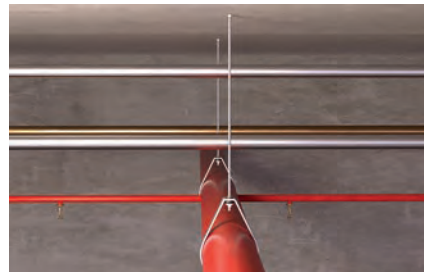

Sprinklers

Applications

- Pipelines and ventilation ducts
- Sprinkler systems
- Cable conduits and wires
- Gratings
- Steel constructions
- Machines
- Consoles
- Shuttering props
- Diamond or core drilling devices (EA II M12 D)

Advantages

- The embossed rim prevents the anchor sleeve from slipping, thus ensuring a trouble-free hammer-set installation.
- The metric internal thread means that it is possible to use standard screws or threaded rods for the ideal adaptation to suit the intended use.
- The EMS machine setting tool allows for effortless installation, particularly in the case of series installations.
- The embossing that is applied when

- expanding with the EHS Plus setting tool offers a simple control of the anchoring and provides increased safety.
- Fixing point at h_{ef} 25 mm prevents anchor of falling out of the drill hole before being expanded.
- The black fixing point prevents the anchor from falling out of the drill hole during overhead installation.

Certificates



ETA-07/0135, for non-cracked concrete
ETA-07/0142, for non-structural applications in concrete



Fire resistance classification R120



from M10



INOX STAINLESS STEEL



from M8

Building materials

Approved for:

- Concrete C20/25 to C50/60, cracked, for the multiple fixings of non-load-bearing systems
- Concrete C20/25 to C50/60, non-cracked

Also suitable for:

- Concrete C12/15
- Natural stone with dense structure

Versions

- Zinc-plated steel
- Stainless steel R

Functioning

- The EA II is suitable for pre-positioned installation.
- Position the hammer-set anchor in the drill hole and drive in flush to the surface of the anchor base using the hammer.
- The sleeve is then expanded by driving in the internal bolt with the EHS Plus setting tool (alternative: EMS machine setting tool), and expanded against the drill hole wall.
- The setting tools must sit on the rim of the anchor to ensure correct expansion.
- Use the special EA II M12 x 50 D / EA M 12 x 50 N D with thicker sleeve for fixing diamond and core drilling devices.

Installation EA II

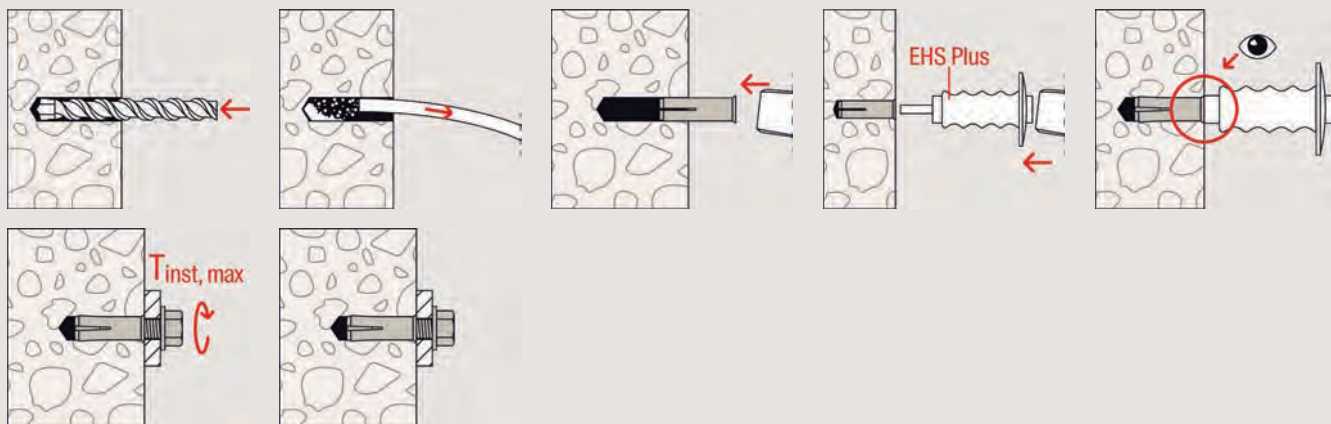

4

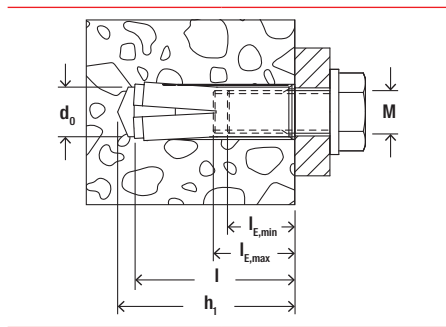

Technical data

Hammerset anchor EA II



EA II with reduced anchorage depth h_{ef} of 25 mm and a black fixing point which prevents the anchor from falling out of the drill hole



EA II not suitable for diamond drilling appliances and diamond saws

	Zinc-plated steel	Stainless steel	Approval	Drill hole diameter	Min. drill hole depth for pre-positioned installation	Anchor length	Internal thread	Min. bolt penetration	Max. bolt penetration	Sales unit
Item	Item No. gvz	Item No. R	ETA	d_0 [mm]	h_1 [mm]	l [mm]	M	$l_{E,min}$ [mm]	$l_{E,max}$ [mm]	[pcs]
EA II M 6 x 25	532230	—	●	8	27	25	M 6	6	14	100
EA II M 6 x 30	048264	048410	●	8	32	30	M 6	6	14	100
EA II M 8 x 25	532231	—	●	10	27	25	M 8	8	14	100
EA II M 8 x 30	048284	048411	●	10	33	30	M 8	8	14	100
EA II M 8 x 40	048323	048412	●	10	43	40	M 8	8	14	50
EA II M 10 x 25	532232	—	●	12	27	25	M 10	10	14	50
EA II M 10 x 30	048332	—	●	12	33	30	M 10	10	14	50
EA II M 10 x 40	048339	048414	●	12	43	40	M 10	10	17	50
EA II M 12 x 25	532233	—	●	15	27	25	M 12	12	14	25
EA II M 12 x 50	048406	048415	●	15	54	50	M 12	12	22	25
EA II M 16 x 65	048408	048416	●	20	70	65	M 16	16	28	20
EA II M 20 x 80	048409	048417	●	25	85	80	M 20	20	34	10

Technical data

Hammer set anchor EA II D



EA II M 12 x 50 D suitable for diamond drilling appliances and diamond saws

Hammer set anchor EA M 12 x 50 N D. Suitable for diamond drilling machines and diamond saws.

	Zinc-plated steel	Approval	Drill hole diameter d_0 [mm]	Min. drill hole depth h_1 [mm]	Anchor length l [mm]	Internal thread M	Min. bolt penetration $l_{E,min}$ [mm]	Max. bolt penetration $l_{E,max}$ [mm]	Sales unit [pcs]
Item	Item No.	ETA							
EA M 12 x 50 N D	500872	—	16	54	50	M 12	12	22	50
EA II M 12 x 50 D	048407	●	16	54	50	M 12	12	22	25

4

Technical data

Stop drill EBB



EBB

	Item No.	Tool holder	Drill hole diameter d_0 [mm]	Drill hole depth h_0 [mm]	Match	Sales unit [pcs]
Item						
EBB 8 x 25	532607	SDS plus	8	27	EA II M 6 x 25	1
EBB 10 x 25	532608	SDS plus	10	27	EA II M 8 x 25	1
EBB 12 x 25	532609	SDS plus	12	27	EA II M 10 x 25	1
EBB 15 x 25	532610	SDS plus	15	27	EA II M 12 x 25	1

Technical data

Machine setting tool EMS



EMS

	Item No.	Tool holder	Match	Sales unit [pcs]
Item				
EMS M 6 x 25/30	048065	SDS plus	EA II M 6 x 25, EA II M 6 x 30	1
EMS M 8 x 25/30	048066	SDS plus	EA II M 8 x 25, EA II M 8 x 30	1
EMS M 8 x 40	048067	SDS plus	EA II M 8 x 40	1
EMS M 10 x 25/30	048068	SDS plus	EA II M 10 x 25, EA II M 10 x 30	1
EMS M 10 x 40	048070	SDS plus	EA II M 10 x 40	1
EMS M 12 x 50	048071	SDS plus	EA II M 12 x 50 D, EA II M 12 x 50, EA M 12 x 50 N D	1
EMS M 16 x 65	048072 ¹⁾	SDS max	EA II M 16 x 65	1
EMS M 20 x 80	048073 ¹⁾	SDS max	EA II M 20 x 80	1

¹⁾ Delivery time on request.

Technical data

Setting tool EMS Plus



EHS Plus with hand impact protection for your safety and embossing tool

EA-ST

Item	Item No.	Match	Sales unit [pcs]
EHS M 6 x 25/30 Plus	044630	EA II M 6 x 25, EA II M 6 x 30	1
EHS M 8 x 25/30 Plus	044631	EA II M 8 x 25, EA II M 8 x 30	1
EHS M 8 x 40 Plus	044632	EA II M 8 x 40	1
EHS M 10 x 25/30 Plus	048487	EA II M 10 x 25, EA II M 10 x 30	1
EHS M 12 x 25 Plus	532568	EA II M 12 x 25	1
EHS M 10 x 40 Plus	044633	EA II M 10 x 40	1
EHS M 12 x 50 Plus	044634	EA II M 12 x 50, EA II M 12 x 50 D	1
EHS M 16 x 65 Plus	044635	EA II M 16 x 65	1
EHS M 20 x 80 Plus	044636	EA II M 20 x 80	1
EA-ST 12	504585	EA M 12 x 50 N D	1

4

Loads

Hammerset anchor EA II

Permissible loads of a single anchor¹⁾ in normal concrete of strength class C20/25. For the design the complete current assessment ETA-07/0135 has to be considered.

Type	Material/surface ²⁾	Screw material	Effective anchorage depth h_{ef} [mm]	Member thickness h_{req} [mm]	Maximum installation torque $T_{inst,max}$ [Nm]	Non-cracked concrete			
						Permissible tension (N_{perm}) and shear loads (V_{perm}); minimum spacing (s_{min}) and edge distances (c_{min}) with reduced loads			
						$N_{perm}^{3)}$ [kN]	$V_{perm}^{3)}$ [kN]	$s_{min}^{3)}$ [mm]	$c_{min}^{3)}$ [mm]
EA II M8 x 40	gvz	5.8	40	100	8	5.9	4.9	70	115
	gvz	8.8	40	100	8	5.9	4.9	70	115
	R	A4-70	40	100	8	5.9	5.6	70	115
EA II M10 x 40	gvz	5.8	40	120	15	5.9	6.2	95	150
	gvz	8.8	40	120	15	5.9	6.2	95	150
	R	A4-70	40	120	15	5.9	7.1	95	150
EA II M12 x 50	gvz	5.8	50	120	35	8.3	11.3	145	200
	gvz	8.8	50	120	35	8.3	11.3	145	200
	R	A4-70	50	120	35	8.3	12.9	145	200
EA II M16 x 65	gvz	5.8	65	160	60	12.3	18.3	180	240
	gvz	8.8	65	160	60	12.3	18.3	180	240
	R	A4-70	65	160	60	12.3	21.1	180	240
EA II M20 x 80	gvz	5.8	80	200	120	16.8	29.1	190	280
	gvz	8.8	80	200	120	16.8	29.1	190	280
	R	A4-70	80	200	120	16.8	33.5	190	280

¹⁾ Design according to EN 1992-4:2018 (for static resp. quasi-static loads). The partial safety factors for material resistance as regulated in the ETA as well as a partial safety factor for load actions of $\gamma_L = 1.4$ are considered. As a single anchor counts e.g. an anchor with a spacing $s \geq 3 \times h_{ef}$ and an edge distance $c \geq 1.5 \times h_{ef}$. Accurate data see ETA.

²⁾ For technical data on steel grade and variants, see ETA.

³⁾ In the case of combinations of tension and shear loads, bending moments with reduced or minimum spacing and edge distances (anchor groups), the design must be carried out in accordance with the provisions of the complete ETA and the provisions of the EN 1992-4:2018. We recommend using our anchor design software C-FIX.

Loads

Hammerset anchor EA II

Permissible loads for a single anchor¹⁾ for multiple use of redundant non-structural applications* in normal concrete C20/25 up to C50/60. For the design the complete current assessment ETA-07/0142 has to be considered.

Type	Material/surface ²⁾	Screw material	Effective anchorage depth h_{ef} [mm]	Minimum member thickness $h_{min}^{3)}$ [mm]	Maximum installation torque $T_{inst,max}$ [Nm]	Cracked and non-cracked concrete		
						Permissible load ($F_{perm}^{4)}$; minimum spacing (s_{min}) and edge distances (c_{min}) with reduced loads	F_{perm} [kN]	s_{min} [mm]
EA II M6 x 25	gvz	4.6	25	80	4	1.0	30	60
EA II M6 x 30	gvz	4.6	30	80	4	1.2	70	150
EA II M8 x 25	gvz	4.6	25	80	8	1.4	70	100
EA II M8 x 30	gvz	4.6	30	80	8	2.0	110	150
EA II M8 x 40	gvz	4.6	40	80	8	2.0	200	150
EA II M10 x 25	gvz	4.6	25	80	15	1.9	80	120
EA II M10 x 30	gvz	4.6	30	80	15	2.0	200	150
EA II M10 x 40	gvz	4.6	40	80	15	3.0	200	150
EA II M12 x 25	gvz	4.6	25	80	35	1.9	100	130
EA II M12 x 50	gvz	4.6	50	100	35	4.3	200	200

* In addition to the load table above, the following must be considered for multiple fastening of non-structural redundant systems:

A multiple fixing (redundant system) according to EN 1992-4 and CEN/TR 17079 is defined by

- at least 3 fixing points (per attached element) with at least one anchor at each fixing point and a permissible load per fixing point of 1.4 kN
- or by at least 4 fixing points with at least one anchor each fixing point and a permissible load per fixing point of 2.1 kN

- Additionally, it has to be proven that the stiffness of the attached element shall be large enough to ensure that in case of excessive slip or failure of a fastener the load on this fastener or fixing point can be transferred to neighbouring fixing points without significantly violating the requirements on the attached element in the serviceability and ultimate limit state.

For further details see EN 1992-4 section 7.3 and CEN/TR 17079.

¹⁾ Design according to EN 1992-4:2018 (for static resp. quasi-static loads). The partial safety factors for material resistance as regulated in the ETA as well as a partial safety factor for load actions of $\gamma_L = 1.4$ are considered.

²⁾ For details of steel grade, variants and further concrete classes, see ETA.

³⁾ Minimum possible member thickness while increasing the spacing and edge distances at the same time. The combination of minimum spacing and edge distances with the minimum member thickness is not possible. Exact data see ETA.

⁴⁾ Valid for tensile load, shear load and oblique load under any angle. In the case of combinations of tensile, shear loads and bending moments, the design must be carried out in accordance with the provisions of the complete ETA and the provisions of the EN 1992-4:2018.

Loads

Hammerset anchor EA II

Permissible loads for a single anchor¹⁾ for multiple use of redundant non-structural applications* in pre-stressed hollow core slabs of concrete C30/37 up to C50/60. For the design the complete current assessment ETA-07/0142 has to be considered.

Type	Material/surface ²⁾	Screw material	Effective anchorage depth h_{ef} [mm]	Bottom flange thickness ⁴⁾ d_b [mm]	Maximum installation torque $T_{inst,max}$ [Nm]	Cracked and non-cracked concrete		
						Permissible load ($F_{perm}^{3)}$; minimum spacing (s_{min}) and edge distances (c_{min}) with reduced loads	F_{perm} [kN]	s_{min} [mm]
EA II M6 x 25	gvz	4.6	25	≥ 35	4	1.0	200	150
EA II M8 x 25	gvz	4.6	25	≥ 35	8	1.4	200	150
EA II M10 x 25	gvz	4.6	25	≥ 35	15	1.9	200	150
EA II M12 x 25	gvz	4.6	25	≥ 35	35	1.9	200	150

* In addition to the load table above, the following must be considered for multiple fastening of non-structural redundant systems:

A multiple fixing (redundant system) according to EN 1992-4 and CEN/TR 17079 is defined by

- at least 3 fixing points (per attached element) with at least one anchor at each fixing point and a permissible load per fixing point of 1.4 kN
- or by at least 4 fixing points with at least one anchor each fixing point and a permissible load per fixing point of 2.1 kN

- Additionally, it has to be proven that the stiffness of the attached element shall be large enough to ensure that in case of excessive slip or failure of a fastener the load on this fastener or fixing point can be transferred to neighbouring fixing points without significantly violating the requirements on the attached element in the serviceability and ultimate limit state.

For further details see EN 1992-4 section 7.3 and CEN/TR 17079.

¹⁾ Design according to EN 1992-4:2018 (for static resp. quasi-static loads). The partial safety factors for material resistance as regulated in the ETA as well as a partial safety factor for load actions of $\gamma_L = 1.4$ are considered.

²⁾ For details of steel grade and variants, see ETA.

³⁾ Valid for tensile load, shear load and oblique load under any angle. In the case of combinations of tensile, shear loads and bending moments, the design must be carried out in accordance with the provisions of the complete ETA and the provisions of the EN 1992-4:2018.

⁴⁾ The anchor may be used in a flange thickness $d_b = 30$ mm with the same characteristic resistance, but the drill hole must not cut a cavity.

Hammerset anchor EA Plus

The cost-efficient and certified hammerset anchor for simple installation

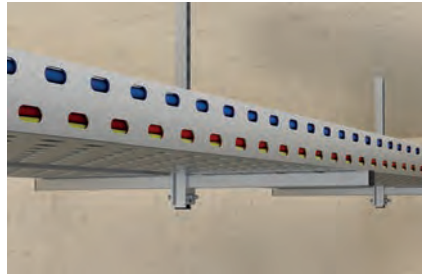

Cable duct

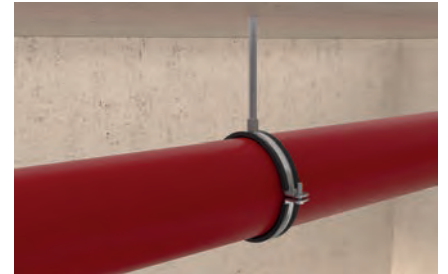

Light pipeline routes

Applications

- Light pipeline routes
- Cable ducts
- Pipeline routes

Advantages

- The ETA-certified hammerset anchor EA Plus offers a high degree of safety in the non-cracked concrete.
- The EA-ST Plus setting tool guarantees a simple and quick installation.
- The hammerset anchor with internal thread enables an easy pre-positioned installation.
- The metric thread of the EA Plus allows

- the usage of all standard screws and therefore offers high flexibility.
- The large range of internal thread diameters of 6 to 12 mm offers a wide range of different applications.
- The EA Plus has an ETA assessment for multiple fixing. This ensures a safe installation of pipe routes or cable trays.

Certificates



ETA 19/0168, for non-cracked concrete



Fire resistance classification R120

ETA 19/0169, for redundant non-structural systems in concrete

Building materials

- Concrete C20/25 to C50/60, non-cracked

Version

- Zinc-plated steel

Funktionsweise

- Position the hammerset anchor in the drill hole and drive in the anchor flush to the surface of the base material by using the hammer.
- The fischer setting tool EA-ST Plus is then used to expand the sleeve against the drill hole wall by driving in the internal pin.
- The setting tool must sit on the edge of the anchor to ensure correct expansion.

Installation EA Plus

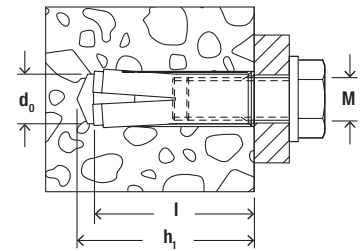
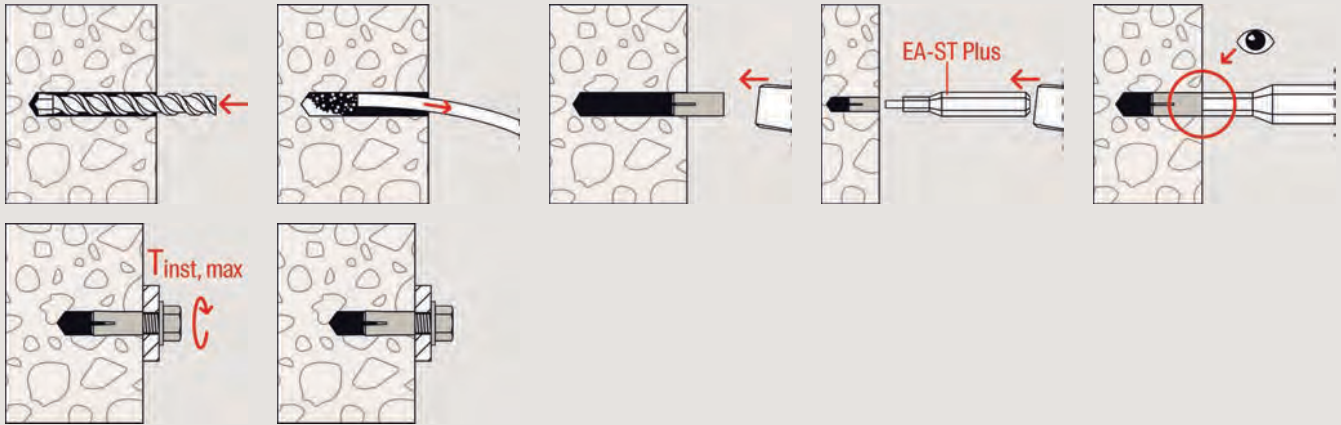

Technical data

Hammerset anchor EA Plus

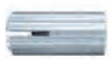

EA Plus M 6 + M 8



EA Plus M 10 + M 12

Item	Item No. gvz	Approval ETA	Drill hole diameter d_0 [mm]	Min. drill hole depth for through fixings h_2 [mm]	Anchor length l [mm]	Required torque [Nm]	Thread M	Required setting tool	Sales unit [pcs]
EA Plus M 6 x 25	551788	●	8	25	25	4	M 6	EA-ST-Plus M 6 x 25	100
EA Plus M 8 x 30	551789	●	10	30	30	8	M 8	EA-ST-Plus M 8 x 30	100
EA Plus M 10 x 40	551790	●	12	40	40	15	M 10	EA-ST-Plus M 10 x 40	50
EA Plus M 12 x 50	551791	●	15	50	50	35	M 12	EA-ST-Plus M 12 x 50	50

Technical data

Setting tool EA-ST



EA-ST Plus

Item	Item No. gvz	Sales unit [pcs]
Setting tool EA-ST PLUS M 6 x 25	551792	1
Setting tool EA-ST PLUS M 8 x 30	551793	1
Setting tool EA-ST PLUS M 10 x 40	551794	1
Setting tool EA-ST PLUS M 12 x 50	551795	1

Loads

Hammerset anchor EA Plus

Permissible loads of a single anchor¹⁾ in normal concrete of strength class C20/25.
For the design the complete current assessment ETA-19/0168 has to be considered.

Type	Material/surface ²⁾	Screw material	Effective anchorage depth h_{ef} [mm]	Minimum member thickness h_{min} [mm]	Installation torque T_{inst} [Nm]	Non-cracked concrete			
						Permissible tension (N_{perm}) and shear loads (V_{perm}); minimum spacing (s_{min}) and edge distances (c_{min}) with reduced loads			
						$N_{perm}^{3)}$ [kN]	$V_{perm}^{3)}$ [kN]	$s_{min}^{3)}$ [mm]	$c_{min}^{3)}$ [mm]
EA PLUS M8 x 30	gvz	C8C	30	100	8	1.7	2.6	90	120
EA PLUS M10 x 40	gvz	C8C	40	120	15	2.8	3.3	120	140
EA PLUS M12 x 50	gvz	C8C	50	140	35	4.0	3.6	150	175

¹⁾ Design according to EN 1992-4:2018 (for static resp. quasi-static loads). The partial safety factors for material resistance as regulated in the ETA as well as a partial safety factor for load actions of $\gamma_L = 1.4$ are considered. As a single anchor counts e.g. an anchor with a spacing $s \geq 3 \times h_{ef}$ and an edge distance $c \geq 1.5 \times h_{ef}$. Accurate data see ETA.

²⁾ For details of steel grade and variants, see ETA.

³⁾ In the case of combinations of tension and shear loads, bending moments with reduced or minimal edge and axial spacings (anchor groups), the design must be carried out in accordance with the provisions of the complete ETA and the provisions of the EN 1992-4:2018.

Loads

Hammerset anchor EA Plus

Permissible loads for a single anchor¹⁾ for multiple use of redundant non-structural applications* in normal concrete C20/25 up to C50/60.
For the design the complete current assessment ETA-19/0169 has to be considered.

Type	Material/surface ²⁾	Screw material	Effective anchorage depth h_{ef} [mm]	Minimum member thickness h_{min} [mm]	Maximum torque moment $T_{inst,max}$ [Nm]	Cracked and non-cracked concrete		
						Permissible load (F_{perm}); minimum spacing (s_{min}) and edge distances (c_{min}) with reduced loads		
						$F_{perm}^{3)}$ [kN]	s_{min} [mm]	c_{min} [mm]
EA PLUS M6 x 25	gvz	C8C	25	100	4	0.8	120	110
EA PLUS M8 x 25	gvz	C8C	25	100	8	0.3	100	50
EA PLUS M8 x 30	gvz	C8C	30	100	8	0.8	130	140
EA PLUS M8 x 40	gvz	C8C	40	100	15	0.5	120	80
EA PLUS M10 x 25	gvz	C8C	25	100	15	0.6	110	55
EA PLUS M10 x 30	gvz	C8C	30	100	15	1.0	150	60
EA PLUS M10 x 40	gvz	C8C	40	120	15	1.6	120	90
EA PLUS M12 x 25	gvz	C8C	25	100	35	0.7	200	100
EA PLUS M12 x 50	gvz	C8C	50	140	35	1.2	130	140
EA PLUS M16 x 65	gvz	C8C	65	160	60	2.9	140	125

* In addition to the load table above, the following must be considered for multiple fastening of non-structural redundant systems:

A multiple fixing (redundant system) according to EN 1992-4 and CEN/TR 17079 is defined by

- at least 3 fixing points (per attached element) with at least one anchor at each fixing point and a permissible load per fixing point of 1.4 kN
- or by at least 4 fixing points with at least one anchor each fixing point and a permissible load per fixing point of 2.1 kN
- Additionally, it has to be proven that the stiffness of the attached element shall be large enough to ensure that in case of excessive slip or failure of a fastener the load on this fastener or fixing point can be transferred to neighbouring fixing points without significantly violating the requirements on the attached element in the serviceability and ultimate limit state.

For further details see EN 1992-4 section 7.3 and CEN/TR 17079.

¹⁾ Design according to EN 1992-4:2018 (for static resp. quasi-static loads). The partial safety factors for material resistance as regulated in the ETA as well as a partial safety factor for load actions of $\gamma_L = 1.4$ are considered.

²⁾ For details of steel grade and variants, see ETA.

³⁾ Valid for tensile load, shear load and oblique load under any angle. In the case of combinations of tensile, shear loads and bending moments, the design must be carried out in accordance with the provisions of the complete ETA and the provisions of the EN 1992-4:2018.

Hammerset anchor EA-N

The cost-efficient hammerset anchor for an easy installation

4



Height adjustable pipe installation



Pipelines

Applications

- Pipeline routes
- Cable trays
- Consoles

Advantages

- The hammerset anchor with internal thread is suitable for pre-positioned installation.
- The EA-N fits for all standard screws with

metric/inch – thread.

- The available internal thread diameter from 6 mm to 20 mm provides flexibility in the application.

Building materials

- Concrete C12/15 to C50/60, non-cracked

Versions

- Zinc-plated steel

Functioning

- Put the hammerset anchor in the drill hole and get it flush to the surface by hammering in.
- With the hammerset tool EA-ST the capsule will spread due to hammering in the internal bolt and tensed up against the drill hole wall.
- The hammerset tools must be set up on the edge of the anchor for a correct expansion.

Installation EA-N

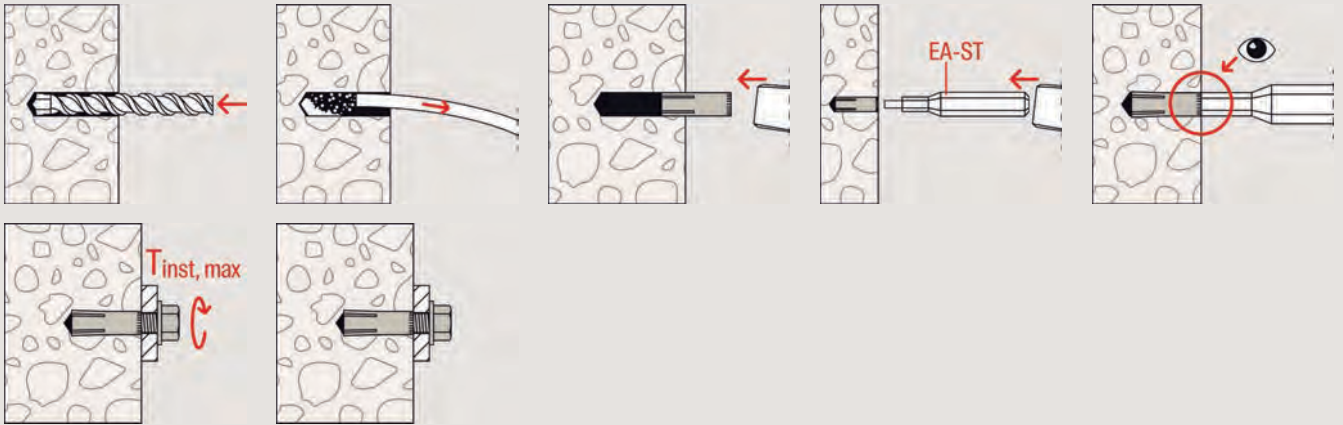

4

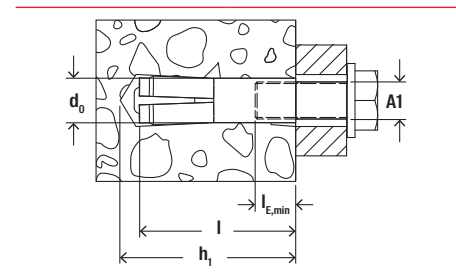

Technical data

Hammerset anchor EA N (metric)



EA-N Metric

Item	Item No.		Min. drill hole depth for pre-positioned installation h_1 [mm]	Anchor length l [mm]	Internal thread A1	Min. bolt penetration $l_{E,min}$ [mm]	Sales unit [pcs]
EA M 6 x 25 N gvz	090159	8	25	25	M 6	6	100
EA M 8 x 30 N gvz	090160	10	30	30	M 8	8	100
EA M10 x 40 N gvz	090161	12	40	40	M 10	10	50
EA M 12 x 50 N gvz	090162	15	50	50	M 12	12	50
EA M 16 x 65 N gvz	090163	20	65	65	M 16	16	25
EA M 20 x 80 N gvz	090164	25	80	80	M 20	20	25
EA M 12 x 50 N D gvz	500872	16	50	50	M 12	12	50

Technical data

EA N (imperial - metric)



EA-N Inch-metric

Item	Item No.	Drill hole diameter d_0 [mm]	Min. drill hole depth for pre-positioned installation h_1 [mm]	Anchor length l [mm]	Internal thread A1	Min. bolt penetration $l_{E,min}$ [mm]	Sales unit [pcs]
EA IM 1/4 x 25 N gvz	048103	8	25	25	1/4"	6	100
EA IM 5/16 x 30 N gvz	048104	10	30	30	5/16"	8	100
EA IM 3/8 x 40 N gvz	048105	12	40	40	3/8"	10	50
EA IM 1/2 x 50 N gvz	048106	16	50	50	1/2"	12	50
EA IM 5/8 x 65 N gvz	048107	20	65	65	5/8"	16	25
EA IM 3/4 x 80 N gvz	048108	25	80	70	3/4"	20	25

Technical data

Hammer set anchor EA N (imperial)



EA-N Inch

Item	Item No.	Drill diameter d_0 [inch]	Min. drill hole depth for pre-positioned installation h_1 [inch]	Total length l [inch]	Internal thread A1 [inch]	Min. bolt penetration $l_{E,min}$ [inch]	Sales unit [pcs]
EA I 1/4 x 1" N gvz	049185	3/8	1	1	1/4	1/4	100
EA I 5/16 x 13/16" N gvz	049194	3/8	1 1/4	1 1/4	5/16	5/16	100
EA I 3/8 x 19/16" N gvz	049195	1/2	1 9/16	1 5/8	3/8	3/8	50
EA I 1/2 x 2" N gvz	049197	5/8	2	2	1/2	1/2	50
EA I 5/8 x 2 1/2" N gvz	049198	3/4	2 3/8	2 1/2	5/8	5/8	20

Technical data

Setting tool EA-ST



EA-ST

Item	Item No.	Match	Sales unit [pcs]
EA-ST 6	504573	EA N M6	1
EA-ST 8	504576	EA N M8	1
EA-ST 10	504584	EA N M10	1
EA-ST 12	504585	EA N M12	1
EA-ST 16	504586	EA N M16	1
EA-ST 20	504587	EA N M20	1

Loads

Hammerset anchor EA-N

Recommended loads¹⁾ of a single anchor in normal concrete of strength class C20/25.

Type	Material/ surface ²⁾	Screw material	Effective anchorage depth h_{ef} [mm]	Minimum member thickness h_{min} [mm]	Maximum installation torque $T_{inst,max}$ [Nm]	Non-cracked concrete		
						Recommended tension load (N_{rec}); minimum spacing (s_{min}) and edge distances (c_{min}) with reduced loads		
						N_{rec} [kN]	$s_{min}^{2)}$ [mm]	$c_{min}^{2)}$ [mm]
EA M6 x 25 N ³⁾	gvz	≥ 4.6	25	100	4	2.0	65	115
EA M8 x 30 N ³⁾	gvz	≥ 4.6	30	100	8	2.5	95	140
EA M10 x 40 N	gvz	≥ 4.6	40	100	15	4.5	150	180
EA M12 x 50 N	gvz	≥ 4.6	50	120	35	6.0	145	200
EA M12 x 50 N D	gvz	≥ 4.6	50	120	35	6.0	145	200
EA M16 x 65 N	gvz	≥ 4.6	65	160	60	11.5	180	240
EA M20 x 80 N	gvz	≥ 4.6	80	200	120	16.0	190	280

¹⁾ Required safety factors are considered.

²⁾ Minimum possible axial spacings resp. edge distance while reducing the recommended load.

³⁾ Only suitable for statically indeterminate systems.

Nail anchor FNA II

The installation-friendly hammer-set anchor for multiple fixings

4

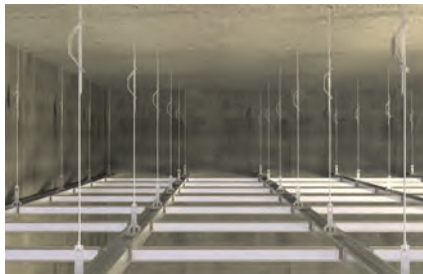

Suspended ceilings



Fire protection boards

Applications

- Fire protection plates
- Fire protection boards
- Ventilation systems
- Wire and nonious hangers
- Mounting rails
- Metal clamps
- Substructures made of wood and metal

Advantages

- The special active principle allows for a simple hammer-set installation and, therefore, a short processing time.
- The extremely short anchor depth prevents reinforcement hits, and creates the conditions for a trouble-free installation.
- The optimised expansion clip ensures hold when placing in the drill hole, and

prevents it falling out during overhead installations.

- The massive shaft cross-section guarantees a high load-bearing capacity, thus offering an extremely high level of safety.
- A range of head shapes allows for the fixing of wide-ranging fixtures, and for the ideal adaptation to suit the intended use.

Certificates



ETA-16/0175, for non-structural applications in concrete



Fire resistance classification R120



RWS



ZTV



INOX STAINLESS STEEL



from M8

Building materials

Approved for:

- Concrete C12/15 to C50/60, cracked, for multiple fixings of non-structural applications

Also suitable for:

- Solid sand-lime brick
- Natural stone with dense structure
- Prestressed hollow-core concrete slabs

Versions

- Zinc-plated steel
- Stainless steel
- Highly corrosion-resistant steel

Functioning

- The FNA II with nail head is suitable for push-through installation. The FNA II M6 is suitable for pre-positioned and push-through installation. The FNA II OE and H are suitable for pre-positioned installation.
- The installed FNA II nail anchor expands automatically under load. The cone is pulled into the expansion clip and expands it against the drill hole wall.
- Available setting tools: FNA S-SBO to slip onto the drill, FNA S-SDS for series installation with a drilling hammer, FNA S-H for the manual installation of mounting rails.

Installation FNA II

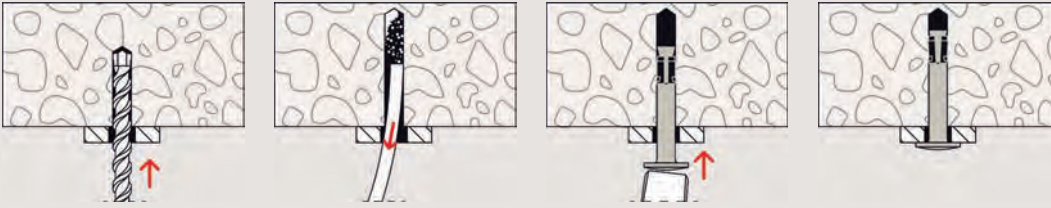

Pre-positioned installation FNA II M6

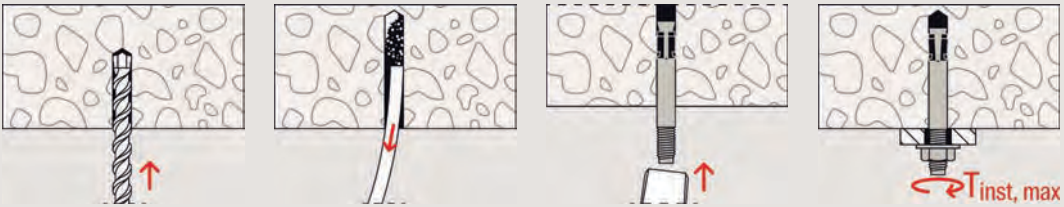

Push-through installation FNA II M6

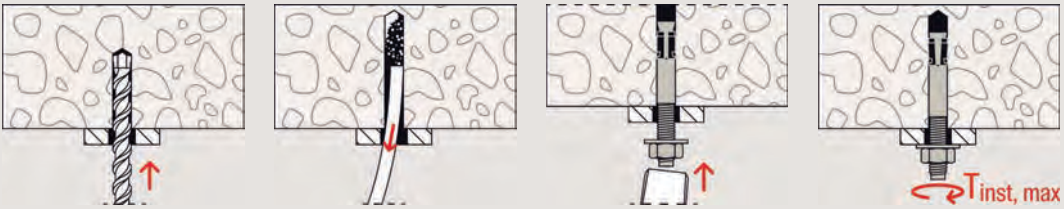

Installation FNA II OE

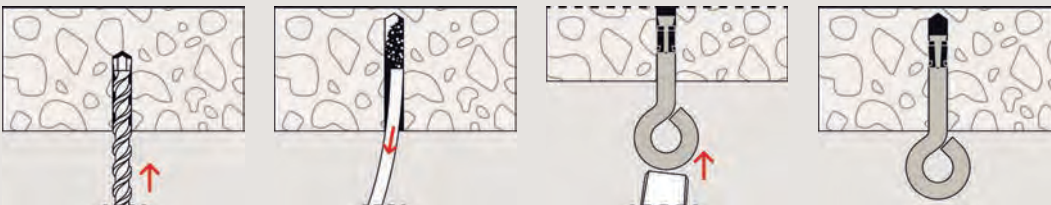

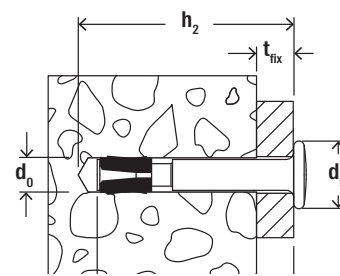

Technical data

Nail anchor FNA II



FNA II with nail head

4

Item	Zinc-plated steel	Stainless steel	Highly corrosion resistant steel	Approval	Drill hole diameter	Min. drill hole depth for through fixings	Anchor length	Max. fixture thickness	Head-Ø	Sales unit
	Item No.	Item No.	Item No.	ETA	d_0 [mm]	h_2 [mm]	l [mm]	t_{fix} [mm]	d_k [mm]	[pcs]
FNA II 6 x 25/5	044121 ¹⁾	—	—	●	6	40	35	5	13.0	100
FNA II 6 x 30/5	044115 ¹⁾	044122	—	●	6	45	40	5	13.0	100
FNA II 6 x 30/5	—	—	044124	●	6	45	40	5	13.0	25
FNA II 6 x 30/15	530419	—	—	●	6	55	50	15	13.0	50
FNA II 6 x 30/30	044116	044123	—	●	6	70	65	30	13.0	50
FNA II 6 x 30/30	—	—	044125	●	6	70	65	30	13.0	25
FNA II 6 x 30/40	—	046023	—	●	6	80	77	40	13.0	50
FNA II 6 x 30/50	044117	046024	500569	●	6	90	85	50	13.0	50
FNA II 6 x 30/60	—	046025	—	●	6	100	97	60	13.0	50
FNA II 6 x 30/75	044118	—	500573 ²⁾	●	6	115	110	75	13.0	50
FNA II 6 x 30/100	044119	—	500574 ²⁾	●	6	140	135	100	13.0	50
FNA II 6 x 30/120	044120	—	500575 ²⁾	●	6	160	155	120	13.0	50

1) With hexagon below the nail head for anti-rotation lock of hole and wire hangers (for example) and centring for optional setting tool FNA II S.

2) Delivery time on request.

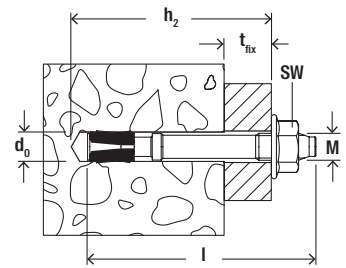

Technical data

Nail anchor FNA II M6



FNA II M6 with thread and flange nut

Item	Zinc-plated steel	Stainless steel	Highly corrosion resistant steel	Approval	Drill hole diameter	Min. drill hole depth for through fixings	Anchor length	Max. fixture thickness	Thread	Width across nut	Sales unit
	Item No.	Item No.	Item No.	ETA	d_0 [mm]	h_2 [mm]	l [mm]	t_{fix} [mm]	M	SW [mm]	[pcs]
FNA II 6 x 25 M6/5	044111	—	—	●	6	40	45	5	M 6	10	100
FNA II 6 x 30 M6/5	044109	—	—	●	6	45	50	5	M 6	10	100
FNA II 6 x 30 M6/5	—	044112 ²⁾	—	●	6	45	50	5	M 6	10	50
FNA II 6 x 30 M6/5	—	—	044113 ²⁾	●	6	45	50	5	M 6	10	25
FNA II 6 x 30 M6 x 41	044110 ¹⁾	—	—	●	6	40	41	—	M 6	10	100
FNA II 6 x 30 M6/10	046022	—	—	●	6	45	55	10	M 6	10	100
FNA II 6 x 30 M8/5	044114	—	—	●	6	45	51	5	M 8	13	50

1) without nut; e.g. for fixing of pipe clamps

2) with nut and washer (no flange nut)

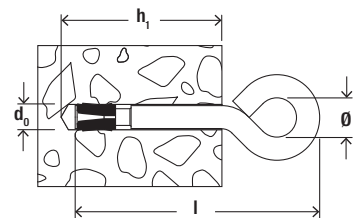

Technical data

Nail anchor FNA II-H / FNA II-OE



FNA II-H with hook

FNA II-OE with eye

Item	Item No.	Approval	Drill hole diameter	Anchor length	Min. drill hole depth	Inner diameter of the hook/eye	Sales unit
		ETA	d_0 [mm]	l [mm]	h_1 [mm]	[Ø mm]	[pcs]
FNA II 6 x 25 H	044126	—	6	54	35	10	50
FNA II 6 x 25 OE	044127	●	6	54	35	10	50

Technical data

Setting tools for FNA II



FNA II S-SDS

FNA II S-SBO

FNA II S-H

Item	Item No.	fits anchor		Sales unit
FNA II S-SDS	061547	for all FNA II with nail head	The ideal setting tool for the serial installation with SDS-plus adapter for driving in FNA II with nail head using a hammer drill.	1
FNA II S-SBO	061548	for all FNA II with nail head	For a power saving and fast installation to be placed on the drill.	1
FNA S-H	095990	for FNA II with metric thread M6	E.g. for the fixing of installation of mounting rails. Chuck with outer diameter of 15 mm for the installation of FNA II M6 by hand.	1

4

Loads

Nail anchor FNA II

Permissible loads for a single anchor¹⁾ for multiple use of redundant non-structural applications* in normal concrete C20/25 up to C50/60²⁾. For the design the complete current assessment ETA-06/0175 has to be considered.

Type	Material/ surface	Effective anchorage depth h_{ef} [mm]	Minimum member thick- ness h_{min} [mm]	Maximum installation torque $T_{inst,max}$ [Nm]	Cracked and non-cracked concrete		
					Permissible load (F_{perm}); minimum spacing (s_{min}) and edge distances (c_{min}) with reduced loads		
					$F_{perm}^{3)}$ [kN]	s_{min} [mm]	c_{min} [mm]
FNA II 6 x 25	gvz	25	80	-	1.4	40	40
FNA II 6 x 30	gvz	30	80	-	2.4	40	40
	R	30	80	-	2.4	40	40
	HCR	30	80	-	2.4	40	40
FNA 6 x 25 M6	gvz	25	80	4	1.4	40	40
FNA 6 x 30 M6	gvz	30	80	4	2.4	40	40
	R	30	80	4	2.4	40	40
	HCR	30	80	4	2.4	40	40
FNA II 6 x 30 M8	gvz	30	80	4	2.4	40	40
FNA II 6 x 25 OE	gvz	25	80	-	0.7	40	40

* In addition to the load table above, the following must be considered for multiple fastening of non-structural redundant systems:

A multiple fixing (redundant system) according to EN 1992-4 and CEN/TR 17079 is defined by

- at least 3 fixing points (per attached element) with at least one anchor at each fixing point and a permissible load per fixing point of 1.4 kN

- or by at least 4 fixing points with at least one anchor each fixing point and a permissible load per fixing point of 2.1 kN

- Additionally, it has to be proven that the stiffness of the attached element shall be large enough to ensure that in case of excessive slip or failure of a fastener the load on this fastener or fixing point can be transferred to neighbouring fixing points without significantly violating the requirements on the attached element in the serviceability and ultimate limit state.

For further details see EN 1992-4 section 7.3 and CEN/TR 17079.

¹⁾ Design according to EN 1992-4:2018 (for static resp. quasi-static loads). The partial safety factors for material resistance as regulated in the ETA as well as a partial safety factor for load actions of $\gamma_L = 1.4$ are considered.

²⁾ For concrete strength class C12/15 see ETA.

³⁾ Valid for tensile load, shear load and oblique load under any angle. In the case of combinations of tensile, shear loads and bending moments, the design must be carried out in accordance with the provisions of the complete ETA and the provisions of the EN 1992-4:2018.

Nail anchor FNA II RB

The easy-to-assemble fixing solution for removable fire protection panel



Fire protection boards



Fire protection boards

4

Applications

- Fixing of fire protection panel in tunnel construction.
- For fixing of one and more layers of fire protection panel of all manufacturers e.g. Aestuver and Promat.

Advantages

- Easy removal of fire protection panel without damage.
- Reusability of removed fire protection panel.
- Secure fixing, particularly when exposed to vibration, wind and pushing/pulling effects.
- Easy-to-assemble solution.
- Low anchoring depth (30 mm).
- Convenient assembly without torque-controlled setting tool.
- Approved system which has proven itself one million times over.
- Large range of anchor lengths possible.

Certificates



ETA-16/0175, for non-structural applications in concrete



Fire resistance classification R120



RWS



ZTV



INOX STAINLESS STEEL



from M8

Building materials

- Concrete C12/15 to C50/60, cracked and non-cracked, for multiple fixings of non-structural applications

Versions

- Stainless steel R
- Highly corrosion-resistant steel HCR

Functioning

- Nail anchor with low anchoring depth.
- The washer increases the pull through forces significantly and provides the damage of the panel during dismantling.
- Mounting: Drill, hammer in, and you're done!
- Easy pinching off of nail head thanks to special 2-stage pliers.
- For a fast assembly process, we recommend the fischer compressed air setting device (item no. 093731).

Installation FNA II RB



Deinstallation

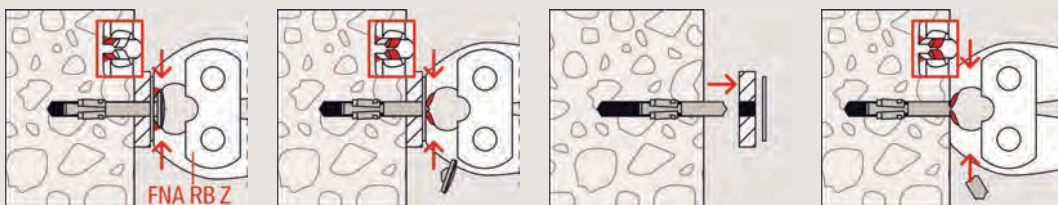

4

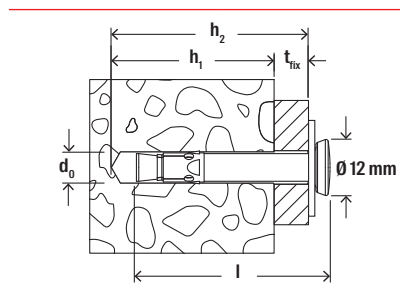

Technical data

Nail anchor FNA II RB



FNA II RB

Item	Stainless steel	Approval	Drill hole diameter	Min. drill hole depth for through fixings	Min. drill hole depth for pre-positioned installation	Anchorage depth	Anchor length	Max. usable length	Sales unit
	Item No.		d_0 [mm]	h_2 [mm]	h_1 [mm]	h_{ef} [mm]	l [mm]	t_{fix} [mm]	[pcs]
FNA II 6 x30/30 RB	530798 ¹⁾	●	6	66	36	30	68	30	200
FNA II 6 x30/30 RB	530674 ¹⁾	●	6	66	36	30	68	30	50

¹⁾ delivery on request

Technical data

Washer (FNA II RB)



Washer 30/1,5/7,5

	Stainless steel	Highly corrosion resistant steel	Internal diameter	External-Ø	Thickness	Sales unit
Item	Item No.	Item No.	D [mm]	d [mm]	S [mm]	[pcs]
Washer 30/1,5/7,5	R 531161	HCR 531162	7,5	30	1.5	100

Technical data

2-stage plier (FNA II RB)



FNA RB Z 2-stage plier

	Item No.	Adapted for	Sales unit [pcs]
FNA RB Z	531142	Plier for removal of FNA II RB	1

Technical data

Air compressed setting tool (FNA II)



Air compressed setting tool

	Item No.	Match	Required for	Sales unit [pcs]
Air compressed setting tool	093731	for FNA II + FNA II RB	—	1
Drop in element	093729	—	Air compressed setting tool Art No. 93731	1
Stop ring	093730	—	Air compressed setting tool Art No. 93731	1
Fitting	093732	—	Air compressed setting tool Art No. 93731	1

Loads

Nail anchor FNA II RB

Permissible loads for a single anchor¹⁾ for multiple use of redundant non-structural applications* in normal concrete C20/25 up to C50/60²⁾. For the design the complete current assessment ETA-06/0175 has to be considered.

Type	Material/ surface	Effective anchorage depth h_{ef} [mm]	Minimum member thickness h_{min} [mm]	Cracked and non-cracked concrete		
				Permissible load (F_{perm}); minimum spacing (s_{min}) and edge distances (c_{min}) with reduced loads		
				F_{perm} ³⁾ [kN]	s_{min} [mm]	c_{min} [mm]
FNA II 6 x 30 RB	R	30	80	2.4	40	40
	HCR	30	80	2.4	40	40

* In addition to the load table above, the following must be considered for multiple fastening of non-structural redundant systems:

A multiple fixing (redundant system) according to EN 1992-4 and CEN/TR 17079 is defined by

- at least 3 fixing points (per attached element) with at least one anchor at each fixing point and a permissible load per fixing point of 1.4 kN
- or by at least 4 fixing points with at least one anchor each fixing point and a permissible load per fixing point of 2.1 kN

- Additionally, it has to be proven that the stiffness of the attached element shall be large enough to ensure that in case of excessive slip or failure of a fastener the load on this fastener or fixing point can be transferred to neighbouring fixing points without significantly violating the requirements on the attached element in the serviceability and ultimate limit state.

For further details see EN 1992-4 section 7.3 and CEN/TR 17079.

¹⁾ Design according to EN 1992-4:2018 (for static resp. quasi-static loads). The partial safety factors for material resistance as regulated in the ETA as well as a partial safety factor for load actions of $\gamma_L = 1.4$ are considered.

²⁾ For concrete strength class C12/15 see ETA.

³⁾ Valid for tensile load, shear load and oblique load under any angle. In the case of combinations of tensile, shear loads and bending moments, the design must be carried out in accordance with the provisions of the complete ETA and the provisions of the EN 1992-4:2018.

Ceiling nail FDN II

The installation-friendly push-through anchor for multiple fixings



Suspended ceilings



Suspended ceilings with Nonius hangers

4

Applications

- Wire and Nonius hangers
- Ventilation systems
- Slats
- Metal profiles
- Perforated tapes
- Sub-structures made of metal

Certificates



ETA-17/0736, for non-structural applications in concrete



Fire resistance classification R120

Advantages

- The simple active principle allows for cost-efficient hammer-set installation.
- The new short version FDN II K with reduced anchorage depth is faster to install and reduces reinforcement hits.
- The flush-sunk expansion nail signifies the complete expansion of the anchor,

Building materials

Approved for:

- Concrete C12/15 to C50/60
- Concrete C20/25 to C50/60, cracked, for the multiple fixings of non-load-bearing systems

Also suitable for:

- Natural stone with dense structure

Versions

- Zinc-plated steel

and thereby ensures minimum movement when under load.

- The Fischer FDN II can be installed without cleaning of the drill hole.
- The head embossing offers a simple control of the anchoring, and thus saves time.

Functioning

- The FDN II is suitable for push-through installation.
- The FDN II ceiling nail is driven into the drill hole with a hammer until it is firmly in position. Do not hit the expansion wedge at this stage.
- Then, drive the expansion wedge in flush to the nail head. This causes the FDN II to expand against the drill hole wall.

Installation FDN II

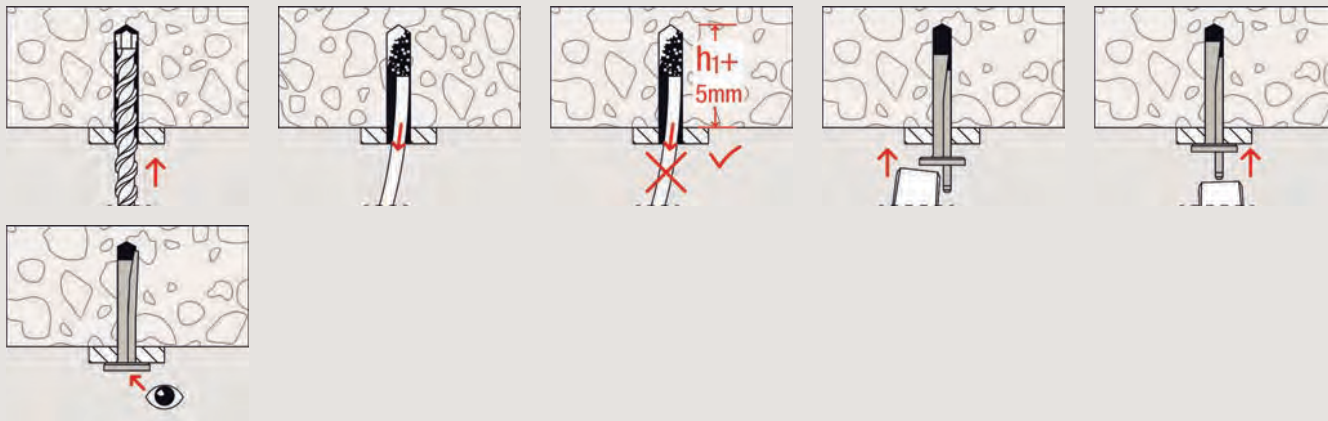

4

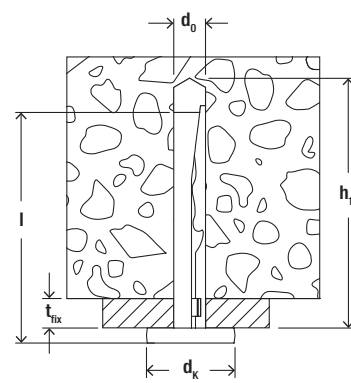

Technical data

Ceiling nail FDN II



FDN II

Item	Item No.	Approval	Drill diameter	Anchor length	Max. usable length	Min. drill hole depth without cleaning	Min. drill hole depth with cleaning	Head-Ø	Sales unit
			d_0 [mm]	l [mm]	t_{fix} [mm]	h_1 [mm]	h_1 [mm]	d_k [mm]	[pcs]
		ETA							
FDN II 6/5	545636	●	6	40	5	47	42	15	100
FDN II 6/35	545637	●	6	70	35	77	72	15	100
FDN II 6/5 K	545638	●	6	33	5	40	35	15	100
FDN II 6/35 K	545639	●	6	64	35	70	65	15	100

Loads

Ceiling Anchor FDN II

Permissible loads for a single anchor¹⁾ for multiple use of redundant non-structural applications* in normal concrete C20/25 up to C50/60²⁾. For the design the complete current assessment ETA-17/0736 has to be considered.

Type	Material/ surface	Effective anchorage depth h_{ef} [mm]	Minimum member thickness h_{min} [mm]	Cracked and non-cracked concrete		
				Permissible load (F_{perm}); minimum spacing (s_{min}) and edge distances (c_{min}) with reduced loads		
				F_{perm} ³⁾ [kN]	s_{min} [mm]	c_{min} [mm]
FDN II 6/5 K	gvz	25	80	1.2	60	70
FDN II 6/35 K	gvz	25	80	1.2	60	70
FDN II 6/5	gvz	32	80	1.7	50	60
FDN II 6/35	gvz	32	80	1.7	50	60

* In addition to the load table above, the following must be considered for multiple fastening of non-structural redundant systems:

A multiple fixing (redundant system) according to EN 1992-4 and CEN/TR 17079 is defined by

- at least 3 fixing points (per attached element) with at least one anchor at each fixing point and a permissible load per fixing point of 1.4 kN
- or by at least 4 fixing points with at least one anchor each fixing point and a permissible load per fixing point of 2.1 kN

- Additionally, it has to be proven that the stiffness of the attached element shall be large enough to ensure that in case of excessive slip or failure of a fastener the load on this fastener or fixing point can be transferred to neighbouring fixing points without significantly violating the requirements on the attached element in the serviceability and ultimate limit state.

For further details see EN 1992-4 section 7.3 and CEN/TR 17079.

¹⁾ Design according to EN 1992-4:2018 (for static resp. quasi-static loads). The partial safety factors for material resistance as regulated in the ETA as well as a partial safety factor for load actions of $\gamma_L = 1.4$ are considered.

²⁾ For concrete strength class C12/15 see ETA.

³⁾ Valid for tensile load, shear load and oblique load under any angle. In the case of combinations of tensile, shear loads and bending moments, the design must be carried out in accordance with the provisions of the complete ETA and the provisions of the EN 1992-4:2018.

Ceiling nail FDZ

The cost-efficient push-through anchor for multiple fixings



Suspended ceilings with Nonius hangers



Drywall profiles

4

Applications

- Drywall profiles
- Wire and Nonius hangers
- Ventilation systems
- Slats
- Metal profiles
- Perforated tapes
- Sub-structures made of metal

Certificates



ETA-17/0737, for non-structural applications in concrete



Fire resistance classification R120

Advantages

- The simple active principle allows for fast hammer-set installation.
- The efficient anchor offers the perfect price-performance ratio for an economical installation.
- The flush-sunk expansion nail signifies

- the complete expansion of the anchor, and thereby ensures minimum movement when under load.
- The head embossing offers a simple control of the anchoring, and thus saves time.

Building materials

Approved for:

- Concrete C20/25 to C50/60, cracked, for the multiple fixings of non-load-bearing systems

Also suitable for:

- Concrete C12/15
- Natural stone with dense structure

Versions

- Zinc-plated steel

Functioning

- The FDZ is suitable for push-through installation.
- The FDZ ceiling nail is driven into the drill hole with a hammer until it is firmly in position. Do not hit the expansion wedge at this stage.
- Then, drive the expansion wedge in flush to the nail head. This causes the FDZ to expand against the drill hole wall.

Installation FDZ



4

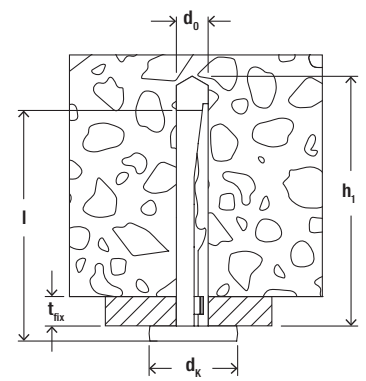

Technical data

Ceiling nail FDZ



FDZ

Item	Item No.	Approval	Drill diameter	Anchor length	Max. usable length	Min. drill hole depth without cleaning	Min. drill hole depth with cleaning	Head-Ø	Sales unit
			d_0 [mm]	l [mm]	t_{fix} [mm]	h_1 [mm]	h_1 [mm]	d_k [mm]	
		ETA							
FDZ 6/5	554899	●	6	40	5	47	42	15	100
FDZ 6/35	554898	●	6	70	35	77	72	15	100

Loads

Ceiling nail FDZ

Permissible loads for a single anchor¹⁾ for multiple use of redundant non-structural applications* in normal concrete C20/25 up to C50/60²⁾. For the design the complete current assessment ETA-17/0737 has to be considered.

Type	Material/ surface	Effective anchorage depth h_{ef} [mm]	Minimum member thickness h_{min} [mm]	Cracked and non-cracked concrete		
				Permissible load (F_{perm}); minimum spacing (s_{min}) and edge distances (c_{min}) with reduced loads		
				$F_{perm}^{3)}$ [kN]	s_{min} [mm]	c_{min} [mm]
FDZ 6	gvz	25	80	0.7	60	70
FDZ 6	gvz	32	80	1.0	50	60

* In addition to the load table above, the following must be considered for multiple fastening of non-structural redundant systems:

A multiple fixing (redundant system) according to EN 1992-4 and CEN/TR 17079 is defined by

- at least 3 fixing points (per attached element) with at least one anchor at each fixing point and a permissible load per fixing point of 1.4 kN

- or by at least 4 fixing points with at least one anchor each fixing point and a permissible load per fixing point of 2.1 kN

- Additionally, it has to be proven that the stiffness of the attached element shall be large enough to ensure that in case of excessive slip or failure of a fastener the load on this fastener or fixing point can be transferred to neighbouring fixing points without significantly violating the requirements on the attached element in the serviceability and ultimate limit state.

For further details see EN 1992-4 section 7.3 and CEN/TR 17079.

¹⁾ Design according to EN 1992-4:2018 (for static resp. quasi-static loads). The partial safety factors for material resistance as regulated in the ETA as well as a partial safety factor for load actions of $\gamma_L = 1.4$ are considered.

²⁾ For concrete strength class C12/15 see ETA.

³⁾ Valid for tensile load, shear load and oblique load under any angle. In the case of combinations of tensile, shear loads and bending moments, the design must be carried out in accordance with the provisions of the complete ETA and the provisions of the EN 1992-4:2018.

Bolt anchor FBN II

The cost-efficient fixing for flexible use in non-cracked concrete



Column bases



Stormwater overflow tank manholes

4

Applications

- Steel constructions
- Guard rails
- Consoles
- Ladders
- Cable trays
- Machines
- Staircases
- Gates
- Façades

Advantages

- The standard anchorage depth achieves the maximum load-bearing capacities.
- The reduced anchorage depth reduces the drill hole depth. This minimises the amount of time needed for installation whilst increasing flexibility.
- Additional short version "K" with short anchoring depth.
- The long thread balances component tolerances and allows for stand-off installations, thus increasing flexibility.
- Few hammer blows and the minimal torque slippage allow for a noticeably

- simpler installation.
- The drive-in pin protects the thread from damage, and thus ensures a faster installation and dismantling of the attachment.
- The larger washer included with the FBN II GS creates a larger supporting surface and, as such, allows for the fixing of wood constructions.
- When using hollow drills with suction is no drill hole cleaning required.
- New ETA assessment for hot-dip galvanised version for variable working life in outdoor areas.

Certificates



ETA-07/0211, for non-cracked concrete
ETA-18/0101, for non-cracked concrete and variable working life for outdoor areas



INOX STAINLESS STEEL

Building materials

Approved for:

- Concrete C20/25 to C50/60, non-cracked

Also suitable for:

- Concrete C12/15
- Natural stone with dense structure

Versions

- Zinc-plated steel
- Stainless steel R
- Hot-dip galvanised steel (with variable working life for outdoor areas)

Functioning

- The FBN II is suitable for pre-positioned and push-through installation; also suitable for stand-off installation under certain conditions.
- Prior to installation, place the hexagon nut in the optimal position (the drive-in pin projects by approx. 3 mm out of the hexagon nut).
- When applying the torque, the cone bolt is pulled into the expansion clip and expands it against the drill hole wall.
- The head embossing offers a simple control of the anchoring.
- In the case of series installation, we recommend using the FABS bolt anchor setting tool.

Installation FBN II

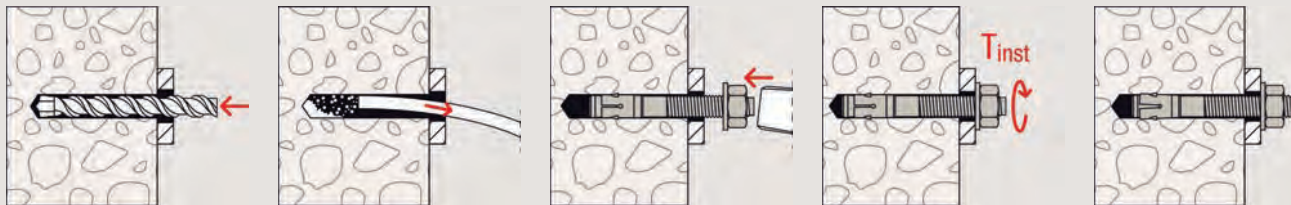

4

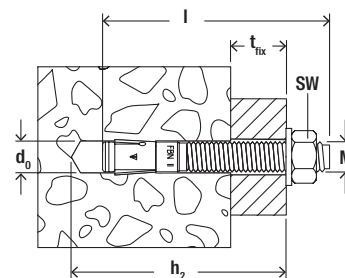

Technical data

Bolt anchor FBN II



FBN II

Item	Zinc-plated steel	Stainless steel	Hot-dip galvanised steel	Approval	Drill hole diameter	Min. drill hole depth for through fixings	Anchor length	Max. usable length hef,max./ hef,min.	Thread	Width across nut	Sales unit
	Item No.	Item No.	Item No.		d_0 [mm]	h_2 [mm]	l [mm]	t_{fix} [mm]	\emptyset x length [mm]	SW [mm]	[pcs]
	gvz	R	hdg	ETA							
FBN II 6/5	505526 ¹⁾²⁾	—	—	●	6	45	50	5/-	M 6 x 12	10	100
FBN II 6/10	505527 ¹⁾²⁾	505532 ¹⁾²⁾	—	●	6	50	55	10/-	M 6 x 17	10	100
FBN II 6/30	505528 ¹⁾²⁾	505535 ¹⁾²⁾	—	●	6	70	75	30/-	M 6 x 35	10	100
FBN II 8/5	040662	—	—	●	8	61	65	5/15	M 8 x 34	13	50
FBN II 8/10	040664	507555	—	●	8	66	70	10/20	M 8 x 39	13	50
FBN II 8/10	—	—	507575	●	8	66	71	10/20	M 8 x 39	13	50
FBN II 8/20	040669	—	—	●	8	76	80	20/30	M 8 x 49	13	50
FBN II 8/30	040700	507556	—	●	8	86	90	30/40	M 8 x 59	13	50
FBN II 8/30	—	—	507576	●	8	86	91	30/40	M 8 x 59	13	50
FBN II 8/50	040771	507557	—	●	8	106	110	50/60	M 8 x 79	13	50
FBN II 8/50	—	—	507577	●	8	106	111	50/60	M 8 x 79	13	50
FBN II 8/70	040777	—	—	●	8	126	130	70/80	M 8 x 99	13	20
FBN II 8/70	—	—	507578	●	8	126	131	70/80	M 8 x 99	13	20
FBN II 8/100	040783	—	—	●	8	156	160	100/110	M 8 x 129	13	20
FBN II 10/10	040827	507558	—	●	10	78	85	10/20	M 10 x 46	17	50
FBN II 10/10	—	—	507579	●	10	78	86	10/20	M 10 x 46	17	50
FBN II 10/20	040851	507559	—	●	10	88	95	20/30	M 10 x 56	17	50
FBN II 10/30	040854	507560	—	●	10	98	105	30/40	M 10 x 66	17	50
FBN II 10/30	—	—	507580	●	10	98	106	30/40	M 10 x 66	17	50
FBN II 10/50	040855	507561	—	●	10	118	125	50/60	M 10 x 86	17	20
FBN II 10/50	—	—	507582	●	10	118	126	50/60	M 10 x 86	17	20
FBN II 10/70	040931	—	—	●	10	138	145	70/80	M 10 x 106	17	20
FBN II 10/100	040943	507562	—	●	10	168	175	100/110	M 10 x 136	17	20
FBN II 10/100	—	—	507583	●	10	168	176	100/110	M 10 x 136	17	20
FBN II 10/140	040944	—	—	●	10	208	215	140/150	M 10 x 176	17	20

1) Use restricted to anchoring of structural components which are statically indeterminate.

2) Nut and washer not pre-assembled/supplied loose.

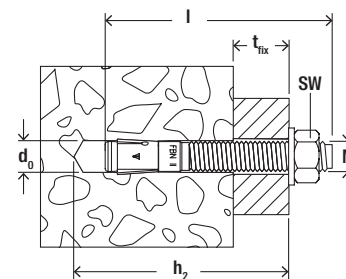

Technical data

Bolt anchor FBN II



FBN II

Item	Zinc-plated steel	Stainless steel	Hot-dip galvanised steel	Approval	Drill hole diameter	Min. drill hole depth for through fixings	Anchor length	Max. usable length hef,max./ hef,min.	Thread	Width across nut	Sales unit
	Item No.	Item No.	Item No.	ETA	d ₀ [mm]	h ₂ [mm]	l [mm]	t _{fix} [mm]	Ø x length [mm]	SW [mm]	[pcs]
FBN II 10/160	040945	—	—	●	10	228	235	160/170	M 10 x 196	17	20
FBN II 12/10	040950	507563	—	●	12	95	104	10/25	M 12 x 59	19	20
FBN II 12/10	—	—	507589	●	12	95	106	10/25	M 12 x 59	19	20
FBN II 12/20	044558	507564	—	●	12	105	114	20/35	M 12 x 69	19	20
FBN II 12/30	045263	507565	—	●	12	115	124	30/45	M 12 x 79	19	20
FBN II 12/30	—	—	507591	●	12	115	126	30/45	M 12 x 79	19	20
FBN II 12/50	045264	507566	—	●	12	135	144	50/65	M 12 x 99	19	20
FBN II 12/50	—	—	507592	●	12	135	146	50/65	M 12 x 99	19	20
FBN II 12/80	045265	—	—	●	12	165	174	80/95	M 12 x 129	19	20
FBN II 12/100	045266	507567	—	●	12	185	194	100/115	M 12 x 149	19	20
FBN II 12/100	—	—	507596	●	12	185	196	100/115	M 12 x 149	19	20
FBN II 12/120	045267	—	—	●	12	205	214	120/135	M 12 x 169	19	20
FBN II 12/140	045268	—	—	●	12	225	234	140/155	M 12 x 189	19	20
FBN II 12/160	045269	—	—	●	12	245	254	160/175	M 12 x 189	19	20
FBN II 16/10	—	507568	—	●	16	114	128	10/25	M 16 x 74	24	10
FBN II 16/25	—	—	507598	●	16	129	145	25/40	M 16 x 89	24	10
FBN II 16/25	045564	507569	—	●	16	129	143	25/40	M 16 x 89	24	10
FBN II 16/50	—	—	507553	●	16	154	170	50/65	M 16 x 105	24	10
FBN II 16/50	045565	507570	—	●	16	154	168	50/65	M 16 x 105	24	10
FBN II 16/80	045566	—	—	●	16	184	198	80/95	M 16 x 144	24	10
FBN II 16/100	045567	—	—	●	16	204	218	100/115	M 16 x 164	24	10
FBN II 16/100	—	—	507554	●	16	204	220	100/115	M 16 x 164	24	10
FBN II 16/140	045568	—	—	●	16	244	258	140/155	M 16 x 184	24	10
FBN II 16/160	045569	—	—	●	16	264	278	160/175	M 16 x 184	24	10
FBN II 16/200	045570	—	—	●	16	304	318	200/215	M 16 x 184	24	10
FBN II 20/30	045573	507571	508015	●	20	165	187	30/55	M 20 x 90	30	10
FBN II 20/60	045574	507572	—	●	20	195	217	60/85	M 20 x 90	30	10
FBN II 20/80	045575	547590	—	●	20	215	237	80/105	M 20 x 90	30	10
FBN II 20/120	045576	—	—	●	20	255	277	120/145	M 20 x 90	30	10

1) Use restricted to anchoring of structural components which are statically indeterminate.

2) Nut and washer not pre-assembled/supplied loose.

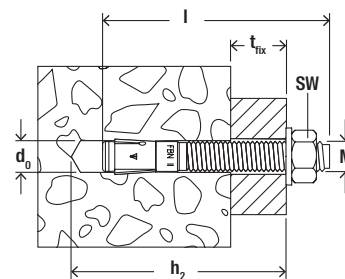

Technical data

Bolt anchor FBN II K

4



FBN II K

Item	Zinc-plated steel, short version	Stainless steel, short version	Hot-dip galvanised steel, short version	Approval	Drill hole diameter	Min. drill hole depth for through fixings	Anchor length	Max. usable length hef,max./ hef,min.	Thread	Width across nut	Sales unit
	Item No.	Item No.	Item No.		d_0 [mm]	h_2 [mm]	l [mm]	t_{fix} [mm]	$\emptyset \times$ length [mm]	SW [mm]	[pcs]
	gvz	R	hdg	ETA							
FBN II 8/5 K	—	—	508012	●	8	51	56	-/5	M 8 x 24	13	50
FBN II 8/5 K	040806	508007	—	●	8	51	55	-/5	M 8 x 24	13	50
FBN II 8/10 K	040807	—	—	●	8	56	60	-/10	M 8 x 29	13	50
FBN II 10/5 K	040946	508010	—	●	10	63	70	-/5	M 10 x 31	17	50
FBN II 10/5 K	—	—	508013	●	10	63	71	-/5	M 10 x 31	17	50
FBN II 10/10 K	040947	—	—	●	10	68	75	-/10	M 10 x 36	17	50
FBN II 12/5 K	045272	508011	—	●	12	75	84	-/5	M 12 x 39	19	20
FBN II 12/5 K	—	—	508014	●	12	75	86	-/5	M 12 x 39	19	20
FBN II 12/10 K	045273	—	—	●	12	80	89	-/10	M 12 x 44	19	20
FBN II 12/30 K	045274	—	—	●	12	100	109	-/30	M 12 x 64	19	20
FBN II 16/15 K	045571	508745	—	●	16	104	118	-/15	M 16 x 64	24	10
FBN II 16/15 K	—	—	507597	●	16	104	120	-/15	M 16 x 64	24	10
FBN II 16/25 K	045572	—	—	●	16	114	128	-/25	M 16 x 74	24	10
FBN II 20/10 K	045577	—	543973	●	20	120	142	-/10	M 20 x 50	30	10

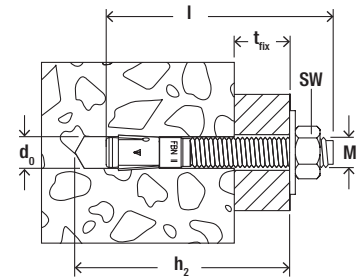

Technical data

Bolt anchor FBN II GS



FBN II-GS with large washer

Item	Steel, zinc-plated, with large washer	Stainless steel, with large washer	Approval	Drill hole diameter	Min. drill hole depth for through fixings	Anchor length	Max. usable length hef,max./hef,min.	Thread	Width across nut	Washer (outer diameter x thickness)	Sales unit
	Item No.	Item No.		d_0 [mm]	h_2 [mm]	l [mm]	t_{fix} [mm]	\emptyset x length [mm]	SW [mm]	[mm]	[pcs]
	gvz	R	ETA								
FBN II 8/10 GS	—	513305	●	8	66	70	10/20	M 8 x 39	13	44 x 4	50
FBN II 12/80 GS	045578	—	●	12	165	174	80/95	M 12 x 129	19	44 x 4	20
FBN II 12/100 GS	045579	—	●	12	185	194	100/115	M 12 x 149	19	44 x 4	20
FBN II 12/120 GS	045580	—	●	12	205	214	120/135	M 12 x 169	19	44 x 4	20
FBN II 12/140 GS	045581	—	●	12	225	234	140/155	M 12 x 189	19	44 x 4	10
FBN II 12/160 GS	045583	—	●	12	245	254	160/175	M 12 x 189	19	44 x 4	10
FBN II 12/180 GS	045584	—	●	12	265	274	180/195	M 12 x 189	19	44 x 4	10
FBN II 12/200 GS	045585	—	●	12	285	294	200/215	M 12 x 189	19	44 x 4	10
FBN II 12/250 GS	045586	—	●	12	335	344	250/265	M 12 x 100	19	44 x 4	10
FBN II 16/100 GS	045588	—	●	16	204	218	100/115	M 16 x 164	24	56 x 5	10
FBN II 16/140 GS	045590	—	●	16	244	258	140/155	M 16 x 184	24	56 x 5	10
FBN II 16/160 GS	045591	—	●	16	264	278	160/175	M 16 x 184	24	56 x 5	10
FBN II 16/200 GS	045593	—	●	16	304	318	200/215	M 16 x 100	24	56 x 5	10

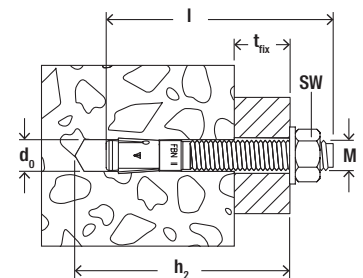

Technical data

Bolt anchor FBN II K GS



FBN II K GS

Item	Item No.	Approval	Drill hole diameter	Min. drill hole depth for through fixings	Anchor length	Max. usable length hef,-max./hef,min.	Thread	Width across nut	Sales unit
		ETA	d_0 [mm]	h_2 [mm]	l [mm]	t_{fix} [mm]	\emptyset x length [mm]	SW [mm]	[pcs]
FBN II 8/5 K GS	558204	●	8	51	55	-/5	M 8 x 24	13	50
FBN II 10/10 K GS	558205	●	10	68	75	-/10	M 10 x 36	17	50
FBN II 12/10 K GS	558206	●	12	80	89	-/10	M 12 x 44	19	20

Accessories

Bolt anchor setting tool



Item	Item No.	Contents	Matching anchor type	Sales unit [pcs]
FABS	077937	—	FAZ II, FBZ, FBN II for diameter from M6 - M12	1
FA-ST II Set	558789	SDS adapter; socket SW17, SW19, SW24	FAZ II M10/M12/M16, FBZ M10/M12/M16, FBN II M10/M12/M16, EXA M10/M12/M16	1
FA-ST II M10	558790	SDS adapter; socket SW17	FAZ II M10, FBZ M10, FBN II M10, EXA M10	1
FA-ST II M12	558791	SDS adapter; socket SW19	FAZ II M12, FBZ M12, FBN II M12, EXA M12	1
FA-ST II M16	558792	SDS adapter; socket SW24	FAZ II M16, FBZ M16, FBN II M16, EXA M16	1
FA-ST II spring	558793	Replacement spring	FA-ST II M10/M12/M16	5

Loads

Bolt anchor FBN II

Permissible loads of a single anchor¹⁾ in normal concrete of strength class C20/25. For the design the complete current assessment ETA-07/0211 has to be considered.

Type	Material/surface ²⁾	Effective anchorage depth h_{ef} [mm]	Minimum member thickness h_{min} [mm]	Installation torque T_{inst} [Nm]	Non-cracked concrete			
					Permissible tension (N_{perm}) and shear loads (V_{perm}); minimum spacing (s_{min}) and edge distances (c_{min}) with reduced loads			
					N_{perm} ³⁾ [kN]	V_{perm} ³⁾ [kN]	s_{min} ³⁾ [mm]	c_{min} ³⁾ [mm]
FBN II 8	gvz	30	100	15	2.9	6.9	40	40
	gvz	40	100	15	5.9	7.6	40	40
	R	30	100	10	2.9	6.9	50	45
	R	40	100	10	5.9	7.3	40	45
FBN II 10	gvz	40	100	30	5.9	12.0	50	80
	gvz	50	100	30	8.3	12.0	50	50
	R	40	100	20	5.9	11.6	50	80
	R	50	100	20	8.3	11.6	70	55
FBN II 12	gvz	50	100	50	8.3	17.9	70	100
	gvz	65	120	50	12.3	17.9	70	70
	R	50	100	35	8.3	15.7	70	100
	R	65	120	35	12.3	15.7	70	70
FBN II 16	gvz	65	120	100	12.3	28.2	90	120
	gvz	80	160	100	16.8	31.5	90	90
	R	65	120	80	12.3	28.2	90	120
	R	80	160	80	16.8	29.1	120	80
FBN II 20	gvz	80	160	200	16.8	38.3	120	120
	gvz	105	200	200	25.2	38.3	120	120
	R	80	160	150	16.8	38.6	140	120
	R	105	200	150	25.2	49.1	120	120

¹⁾ Design according to EN 1992-4:2018 (for static resp. quasi-static loads). The partial safety factors for material resistance as regulated in the ETA as well as a partial safety factor for load actions of $\gamma_L = 1.4$ are considered. As a single anchor counts e.g. an anchor with a spacing $s \geq 3 \times h_{ef}$ and an edge distance $c \geq 1.5 \times h_{ef}$. Accurate data see ETA.

²⁾ Further steel grades, versions and technical data see ETA, e.g. for dry internal conditions, galvanised steel (gvz); for damp interiors and for outdoor use, stainless steel (R).

³⁾ In the case of combinations of tension and shear loads, bending moments with reduced or minimum spacing and edge distances (anchor groups), the design must be carried out in accordance with the provisions of the complete ETA and the provisions of the EN 1992-4:2018. We recommend using our anchor design software C-FIX.

Bolt anchor FXA

Cost efficient fixing with ETA assessment for non-cracked concrete



Banisters



Steel girders

4

Applications

- Steel constructions
- Guard rails
- Consoles
- Ladders
- Cable trays
- Machines
- Staircases
- Gates
- Façades

Certificates



ETA-13/0772, for non-cracked concrete



INOX STAINLESS STEEL

Advantages

- The standard anchorage depth achieves the maximum loadbearing capacities so fewer fixing points and smaller anchor plates are required.
- With only a few hammer blows and

minimal torque slippage installation is a simple process.

- The drive-in pin protects the thread from damage, and ensures a faster installation and dismantling of the attachment.

Building materials

Approved for:

- Concrete C20/25 to C50/60, non-cracked

Versions

- Zinc-plated steel

Functioning

- The FXA is suitable for pre-positioned and push through installation, also suitable for stand off installation under certain conditions.
- Prior to installation, place the hexagon nut in the optimal position (the drive-in pin projects by approx. 3 mm out of the hexagon nut).
- When applying the torque, the cone bolt is pulled into the expansion clip and expands it against the drill hole wall.
- The head embossing offers a simple control of the anchoring.

Installation FXA

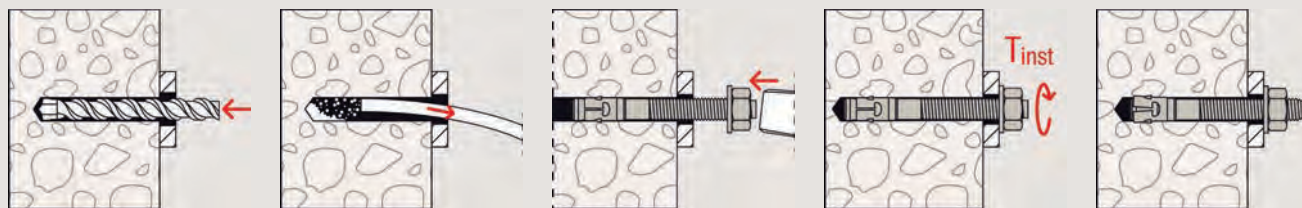

Technical data

4

Bolt anchor FXA



FXA

Item	Zinc-plated steel	Stainless steel	Approval ETA	Drill hole diameter d_0 [mm]	Min. drill hole depth for through fixings h_2 [mm]	Anchor length l [mm]	Width across nut SW [mm]	Sales unit [pcs]
	Item No. gvz	Item No. R						
FXA 8/5 x 66	523129	—	●	8	61	66	13	50
FXA 8/10 x 71	523131	523270	●	8	66	71	13	50
FXA 8/30 x 91	523132	523271	●	8	86	91	13	50
FXA 8/50 x 111	523222	523272	●	8	106	111	13	50
FXA 10/10 x 86	523133	523273	●	10	78	86	17	50
FXA 10/20 x 96	523134	523274	●	10	88	96	17	50
FXA 10/30 x 106	523223	—	●	10	98	106	17	50
FXA 10/50 x 126	523135	523276	●	10	118	126	17	20
FXA 10/100 x 176	523136	—	●	10	168	176	17	20
FXA 12/10 x 106	523137	523277	●	12	95	106	19	20
FXA 12/20 x 116	523138	523278	●	12	105	116	19	20
FXA 12/30 x 126	523139	—	●	12	115	126	19	20
FXA 12/50 x 146	523141	523304	●	12	135	146	19	20
FXA 12/100 x 196	523142	—	●	12	185	196	19	20
FXA 16/25 x 145	523143	523305	●	16	129	145	24	10
FXA 16/50 x 170	523144	523306	●	16	154	170	24	10
FXA 16/100 x 220	523145	—	●	16	204	220	24	10

Bolt anchor FWA

The cost-effective fixation without approval - for use in non-cracked concrete

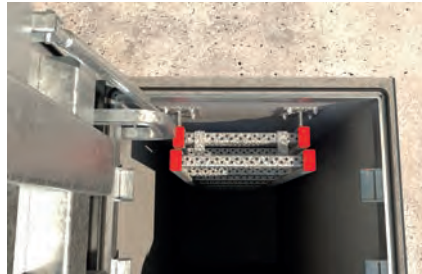

Stormwater overflow tank manholes



Column bases

4

Applications

- Steelwork constructions
- Guard rails
- Consoles
- Ladders
- Cable trays
- Machines
- Staircases
- Gates
- Façades

Advantages

- Fewer fixing points and smaller anchor plates due to the high load capacity of standard anchorage depth.
- High flexibility and time savings thanks

- reduced anchorage depth.
- Time saving due to push-through installation and reduced drill hole depth.
- Extensive assortment offers the use of imperial and metric dimensions.

Building materials

- Concrete C20/25, non-cracked

Versions

- Zinc-plated steel
- Hot-dip galvanised steel

Functioning

- The FWA is offered in zinc-plated steel for indoor use and sherardized steel for temporary outdoor use.
- The bolt anchor can be used with two anchorage depths.
- During the installation, the cone is pulled into the expansion sleeve. Thereby the sleeve expands against the drill hole wall.

Installation FWA

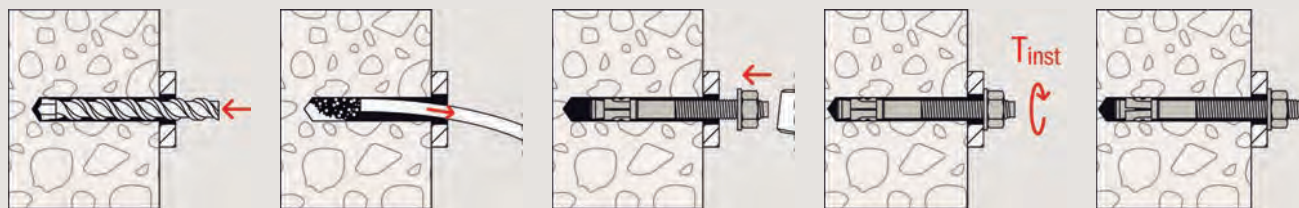

Technical data

Bolt anchor FWA (metric)



FWA (metric)

Item	Zinc-plated steel	Hot-dip galvanised steel	Drill hole diameter	Min. drill hole depth for through fixings	Anchor length	Max. fixture thickness	Thread	Width across nut	Sales unit
	Item No. gvz	Item No. hdg	d_0 [mm]	h_2 [mm]	l [mm]	t_{fix} [mm]	$\emptyset \times$ length [mm]	SW [mm]	[pcs]
FWA 6 x 45	045536	—	6	40	40	3	M 6	10	100
FWA 6 x 55	045582	—	6	55	55	15	M 6	10	100
FWA 6 x 70	045598	—	6	70	70	30	M 6	10	100
FWA 8 x 50	045644	—	8	50	50	5	M 6	13	50
FWA 8 x 60	502893	—	8	60	60	15	M 8	13	50
FWA 8 x 65	045788	502922	8	65	65	20	M 8	13	50
FWA 8 x 80	045789	502923	8	80	80	35	M 8	13	50
FWA 8 x 95	045790	502924	8	95	95	50	M 8	13	50
FWA 8 x 120	045791	502925	8	120	120	75	M 8	13	50
FWA 10 x 65	045645	—	10	65	65	10	M 10	17	50
FWA 10 x 80	045792	502926	10	80	80	25	M 10	17	50
FWA 10 x 95	045793	502927	10	95	95	40	M 10	17	50
FWA 10 x 115	045794	502928	10	115	115	60	M 10	17	25
FWA 10 x 130	045646	502929	10	130	130	75	M 10	17	25
FWA 10 x 140	503367	—	10	140	140	85	M 10	17	25
FWA 10 x 160	503368	—	10	160	160	105	M 10	17	25
FWA 10 x 180	503369	—	10	180	180	115	M 10	17	25
FWA 10 x 200	503370	—	10	200	200	135	M 10	17	25
FWA 12 x 80	045647	502972	12	80	80	10	M 12	19	25
FWA 12 x 100	045648	502973	12	100	100	30	M 12	19	25
FWA 12 x 120	045795	502974	12	120	120	50	M 12	19	25
FWA 12 x 150	045796	502975	12	150	150	80	M 12	19	25
FWA 12 x 160	503371	—	12	160	160	90	M 12	19	25
FWA 12 x 180	503372	—	12	180	180	110	M 12	19	25
FWA 12 x 200	503373	—	12	200	200	130	M 12	19	25
FWA 12 x 220	503374	—	12	220	220	150	M 12	19	25
FWA 12 x 240	503377	—	12	240	240	170	M 12	19	25
FWA 16 x 105	045649	502976	16	105	105	15	M 16	24	20
FWA 16 x 125	—	502977	16	125	125	35	M 16	24	20
FWA 16 x 125	502921	—	16	115	125	35	M 16	24	20
FWA 16 x 140	045798	502978	16	140	140	50	M 16	24	10
FWA 16 x 180	045799	502979	16	180	180	90	M 16	24	10
FWA 16 x 200	503379	—	16	190	200	110	M 16	24	10
FWA 20 x 120	—	502872	20	120	120	—	M 20	30	—
FWA 20 x 160	045800	502980	20	160	160	40	M 20	30	10
FWA 20 x 200	503382	—	20	190	200	80	M 20	30	10
FWA 20 x 220	056133	—	20	210	220	100	M 20	30	10
FWA 20 x 240	503383	—	20	230	240	120	M 20	30	10

Technical data

Bolt anchor FWA (imperial)



FWA (imperial)

Item	Item No. gvz	Drill diameter	Min. drill hole depth	Anchor length	Max. fixing thickness	Thread	Width across nut	Sales unit
		d ₀ [inch]	h ₁ [inch]	l [inch]	[inch]	[inch]	SW [inch]	[pcs]
FWA 1/4 x 1-3/4	048934	1/4	1 5/8	1 3/4	0	1/4	7/16	100
FWA 1/4 x 2-1/4	048936	1/4	2 1/8	2 1/4	3/8	1/4	7/16	100
FWA 1/4 x 3	048937	1/4	—	3	1	1/4	7/16	—
FWA 1/4 x 3-1/4	048938	1/4	3 1/8	3 1/4	1 1/4	1/4	7/16	100
FWA 5/16 x 2	048939	5/16	—	2	0	5/16	1/2	50
FWA 5/16 x 2-3/4	048940	5/16	2 5/8	2 3/4	5/8	5/16	1/2	50
FWA 5/16 x 3-1/2	048941	5/16	3 3/8	3 1/2	1 3/8	5/16	1/2	50
FWA 3/8 x 2-1/4	048944	3/8	2 1/8	2 1/4	1/8	3/8	9/16	50
FWA 3/8 x 2-3/4	048945	3/8	2 5/8	2 3/4	1/4	3/8	9/16	50
FWA 3/8 x 3	048946	3/8	2 7/8	3	1/2	3/8	9/16	50
FWA 3/8 x 3-1/2	048947	3/8	3 3/8	3 1/2	1	3/8	9/16	50
FWA 3/8 x 3-3/4	048948	3/8	3 5/8	3 3/4	1 1/4	3/8	9/16	50
FWA 3/8 x 4-1/2	048949	3/8	4 3/8	4 1/2	2	3/8	9/16	20
FWA 3/8 x 5	048950	3/8	4 7/8	5	2 1/2	3/8	9/16	20
FWA 1/2 x 2-3/4	048988	1/2	2 5/8	2 3/4	1/4	1/2	3/4	20
FWA 1/2 x 3-3/4	048992	1/2	3 5/8	3 3/4	1/2	1/2	3/4	20
FWA 1/2 x 4	048993	1/2	3 7/8	4	3/4	1/2	3/4	20
FWA 1/2 x 4-1/4	048995	1/2	4 3/8	4 1/4	1	1/2	3/4	20
FWA 1/2 x 5-1/2	048996	1/2	5 3/8	5 1/2	2 1/4	1/2	3/4	20
FWA 1/2 x 7	049013	1/2	6 7/8	7	3 3/4	1/2	3/4	20
FWA 5/8 x 3-1/2	049022	5/8	3 3/8	3 1/2	1/4	5/8	15/16	10
FWA 5/8 x 4-1/2	049025	5/8	4 3/8	4 1/2	1	5/8	15/16	10
FWA 5/8 x 5	049026	5/8	4 7/8	5	1	5/8	15/16	10
FWA 5/8 x 6	049031	5/8	5 7/8	6	2 1/8	5/8	15/16	10
FWA 5/8 x 7	049043	5/8	6 7/8	7	3 1/8	5/8	15/16	10
FWA 5/8 x 8-1/2	049080	5/8	8 3/8	8 1/2	4 1/2	5/8	15/16	10
FWA 3/4 x 4-1/4	049084	3/4	4 3/8	4 1/4	1/4	3/4	1 1/8	10
FWA 3/4 x 4-3/4	049085	3/4	4 5/8	4 3/4	1/4	3/4	1 1/8	10
FWA 3/4 x 5-1/2	049086	3/4	5 3/8	5 1/2	1	3/4	1 1/8	10
FWA 3/4 x 6-1/4	049087	3/4	6 3/8	6 1/4	1 3/4	3/4	1 1/8	10
FWA 3/4 x 7	049088	3/4	6 7/8	7	2 1/2	3/4	1 1/8	5
FWA 3/4 x 8-1/2	049089	3/4	8 3/8	8 1/2	4	3/4	1 1/8	5
FWA 3/4 x 10	049095	3/4	9 7/8	10	5 1/2	3/4	1 1/8	5
FWA 1 x 6	049120	1	5 7/8	6	0	1	1 1/2	5
FWA 1 x 9	049122	1	8 7/8	9	3	1	1 1/2	5

Loads

Wedge Anchor FWA

Recommended loads of a single anchor¹⁾ in normal concrete of strength class C20/25.

Type	Material / surface ³⁾	Effective anchorage depth $h_{ef \geq}$ [mm]	Minimum member thickness h_{min} [mm]	Drill hole diameter d_0 [mm]	Drill hole diameter in fixture ²⁾ d_f [mm]	Installation torque T_{inst} [Nm]	Non-cracked concrete			
							Recommended tension (N_{rec}), shear loads (V_{rec}), minimum spacing (s_{min}) and edge distances (c_{min})			
							$N_{rec}^{3)}$ [kN]	$V_{rec}^{3)}$ [kN]	$s_{min}^{3)}$ [mm]	$c_{min}^{3)}$ [mm]
FWA 6	gvz	25	100	6	8	4	1.3	1.3	80	40
	gvz	30	100	6	8	4	2.1	1.7	100	50
FWA 8	gvz / shrd	25	100	8	10	10	1.4	1.4	80	40
	gvz / shrd	35	100	8	10	10	2.8	2.8	90	45
FWA 10	gvz / shrd	25	100	10	13	25	1.8	1.8	90	45
	gvz / shrd	35	100	10	13	25	2.8	2.8	120	60
	gvz / shrd	45	100	10	13	25	3.8	3.8	150	75
FWA 12	gvz / shrd	35	100	12	15	40	3.2	3.2	120	60
	gvz / shrd	45	100	12	15	40	4.4	4.4	150	75
	gvz / shrd	55	110	12	15	40	5.8	5.8	180	90
FWA 16	shrd	45	100	16	19	100	4.4	4.4	150	75
	gvz	50	100	16	19	100	4.4	4.4	150	75
	shrd	60	120	16	19	100	6.2	6.2	200	100
	gvz	65	130	16	19	100	6.2	6.2	200	100
	shrd	75	150	16	19	100	8.5	8.5	240	120
	gvz	80	160	16	19	100	8.5	8.5	240	120
FWA 20	shrd	70	150	20	23	200	8.0	-	210	105
	gvz / shrd	75	150	20	23	200	9.7	9.7	240	120
	gvz / shrd	95	190	20	23	200	13.5	13.5	300	150
FWA 24	gvz	95	190	24	28	260	15.0	-	300	150
	gvz	120	240	24	28	260	16.0	-	360	180

¹⁾ The partial safety factors for material resistance as well as a partial safety factor for load actions of $\gamma_L = 1.4$ are considered. As a single anchor counts e.g. an anchor with a spacing $s \geq 3 \times h_{ef}$ and an edge distance $c \geq 1.5 \times h_{ef}$.

²⁾ For push-through installation.

³⁾ As recommended loads are given in the table, combinations of tensile and shear loads, bending moments and reduced edge and axial spacings (anchor groups) can not be carried out.

Loads

Wedge Anchor FWA

Recommended loads of a single anchor¹⁾ in normal concrete of strength class 3000 Psi.

Type	Material / surface ³⁾	Effective anchorage depth $h_{ef \geq}$ [in]	Minimum member thickness h_{min} [in]	Drill hole diameter d_0 [in]	Drill hole diameter in fixture ²⁾ d_f [in]	Installation torque T_{inst} [lbf-ft]	Non-cracked concrete			
							Recommended tension (N_{rec}), shear loads (V_{rec}), minimum spacing (s_{min}) and edge distances (c_{min})			
							$N_{rec}^{3)}$ [lb]	$V_{rec}^{3)}$ [lb]	$s_{min}^{3)}$ [in]	$c_{min}^{3)}$ [in]
FWA 1/4	gvz	1	4	1/4	3/8	3	202	-	3	1 1/2
	gvz	1 1/8	4	1/4	3/8	3	540	315	3 1/2	1 3/4
FWA 5/16	gvz	1 1/4	4	5/16	7/16	7	719	427	3 3/4	1 7/8
FWA 3/8	gvz	1 1/8	4	3/8	1/2	19	472	-	3 1/2	1 3/4
	gvz	1 5/16	4	3/8	1/2	19	944	562	4	2
FWA 1/2	gvz	1 3/8	4	1/2	5/8	30	764	-	4 1/8	2 1/8
	gvz	1 7/8	4	1/2	5/8	30	1461	854	5 3/4	2 7/8
FWA 5/8	gvz	2	4	5/8	7/8	74	1124	-	6	3 1/8
	gvz	2 3/8	4 3/4	5/8	7/8	74	2158	1281	7 1/8	3 5/8
FWA 3/4	gvz	2 1/2	5	3/4	1	148	2428	-	7 5/8	3 7/8
	gvz	2 3/4	5 1/2	3/4	1	148	3147	1866	8 1/4	4 1/8
FWA 1"	gvz	3 3/4	7 1/2	1	1 1/4	192	4406	-	11 1/4	5 5/8
	gvz	3 7/8	7 3/4	1	1 1/4	192	4676	-	11 5/8	5 7/8

¹⁾ The partial safety factors for material resistance as well as a partial safety factor for load actions of $\gamma_L = 1.4$ are considered. As a single anchor counts e.g. an anchor with a spacing $s \geq 3 \times h_{ef}$ and an edge distance $c \geq 1.5 \times h_{ef}$.

²⁾ For push-through installation.

³⁾ As recommended loads are given in the table, combinations of tensile and shear loads, bending moments and reduced edge and axial spacings (anchor groups) can not be carried out.

Heavy-duty anchor TA M

The installation-friendly internally threaded anchor for fixings in non-cracked concrete



Fall protection devices



Plant construction

4

Applications

- Steel constructions
- Handrails
- Consoles
- Ladders
- Cable trays
- Machines
- Staircases
- Gates
- Façades
- Stand-off installations

Certificates



ETA-04/0003, for non-cracked concrete

Advantages

- The optimised geometry minimises setting energy and allows for use in extremely narrow spaces. This allows for user-friendly installation.
- The three-part expansion sleeve creates even load distribution, thus allowing small edge and axial spacing. Thus the TA M is

extremely flexible.

- The metric internal thread allows to use standard screws or threaded rods for the ideal adaptation to suit the intended use.
- The red plastic cap protects against soiling and thus ensures free-running of the thread.

Building materials

Approved for:

- Concrete C20/25 to C50/60, non-cracked

Also suitable for:

- Concrete C12/15
- Natural stone with dense structure

Versions

- Zinc-plated steel

Functioning

- The TAM is suitable for pre-positioned installation.
- When applying the torque, the cone is pulled into the expansion sleeve and expands it against the drill hole wall.
- For correct installation, it must be ensured that the pre-positioned anchor TA M can be supported on the attachment, or that the threaded rod is countered.
- Determining the screw length l_s :
Screw length l_s =
Length of fixing
+ Thickness of fixture t_{fix}
+ Thickness of washer.

Installation TA M

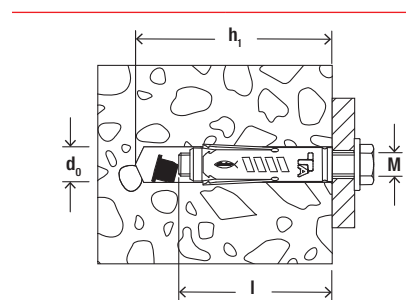
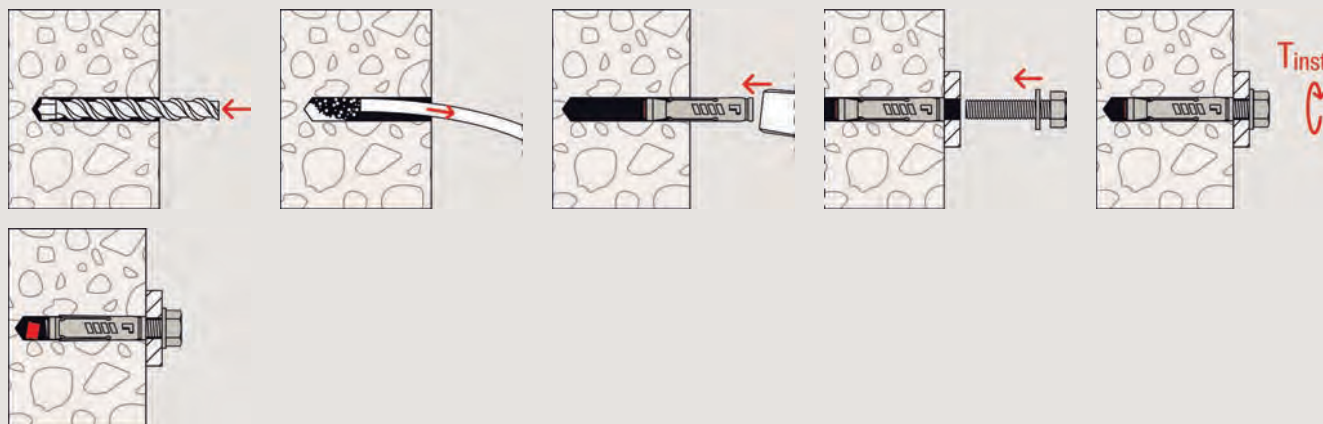

Technical data

Heavy-duty anchor TA M



TA M

Item	Zinc-plated steel	Approval ETA	Drill hole diameter	Min. drill hole depth	Anchor length	Thread M	Sales unit
	Item No.		d_0 [mm]	h_1 [mm]	l [mm]		[pcs]
TA M6	090245	●	10	65	49	M 6	50
TA M8	090246	●	12	70	56	M 8	50
TA M10	090247	●	15	90	69	M 10	25
TA M12	090248	●	18	105	86	M 12	25

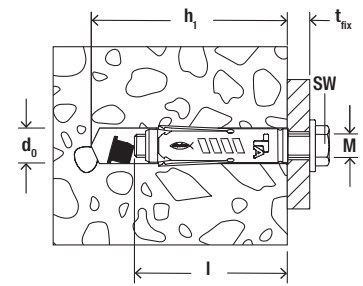

Technical data

Heavy-duty anchor TA M-S



TA M-S with screw

Item	Zinc-plated steel	Approval	Drill hole diameter d_0 [mm]	Min. drill hole depth h_1 [mm]	Anchor length l [mm]	Max. fixture thickness t_{fix} [mm]	Screw $\varnothing \times$ length	Width across nut SW [mm]	Sales unit [pcs]
	Item No.								
TA M6 S/10	090249	●	10	65	49	10	M 6 x 60	10	50
TA M8 S/10	090250	●	12	70	56	10	M 8 x 65	13	50
TA M10 S/20	090251	●	15	90	69	20	M 10 x 90	17	25
TA M12 S/25	090252	●	18	105	86	25	M 12 x 110	19	20

4

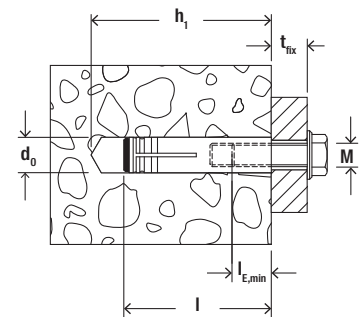

Technical data

Heavy-duty anchor SL M



SL M

Item	Item No.	Drill hole diameter	Min. drill hole depth	Anchor length	Internal thread	Min. bolt penetration	Sales unit [pcs]
		d_0 [mm]	h_1 [mm]	l [mm]	A1	$l_{E,min}$ [mm]	
SL M 16	050556	24	110	90	M 16	90	10
SL M 20	050557	30	130	110	M 20	110	5
SL M 24	050558	35	150	125	M 24	125	5

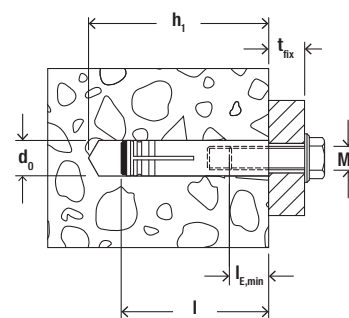

Technical data

Heavy-duty anchor SL M-N



SL M-N R

Item	Item No.	Drill hole diameter d_0 [mm]	Min. drill hole depth h_1 [mm]	Anchor length l [mm]	Internal thread A1	Min. bolt penetration $l_{E,min}$ [mm]	Sales unit [pcs]
SL M 8 N R	050526	12	60	54	M 8	52	25
SL M 10 N R	050527	16	70	62	M 10	62	20

Loads

Heavy-duty anchor TA M

Permissible loads of a single anchor¹⁾ in normal concrete of strength class C20/25.

For the design the complete current assessment ETA-04/0003 has to be considered.

Type	Material/ surface ²⁾	Screw material	Effective anchorage depth h_{ef} [mm]	Minimum member thickness h_{min} [mm]	Installation torque T_{inst} [Nm]	Non-cracked concrete			
						Permissible tension (N_{perm}) and shear loads (V_{perm}); minimum spacing (s_{min}) and edge distances (c_{min}) with reduced loads			
						$N_{perm}^{3)}$ [kN]	$V_{perm}^{3)}$ [kN]	$s_{min}^{3)}$ [mm]	$c_{min}^{3)}$ [mm]
TA M6	gvz	8.8	40	100	10	3.6	3.3	80	50
TA M8	gvz	8.8	45	100	20	5.7	6.7	90	60
TA M10	gvz	8.8	55	110	40	9.5	11.0	110	70
TA M12	gvz	8.8	70	140	75	11.9	17.0	160	120

¹⁾ Design according to EN 1992-4:2018 (for static resp. quasi-static loads). The partial safety factors for material resistance as regulated in the ETA as well as a partial safety factor for load actions of $\gamma_L = 1.4$ are considered. As a single anchor counts e.g. an anchor with a spacing $s \geq 3 \times h_{ef}$ and an edge distance $c \geq 1.5 \times h_{ef}$. Accurate data see ETA.

²⁾ For technical data on steel grade and variants, see ETA.

³⁾ In the case of combinations of tension and shear loads, bending moments with reduced or minimum spacing and edge distances (anchor groups), the design must be carried out in accordance with the provisions of the complete ETA and the provisions of the EN 1992-4:2018. We recommend using our anchor design software C-FIX.

Heavy-duty anchor TA M-T

The installation-friendly push-through anchor for fixings in non-cracked concrete

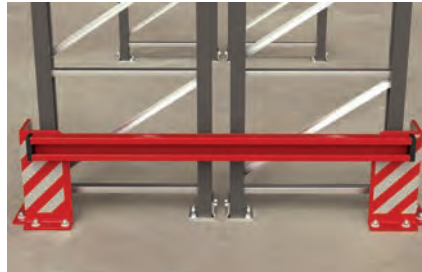

Collision protection



Benches

4

Applications

- Steel constructions
- Handrails
- Consoles
- Ladders
- Cable trays
- Machines
- Staircases
- Gates
- Façades

Certificates



ETA-04/0003, for non-cracked concrete

Advantages

- The optimised geometry minimises setting energy and allows for use in extremely narrow spaces. This allows for user-friendly installation.
- The three-part expansion sleeve creates even load distribution, thus allowing small edge and axial spacing. Thus the TA M-T

is extremely flexible.

- The TA M-BP version with twist-off head hinders the dismantling of the fixture for use as a theft-deterrent and break-in protection.
- The detachable screw connection allows for surface flush removal.

Building materials

Approved for:

- Concrete C20/25 to C50/60, non-cracked

Also suitable for:

- Concrete C12/15
- Natural stone with dense structure

Versions

- Zinc-plated steel

Functioning

- The TA M-T is suitable for push-through installation.
- When applying the torque, the cone is pulled into the expansion sleeve and expands it against the drill hole wall.
- The hexagonal head of the TA M-BP is tightened until it breaks off.

Installation TA M-T

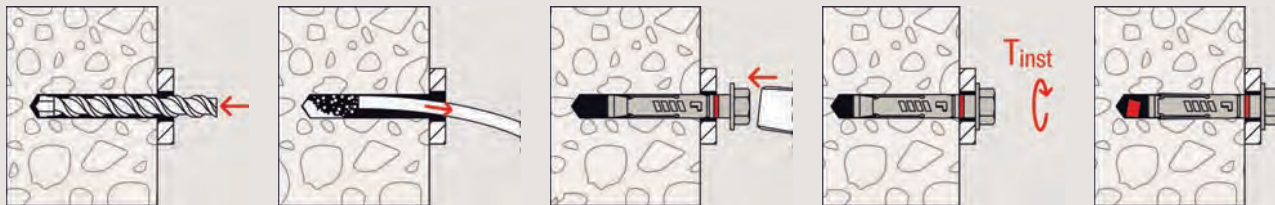

4

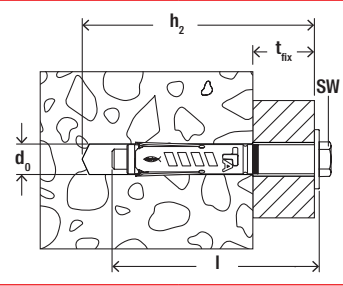

Technical data

Heavy-duty anchor TA M-T



TA M-T for push-through installation

Item	Zinc-plated steel	Approval	Drill hole diameter	Min. drill hole depth for through fixings	Anchor length	Max. fixture thickness	Thread	Width across nut	Sales unit
	Item No.	ETA	d_0 [mm]	h_2 [mm]	l [mm]	t_{fix} [mm]	M	SW [mm]	[pcs]
TA M8 T/25 S	090268	●	12	95	84	25	M 8	13	50
TA M10 T/25 S	090269	●	15	110	100	25	M 10	17	25
TA M12 T/25 S	090270	●	18	120	114	25	M 12	19	20

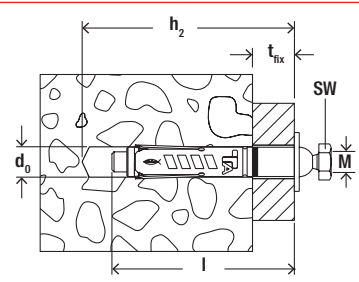

Technical data

Heavy-duty anchor TA M-T BP



TA M-T BP with twist-off head

Item	Item No.	Drill hole diameter	Min. drill hole depth for through fixings	Anchor length	Max. fixture thickness	Thread	Width across nut	Sales unit
		d_0 [mm]	h_2 [mm]	l [mm]	t_{fix} [mm]	M	SW [mm]	[pcs]
TA M8 BP	090265	12	95	84	25	M 8	13	50

Loads

Heavy-duty anchor TA M-T

Permissible loads of a single anchor¹⁾ in normal concrete of strength class C20/25.
For the design the complete current assessmentt ETA-04/0003 has to be considered.

Type	Material/ surface ²⁾	Screw material	Effective anchorage depth h_{ef} [mm]	Minimum member thickness h_{min} [mm]	Installation torque T_{inst} [Nm]	Non-cracked concrete			
						Permissible tension (N_{perm}) and shear loads (V_{perm}); minimum spacing (s_{min}) and edge distances (c_{min}) with reduced loads			
						$N_{perm}^{3)}$ [kN]	$V_{perm}^{3)}$ [kN]	$s_{min}^{3)}$ [mm]	$c_{min}^{3)}$ [mm]
TA M8 T	gvz	8.8	45	100	20	5.7	6.7	90	60
TA M10 T	gvz	8.8	55	110	40	9.5	11.0	110	70
TA M12 T	gvz	8.8	70	140	75	11.9	17.0	160	120

¹⁾ Design according to EN 1992-4:2018 (for static resp. quasi-static loads). The partial safety factors for material resistance as regulated in the ETA as well as a partial safety factor for load actions of $\gamma_L = 1.4$ are considered. As a single anchor counts e.g. an anchor with a spacing $s \geq 3 \times h_{ef}$ and an edge distance $c \geq 1.5 \times h_{ef}$. Accurate data see ETA.

²⁾ For technical data on steel grade and variants, see ETA.

³⁾ In the case of combinations of tension and shear loads, bending moments with reduced or minimum spacing and edge distances (anchor groups), the design must be carried out in accordance with the provisions of the complete ETA and the provisions of the EN 1992-4:2018. We recommend using our anchor design software C-FIX.

Sleeve anchor FSA

The push-through anchor for structural fixings in non-cracked concrete

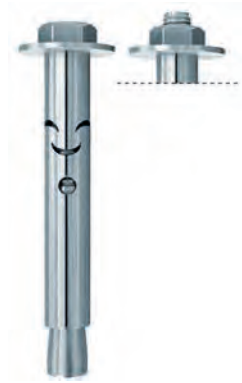

4



Bicycle racks



Waste bins

Applications

- Handrails
- Consoles
- Ladders
- Cable trays
- Gates
- Façades
- Temporary or structural fixings

Advantages

- The optimised geometry minimises setting energy and enables the use in extremely narrow spaces. This allows for user-friendly installation.
- The anchor design makes it possible to

- use different head shapes for flexible design solutions: Hexagon head (type S), bolt version with nut and washer (type B).
- The detachable screw connection allows for surface flush removal.

Building materials

- Suitable for:
- Concrete C12/15 to C20/25, non-cracked
 - Natural stone with dense structure

Versions

- Zinc-plated steel

Functioning

- The FSA is suitable for push-through installation.
- When applying the torque, the cone is pulled into the expansion sleeve and expands it against the drill hole wall.
- The half-moon shaped recesses act as a crumple zone to take the torque slip-page, so that the attachment is pulled onto the anchor base.

Installation FSA

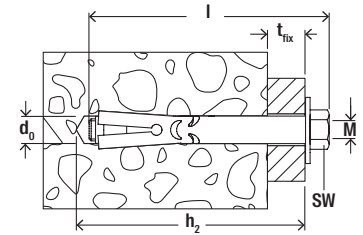
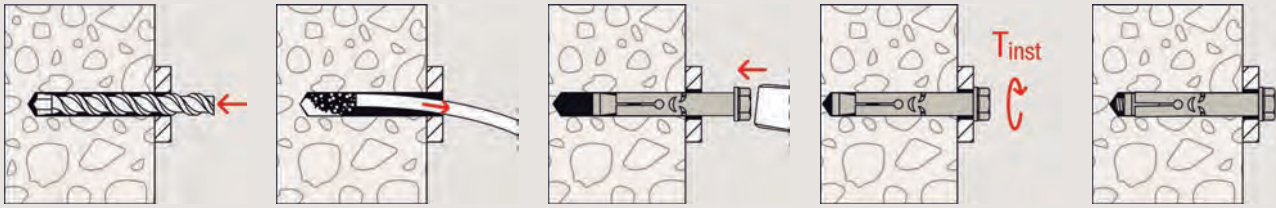

4

Technical data

Sleeve anchor FSA-S



FSA-S

Item	Item No.	Drill hole diameter	Min. drill hole depth for through fixings	Max. fixture thickness	Anchor length	Thread	Width across nut	Sales unit
		d_0 [mm]	h_2 [mm]	t_{fix} [mm]	l [mm]	M	SW [mm]	[pcs]
FSA 8/15 S	068520	8	65	15	64	M 6	10	50
FSA 8/40 S	068521	8	90	40	89	M 6	10	50
FSA 8/65 S	068522	8	115	65	114	M 6	10	50
FSA 10/10 S	068523	10	65	10	65	M 8	13	20
FSA 10/35 S	068524	10	90	35	90	M 8	13	20
FSA 10/60 S	068525	10	115	60	115	M 8	13	20
FSA 12/10 S	068526	12	75	10	76	M 10	17	20
FSA 12/25 S	068527	12	90	25	91	M 10	17	20
FSA 12/50 S	068528	12	115	50	116	M 10	17	20

Technical data

Sleeve anchor FSA-B



FSA-B

Item	Item No.	Drill hole diameter	Min. drill hole depth for through fixings	Max. fixture thickness	Anchor length	Thread	Width across nut	Sales unit
		d_0 [mm]	h_2 [mm]	t_{fix} [mm]	l [mm]	M	SW [mm]	[pcs]
FSA 8/15 B	068500	8	65	15	65	M 6	10	50
FSA 8/40 B	068501	8	90	40	90	M 6	10	50
FSA 8/65 B	068502	8	115	65	115	M 6	10	50
FSA 10/10 B	068503	10	65	10	69	M 8	13	20
FSA 10/35 B	068504	10	90	35	94	M 8	13	20
FSA 10/60 B	068505	10	115	60	119	M 8	13	20
FSA 12/10 B	068506	12	75	10	81	M 10	17	20

Technical data

Sleeve anchor FSA-B



FSA-B

	Item No.	Drill hole diameter d_0 [mm]	Min. drill hole depth for through fixings h_2 [mm]	Max. fixture thickness t_{fix} [mm]	Anchor length l [mm]	Thread M	Width across nut SW [mm]	Sales unit [pcs]
Item								
FSA 12/25 B	068507	12	90	25	96	M 10	17	20
FSA 12/50 B	068508	12	115	50	121	M 10	17	20
FSA 12/75 B	068509	12	140	75	146	M 10	17	20

Loads

Sleeve anchor FSA

Recommended loads¹⁾ of a single anchor in normal concrete of strength class C20/25.

Type	Material/ surface	Effective anchorage depth h_{ef} [mm]	Minimum member thickness h_{min} [mm]	Installation torque T_{inst} [Nm]	Char. spacing $s_{cr,N}$ [mm]	Char. edge distance $c_{cr,N}$ [mm]	Non-cracked concrete			
							Recommended tension (N_{rec}) and shear loads (V_{rec}); minimum spacing (s_{min}) and edge distances (c_{min}) with reduced loads			
							$N_{rec}^{2)}$ [kN]	$V_{rec}^{2)}$ [kN]	$s_{min}^{3)}$ [mm]	$c_{min}^{3)}$ [mm]
FSA 8	gvz	35	70	8	105	53	2.0	3.4	70	50
FSA 10	gvz	40	80	25	120	60	3.5	6.3	80	60 ⁴⁾
FSA 12	gvz	50	100	40	150	75	5.0	9.9	100	75 ⁴⁾

¹⁾ Required safety factors are considered. As a single anchor counts e.g. an anchor with a spacing $s \geq 3 \times h_{ef}$ and an edge distance $c \geq 1.5 \times h_{ef}$.

²⁾ In the case of combinations of tension and shear loads, bending moments with reduced or minimum spacing and edge distances (anchor groups), the design must be carried out in accordance the provisions of the EN 1992-4:2018.

³⁾ Minimum possible axial spacings resp. edge distance while reducing the recommended load.

⁴⁾ No reduction of the recommended tensile load.

Fixing set for diamond drills FDBB

The reusable fixing system for diamond drills and saws



Applications

- Diamond and core drilling devices
- Diamond saws

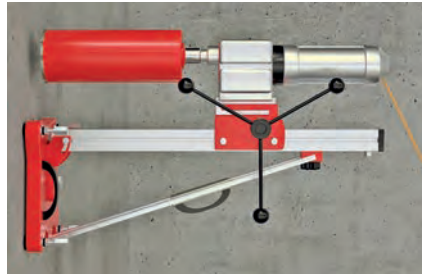

Diamond drills



Detail: Diamond drills

Advantages

- The detachable screw connection between the expansion element and spindle enables simple dismantling and ensures that the spindle bolt can be reused.
- The robust, reusable spindle bolt guarantees a long life span.
- The active principle of the anchor bolt

enables an active controlled expansion, thus offering a high level of safety.

- The large steel cross-section provides high shear load-bearing capability and, as such, high security for the jerky stoppage of the drill bit.

Building materials

Suitable for:

- Concrete C12/15 to C50/60, non-cracked
- Natural stone with dense structure

Versions

- Zinc-plated steel

Functioning

- The FDBB is suitable for pre-positioned and push-through installation.
- An expansion element must be added to the spindle bolt before installation.
- Use a hammer to drive the FDBB through the base plate of the drilling device into the drill hole.
- When the nut is tightened, the cone bolt is pulled into the expansion clip and expands it against the drill hole wall.
- The expansion element remains in the drill hole when dismantling the spindle bolt. The spindle bolt is once again completed with an expansion element and can be reused.

Installation FDBB

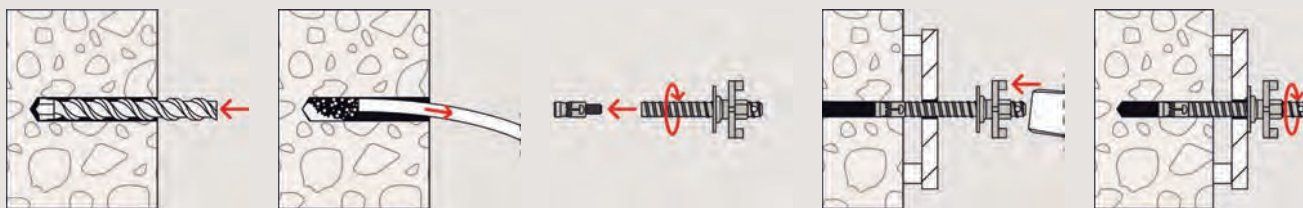

Deinstallation

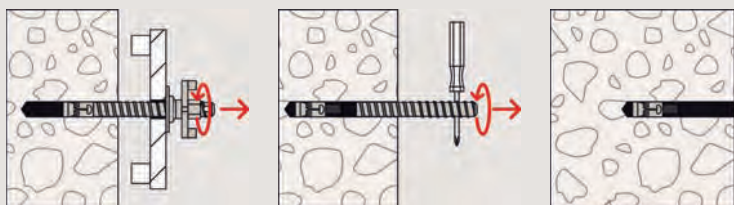

4

Technical data

Fixing set for diamond drills FDBB



FDBB

FDBB SE

Item	Item No.	Drill hole diameter	Usable length	Min. drill hole depth for through fixings	Width across nut	Length	Contents	Sales unit
		d_0 [mm]	t_{fix} [mm]	h_2 [mm]	SW [mm]	L [mm]		[pcs]
FDBB 16/50 Set	090680	16	50	135	27	200	1 expansion element 16 SE, 1 spindle bolt 16/50/160, 1 washer, 1 nut	1
FDBB 16/250 Set	554060	16	250	135	27	400	1 expansion element 16 SE, 1 spindle bolt 16, 1 washer, 1 nut	1
FDBB 16 SE	090681	16	—	—	—	—	Expansion element	25

Loads

Fixing set for Diamond Drills FDBB

Recommended loads¹⁾ for a single anchor in normal concrete of strength class C12/15 and C20/25.

Type	Recommended bending moment M_{empf} [Nm]	Non-cracked concrete C12/15				C20/25	
		Recommended tension (N_{rec}) and shear loads (V_{rec})				N_{rec} [mm]	V_{rec} ²⁾ [mm]
		N_{rec} [kN]	V_{rec} ²⁾ [kN]				
FDBB	98.0	9.0	13.3		12.0		13.3

¹⁾ Required safety factors are considered.

²⁾ Only steel failure is considered.

Wall screw MR

The fixing with simple hammerset installation in non-cracked concrete



Radiators

Applications

- Non-approval-relevant fixings only
- Handrails
- Gratings
- Garden gates

Advantages

- The special construction of the anchor sleeve enables it to be set into the drill hole with a low number of hammer blows. This enables easy installation.
- The flush-sunk expansion pin signifies the complete expansion of the anchor,

and thereby ensures minimum movement when under load.

- The special geometry of the expansion pin reduces the setting energy, thereby enabling a fast and energy-saving installation.

Building materials

Suitable for:

- Concrete C12/15 to C50/60, non-cracked
- Natural stone with dense structure

Functioning

- The MR is suitable for pre-positioned and push-through installation.
- The anchor sleeve is driven into the drill hole with a hammer, without the need for an expansion pin.
- Then the expansion pin is driven in with a hammer, and the wall screw expands against the drill hole wall.

Versions

- Zinc-plated steel

Installation MR

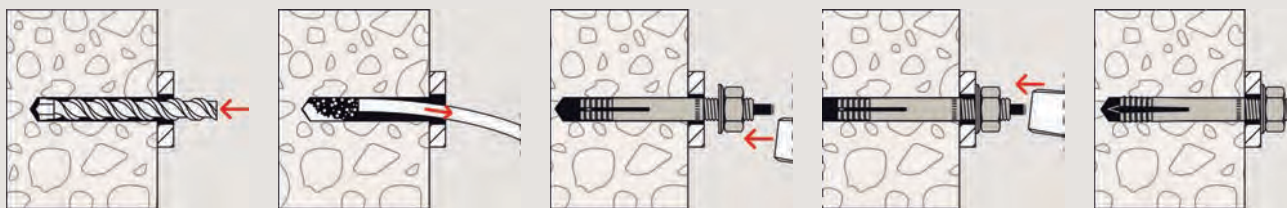

4

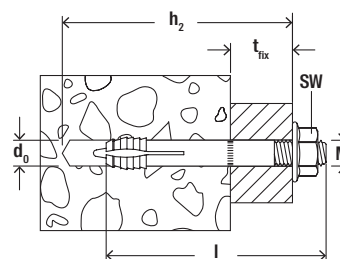

Technical data

Wall screw MR



MR

Item	Item No.	Drill hole diameter	Anchor length	Min. drill hole depth for through fixings	Thread	Width across nut	Max. fixture thickness	Sales unit
		d_0 [mm]	l [mm]	h_2 [mm]	M	SW [mm]	t_{fix} [mm]	[pcs]
MR 8	050583	8	70	70	M 8	13	22	25
MR 10	050584	10	85	85	M 10	15	24	20
MR 12	050585	12	100	100	M 12	18	27	10

Hollow-ceiling anchor FHY

The installation-friendly internally threaded anchor for fixings in pre-stressed hollow-core concrete slabs



Air conditioning units in pre-stressed hollow-core concrete slabs



Cable trays in pre-stressed hollow-core concrete

4

Applications

- Pipelines
- Cable trays
- Ventilation systems
- Sprinkler systems
- Suspended ceilings
- Consoles
- Steel constructions
- Timber constructions

Advantages

- The active principle of the anchor means that the FHY can be used in cavities or in solid materials up to 5 cm from the tensioning wire. This ensures the highest flexibility and user-friendly installation.
- The embossed edge prevents the anchor sleeve from slipping in the cavity, thus allowing for trouble-free installation.
- The optimised geometry minimises

- setting energy and allows for use in extremely narrow spaces. This allows for user-friendly installation.
- The metric internal thread means that it is possible to use standard screws or threaded rods for the ideal adaptation to suit the intended use.
- External report for the usage of the FHY in seismic conditions.

Certificates



Fire resistance classification
R120



INOX STAINLESS STEEL



from M8

Building materials

Approved for:

- Pre-stressed hollow-core concrete slabs $\geq C45/55$

Versions

- Zinc-plated steel
- Stainless steel R

Functioning

- The FHY is suitable for pre-positioned installation.
- Position the FHY hollow-ceiling anchor in the drill hole and drive in flush to the surface of the anchor base using the hammer.
- The FHY pre-positioned anchor must be able to be supported on the attachment for expansion.
- When applying the torque, the cone is pulled into the expansion sleeve and expands it into the cavity or expands it in the solid material against the drill hole wall.
- Screw length $l_s =$
 Minimum screw-in depth e_2
 + Thickness of fixture t_{fix}
 + Thickness of washer
 (with threaded rod: + height of nut)

Installation FHY

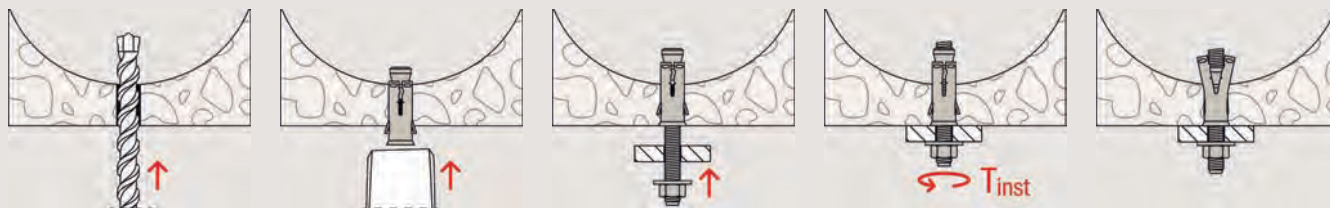

4

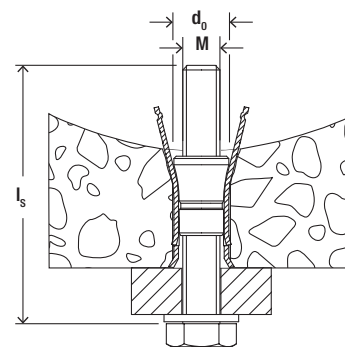

Technical data

Hollow-ceiling anchor FHY



FHY

Item	Zinc-plated steel Item No. gvz	Stainless steel Item No. R	Approval ETA	Drill hole diameter d_0 [mm]	Anchor length l [mm]	Thread M	Min. drill hole depth h_1 [mm]	Min. bolt penetration $l_{E,min}$ [mm]	Sales unit [pcs]
FHY M 6	030138	—	●	10	37	M 6	50	37	50
FHY M 6	—	030139	—	10	37	M 6	50	37	50
FHY M 8	030146	—	●	12	43	M 8	60	43	25
FHY M 8	—	030147	—	12	43	M 8	60	43	25
FHY M10	030148	—	●	16	52	M 10	65	52	20
FHY M10	—	030151	—	16	52	M 10	65	52	20
FHY M12	545512	—	—	18	52	M 12	65	52	25

Loads

Hollow-ceiling anchor FHY

Permissible loads¹⁾ of a single anchor in pre-stressed hollow-core concrete slabs of strength class $\geq C45/55$.
For the design the complete current approval Z-21.1-1711 has to be considered.

Type	Material/surface	Screw material ²⁾	Bottom flange thickness d_b [mm]	Installation torque T_{inst} [Nm]	Required edge distance (with one edge) for max. load C_{cr} [mm]	Pre-stressed hollow-core slab		
						Permissible load (F_{perm}); minimum spacing (s_{min}) and edge distances (c_{min}) with reduced loads	F_{perm} ³⁾ [kN]	s_{min} ⁴⁾ [mm]
FH Y M6	gvz	4.6	25 - 29	10	150	0.7	70	100
	gvz	4.6	30 - 39	10	150	0.9	80	100
	gvz	4.6	≥ 40	10	150	2.0	100	100
FH Y M8	gvz	4.6	25 - 29	10	150	0.7	70	100
	gvz	4.6	30 - 39	10	150	0.9	80	100
	gvz	4.6	≥ 40	10	150	2.0	100	100
FH Y M10	gvz	4.6	30 - 39	20	150	1.2	80	100
	gvz	4.6	≥ 40	20	150	3.0	100	100

¹⁾ The required partial safety factors for material resistance as well as a partial safety factor for load actions of $\gamma_L = 1,4$ are considered.

²⁾ Further steel grades, versions and technical data see approval.

³⁾ Maximum load for char. spacing and edge distances. Valid for tensile load, shear load and oblique load under any angle. In the case of shear loads with lever arm (bending) as well as reduced/minimum spacing or edge distances (anchor groups), the design must be carried out in accordance with the provisions of the complete approval.

⁴⁾ Minimum possible axial spacings resp. edge distance while reducing the permissible load.

Loads

Hollow-ceiling anchor FH Y stainless steel R

Recommended loads¹⁾ of a single anchor in pre-stressed hollow-core concrete slabs of strength class $\geq C45/55$.

Type	Material/surface	Screw material	Bottom flange thickness d_b [mm]	Installation torque T_{inst} [Nm]	Required edge distance (with one edge) for max. load C_{cr} [mm]	Pre-stressed hollow-core slab		
						Recommended tension (N_{rec}) and shear loads (V_{rec}); minimum spacing (s_{min}) and edge distances (c_{min}) with reduced loads	F_{rec} ²⁾ [kN]	s_{min} ³⁾ [mm]
FH Y M6 R	R	A4 - 50	25 - 29	10	150	0.7	70	100
	R	A4 - 50	30 - 39	10	150	0.9	80	100
	R	A4 - 50	≥ 40	10	150	2.0	100	100
FH Y M8 R	R	A4 - 50	25 - 29	10	150	0.7	70	100
	R	A4 - 50	30 - 39	10	150	0.9	80	100
	R	A4 - 50	≥ 40	10	150	2.0	100	100
FH Y M10 R	R	A4 - 50	30 - 39	20	150	1.2	80	100
	R	A4 - 50	≥ 40	20	150	3.0	100	100

¹⁾ Required safety factors are considered.

²⁾ Maximum load for char. spacing and edge distances. Valid for tensile load, shear load and oblique load under any angle.

³⁾ Minimum possible axial spacings resp. edge distance while reducing the recommended load.

Aircrete anchor FPX-I

The strong internally threaded anchor with unique 4-way expansion for fixings in aerated concrete

4

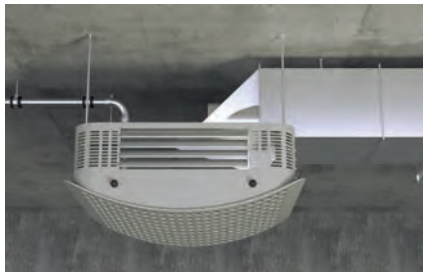

Air conditioning units



Rail fixing

Applications

- Suspended ceilings
- Cable trays
- Pipelines
- Ventilation ducts
- Guard rails/hand rails
- TV consoles
- Kitchen cupboards
- Stand-off installations

Advantages

- The FPX-I enables easy tightening via the hexagon wrench using a cordless screwdriver or ratchet and therefore offers top installation comfort.
- The deformation-controlled expansion of the anchor with the hexagon wrench ensures safe, even and gentle installation.
- The unique 4-way expansion of the FPX-I with a square expansion sleeve prevents the rotation of the anchor in the drill hole

- and ensures high tension and shear loads, which means fewer fixing points.
- The releasing of the hexagonal wrench guarantees an automatic setting control for each installation process.
- The first steel anchor with an ETA-Approval and fire protection certificate for fixings in aerated concrete enables use for safety-relevant fixings, too.

Certificates



ETA-12/0456, for autoclaved aerated concrete



Fire resistance classification R120



M8 - M12

Building materials

Approved for:

- Aerated concrete with compressive strength 2 to 7 N/mm²
- Aerated concrete wall or ceiling boards with compressive strength 3.3 to 4.4 N/mm²
- Planked aerated concrete masonry, e.g. plastered, tiled, papered etc.

Versions

- Zinc-plated steel

Functioning

- The FPX-I with internal thread is suitable for pre-positioned installation.
- Pre-drilling enables easy hammering in, even in high-strength aerated concrete. There is no need to clean the drill hole.
- When the anchor is tightened with the hexagon wrench, the internal thread sleeve starts to rotate and the cone is pulled into the square expansion sleeve. The aerated concrete is compressed on the four sides and generates an undercut in the drill hole.
- When reached the optimum expansion, the hexagon wrench is released automatically from the anchor.

Installation FPX-I

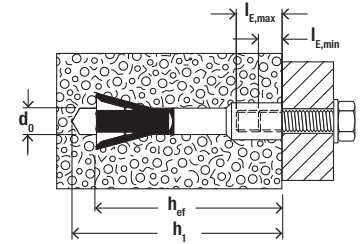
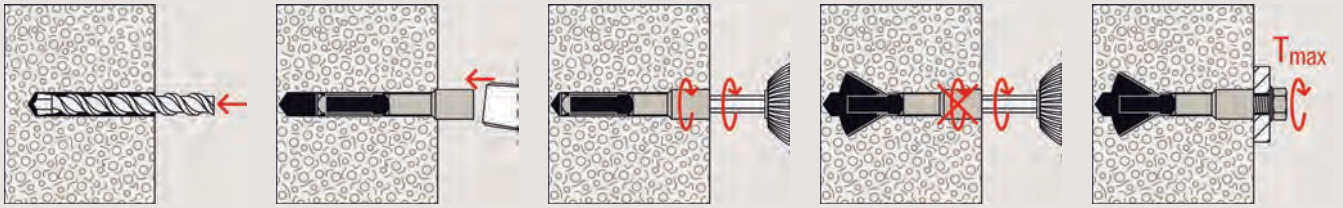

4

Technical data

Aircrete anchor FPX-I



FPX-I

Item	Item No.	Approval	Drill diameter d_0 [mm]	Min. drill hole depth for pre-positioned installation h_1 [mm]	Anchor length l [mm]	Effect. anchorage depth h_{et} [mm]	Min. bolt penetration $l_{E,min}$ [mm]	Max. bolt penetration $l_{E,max}$ [mm]	Sales unit [pcs]
		ETA							
FPX M6-I	519021	●	10	95	75	70	10	15	25
FPX M8-I	519022	●	10	95	75	70	8	15	25
FPX M10-I	519023	●	10	95	75	70	10	15	25
FPX M12-I	519024	●	10	95	75	70	12	15	25

Technical data

Setting tool FPX-I



Setting tool FPX M6 I

Setting tool FPX M8-M12 I

Item	Item No.	Matching anchor type	Sales unit [pcs]
Setting tool FPX M6 I	522517	FPX M6-I	10
Setting tool FPX M8-M12 I	522518	FPX M8-I - FPX M12-I	10

Loads

Aircrete anchor FPX-I

Permissible loads¹⁾ and required component dimensions in cracked and non-cracked aerated concrete wall and slab plates.
For the design the complete current assessment ETA-12/0456 has to be considered.

Type		FPX-I M6 , M8 , M10 , M12
Effective anchorage depth	h_{ef}	[mm] 70
Permissible load²⁾ (F_{perm}) per anchor in cracked AAC-slabs		
$f_{AAC} \geq 3,3 \text{ N/mm}^2 / \rho_m \geq 0,50 \text{ kg/dm}^3$	F_{perm}	[kN] 0.62
$f_{AAC} \geq 4,4 \text{ N/mm}^2 / \rho_m \geq 0,55 \text{ kg/dm}^3$	F_{perm}	[kN] 0.83
Permissible load²⁾ (F_{perm}) per anchor in uncracked AAC-slabs		
$f_{AAC} \geq 3,3 \text{ N/mm}^2 / \rho_m \geq 0,50 \text{ kg/dm}^3$	F_{perm}	[kN] 0.83
$f_{AAC} \geq 4,4 \text{ N/mm}^2 / \rho_m \geq 0,55 \text{ kg/dm}^3$	F_{perm}	[kN] 1.24
Component dimensions		
Minimum member thickness with drill hole cleaning	h_{min}	[mm] 100
Minimum member thickness without drill hole cleaning	h_{min}	[mm] 120
Single anchor		
Minimum spacing	a	[mm] 600
Minimum edge distance	c_1	[mm] 125 / 150 ³⁾
Minimum edge distance orthogonal to c_1	c_2	[mm] 190
Anchor groups⁴⁾ with 2 or 4 anchors		
Actions		shear and oblique tension only axial tension
Minimum spacing between anchor group and 2 single anchors	s_{min}	[mm] 100 100
Minimum edge distance	c_1	[mm] 250 125 / 150 ³⁾
Minimum spacing	a	[mm] 750 600
Minimum edge distance orthogonal to c_1	c_2	[mm] 375 190

¹⁾ Permissible loads of a single anchor for all load directions. The required partial safety factors for material resistance as well as a partial safety factor for load actions of $\gamma_L = 1.4$ are considered.

²⁾ Grade of the screw resp. threaded rod ≥ 4.8 .

³⁾ In case of reinforced plates with a width ≤ 700 mm.

⁴⁾ $F_{perm,group} = 2 \times F_{perm,single\ anchor}$ valid in case of anchor groups with 2 or 4 anchors. Accurate data see ETA.

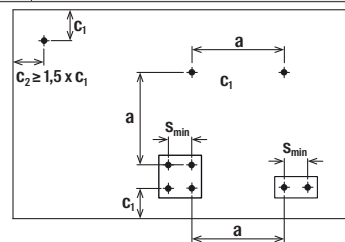

Loads

Aircrete anchor FPX-I

Permissible loads¹⁾ and required component dimensions in aerated concrete masonry.
For the design the complete current assessment ETA-12/0456 has to be considered.

Type		FPX-I M6 , M8 , M10 , M12	
Effective anchorage depth	h_{ef}	[mm]	70
Permissible load²⁾ (F_{perm}) per anchor			
$f_{AAC} \geq 1,6 \text{ N/mm}^2 / \rho_m \geq 0,25 \text{ kg/dm}^3$	F_{perm}	[kN]	0.32
$f_{AAC} \geq 2,0 \text{ N/mm}^2 / \rho_m \geq 0,35 \text{ kg/dm}^3$	F_{perm}	[kN]	0.43
$f_{AAC} \geq 4,0 \text{ N/mm}^2 / \rho_m \geq 0,50 \text{ kg/dm}^3$	F_{perm}	[kN]	0.89
$f_{AAC} \geq 6,0 \text{ N/mm}^2 / \rho_m \geq 0,65 \text{ kg/dm}^3$	F_{perm}	[kN]	1.43
Component dimensions			
Minimum member thickness with drill hole cleaning	h_{min}	[mm]	100
Minimum member thickness without drill hole cleaning	h_{min}	[mm]	120
Single anchor			
Minimum spacing	a	[mm]	375
Minimum edge distance	c_1	[mm]	125
Minimum distance to joints	c_F ³⁾	[mm]	75 ⁴⁾ / 125
Minimum edge distance orthogonal to c_1	c_2	[mm]	190
Anchor groups⁵⁾ with 2 or 4 anchors			
Actions		shear and oblique tension	only axial tension
Minimum spacing between anchor group and 2 single anchors	s_{min}	[mm]	100
Minimum edge distance	c_1	[mm]	250
Minimum spacing	a	[mm]	750
Minimum edge distance orthogonal to c_1	c_2	[mm]	190

¹⁾ Permissible loads of a single anchor for all load directions. The required partial safety factors for material resistance as well as a partial safety factor for load actions of $\gamma_L = 1.4$ are considered.

²⁾ Grade of the screw resp. threaded rod ≥ 4.8 .

³⁾ In case of non visible joints F_{perm} has to be divided in half. Accurate data see ETA.

⁴⁾ c_F for tensile load and/or shear load parallel to the joint which is not filled with mortar with width $\leq 2 \text{ mm}$.



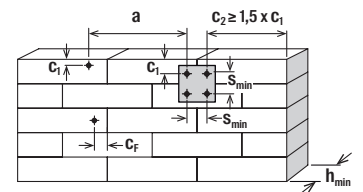













⁵⁾ $F_{perm,group} = 2 \times F_{perm,single\ anchor}$ valid in case of anchor groups with 2 or 4 anchors. Accurate data see ETA.





5

Frame fixings / Stand-off installation

Frame fixing SXRL	304	
Frame fixing SXR	310	
Frame fixing FUR	316	
Anti-corrosion spray FTC-CP	321	
Hammerfix N	322	
Hammerfix N Green	326	
Nail sleeve FNH	328	
Window frame fixing F-S	330	
Metal frame fixing F-M	333	
Window frame screws FFSZ and FFS	336	
Adjustable fixing S10J	340	
Adjustable screw JUSS	342	
Spacing screw ASL	344	
Stand-off installation TherMax 8/10	346	
Stand-off installation TherMax 12/16	350	
Remedial wall tie mechanical VBS-M	356	

Frame fixing SXRL

The versatile with multiple anchorage depth



Timber substructures



Wall consoles

5

Applications

- Façade, ceiling and roof substructures made of wood and metal
- Façade substructures under compression load (e.g. distance installation without a wall bracket)
- Windows
- Gates and doors
- Wardrobes
- Kitchen hanging cabinets
- Squared timbers
- Beams
- TV consoles
- Wall covering
- Metal brackets
- Metal supports
- Cable ducts
- Cable trays

Advantages

- The long expansion element with multiple anchorage depths of 50, 70 or 90 mm for SXRL 8 and SXRL 10 and 70 or 90 mm for SXRL 14 makes the SXRL a versatile applicable product.
- Through the special geometry of the plug, the loads are evenly distributed in the drill hole.
- When the plug is to be set below the plaster, the longer ribs prevent plug rotation during installation.
- The approval for single-point fixing in cracked concrete makes the SXRL the

- designated specialist in concrete particularly for tasks such as the installation of awning roofs and outdoor railings compared to steel anchors.
- SXRL 14 is approved for the application under compression load and is thus for example useable for façade substructures that are mounted at a distance without wall brackets.
- Complete range available with diameters of 8, 10 and 14 mm and usable lengths up to 290 mm.

Certificates



ETA-07/0121, multiple use for non-structural applications



Fire resistance classification R90



INOX STAINLESS STEEL



Building materials

Approved for:

- Vertically perforated brick
- Aerated concrete
- Hollow blocks made from lightweight concrete
- Perforated sand-lime brick
- Thermal insulation blocks
- Solid block made from lightweight and normal weight concrete
- Solid brick
- Solid sand-lime brick
- Concrete \geq C12/15

Also suitable for:

- Natural stone with dense structure
- Solid panel made from gypsum

Versions

- Zinc-plated steel
- Stainless steel

Functioning

- In hollow building materials, the two expansion zones ensure that the introduction of force is gentle on the substrate. The porous block fillets are not crushed by the second expansion zone and therefore serve to transmit the force
- In aerated concrete and solid building material, the two expansion zones combine to form one long expansion element, thus providing for a uniform and flat distribution of the load into substrate.
- SXRL-T with countersunk head screw is recommended for the installation of timber constructions; in the case of metal constructions, use SXRL-FUS with a wide sleeve rim and a moulded washer on the screw, which also features an integrated hexagon socket.

Installation SXRL

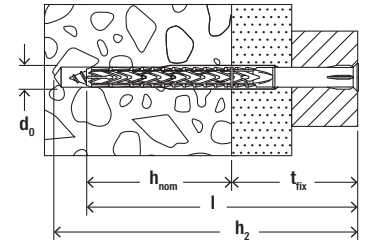
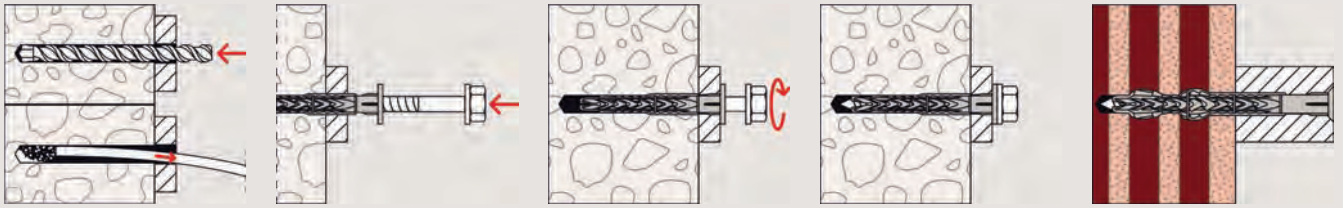

5

Technical data

Frame fixing SXRL-T



SXRL-T with fischer counter-sunk head safety screw

Item	Zinc-plated steel	Stainless steel	Approval		Drill diameter	Min. drill hole depth for through fixings	Usable length at anchorage depth 50mm	Usable length at anchorage depth 70mm	Usable length at anchorage depth 90mm	Anchor length	Drive	Sales unit
	Item No.	Item No.	ETA	DIBt	d ₀ [mm]	h ₂ [mm]	t _{fix} [mm]	t _{fix} [mm]	t _{fix} [mm]	l [mm]		[pcs]
SXRL 8 x 60 T	540113	540119	●	—	8	70	10	—	—	60	T30	50
SXRL 8 x 80 T	540114	540121	●	—	8	90	30	10	—	80	T30	50
SXRL 8 x 100 T	540115	540123	●	—	8	110	50	30	10	100	T30	50
SXRL 8 x 120 T	540116	540124	●	—	8	130	70	50	30	120	T30	50
SXRL 8 x 140 T	540117	540125	●	—	8	150	90	70	50	140	T30	50
SXRL 8 x 160 T	540118	540126	●	—	8	170	110	90	70	160	T30	50
SXRL 10 x 60 T	546477	546505	●	●	10	70	10	—	—	60	T40	50
SXRL 10 x 80 T	522698	522709	●	●	10	90	30	10	—	80	T40	50
SXRL 10 x 100 T	522699	522710	●	●	10	110	50	30	10	100	T40	50
SXRL 10 x 120 T	522700	522711	●	●	10	130	70	50	30	120	T40	50
SXRL 10 x 140 T	522701	522712	●	●	10	150	90	70	50	140	T40	50
SXRL 10 x 160 T	522703	522713	●	●	10	170	110	90	70	160	T40	50
SXRL 10 x 180 T	522704	522714	●	●	10	190	130	110	90	180	T40	50
SXRL 10 x 200 T	522705	522715	●	●	10	210	150	130	110	200	T40	50
SXRL 10 x 230 T	522706	522716	●	●	10	240	180	160	140	230	T40	50
SXRL 10 x 260 T	522707 ¹⁾	522717 ¹⁾	●	●	10	270	210	190	170	260	T40	50
SXRL 10 x 290 T	522708 ¹⁾	522718 ¹⁾	●	●	10	300	240	220	200	290	T40	50
SXRL 14 x 80 T	530920	530932	●	●	14	95	—	10	—	80	T50	50
SXRL 14 x 100 T	530921	530933	●	●	14	115	—	30	10	100	T50	50
SXRL 14 x 120 T	530922	530934	●	●	14	135	—	50	30	120	T50	50
SXRL 14 x 140 T	530923	530935	●	●	14	155	—	70	50	140	T50	50
SXRL 14 x 160 T	530924	530936	●	●	14	175	—	90	70	160	T50	50
SXRL 14 x 180 T	530925	530937	●	●	14	195	—	110	90	180	T50	50
SXRL 14 x 200 T	530926	530938	●	●	14	215	—	130	110	200	T50	50
SXRL 14 x 230 T	530927	530939	●	●	14	245	—	160	140	230	T50	50
SXRL 14 x 260 T	530928	530940	●	●	14	275	—	190	170	260	T50	50
SXRL 14 x 300 T	530929 ¹⁾	530941 ¹⁾	●	●	14	315	—	230	210	300	T50	20
SXRL 14 x 330 T	530930 ¹⁾	530942 ¹⁾	●	●	14	345	—	260	240	330	T50	20
SXRL 14 x 360 T	530931 ¹⁾	530943 ¹⁾	●	●	14	375	—	290	270	360	T50	20

1) not pre-assembled

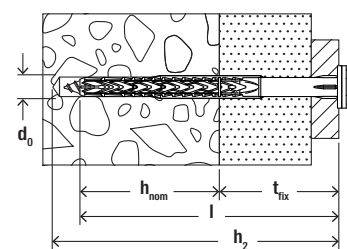

Technical data

Frame fixing SXRL-FUS



SXRL-FUS with fischer hexagon head safety screw, moulded washer and integrated bit recess

5

Item	Zinc-plated steel	Stainless steel	Approval		Drill diameter	Min. drill hole depth for through fixings	Usable length at anchorage depth 50mm	Usable length at anchorage depth 70mm	Usable length at anchorage depth 90mm	Anchor length	Drive	Sales unit
	Item No.	Item No.	ETA	DIBt	d_0 [mm]	h_2 [mm]	t_{fix} [mm]	t_{fix} [mm]	t_{fix} [mm]	l [mm]		[pcs]
SXRL 8 x 60 FUS	540127	540135	●	—	8	70	10	—	—	60	T30/SW10	50
SXRL 8 x 80 FUS	540129	540136	●	—	8	90	30	10	—	80	T30/SW10	50
SXRL 8 x 100 FUS	540130	540137	●	—	8	110	50	30	10	100	T30/SW10	50
SXRL 8 x 120 FUS	540131	—	●	—	8	130	70	50	30	120	T30/SW10	50
SXRL 8 x 140 FUS	540133	—	●	—	8	150	90	70	50	140	T30/SW10	50
SXRL 8 x 160 FUS	540134	—	●	—	8	170	110	90	70	160	T30/SW10	50
SXRL 10 x 60 FUS	546506	546507	●	●	10	70	10	—	—	60	T40/SW13	50
SXRL 10 x 80 FUS	522719	522730	●	●	10	90	30	10	—	80	T40/SW13	50
SXRL 10 x 100 FUS	522720	522731	●	●	10	110	50	30	10	100	T40/SW13	50
SXRL 10 x 120 FUS	522721	522732	●	●	10	130	70	50	30	120	T40/SW13	50
SXRL 10 x 140 FUS	522723	522733	●	●	10	150	90	70	50	140	T40/SW13	50
SXRL 10 x 160 FUS	522724	522734	●	●	10	170	110	90	70	160	T40/SW13	50
SXRL 10 x 180 FUS	522725	522735	●	●	10	190	130	110	90	180	T40/SW13	50
SXRL 10 x 200 FUS	522726	522736	●	●	10	210	150	130	110	200	T40/SW13	50
SXRL 10 x 230 FUS	522727	522737	●	●	10	240	180	160	140	230	T40/SW13	50
SXRL 10 x 260 FUS	522728 ¹⁾	522738 ¹⁾	●	●	10	270	210	190	170	260	T40/SW13	50
SXRL 10 x 290 FUS	522729 ¹⁾	522739 ¹⁾	●	●	10	300	240	220	200	290	T40/SW13	50
SXRL 14 x 80 FUS	530946	—	●	●	14	95	—	10	—	80	T50/SW17	50
SXRL 14 x 80 FUS	—	530955 ²⁾	●	●	14	95	—	10	—	80	SW17	50
SXRL 14 x 100 FUS	530947	—	●	●	14	115	—	30	10	100	T50/SW17	50
SXRL 14 x 100 FUS	—	530956 ²⁾	●	●	14	115	—	30	10	100	SW17	50
SXRL 14 x 120 FUS	530948	—	●	●	14	135	—	50	30	120	T50/SW17	50
SXRL 14 x 120 FUS	—	530957 ²⁾	●	●	14	135	—	50	30	120	SW17	50
SXRL 14 x 140 FUS	530949	—	●	●	14	155	—	70	50	140	T50/SW17	50
SXRL 14 x 140 FUS	—	530958 ²⁾	●	●	14	155	—	70	50	140	SW17	50
SXRL 14 x 160 FUS	530950	—	●	●	14	175	—	90	70	160	T50/SW17	50
SXRL 14 x 160 FUS	—	530959 ²⁾	●	●	14	175	—	90	70	160	SW17	50
SXRL 14 x 180 FUS	530951	—	●	●	14	195	—	110	90	180	T50/SW17	50
SXRL 14 x 180 FUS	—	530960 ²⁾	●	●	14	195	—	110	90	180	SW17	50
SXRL 14 x 200 FUS	530952	—	●	●	14	215	—	130	110	200	T50/SW17	50
SXRL 14 x 200 FUS	—	530961 ²⁾	●	●	14	215	—	130	110	200	SW17	50
SXRL 14 x 230 FUS	530953	—	●	●	14	245	—	160	140	230	T50/SW17	50
SXRL 14 x 230 FUS	—	530962 ²⁾	●	●	14	245	—	160	140	230	SW17	50
SXRL 14 x 260 FUS	530954	—	●	●	14	275	—	190	170	260	T50/SW17	50
SXRL 14 x 260 FUS	—	530963 ²⁾	●	●	14	275	—	190	170	260	SW17	50

1) not pre-assembled

2) without integrated bit recess T50

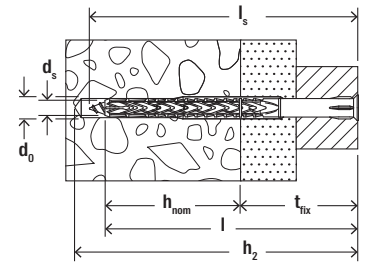

Technical data

Frame fixing SXRL



SXRL without screw

Item	Item No.	Drill diameter d_0 [mm]	Min. drill hole depth for through fixings h_2 [mm]	Usable length at anchorage depth 50mm t_{fix} [mm]	Usable length at anchorage depth 70mm t_{fix} [mm]	Usable length at anchorage depth 90mm t_{fix} [mm]	Anchor length l [mm]	Screw diameter d_s [mm]	Min. screw length l_s [mm]	Sales unit [pcs]
SXRL 8 x 60	540879	8	70	10	—	—	60	5,5 - 6,0	65	100
SXRL 8 x 80	540880	8	90	30	10	—	80	5,5 - 6,0	85	100
SXRL 8 x 100	540881	8	110	50	30	10	100	5,5 - 6,0	105	100
SXRL 8 x 120	540882	8	130	70	50	30	120	5,5 - 6,0	125	100

5

Accessories

Washer U



U

Item	Item No.	External-Ø d [mm]	Hole-Ø D [mm]	Thickness S [mm]	Matching anchor type	Sales unit [pcs]
U 11,5 x 21 x 1,5 DIN 522 A2	010026	21	11.5	1.5	SXR 10, SXRL 10, FUR 10	500

Loads

Frame fixing SXRL 10

Permissible loads of a single anchor¹⁾ in normal concrete of strength class C20/25.
For the design the complete current general construction technique permit Z-21.2-2092 has to be considered.

Type	Material/ surface ²⁾	Nominal anchorage depth h_{nom} [mm]	Cracked concrete					Non-cracked concrete				
			Minimum member thickness h_{min} [mm]	Permissible tension (N_{perm}) and shear loads (V_{perm}); minimum spacing (s_{min}) and edge distances (c_{min}) with reduced loads				Minimum member thickness h_{min} [mm]	Permissible tension (N_{perm}) and shear loads (V_{perm}); minimum spacing (s_{min}) and edge distances (c_{min}) with reduced loads			
			$N_{perm}^{3)}$ [kN]	$V_{perm}^{3)}$ [kN]	$s_{min}^{3)}$ [mm]	$c_{min}^{3)}$ [mm]		$N_{perm}^{3)}$ [kN]	$V_{perm}^{3)}$ [kN]	$s_{min}^{3)}$ [mm]	$c_{min}^{3)}$ [mm]	
SXRL 10	gvz	70	100	1.5	3.6	50	50	110	2.6	6.0	80	80
	R	70	100	1.5	3.6	50	50	110	2.6	6.0	80	80

¹⁾ Design according to EN 1992-4:2018 (for static resp. quasi-static loads). The partial safety factors for material resistance well as a partial safety factor for load actions of $\gamma_L = 1.4$ are considered. As a single anchor counts e.g. an anchor with a spacing $s \geq 3 \times h_{ef}$ and an edge distance $c \geq 1.5 \times h_{ef}$. Accurate data see approval.

²⁾ Further steel grades, versions and technical data see current general construction technique permit.

³⁾ In the case of combinations of tensile and shear loads, bending moments with reduced or minimum spacing and edge distances (anchor groups), the design must be carried out in accordance with the provisions of the complete approval and the provisions of the EN 1992-4:2018. The given loads are valid for temperature range II. We recommend using our anchor design software C-FIX.

Loads

Frame fixing SXRL 8

Recommended loads¹⁾²⁾³⁾ for a single anchor as part of a multiple fixing of non-structural systems.
The given loads are valid for wood screws with the specified diameter.

Type			SXRL 8		
Screw diameter		[mm]	6.0	6.0	6.0
Anchorage depth	h_{nom}	[mm]	50	70	90
Minimum edge distance concrete	c_{min}	[mm]	60	80	100
Recommended loads in the respective base material $F_{rec}^{2)}$					
Concrete	$\geq C20/25$	[kN]	0.60	1.00	1.00
Solid brick	$\geq Mz 12$	[kN]	0.45	0.60	0.60
Solid sand-lime brick	$\geq KS 12$	[kN]	0.40	0.50	0.50
Vertically perforated brick	$\geq Hlz 12; \rho \geq 1.0 [kg/dm^3]$	[kN]	0.15	0.15	0.15
Perforated sand-lime brick	$\geq KSL 12$	[kN]	0.10	0.40	0.40
Aerated concrete	AAC 2	[kN]	–	0.10	0.10
Aerated concrete	AAC 4	[kN]	–	0.15	0.20

¹⁾ Required safety factors are considered.

²⁾ Valid for tensile load, shear load and oblique load under any angle.

³⁾ Valid for zinc coated screws (gvz) and for screws made of stainless steel (R).

For exterior use of the zinc coated screws measures against incoming humidity have to be taken.

Loads

Frame fixing SXRL										
Permissible loads ¹⁾²⁾³⁾ of a single anchor as part of a multiple fixing of non-structural systems. For the design the complete current assessment ETA-07/0121 has to be considered.										
Type		SXRL 8			SXRL 10			SXRL 14		
Anchor diameter	[mm]	8	8	8	10	10	10	14	14	
Anchorage depth	h_{nom} [mm]	50	70	90	50	70	90	70	90	
Anchorage in concrete \geq C12/15										
Permissible tensile load N_{perm}	[kN]	1.59	1.98	1.98	2.18	2.58	2.58	3.37	3.37	
Permissible shear load V_{perm}	zinc coated screws (gvz)	[kN]	4.23	4.23	4.23	5.98	5.98	5.98	12.40	12.40
	stainless steel screw (R)	[kN]	3.93	3.93	3.93	5.98	5.98	5.98	11.63	11.63
Minimum member thickness	h_{min} [mm]	80	100	120	100	100	120	110	130	
Characteristic edge distance	$c_{cr,N}$ [mm]	85	85	85	140	140	140	140	140	
Characteristic spacing	a resp. $s_{cr,N}$ [mm]	90	105	105	120	120	120	135	135	
Minimum spacing	s_{min} [mm]	85	85	85	70	70	70	85	85	
with an edge distance	$c \geq$ [mm]	85	85	85	140	140	140	140	140	
Minimum edge distance	c_{min} [mm]	85	85	85	70	70	70	85	85	
with a spacing	$s \geq$ [mm]	85	85	85	175	175	175	175	175	
Anchorage in narrow concrete members ($h \geq 40$ mm) made of concrete \geq C12/15, e.g. weather shells of triple-skin outer wall panels										
Permissible tensile load N_{perm}	[kN]	-	-	-	0.99	-	-	-	-	
Permissible shear load V_{perm}	[kN]	-	-	-	5.98	-	-	-	-	
Anchorage in pre-stressed hollow-core concrete slabs (mirror thickness $d_b \geq 30$ mm) made of concrete \geq C45/55										
Permissible tensile load N_{perm}	[kN]	-	-	-	1.39	-	-	-	-	
Permissible shear load V_{perm}	[kN]	-	-	-	5.98	-	-	-	-	
Anchorage in masonry										
Permissible load ⁴⁾ F_{perm} in solid brick	$\geq Mz$ 12/1.8; $\geq NF$	[kN]	0.57	0.71	0.71	0.57	1.14	-	0.86	0.86
	$\geq Mz$ 20/1.8; $\geq NF$	[kN]	0.86	1.14	1.14	1.00	1.14	-	1.14	1.14
Permissible load ⁴⁾ F_{perm} in solid sand-lime brick	$\geq KS$ 10/1.8; $\geq NF$	[kN]	0.57	0.57	0.57	-	0.71	-	0.86	0.86
	$\geq KS$ 20/1.8; $\geq NF$	[kN]	0.71	0.86	0.86	-	1.00	-	1.29	1.29
Permissible load ⁴⁾ F_{perm} in lightweight concrete block	$\geq Vbl$ 2; $\rho \geq 1.2$ kg/dm ³	[kN]	0.11	0.26	0.26	0.11	0.11	-	0.26	0.26
	$\geq Vbl$ 6; $\rho \geq 1.6$ kg/dm ³	[kN]	0.34	0.57	0.57	0.57	1.29	-	0.57	0.57
Permissible load ⁴⁾⁵⁾ F_{perm} in vertically perforated brick	$\geq HLz$ 10; $\rho \geq 1.2$ kg/dm ³	[kN]	0.17	0.17	0.17	-	-	-	-	-
	$\geq HLz$ 12; $\rho \geq 1.0$ kg/dm ³	[kN]	-	-	-	-	0.21	-	0.57	0.71
Permissible load ⁴⁾ F_{perm} in perforated sand-lime brick	$\geq KSL$ 12; $\rho \geq 1.4$ kg/dm ³	[kN]	0.34	0.43	0.43	-	0.71	-	0.43	0.71
	$\geq Hbl$ 2; $\rho \geq 0.7$ kg/dm ³	[kN]	0.43	0.57	0.43	0.57	0.71	-	0.34	0.21
Permissible load ⁴⁾⁵⁾ F_{perm} in hollow lightweight concrete blocks	$\geq Hbl$ 2; $\rho \geq 0.7$ kg/dm ³	[kN]	0.43	0.57	0.43	0.57	0.71	-	0.34	0.21
Permissible load ⁴⁾⁵⁾ F_{perm} in ceilings made of vertically perforated bricks	$f_b \geq 10$ N/mm ² ; $\rho \geq 0.7$ kg/dm ³	[kN]	-	-	-	-	0.57	-	-	-
Minimum member thickness	h_{min} [mm]	115	115	115	110	110	110	115	115	
Minimum spacing (single anchor)	a_{min} [mm]	250	250	250	250	250	250	250	250	
Minimum spacing (anchor group)	s_{min} [mm]	100	100	100	100	100	100	100	100	
Minimum edge distance (anchor group)	c_{min} [mm]	100	100	100	100	100	100	100	100	
Anchorage in aerated concrete										
Permissible load ⁴⁾ F_{zul} in aerated concrete	AAC ≥ 2 N/mm ²	[kN]	-	0.14	0.21	-	0.18	0.21	0.32	0.43
	AAC ≥ 4 N/mm ²	[kN]	-	0.32	0.43	-	0.43	0.54	0.89	1.07
	AAC ≥ 6 N/mm ²	[kN]	-	0.54	0.71	-	0.71	0.89	1.43	1.79
Minimum member thickness	h_{min} [mm]	-	175	175	-	100	120	175 ⁶⁾ /300 ⁷⁾	175 ⁶⁾ /300 ⁷⁾	
Minimum spacing (single anchor)	a_{min} [mm]	-	250	250	-	250	250	250	250	
Minimum spacing (anchor group)	s_{min} [mm]	-	80 ⁶⁾ /110 ⁸⁾	80 ⁶⁾ /110 ⁸⁾	-	100 ⁶⁾ /120 ⁸⁾	100 ⁶⁾ /120 ⁸⁾	80	100 ⁶⁾ /125 ⁷⁾	
Minimum edge distance (anchor group)	c_{min} [mm]	-	90 ⁶⁾ /110 ⁸⁾	90 ⁶⁾ /110 ⁸⁾	-	120	120	120	120 ⁶⁾ /150 ⁷⁾	

¹⁾ Valid for zinc coated screws (gvz) and for screws made of stainless steel (R). For exterior use of the zinc coated screws measures against incoming humidity according to assessment have to be taken.

²⁾ The required partial safety factors for material resistance as well as a partial safety factor for load actions $\gamma_L = 1.4$ are considered.

As a single anchor counts e.g. an anchor with a minimum spacing a according to Annex B 4 of the assessment.

³⁾ Valid for temperatures in the substrate up to +50 °C (resp. short term up to +80 °C). For long term temperatures up to +30 °C higher permissible loads may be possible.

⁴⁾ Valid for tensile load, shear load and oblique load under any angle. For combinations of tensile loads, shear loads and bending moments see assessment.

⁵⁾ Rotary drilling.

⁶⁾ Only valid for AAC with compression strength ≥ 2 to < 4 N/mm².

⁷⁾ Only valid for AAC with compression strength ≥ 4 N/mm².

⁸⁾ Only valid for AAC with compression strength ≥ 6 N/mm².

Frame fixing SXR

The efficient with short expansion element



Façade substructures



Façade substructures

5

Applications

- Façade, ceiling and roof substructures made of wood and metal
- Windows
- Gates and doors
- Wardrobes
- Kitchen hanging cabinets
- Squared timbers
- Beams
- TV consoles
- Wall covering
- Metal brackets
- Metal supports
- Cable ducts
- Cable trays

Advantages

- The special functioning allows for use in solid and hollow building materials with an anchorage depth of just 50 mm, ensuring an economical fixing.
- The ETA assessment covers use in a range of solid and hollow building materials, and guarantees a secure fixing.
- The specially developed combination of plugs and screws ensures the very best handling. The plug has a noticeable hold, making installation more convenient.
- Extensive range with diameters of 6, 8 and 10 mm, usable lengths up to 210 mm.

Certificates



ETA-07/0121, multiple use for non-structural applications



Fire resistance classification R90



INOX STAINLESS STEEL



Building materials

Approved for:

- Concrete \geq C12/15
- Vertically perforated brick
- Hollow blocks made from lightweight concrete
- Perforated sand-lime brick
- Solid sand-lime brick
- Aerated concrete
- Solid block made from lightweight and normal weight concrete
- Solid brick
- Thermal insulation blocks

Also suitable for:

- Natural stone with dense structure
- Solid panel made from gypsum

Functioning

- The SXR is suitable for push-through installation.
- The SXR expands in solid building materials. In hollow building materials the loads are transmitted to the substrate webs.
- With vertically perforated bricks, only use rotary drilling (no impact drilling).
- SXR-T with countersunk head screw is recommended for the installation of timber constructions; in the case of metal constructions, use SXR-FUS with a wide sleeve rim and a moulded washer on the screw, which also features an integrated hexagon socket.

Versions

- Zinc-plated steel
- Stainless steel
- Hot-dip galvanised steel

Installation SXR

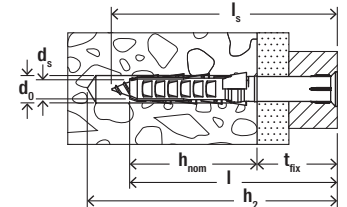
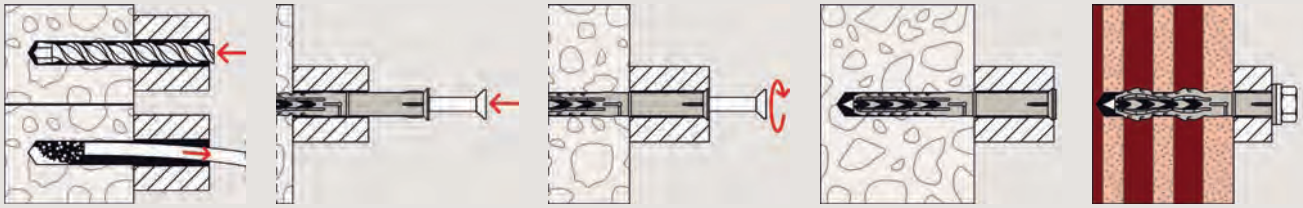

5

Technical data

Frame fixing SXR



SXR without screw

Item	Item No.	Drill hole diameter	Min. drill hole depth for through fixings	Min. anchorage depth	Anchor length	Screw diameter	Min. screw length	Max. fixture thickness	Sales unit
		d_0 [mm]	h_2 [mm]	h_{nom} [mm]	l [mm]	d_s [mm]	l_s [mm]	t_{fix} [mm]	[pcs]
SXR 6 x 60	503230	6	70	30	60	4,5	65	30	100
SXR 8 x 60	506194	8	70	50	60	5,5 - 6,0	65	10	100
SXR 8 x 80	506196	8	90	50	80	5,5 - 6,0	85	30	100
SXR 8 x 100	506198	8	110	50	100	5,5 - 6,0	125	50	100
SXR 8 x 120	506199	8	130	50	120	5,5 - 6,0	105	70	100

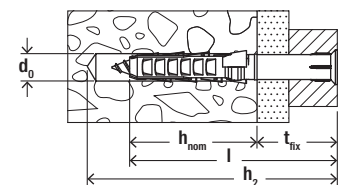

Technical data

Frame fixing SXR-Z



SXR-Z - with zinc-plated countersunk head screw with cross drive PZ

Item	Item No.	Drill hole diameter	Min. drill hole depth for through fixings	Min. anchorage depth	Anchor length	Max. fixture thickness	Drive	Sales unit
		d_0 [mm]	h_2 [mm]	h_{nom} [mm]	l [mm]	t_{fix} [mm]		[pcs]
SXR 6 x 60 Z	503233 ¹⁾	6	70	30	60	30	PZ2	50

1) not pre-assembled

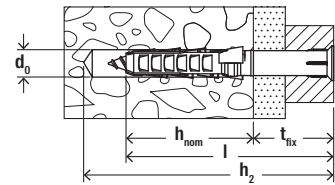

Technical data

Frame fixing SXR-T



SXR-T with fischer counter-sunk head safety screw

5

	Zinc-plated steel	Stainless steel	Hot-dip galvanised steel	Approval	Drill hole diameter	Min. drill hole depth for through fixings	Min. anchorage depth	Anchor length	Max. fixture thickness	Drive	Sales unit
	Item No.	Item No.	Item No.		d_0 [mm]	h_2 [mm]	h_{nom} [mm]	l [mm]	t_{fix} [mm]		[pcs]
Item	gvz	R	hdg	ETA							
SXR 8 x 60 T	502999	—	—	●	8	70	50	60	10	T30	50
SXR 8 x 80 T	503000	—	—	●	8	90	50	80	30	T30	50
SXR 8 x 100 T	503001	—	—	●	8	110	50	100	50	T30	50
SXR 8 x 120 T	503002	—	—	●	8	130	50	120	70	T30	50
SXR 10 x 80 T	046263	046272	—	●	10	90	50	80	30	T40	50
SXR 10 x 100 T	046264	046274	—	●	10	110	50	100	50	T40	50
SXR 10 x 100 T	—	—	509534	—	10	110	50	100	50	T40	50
SXR 10 x 120 T	046265	046278	—	●	10	130	50	120	70	T40	50
SXR 10 x 120 T	—	—	509535	—	10	130	50	120	70	T40	50
SXR 10 x 140 T	046266	046279	—	●	10	150	50	140	90	T40	50
SXR 10 x 140 T	—	—	509536	—	10	150	50	140	90	T40	50
SXR 10 x 160 T	046267	046283	—	●	10	170	50	160	110	T40	50
SXR 10 x 180 T	046268	046285	—	●	10	190	50	180	130	T40	50
SXR 10 x 200 T	046269	046286	—	●	10	210	50	200	150	T40	50
SXR 10 x 230 T	046270	046287	—	●	10	240	50	230	180	T40	50
SXR 10 x 260 T	046271	—	—	●	10	270	50	260	210	T40	50

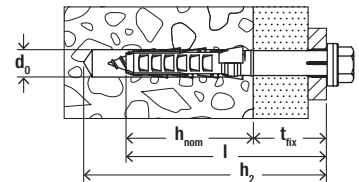

Technical data

Frame fixing SXR-FUS



SXR-FUS - with fischer hexagon head safety screw, moulded washer and integrated T40 bit recess

	Zinc-plated steel	Stainless steel	Hot-dip galvanised steel	Approval	Drill hole diameter	Min. drill hole depth for through fixings	Min. anchorage depth	Anchor length	Max. fixture thickness	Drive	Sales unit
	Item No.	Item No.	Item No.		d_0 [mm]	h_2 [mm]	h_{nom} [mm]	l [mm]	t_{fix} [mm]		[pcs]
Item	gvz	R	hdg	ETA							
SXR 10 x 52 FUS	502456 ¹⁾	—	—	●	10	62	50	52	2	T40/SW13	50
SXR 10 x 60 FUS	046329	046339	—	●	10	70	50	60	10	T40/SW13	50
SXR 10 x 60 FUS	—	—	509537	—	10	70	50	60	10	T40/SW13	50
SXR 10 x 80 FUS	046330	046340	—	●	10	90	50	80	30	T40/SW13	50

1) not pre-assembled

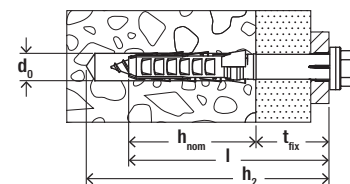

Technical data

Frame fixing SXR-FUS



SXR-FUS - with fischer hexagon head safety screw, moulded washer and integrated T40 bit recess

	Zinc-plated steel	Stainless steel	Hot-dip galvanised steel	Approval	Drill hole diameter	Min. drill hole depth for through fixings	Min. anchorage depth	Anchor length	Max. fixture thickness	Drive	Sales unit
	Item No.	Item No.	Item No.		d_0 [mm]	h_2 [mm]	h_{nom} [mm]	l [mm]	t_{fix} [mm]		[pcs]
Item	gvz	R	hdg	ETA							
SXR 10 x 80 FUS	—	—	509538	—	10	90	50	80	30	T40/SW13	50
SXR 10 x 100 FUS	046331	046342	—	●	10	110	50	100	50	T40/SW13	50
SXR 10 x 100 FUS	—	—	509539	—	10	110	50	100	50	T40/SW13	50
SXR 10 x 120 FUS	046332	046343	—	●	10	130	50	120	70	T40/SW13	50
SXR 10 x 140 FUS	046333	046344	—	●	10	150	50	140	90	T40/SW13	50
SXR 10 x 140 FUS	—	—	509540	—	10	150	50	140	90	T40/SW13	50
SXR 10 x 160 FUS	046334	046345	—	●	10	170	50	160	110	T40/SW13	50
SXR 10 x 180 FUS	046335	046361	—	●	10	190	50	180	130	T40/SW13	50
SXR 10 x 200 FUS	046336	046362	—	●	10	210	50	200	150	T40/SW13	50
SXR 10 x 230 FUS	046337	046363	—	●	10	240	50	230	180	T40/SW13	50
SXR 10 x 260 FUS	046338	—	—	●	10	270	50	260	210	T40/SW13	50

1) not pre-assembled

Accessories

Washer U



U

	Item No.	External-Ø d [mm]	Hole-Ø D [mm]	Thickness S [mm]	Matching anchor type	Sales unit [pcs]
Item						
U 11,5 x 21 x 1,5 DIN 522 A2	010026	21	11.5	1.5	SXR 10, SXRL 10, FUR 10	500

Accessories

Aircrete hole punch GBS



GBS

Item	Item No.	Drill hole d_0 [Ø mm]	Min. drill hole depth for through fixings h_2 [mm]	Match	Sales unit [pcs]
GBS 10 x 80	050590 ¹⁾	9	85	SXR 10 x 52, SXR 10 x 60, SXR 10 x 80	1
GBS 10 x 100	050591 ¹⁾	9	105	SXR 10 x 100	1
GBS 10 x 135	050593 ¹⁾	9	140	SXR 10 x 120	1
GBS 10 x 160	050594 ¹⁾	9	165	SXR 10 x 140, SXR 10 x 160	1
GBS 10 x 185	050595 ¹⁾	9	190	SXR 10 x 180	1
GBS 10 x 230	050596 ¹⁾	9	235	SXR 10 x 200, SXR 10 x 230	1

¹⁾ According to the ETA, the aircrete hole punch GBS must be used for drill-hole production in aerated concrete PB < 4N/mm².

Loads

Frame fixing SXR

Recommended loads¹⁾ of a single anchor as part of a multiple fixing of non-structural systems.
The given loads are valid for wood screws with the specified diameter.

Type		SXR 6	SXR 8
Screw diameter	[mm]	4.5	6.0
Anchorage depth	h_{nom} [mm]	30	50
Minimum edge distance concrete	c_{min} [mm]	50	60
Recommended loads in the respective base material F_{rec} ²⁾			
Concrete	≥ C20/25	[kN] 0.25	0.40
Solid brick	≥ Mz 12	[kN] 0.20	0.30
Solid sand-lime brick	≥ KS 12	[kN] 0.20	0.30
Vertically perforated brick	≥ Hlz 12; $\rho \geq 1.0$ [kg/dm ³]	[kN] 0.10	0.10
Perforated sand-lime brick	≥ KSL 12	[kN] 0.20	0.30

¹⁾ Valid for zinc coated screws (gvz) and for screws made of stainless steel (R). For exterior use of the zinc coated screws measures against incoming humidity have to be taken. Required safety factors are considered.

²⁾ Valid for tensile load, shear load and oblique load under any angle.

Loads

Frame fixing SXR			
Type		SXR 8	SXR 10
Permissible loads ¹⁾²⁾³⁾ of a single anchor as part of a multiple fixing of non-structural systems. For the design the complete current assessment ETA-07/0121 has to be considered.			
Anchor diameter	[mm]	8	10
Anchorage depth	h_{nom}	[mm]	50
Anchorage in concrete \geq C12/15			
Permissible tensile load N_{perm}		[kN]	0.99
Permissible shear load V_{perm}	zinc coated screws (gvz)	[kN]	4.23
	stainless steel screw (R)	[kN]	3.93
Minimum member thickness	h_{min}	[mm]	100
Characteristic edge distance	$c_{cr,N}$	[mm]	70
Characteristic spacing	a resp. $s_{cr,N}$	[mm]	70
Minimum spacing	s_{min}	[mm]	70
with an edge distance	$c \geq$	[mm]	70
Minimum edge distance	c_{min}	[mm]	70
with a spacing	$s \geq$	[mm]	70
Anchorage in narrow concrete members ($h \geq 40$ mm) made of concrete \geq C12/15, e.g. weather shells of triple-skin outer wall panels			
Permissible tensile load N_{perm}		[kN]	-
Permissible shear load V_{perm}		[kN]	-
Anchorage in masonry			
Permissible load ⁴⁾ F_{perm} in solid brick	$\geq Mz 12/1.8; \geq NF$	[kN]	0.57
	$\geq Mz 20/1.8; \geq NF$	[kN]	0.71
Permissible load ⁴⁾ F_{perm} in solid sand-lime brick	$\geq KS 10/1.8; \geq NF$	[kN]	0.57
	$\geq KS 20/1.8; \geq NF$	[kN]	0.71
Permissible load ⁴⁾ F_{perm} in lightweight concrete block	$\geq Vbl 2; \rho \geq 1.2 \text{ kg/dm}^3$	[kN]	0.26
	$\geq Vbl 6; \rho \geq 1.6 \text{ kg/dm}^3$	[kN]	0.26
Permissible load ⁴⁾⁵⁾ F_{perm} in vertically perforated brick	$\geq HLz 12; \rho \geq 1.0 \text{ kg/dm}^3$	[kN]	0.17
Permissible load ⁴⁾ F_{perm} in perforated sand-lime brick	$\geq KSL 8; \rho \geq 1.4 \text{ kg/dm}^3$	[kN]	0.26
	$\geq KSL 12; \rho \geq 1.4 \text{ kg/dm}^3$	[kN]	0.57
Permissible load ⁴⁾⁵⁾ F_{perm} in hollow lightweight concrete blocks	$\geq Hbl 2; \rho \geq 0.7 \text{ kg/dm}^3$	[kN]	-
	$\geq Hbl 6; \rho \geq 1.2 \text{ kg/dm}^3$	[kN]	0.43
Minimum member thickness	h_{min}	[mm]	100
Minimum spacing (single anchor)	a_{min}	[mm]	250
Minimum spacing (anchor group)	s_{min}	[mm]	100
Minimum edge distance (anchor group)	c_{min}	[mm]	100
Anchorage in aerated concrete			
Permissible load ⁴⁾ F_{zul} in aerated concrete	$AAC \geq 2 \text{ N/mm}^2$	[kN]	-
	$AAC \geq 4 \text{ N/mm}^2$	[kN]	-
	$AAC \geq 6 \text{ N/mm}^2$	[kN]	-
Minimum member thickness	h_{min}	[mm]	-
Minimum spacing (single anchor)	a_{min}	[mm]	-
Minimum spacing (anchor group)	s_{min}	[mm]	-
Minimum edge distance (anchor group)	c_{min}	[mm]	-

¹⁾ Valid for zinc coated screws (gvz) and for screws made of stainless steel (R). For exterior use of the zinc coated screws measures against incoming humidity according to assessment have to be taken.

²⁾ The required partial safety factors for material resistance as well as a partial safety factor for load actions $\gamma_L = 1.4$ are considered.

As a single anchor counts e.g. an anchor with a minimum spacing according to assessment.

³⁾ Valid for temperatures in the substrate up to +50 °C (resp. short term up to +80 °C).

⁴⁾ Valid for tensile load, shear load and oblique load under any angle. For combinations of tensile loads, shear loads and bending moments see assessment.

⁵⁾ Rotary drilling.

⁶⁾ Drill holes to be made with aerated concrete hole punch.

Frame fixing FUR

The lamella plug with gentle power transfer



Façade substructures

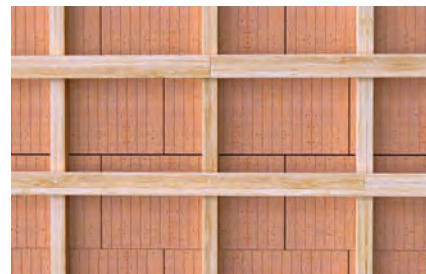

Timber substructures

5

Applications

- Façade, ceiling and roof substructures made of wood and metal
- Windows
- Gates and doors
- Squared timbers
- Beams
- Wall covering

Certificates



ETA-13/0235, multiple use for non-structural applications



Fire resistance classification R90



INOX STAINLESS STEEL

Advantages

- The operating principle with an anchorage depth of 70 mm and proven asymmetrical teeth, makes it an assembly-friendly anchor even in an unknown base material.
- The slim geometry guarantees a simple

installation, even in cases involving thick wooden fixtures and narrow drill holes.

- Range available with diameters of 8 and 10 mm and usable lengths up to 160 mm.

Building materials

Approved for:

- Concrete \geq C12/15
- Vertically perforated brick
- Perforated sand-lime brick
- Solid sand-lime brick
- Solid brick made from lightweight concrete
- Solid brick

Also suitable for:

- Natural stone with dense structure
- Solid panel made from gypsum
- Hollow blocks made from lightweight concrete
- Three-layer composite exterior wall panels
- Lightweight aggregate concrete

Functioning

- The FUR is suitable for push-through installation.
- Screwing in the screw causes the individual teeth to expand. In solid materials, the teeth create even expansion forces. In hollow materials, the teeth expand through the solid part of the block and form an undercut in the cavity.
- With vertically perforated bricks, only use rotary drilling (no impact drilling).
- FUR-T with countersunk head screw is recommended for the installation of timber constructions; in the case of metal constructions, use FUR-FUS with a wide sleeve rim and a moulded washer on the screw.

Versions

- Zinc-plated steel
- Stainless steel

Installation FUR

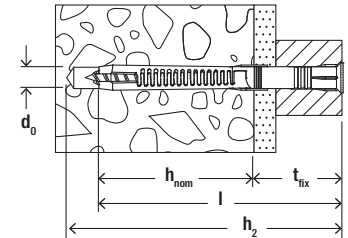
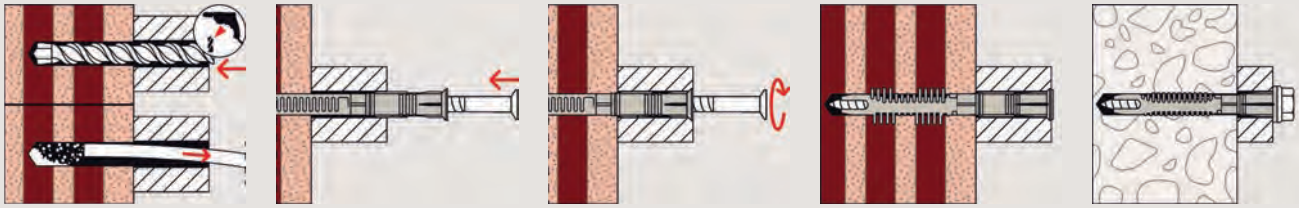

5

Technical data

Frame fixing FUR-T



FUR-T - with fischer counter-sunk head safety screw

Item	Zinc-plated steel	Stainless steel	Approval	Drill hole diameter	Min. drill hole depth for through fixings	Min. anchor age depth	Anchor length	Max. fixture thickness	Drive	Sales unit
	Item No.	Item No.		d_0 [mm]	h_2 [mm]	h_{nom} [mm]	l [mm]	t_{fix} [mm]		[pcs]
FUR 8 x 80 T	070110	070120	—	8	90	70	80	10	T30	50
FUR 8 x 100 T	070111	070121	—	8	110	70	100	30	T30	50
FUR 8 x 120 T	070112	070122	—	8	130	70	120	50	T30	50
FUR 10 x 80 T	088756	088784	●	10	90	70	80	10	T40	50
FUR 10 x 100 T	088757	088785	●	10	110	70	100	30	T40	50
FUR 10 x 115 T	088760	088791	●	10	125	70	115	45	T40	50
FUR 10 x 135 T	088758	088786	●	10	145	70	135	65	T40	50
FUR 10 x 160 T	088759	088787	●	10	170	70	160	90	T40	50
FUR 10 x 185 T	088761	088788	●	10	195	70	185	115	T40	50
FUR 10 x 200 T	088764	088789	●	10	210	70	200	130	T40	50
FUR 10 x 230 T	088762	088790	●	10	240	70	230	160	T40	50

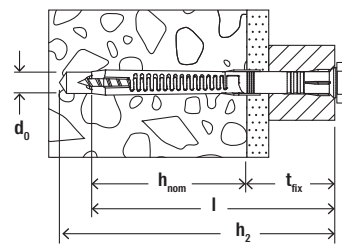

Technical data

Frame fixing FUR-SS



FUR-SS - with fischer hexagon head safety screw

5

Item	Zinc-plated steel	Stainless steel	Approval	Drill hole diameter	Min. drill hole depth for through fixings	Min. anchor- age depth	Anchor length	Max. fixture thickness	Drive	Sales unit
	Item No.	Item No.		d_0 [mm]	h_2 [mm]	h_{nom} [mm]	l [mm]	t_{fix} [mm]		[pcs]
	gvz	R	ETA							
FUR 8 x 80 SS	070130	070140	—	8	90	70	80	10	SW 10	50
FUR 8 x 100 SS	070131	—	—	8	110	70	100	30	SW 10	50
FUR 8 x 120 SS	070132	—	—	8	130	70	120	50	SW 10	50
FUR 10 x 80 SS	088776	088792	●	10	90	70	80	10	SW 13	50
FUR 10 x 100 SS	088777	—	●	10	110	70	100	30	SW 13	50
FUR 10 x 115 SS	088783	088799	●	10	125	70	115	45	SW 13	50
FUR 10 x 135 SS	088778	088794	●	10	145	70	135	65	SW 13	50
FUR 10 x 160 SS	088779	088795	●	10	170	70	160	90	SW 13	50
FUR 10 x 185 SS	088780	088796	●	10	195	70	185	115	SW 13	50
FUR 10 x 200 SS	088781	088797	●	10	210	70	200	130	SW 13	50
FUR 10 x 230 SS	088782	088798	●	10	240	70	230	160	SW 13	50

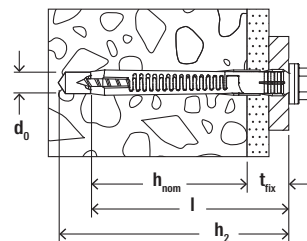

Technical data

Frame fixing FUR-FUS



FUR-FUS - with fischer hexagon head safety screw, moulded washer and integrated bit recess

Item	Zinc-plated steel	Stainless steel	Approval	Drill hole diameter	Min. drill hole depth for through fixings	Min. anchor- age depth	Anchor length	Max. fixture thickness	Drive	Sales unit
	Item No.	Item No.		d_0 [mm]	h_2 [mm]	h_{nom} [mm]	l [mm]	t_{fix} [mm]		[pcs]
	gvz	R	ETA							
FUR 10 x 80 FUS	093527 ¹⁾	093528 ¹⁾	●	10	90	70	80	10	T40/SW13	50
FUR 10 x 100 FUS	097797 ¹⁾	—	●	10	110	70	100	30	T40/SW13	50

1) Collar: Ø 18 x 2 mm.

Accessories

Washer U



U

Item	Item No.	External-Ø d [mm]	Hole-Ø D [mm]	Thickness S [mm]	Matching anchor type	Sales unit [pcs]
U 11,5 x 21 x 1,5 DIN 522 A2	010026	21	11.5	1.5	SXR 10, SXRL 10, FUR 10	500

Loads

Frame fixing FUR 10

Permissible loads¹⁾²⁾³⁾ of a single anchor as part of a multiple fixing of non-structural systems.
For the design the complete current assessment ETA-13/0235 has to be considered.

Type		FUR 10
Anchor diameter		[mm] 10
Anchorage depth	h_{nom}	[mm] 10
Anchorage in concrete \geq C12/15		
Permissible tensile load N_{perm}		[kN] 1.79
Permissible shear load V_{perm}	zinc coated screws (gvz)	[kN] 5.37
	stainless steel screw (R)	[kN] 4.98
Minimum member thickness	h_{min}	[mm] 110
Characteristic edge distance	$c_{cr,N}$	[mm] 140
Characteristic spacing	a resp. $s_{cr,N}$	[mm] 90
Minimum spacing	s_{min}	[mm] 70
with an edge distance	$c \geq$	[mm] 140
Minimum edge distance	c_{min}	[mm] 70
with a spacing	$s \geq$	[mm] 210
Anchorage in masonry		
Permissible load ⁴⁾ F_{perm} in solid brick	\geq Mz 10, NF; $\rho \geq 1.8 \text{ kg/dm}^3$	[kN] 0.71
	\geq Mz 12, NF; $\rho \geq 1.8 \text{ kg/dm}^3$	[kN] 0.86
Permissible load ⁴⁾ F_{perm} in solid sand-lime brick	\geq KS 10, NF; $\rho \geq 1.8 \text{ kg/dm}^3$	[kN] 0.57
	\geq KS 20, NF; $\rho \geq 1.8 \text{ kg/dm}^3$	[kN] 0.71
Permissible load ⁴⁾ F_{perm} in lightweight concrete block	\geq Vbl 6; $\rho \geq 1.6 \text{ kg/dm}^3$	[kN] 0.57
	\geq Vbl 8; $\rho \geq 1.6 \text{ kg/dm}^3$	[kN] 0.86
Permissible load ⁴⁾⁵⁾ F_{perm} in vertically perforated brick, Form B (e.g. Poroton)	\geq HLz 12; $\rho \geq 1.4 \text{ kg/dm}^3$	[kN] 0.37
	\geq HLz 20; $\rho \geq 1.4 \text{ kg/dm}^3$	[kN] 0.57
Permissible load ⁴⁾ F_{perm} in perforated sand-lime brick	\geq KSL 12, 2 DF; $\rho \geq 1.6 \text{ kg/dm}^3$	[kN] 0.57
	\geq KSL 16, 2 DF; $\rho \geq 1.6 \text{ kg/dm}^3$	[kN] 0.71
Minimum member thickness	h_{min}	[mm] 110
Minimum spacing (single anchor)	a_{min}	[mm] 250
Minimum spacing (anchor group)	s_{min}	[mm] 100
Minimum edge distance	c_{min}	[mm] 100

¹⁾ Valid for zinc coated screws (gvz) and for screws made of stainless steel (R). For exterior use of the zinc coated screws measures against incoming humidity according to assessment have to be taken.

²⁾ The partial safety factors for material resistance as regulated in the assessment as well as a partial safety factor for load actions $\gamma_L = 1.4$ are considered.

As a single anchor counts e.g. an anchor with a minimum spacing according to assessment.

³⁾ Valid for temperatures in the substrate up to +50 °C (resp. short term up to +80 °C).

⁴⁾ Valid for tensile load, shear load and oblique load under any angle. For combinations of tensile loads, shear loads and bending moments see assessment.

⁵⁾ Rotary drilling.

Loads

Frame fixing FUR 8

Highest recommended loads¹⁾²⁾³⁾ for a single anchor for multiple fixings of non-structural applications.
The given loads are valid for fischer safety screws with the specified diameter.

Type		FUR 8
Diameter of the safety screw	[mm]	6.0
Anchorage depth	h_{nom} [mm]	70
Minimum edge distance concrete	c_{min} [mm]	50
Recommended loads in the respective base material F_{rec} ²⁾		
Concrete	\geq C12/15 [kN]	1.00
Solid brick	\geq Mz 12 [kN]	0.60
Solid sand-lime brick	\geq KS 12 [kN]	0.60

¹⁾ Required safety factors are considered.

²⁾ Valid for tensile load, shear load and oblique load under any angle.

³⁾ Valid for zinc coated screws and for screws made of stainless steel. For exterior use of the zinc coated screws measures against incoming humidity have to be taken.

Anti-corrosion spray FTC-CP

The elastic protective coating for use with frame fixings



Sealing of the screw heads



Sealing of the screw heads

5

Applications

- Façade anchorings in line with the assessments for frame fixings, e.g. SXR, SXRL and FUR.
- For all substructures, e.g. made from wood, aluminium, metal.

Building materials

- Zinc-plated frame fixings
- Corrosive metals

Advantages

- FTC-CP professionally prevents the penetration of moisture into the anchor shaft and securely protects the connection from corrosion - as required in the ETA assessments.
- Once dry, the optimised formulation provides a long-lasting, elastic protective

coating with a secure hold and a high abrasion resistance.

- The thixotropic anti-corrosion agent is also ideally suited to other corrosion protection applications and thus offers a wide range of uses.

Functioning

- Thixotropic, bitumen-based anti-corrosion agent.
- Good stability under load; non-drip, no spray mist.
- Shake canister for at least 2 minutes from the time the mixing balls can be heard.
- Spray as evenly as possible from a distance of 15 to 20 cm.
- Ideal processing temperature +16 °C to +25 °C.
- Quick-drying (dried through after 3-4 hours at 600 m μ and 20 °C).
- Temperature-resistant from -25 °C to 80 °C.
- Salt and water-resistant, and resistant to abrasion.
- With one can about 300 screw heads can be coated.

Technical data

Anti-corrosion spray FTC-CP				
Item	Item No.	Colour	Content per can [ml]	Sales unit [pcs]
FTC-CP	511440 ¹⁾	black	500	1

1) Dangerous goods - no express shipping possible.

Hammerfix N

The hammer-in plug for a simple, fast and economical installation



5



Timber substructures



Cable ducts

Applications

- Substructures made of wood and metal
- Wall connection or plaster profiles
- Slides
- Sheets
- Cable and pipe clips
- Perforated tapes

Advantages

- The rapid hammerset installation reduces the amount of time required and allows for an economic series installation.
- The integrated hammer-in stop prevents the plug from expanding prematurely (jamming), thus enabling a problem-free installation.
- Together with the cross-slot recess, the

- thread of the nail screw allows the screw to be removed, thus allowing for subsequent dismantling.
- The wide range of diameters, usage lengths and head shapes provides the correct plug for every fixing.

Characteristics



INOX STAINLESS STEEL

Building materials

- Concrete
- Solid sand-lime brick
- Building brick
- Natural stone
- Solid brick made from lightweight concrete
- Aerated concrete
- Solid panel made from gypsum
- Vertically perforated brick
- Perforated sand-lime brick
- Hollow blocks made from lightweight concrete

Functioning

- The Hammerfix N is suitable for push-through installation.
- When hammered in, the nail screw causes the plug to expand in two directions, thus providing a secure anchoring in the building material.
- Countersunk head plugs are recommended for the installation of timber constructions; in the case of metal constructions, use plugs with cylindrical head, and use flat edge plugs for long holes.

Versions

- Zinc-plated steel
- Stainless steel

Installation N

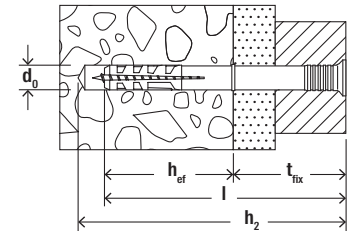
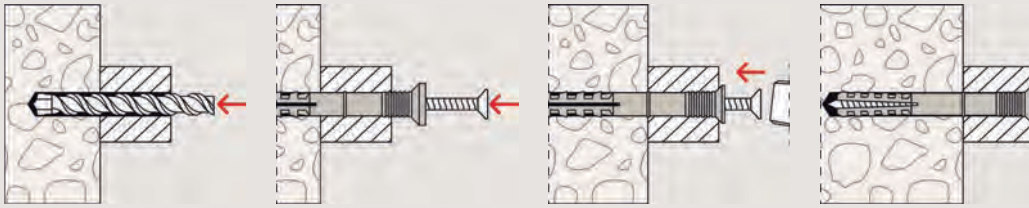

Technical data

Hammerfix N-S



N-S with nail

N-S A2 with stainless steel A2 nail

Item	Zinc-plated steel	Stainless steel A2	Drill hole diameter	Effect. anchorage depth	Anchor length	Min. drill hole depth for through fixings	Max. fixture thickness	Drive	Sales unit [pcs]
	Item No.	Item No.	d_0 [mm]	h_{ef} [mm]	l [mm]	h_2 [mm]	t_{fix} [mm]		
N 5 x 30/5 S (100)	050395 ²⁾	050370	5	25	30	45	5	PZ2	100
N 5 x 40/15 S (100)	050351	—	5	25	40	55	15	PZ2	100
N 5 x 50/25 S (100)	050352	—	5	25	50	65	25	PZ2	100
N 6 x 40/10 S (50)	050354	050372	6	30	40	55	10	PZ2	50
N 6 x 40/10 S (100)	048788	—	6	30	40	55	10	PZ2	100
N 6 x 40/10 S (200)	513834 ²⁾	—	6	30	40	55	10	PZ2	200
N 6 x 60/30 S (50)	050355	050373	6	30	60	75	30	PZ2	50
N 6 x 60/30 S (100)	048789	—	6	30	60	75	30	PZ2	100
N 6 x 60/30 S (200)	513835 ²⁾	—	6	30	60	75	30	PZ2	200
N 6 x 80/50 S (50)	050353	—	6	30	80	95	50	PZ2	50
N 6 x 80/50 S (100)	048790	—	6	30	80	95	50	PZ2	100
N 6 x 80/50 S (200)	513836 ²⁾	—	6	30	80	95	50	PZ2	200
N 8 x 60/20 S (50)	050356	050374	8	40	60	75	20	PZ3	50
N 8 x 60/20 S (100)	048791	—	8	40	60	75	20	PZ3	100
N 8 x 80/40 S (50)	050358	050375	8	40	80	95	40	PZ3	50
N 8 x 80/40 S (100)	048792	—	8	40	80	95	40	PZ3	100
N 8 x 100/60 S (50)	050357	050376	8	40	100	115	60	PZ3	50
N 8 x 100/60 S (100)	048793	—	8	40	100	115	60	PZ3	100
N 8 x 120/80 S (50)	050359	—	8	40	120	135	80	PZ3	50
N 8 x 120/80 S (100)	048794	—	8	40	120	135	80	PZ3	100
N 10 x 100/50 S (50)	050346 ¹⁾	—	10	50	100	115	50	PZ3	50
N 10 x 135/85 S (50)	050347 ¹⁾	—	10	50	135	150	85	PZ3	50
N 10 x 160/110 S (50)	050348 ¹⁾	—	10	50	160	175	110	PZ3	50
N 10 x 230/180 S (50)	050335 ¹⁾	—	10	50	230	245	180	PZ3	50

1) not pre-assembled

2) also specially suitable for fischer pipe clips FC, see chapter electrical fixings.

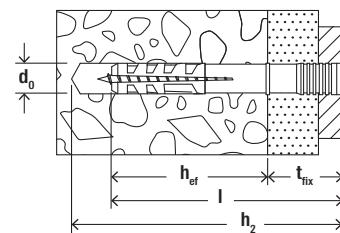

Technical data

Hammerfix N-F



N-F with cylindrical head and nail

5

Item	Item No. gvz	Drill hole diameter	Effect. anchorage depth	Anchor length	Min. drill hole depth for through fixings	Max. fixture thickness	Drive	Sales unit
		d_0 [mm]	h_{ef} [mm]	l [mm]	h_2 [mm]	t_{fix} [mm]		[pcs]
N 5 x 25/1 F (100)	514872	5	25	25	40	1	PZ2	100
N 5 x 25/1 F (200)	514873	5	25	25	40	1	PZ2	200
N 5 x 30/5 F (100)	513736	5	25	30	45	5	PZ2	100
N 5 x 30/5 F (200)	513739	5	25	30	45	5	PZ2	200
N 5 x 40/15 F (100)	513737	5	25	40	55	15	PZ2	100
N 5 x 40/15 F (200)	513740	5	25	40	55	15	PZ2	200
N 5 x 50/25 F (100)	513738	5	25	50	65	25	PZ2	100
N 5 x 50/25 F (200)	513741	5	25	50	65	25	PZ2	200
N 6 x 35/5 F (100)	522948	6	30	35	40	5	PZ2	100
N 6 x 40/10 F (100)	513840	6	30	40	55	10	PZ2	100
N 6 x 40/10 F (200)	513843	6	30	40	55	10	PZ2	200
N 6 x 60/30 F (100)	513841	6	30	60	75	30	PZ2	100
N 6 x 60/30 F (200)	513844	6	30	60	75	30	PZ2	200
N 6 x 80/50 F (100)	513842	6	30	80	95	50	PZ2	100
N 6 x 80/50 F (200)	513845	6	30	80	95	50	PZ2	200
N 8 x 60/20 F (100)	513701	8	40	60	75	20	PZ3	100
N 8 x 80/40 F (100)	513702	8	40	80	95	40	PZ3	100
N 8 x 100/60 F (100)	513703	8	40	100	115	60	PZ3	100
N 8 x 120/80 F (100)	513704	8	40	120	135	80	PZ3	100

Technical data

Hammerfix N-PK/-S M/-S D A2



N-P K with flat edge and plastic nail



N-S M with nail and connection thread M6



N-S D A2 with isolating washer and nail

Item	Item No. gvz	Drill hole diameter	Effect. anchorage depth	Anchor length	Max. fixture thickness	Min. drill hole depth for through fixings	Washer	Drive	Sales unit
		d_0 [mm]	h_{ef} [mm]	l [mm]	t_{fix} [mm]	h_2 [mm]	[Ø mm]		[pcs]
N 6 x 40/7 P K (50)	050342	6	30	40	7	55	—	—	50
N 6 x 40/10 S M6 (50)	050398	6	30	40	10	55	—	—	50
N 6 x 40/10 S D A2 (50)	050367	6	30	40	10	55	19	PZ2	50
N 6 x 60/30 S D A2 (50)	050368	6	30	60	30	75	19	PZ2	50

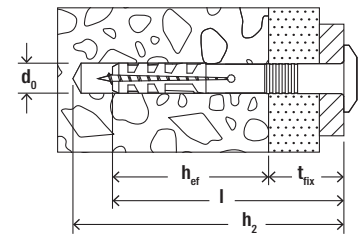

Technical data

Hammerfix N-P



N-P with flat edge and nail

N-P A2 with flat edge and stainless steel A2 nail

Item	Zinc-plated steel	Stainless steel A2	Drill hole diameter	Effect. anchorage depth	Anchor length	Min. drill hole depth for through fixings	Max. fixture thickness	Drive	Sales unit
	Item No.	Item No.	d_0 [mm]	h_{ef} [mm]	l [mm]	h_2 [mm]	t_{fix} [mm]		[pcs]
N 5 x 30/5 P (100)	050338	—	5	25	30	45	5	PZ2	100
N 6 x 30/1 P (100)	514869	—	6	30	30	45	1	PZ2	100
N 6 x 40/7 P (50)	050339	050369	6	30	40	55	7	PZ2	50
N 6 x 40/7 P (100)	048795	—	6	30	40	55	7	PZ2	100
N 6 x 40/7 P (200)	514871	—	6	30	40	55	7	PZ2	200
N 8 x 40/1 P (50)	015903	—	8	40	40	55	1	PZ3	50
N 8 x 40/1 P (100)	514870	—	8	40	40	55	1	PZ3	100

Loads

Hammerfix N

Recommended loads¹⁾ for a single anchor.

The given loads are valid for screw nails with the specified diameter.

Type		N 5	N 6 ³⁾	N 8	N 10
Screw nail diameter	[mm]	3.5	4	5	7
Recommended loads in the respective base material F_{rec} ²⁾					
Concrete	\geq C20/25	[kN] 0.20	0.25	0.27	0.33
Solid brick	\geq Mz 12	[kN] 0.14	0.18	0.24	0.30
Solid sand-lime brick	\geq KS 12	[kN] 0.18	0.22	0.24	0.33
Solid brick of lightweight aggregate concrete	\geq V 4	[kN] 0.05	0.12	0.15	0.16
Aerated concrete	\geq AAC 2	[kN] 0.03	0.04	0.05	0.10
Aerated concrete	\geq AAC 4	[kN] 0.07	0.10	0.13	0.16

¹⁾ Required safety factors are considered.

²⁾ Valid for tensile load, shear load and oblique load under any angle.

³⁾ The values have to be reduced by 50% for N 6 x 40/7 P K.

Hammerfix N Green

The hammer-in plug for simple, fast and economic installation



Cable fixing



Timber substructures

5

Applications

- Substructures made of wood and metal
- Wall connection or plaster profiles
- Slides
- Sheets
- Cable and pipe clips
- Perforated tapes

Advantages

- Produced with at least 50% renewable raw materials and therefore particularly environmentally friendly.
- Just as effective, secure and durable as regular hammerfix N plugs.
- The rapid push-through and hammer-set installation reduces the amount of work required and allows for economic series

installation.

- The integrated hammer-in stop prevents the plug from expanding prematurely, thus enabling problem-free installation.
- Together with the cross-slot recess, the thread of the nail screw allows the screw to be removed, thus allowing for subsequent dismantling.

Characteristics



Building materials

- Concrete
- Solid sand-lime brick
- Building brick
- Natural stone
- Solid brick made from lightweight concrete
- Aerated concrete
- Solid panel made from gypsum
- Vertically perforated brick
- Perforated sand-lime brick
- Hollow blocks made from lightweight concrete

Functioning

- The hammerfix N Green is suitable for push-through installation.
- The easiest installation: drill, knock in and you're done.
- When being hammered in, the nail screw causes the plug to expand in two directions, thus providing a secure anchoring in the building material.

Installation N Green

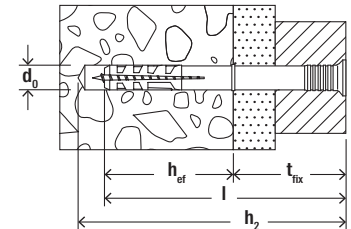
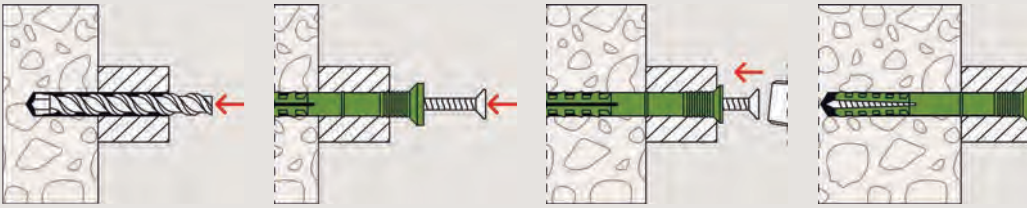

5

Technical data

Hammerfix N Green



N Green S with countersunk head and zinc-plated nail

Item	Item No.	Drill hole diameter	Effect. anchorage depth	Anchor length	Min. drill hole depth for through fixings	Max. fixture thickness	Drive	Sales unit
		d_0 [mm]	h_{ef} [mm]	l [mm]	h_2 [mm]	t_{fix} [mm]		[pcs]
N Green 6 x 40/10 S	524845	6	30	40	55	10	PZ2	45
N Green 6 x 60/30 S	524847	6	30	60	75	30	PZ2	45
N Green 6 x 80/50 S	524848	6	30	80	95	50	PZ2	45
N Green 8 x 80/40 S	524849	8	40	80	95	40	PZ3	45
N Green 8 x 100/60 S	524850	8	40	100	115	60	PZ3	45

Loads

Hammerfix N Green

Recommended loads¹⁾ for a single anchor.

The given loads are valid for screw nails with the specified diameter.

Type		N Green 6	N Green 8
Screw nail diameter	[mm]	4	5
Recommended loads in the respective base material $F_{rec}^{2)}$			
Concrete	$\geq C20/25$	[kN] 0.25	0.27
Solid brick	$\geq Mz 12$	[kN] 0.18	0.24
Solid sand-lime brick	$\geq KS 12$	[kN] 0.22	0.24
Solid brick of lightweight aggregate concrete	$\geq V 4$	[kN] 0.12	0.15
Aerated concrete	$\geq AAC 2$	[kN] 0.04	0.05
Aerated concrete	$\geq AAC 4$	[kN] 0.10	0.13

¹⁾ Required safety factors are considered.

²⁾ Valid for tensile load, shear load and oblique load under any angle.

Nail sleeve FNH

The user-friendly spring sleeve for light fixings in solid building materials

5



Timber substructures

Applications

- Squared timbers
- Substructures made of wood and metal
- Metal profiles

Advantages

- No plugs or screws are required for the one-piece nail sleeve. This guarantees a simple and easy installation.
- The geometry of the nail sleeve makes

it easy to push it into the drill hole. This saves time and money.

Building materials

- Concrete
- Solid sand-lime brick
- Natural stone with dense structure
- Solid brick

Functioning

- The FNH nail sleeve is suitable for push-through installation.
- The nail sleeve is hammered in and expands its entire length in the hole.
- FNH is suitable for interior applications and for temporary external fixings.

Installation FNH

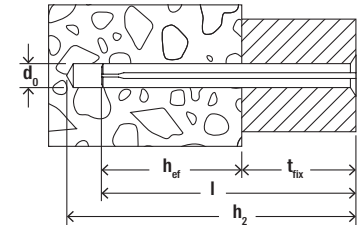
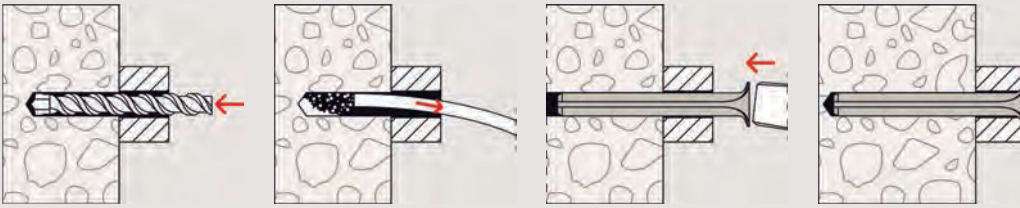

5

Technical data

Nail sleeve FNH



FNH

Item	Item No.	Drill hole diameter	Effect. anchorage depth	Anchor length	Max. fixture thickness	Min. drill hole depth for through fixings	Sales unit [pcs]
		d_0 [mm]	h_{ef} [mm]	l [mm]	t_{fix} [mm]	h_2 [mm]	
FNH 5/50	541893	5	20	50	30	60	100
FNH 6/30	541894	6	30	30	—	40	100
FNH 6/40	541895	6	30	40	10	50	100
FNH 6/50	541896	6	30	50	20	60	100
FNH 6/60	541897	6	30	60	30	70	100
FNH 6/80	541898	6	30	80	50	90	100
FNH 8/70	541899	8	40	70	30	80	100
FNH 8/90	541905	8	40	90	50	100	50
FNH 8/110	541906	8	40	110	70	120	50
FNH 8/130	541907	8	40	130	90	140	50
FNH 8/150	541908	8	40	150	110	160	50
FNH 8/180	541909	8	40	180	140	190	50

Loads

Nail sleeve FNH

Recommended loads¹⁾ of a single anchor as part of a multiple fixing of non-structural systems.

Type		FNH 5	FNH 6	FNH 8
Minimum member thickness	[mm]	50	60	70
Anchorage in concrete \geq C20/25				
Recommended tension load N_{rec}	[kN]	0.10	0.50	0.70
Recommended shear load V_{rec}	[kN]	0.40	1.40	2.00

¹⁾ Required safety factors are considered.

Window frame fixing F-S

The nylon fixing for stress-free stand-off installation of window and door frames



Window frames

5

Applications

- Window frames
- Door frames

Advantages

- The operating principle of the plug prevents the frame from being pulled against the substrate, and ensures a stress-free and long-lasting fixing of the frame.
- The special plug geometry anchors the metal and plastic profiles against com-

pressive and tensile loads, and allows for a secure hold of the window frame.

- The cover cap (available separately) can be used to discreetly cover the screw head.

Certificates



Building materials

- Concrete
- Vertically perforated brick
- Hollow blocks made from lightweight concrete
- Perforated sand-lime brick
- Solid sand-lime brick
- Aerated concrete
- Solid brick made from lightweight concrete
- Solid brick

Functioning

- The F-S is suitable for push-through installation.
- By tightening the screw, the glass-fibre-reinforced plastic cone is drawn into the sleeve, whereby it is expanded and wedged inside the drill hole. The window frames are thus fixed in a stress-free manner.
- The maximum installation torque is 3 Nm for F 8 S and 6 Nm for F 10 S.

Installation F-S

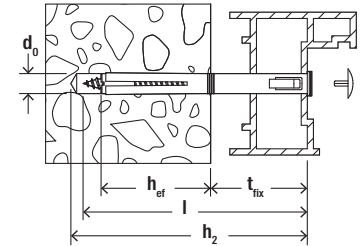
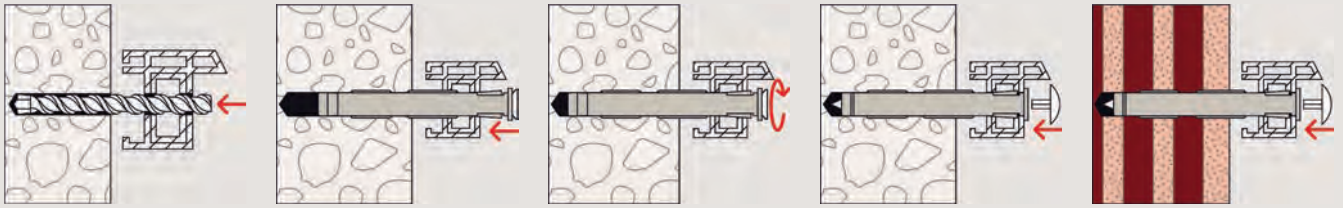

5

Technical data

Window frame fixing F-S



F-S - with zinc-plated countersunk screw and cross drive Z3

Item	Item No.	Drill hole diameter	Effect. anchorage depth	Anchor length	Max. fixture thickness	Min. drill hole depth for through fixings	Max. installation torque	Sales unit
		d_0 [mm]	h_{ef} [mm]	l [mm]	t_{fix} [mm]	h_2 [mm]	T_{inst} [Nm]	[pcs]
F 10 S 75	088625	10	50	75	15	90	6	50
F 10 S 100	088626	10	50	100	40	115	6	50
F 10 S 120	088627	10	50	120	60	135	6	50
F 10 S 140	088628	10	50	140	80	155	6	50
F 10 S 165	088629	10	50	165	105	180	6	50

Accessories

Cover cap ADF (F-S)



ADF

Item	Item No.	Diameter	Colour	Sales unit
		d [mm]		[pcs]
ADF 12 W	060275	12	white	100

Loads

Window frame F-S			
Recommended loads ¹⁾ of a single anchor as part of a multiple fixing of non-structural systems.			
Type		F 8 S	F 10 S
Recommended loads in the respective base material $F_{rec}^{2)}$			
Concrete	≥ C20/25	[kN] 0.78	1.48
Solid brick	≥ Mz 12	[kN] 0.90	1.25
Solid sand-lime brick	≥ KS 12	[kN] 0.90	1.25
Solid brick of lightweight aggregate concrete	≥ V 2	[kN] 0.25	-
Perforated sand-lime brick	≥ KSL 6	[kN] 0.25	-

¹⁾ Required safety factors are considered.

²⁾ Valid for tensile load, shear load and oblique load under any angle.

Metal frame fixing F-M

The fixing for stress-free installation of window and door frames with fire classification



Fire protection doors

Applications

- Window frames
- Door frames
- Squared timbers

Certificates



Fire resistance classification
R120

Advantages

- The F-M metal frame plug achieves fire resistance R 120. This allows for use in areas where fire resistance is relevant.
- The operating principle prevents the window frame from being pulled against the substrate, and ensures a stress-free and long-lasting fixing of the frame.
- The special plug geometry anchors the

metal and plastic profiles against compressive and tensile loads, and allows for a secure hold of the window frame.

- The cover caps (available separately) can be used to discreetly cover the screw heads.

Building materials

- Concrete
- Vertically perforated brick
- Hollow blocks made from lightweight concrete
- Perforated sand-lime brick
- Solid sand-lime brick
- Aerated concrete
- Solid brick made from lightweight concrete
- Solid brick

Functioning

- The F-M is suitable for push-through installation.
- By tightening the screw, the cone is drawn into the sleeve and the fixing is expanded which wedges it inside the drill hole. The window frames are thus fixed in a stress-free manner.
- The maximum installation torque is 5 Nm.

Installation F-M

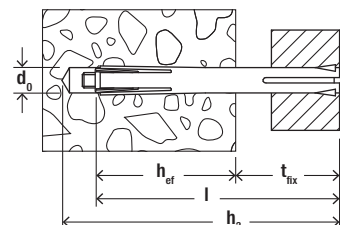
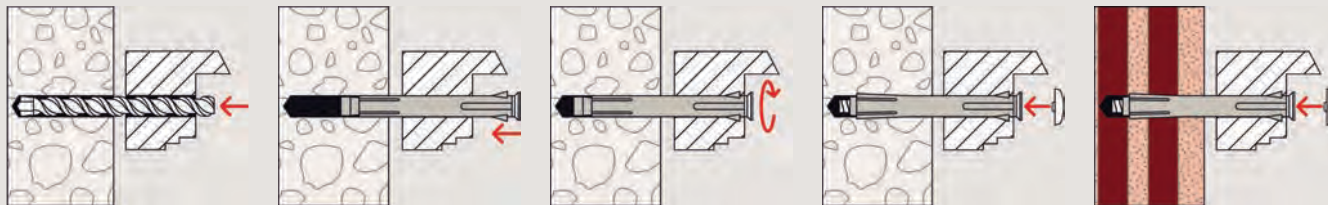

5

Technical data

Metal frame fixing F-M



F 8 M - with zinc-plated raised countersunk screw and cross drive PZ2

Item	Item No.	Drill hole diameter d_0 [mm]	Min. drill hole depth for through fixings h_2 [mm]	Effect. anchorage depth h_{ef} [mm]	Anchor length l [mm]	Max. fixture thickness t_{fix} [mm]	Drive	Sales unit [pcs]
F 8 M 72	088660 ¹⁾	8	90	30	72	42	PZ2	100
F 8 M 92	088662 ¹⁾	8	110	30	92	62	PZ2	100
F 8 M 112	088664 ¹⁾	8	130	30	112	82	PZ2	100
F 8 M 132	088666 ¹⁾	8	150	30	132	102	PZ2	100

1) Screw head \varnothing 10 mm

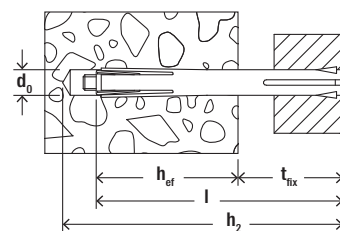

Technical data

Metal frame fixing F-M



F 10 M - with zinc-plated countersunk head screw and cross drive PZ3

Item	Item No.	Drill hole diameter d_0 [mm]	Min. drill hole depth for through fixings h_2 [mm]	Effect. anchorage depth h_{ef} [mm]	Anchor length l [mm]	Max. fixture thickness t_{fix} [mm]	Drive	Sales unit [pcs]
F 10 M 72	088670 ¹⁾	10	90	30	72	42	PZ3	100
F 10 M 92	088672 ¹⁾	10	110	30	92	62	PZ3	100
F 10 M 112	088674 ¹⁾	10	130	30	112	82	PZ3	100

1) Screw head \varnothing 13 mm

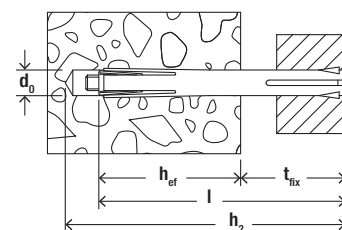

Technical data

Metal frame fixing F-M



F 10 M - with zinc-plated countersunk head screw and cross drive PZ3

Item	Item No.	Drill hole diameter d_0 [mm]	Min. drill hole depth for through fixings h_2 [mm]	Effect. anchorage depth h_{ef} [mm]	Anchor length l [mm]	Max. fixture thickness t_{fix} [mm]	Drive	Sales unit [pcs]
F 10 M 132	088676 ¹⁾	10	150	30	132	102	PZ3	100
F 10 M 152	088678 ¹⁾	10	170	30	152	122	PZ3	100
F 10 M 182	088680 ¹⁾	10	200	30	182	152	PZ3	50
F 10 M 202	061064 ¹⁾	10	220	30	202	172	PZ3	50

¹⁾ Screw head \varnothing 13 mm

Accessories

Cover cap (F-M)



ADM 10 W

Item	Item No.	Colour	Cap height [mm]	Cap [\varnothing mm]	Match	Sales unit [pcs]
ASM 10 W	060320	white	3	15	F 10 M	100
ADM 10 W	088688	white	4	16,5	F 10 M	100

Loads

Metal frame fixing F-M

Recommended loads¹⁾ of a single anchor as part of a multiple fixing of non-structural systems.

Type		F 8 M	F 10 M
Recommended loads in the respective base material F_{rec} ²⁾			
Concrete	\geq C20/25	[kN] 1.00	1.40
Solid brick	\geq Mz 12	[kN] 0.30	1.30
Solid sand-lime brick	\geq KS 12	[kN] 0.70	1.30
Solid brick of lightweight aggregate concrete	\geq V 2	[kN] -	0.50
Perforated sand-lime brick	\geq KSL 6	[kN] 0.25	0.60

¹⁾ Required safety factors are considered.

²⁾ Valid for tensile load, shear load and oblique load under any angle.

Window frame screws FFSZ and FFS

The economical special screw for window installation

5



Window frames

Applications

- Window frames made of wood, plastic and aluminium
- Door frames
- Squared timbers

Advantages

- Screw installation without plug for economical processing.
- The small drill bit diameter of 6 mm allows for efficient series installation.
- The continuous thread ensures a stress-free fixing of the frame in the substrate.
- The high-low-thread at the screw tip as well as several cutting notches reduce the amount of force required for screwing

in the screws. The installation process can be completed without excessive effort.

- With two head types applicable for all common frame materials.
- According to the ift Rosenheim suitable for the fixation of a plastic window in brick masonry.

Certificates



Test Report No.: 14-000559-PR02

Building materials

- Concrete
- Vertically perforated brick
- Hollow blocks made from lightweight concrete
- Perforated sand-lime brick
- Solid sand-lime brick
- Solid brick made from lightweight concrete
- Solid brick
- Aerated concrete

Functioning

- Note the drill hole and screw-in depths for the different building materials listed in the table.
- Cylinder head screws are recommended for recessed installation in wooden profiles.
- Flat head screws are recommended for installation in plastic and aluminium profiles.

Installation FFSZ

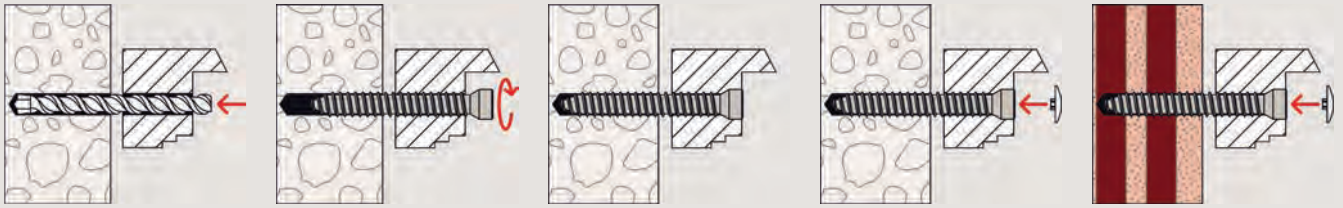

Installation FFS

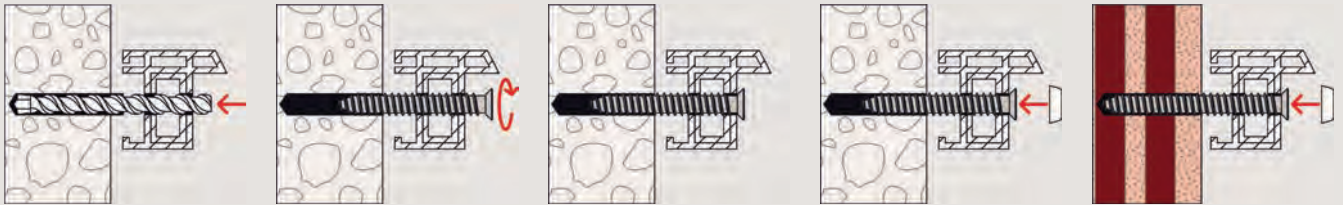

5

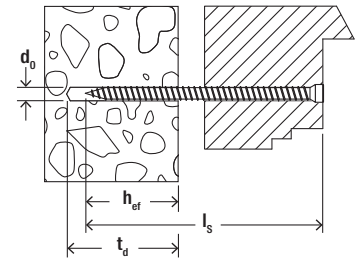

Anchorage depth h_{ef}
 $h_{ef} \geq 30$ mm in concrete
 $h_{ef} \geq 40$ mm in solid brick
 $h_{ef} \geq 60$ mm in perforated brick / aerated concrete

t_d : drill hole depth $\geq h_{ef} + 10$ mm

Technical data

Window frame screws FFSZ



FFSZ with cylinder head

Item	Item No.	Drill hole diameter d_0 [mm]	Screw length l_s [mm]	Drive	Head [Ø mm]	Sales unit [pcs]
FFSZ 7,5 x 52 T30	532906	6	52	T30	8	100
FFSZ 7,5 x 62 T30	532907	6	62	T30	8	100
FFSZ 7,5 x 72 T30	532908	6	72	T30	8	100
FFSZ 7,5 x 82 T30	532909	6	82	T30	8	100
FFSZ 7,5 x 92 T30	532910	6	92	T30	8	100
FFSZ 7,5 x 102 T30	532911	6	102	T30	8	100
FFSZ 7,5 x 112 T30	532912	6	112	T30	8	100
FFSZ 7,5 x 122 T30	532913	6	122	T30	8	100
FFSZ 7,5 x 132 T30	532914	6	132	T30	8	100
FFSZ 7,5 x 152 T30	532915	6	152	T30	8	100
FFSZ 7,5 x 182 T30	532916	6	182	T30	8	100
FFSZ 7,5 x 202 T30	532917	6	202	T30	8	100
FFSZ 7,5 x 212 T30	532919	6	212	T30	8	100
FFSZ 7,5 x 252 T30	532920	6	252	T30	8	100
FFSZ 7,5 x 302 T30	532921	6	302	T30	8	100

No pre-drilling in aerated concrete.

Accessories

Cover cap FFSZ-A



FFSZ-A

Item	Item No.	Colour	Cap [Ø mm]	Cap height [mm]	Match	Sales unit [pcs]
FFSZ-A W	538708	white	14	2,2	FFSZ - cylinder head	100
FFSZ-A BR	538709	brown	14	2,2	FFSZ - cylinder head	100

5

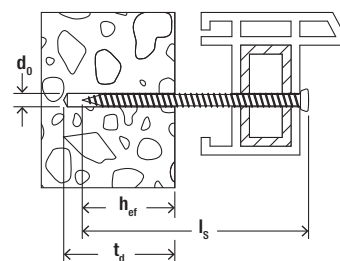

Anchorage depth h_{ef}
 $h_{ef} \geq 30$ mm in concrete
 $h_{ef} \geq 40$ mm in solid brick
 $h_{ef} \geq 60$ mm in perforated brick / aerated concrete

t_d : drill hole depth $\geq h_{ef} + 10$ mm

Technical data

Window frame screws FFS



FFS with flat head

Item	Item No.	Drill hole diameter d_0 [mm]	Screw length l_s [mm]	Drive	Head [Ø mm]	Sales unit [pcs]
FFS 7,5 x 42 T30	532922	6	42	T30	11,5	100
FFS 7,5 x 52 T30	532923	6	52	T30	11,5	100
FFS 7,5 x 62 T30	532925	6	62	T30	11,5	100
FFS 7,5 x 72 T30	532927	6	72	T30	11,5	100
FFS 7,5 x 82 T30	532928	6	82	T30	11,5	100
FFS 7,5 x 92 T30	532930	6	92	T30	11,5	100
FFS 7,5 x 102 T30	532931	6	102	T30	11,5	100
FFS 7,5 x 112 T30	532932	6	112	T30	11,5	100
FFS 7,5 x 122 T30	532934	6	122	T30	11,5	100
FFS 7,5 x 132 T30	532935	6	132	T30	11,5	100
FFS 7,5 x 152 T30	532941	6	152	T30	11,5	100
FFS 7,5 x 182 T30	532942	6	182	T30	11,5	100
FFS 7,5 x 202 T30	532943	6	202	T30	11,5	100
FFS 7,5 x 212 T30	532944	6	212	T30	11,5	100
FFS 7,5 x 252 T30	532945	6	252	T30	11,5	100
FFS 7,5 x 302 T30	532946	6	302	T30	11,5	100

Accessories

Cover cap FFS-A



FFS-A

Item	Item No.	Colour	Cap [Ø mm]	Cap height [mm]	Match	Sales unit [pcs]
FFS-A W	061560	white	15	4,8	FFS - flat head	100
FFS-A BR	061561	brown	15	4,8	FFS - flat head	100

Loads

5

Window frame screws FFSZ and FFS

Recommended loads¹⁾ of a single screw.

Type		FFSZ			FFS			
Screw diameter		[mm]	7.5			7.5		
Anchorage depth	$h_{ef} \geq$	[mm]	30	40	60	30	40	60
Recommended loads in concrete \geq C20/25								
Tension load N_{rec}		[kN]	1.00	-	-	1.00	-	-
Shear load V_{rec}		[kN]	0.70	-	-	0.70	-	-
Minimum edge distance ²⁾	c_{min}	[mm]	30	-	-	30	-	-
Recommended loads in masonry								
Tension load N_{rec} in solid brick	\geq Mz 12	[kN]	-	0.40 ³⁾	0.80	-	0.40 ³⁾	0.80
Shear load V_{rec} in solid brick	\geq Mz 12	[kN]	-	0.30 ³⁾	0.70	-	0.30 ³⁾	0.70
Tension load N_{rec} in solid sand-lime brick	\geq KS 12	[kN]	-	1.00	-	-	1.00	-
Shear load V_{rec} in solid sand-lime brick	\geq KS 12	[kN]	-	0.60	-	-	0.60	-
Tension load N_{rec} in vertically perforated brick	\geq Hlz 12	[kN]	-	-	0.25 ³⁾	-	-	0.25 ³⁾
Shear load V_{rec} in vertically perforated brick	\geq Hlz 12	[kN]	-	-	0.40 ³⁾	-	-	0.40 ³⁾
Minimum edge distance ²⁾	c_{min}	[mm]	-	40	40	-	40	40
Recommended loads in aerated concrete								
Load ⁴⁾ F_{rec} in aerated concrete	\geq AAC 2	[kN]	-	-	0.10 ⁵⁾	-	-	0.10 ⁵⁾
	\geq AAC 4	[kN]	-	-	0.25 ⁵⁾	-	-	0.25 ⁵⁾
Minimum edge distance ²⁾	c_{min}	[mm]	-	-	40	-	-	40

¹⁾ Required safety factors are considered.As a single screw counts e.g. a screw with a spacing $s \geq 3 \times h_{ef}$ and an edge distance $c \geq 1.5 \times h_{ef}$.²⁾ Minimal possible edge distance while reducing the recommended loads.³⁾ Rotary drilling.⁴⁾ Valid for tensile load, shear load and oblique load under any angle.⁵⁾ Without pre-drilling.

Adjustable fixing S10J

The fixing for infinite adjustment of timber constructions in all standard solid building materials



Stand-off installations

5

Applications

- Substructures made of wooden battens of 20-25 mm thickness.

Certificates



Advantages

- The combination of adjustment plug and spacing screw allows for universal usage in wooden and solid building materials.
- The special operating principle of the

adjustable fixing S10J and the spacing screw allows for infinite adjustment. This saves on the use of wedges and blocks when fixing the fixture.

Building materials

- Concrete
- Wood
- Solid sand-lime brick
- Natural stone with dense structure
- Aerated concrete
- Solid panel made from gypsum
- Solid brick made from lightweight concrete
- Solid brick

Functioning

- The S10J is suitable for push-through installation.
- Once the screw has been screwed in, the fixture distance can be infinitely adjusted by modifying the rotation direction.
- For the fixing of wood on wood, e.g. in the roof truss, only use adjustment screw JS.

Installation S10J

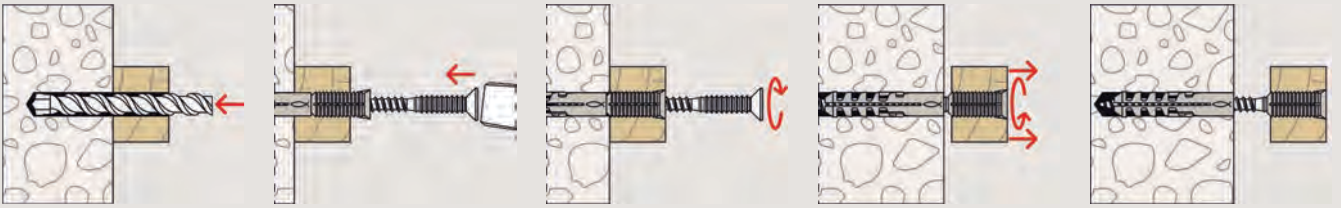

Installation JS

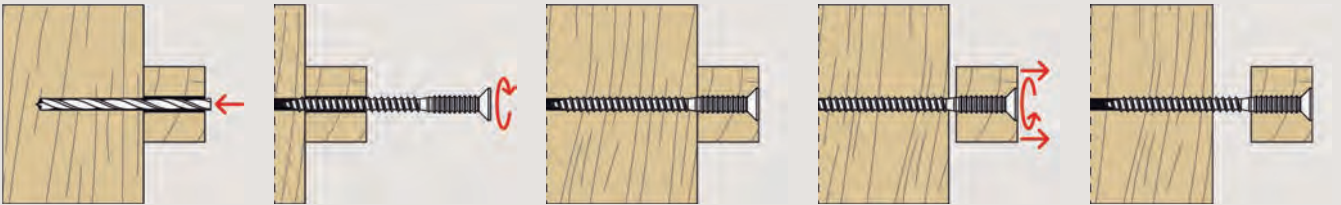

5

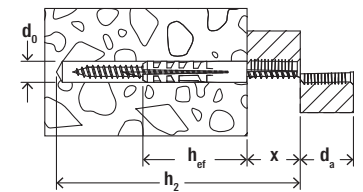

Technical data

Adjustable fixing S10J



S 10 J 75 S

Item	Item No.	Drill hole diameter d_0 [mm]	Min. drill hole depth for through fixings h_2 [mm]	Effect. anchorage depth h_{ef} [mm]	Screw length l_s [mm]	Max. timber thickness d_a [mm]	Max. adjustment travel x [mm]	Sales unit [pcs]
S 10 J 75 S	080710	10	115	50	110	25	30	50

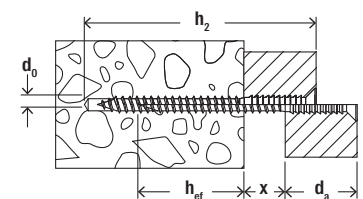

Technical data

Adjustable screw JS



JS

Item	Item No.	Drill hole diameter d_0 [mm]	Min. drill hole depth for through fixings h_2 [mm]	Effect. anchorage depth h_{ef} [mm]	Screw length l_s [mm]	Max. timber thickness d_a [mm]	Max. adjustment travel x [mm]	Sales unit [pcs]
JS 6 x 110	080700 ¹⁾	5	50 - 110	30	110	25	55	50

1) min. drill hole depth for push-through installation - depending on wood species

Adjustable screw JUSS

The adjustable screw for fast and infinitely adjustable installation of timber constructions

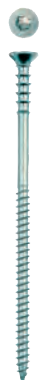

5

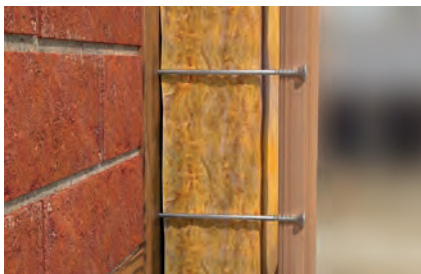

Stand-off installations



Stand-off installations

Applications

- Substructures made of wooden battens of 20-30 mm thickness.

Advantages

- The special operating principle of the adjustable screw JUSS allows for infinite adjustment. This saves on the use of wedges and blocks when fixing the

fixture.

- The self-drilling thread cuts directly into the wood. Therefore pre-drilling is not required. For the installation in hardwood pre-drilling is recommended.

Building materials

- Wood and wooden materials or wooden panels

Functioning

- The JUSS is suitable for push-through installation.
- Once the screw has been screwed in, the parallel thread below the screw head causes the fixture to initially pull against the substrate. The fixture distance can then be infinitely adjusted by modifying the rotation direction.

Installation JUSS

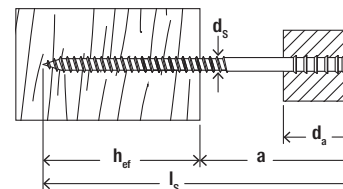
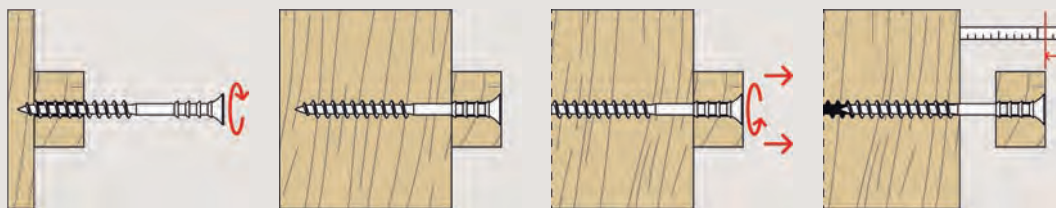

5

Technical data

Adjustable screw JUSS



JUSS

Item	Item No.	Effect. anchorage depth h_{ef} [mm]	Max. distance a [mm]	Screw $d_s \times l_s$ [mm]	Max. timber thickness d_a [mm]	Drive	Sales unit [pcs]
JUSS 6 x 60	059040	30	30	6 x 60	20	T25	100
JUSS 6 x 70	059041	30	40	6 x 70	30	T25	100
JUSS 6 x 80	059042	30	50	6 x 80	30	T25	100
JUSS 6 x 90	059043	30	60	6 x 90	30	T25	100
JUSS 6 x 100	059044	30	70	6 x 100	30	T25	100
JUSS 6 x 110	059045	30	80	6 x 110	30	T25	100
JUSS 6 x 120	059046	30	90	6 x 120	30	T25	100
JUSS 6 x 145	059047	30	115	6 x 145	30	T25	100

Spacing screw ASL

The spacing screw for flexible positioning and alignment of wooden fixtures



5



Stand-off installations



Stand-off installations

Applications

- Window frames
- Door frames
- Squared timbers
- Claddings
- Substructures made of wood

Advantages

- The coordinated threads with the same pitch allow for the pin-point positioning and alignment of the fixture, which can even be mounted at an angle to the screw. This allows for an exact and flexible fixing.
- During the installation, the fixture is not pulled onto the substrate, instead it is

brought directly to the desired distance and position. This allows for a simple and exact installation.

- When combined with SX 8 and UX 8 plugs, it can be used in almost all wall materials, guaranteeing a secure fixing.

Building materials

- Without plug: suitable for wooden materials and wooden panels
- With SX or UX plugs: all concrete and masonry materials

Functioning

- The ASL is suitable for push-through installation.
- Pre-drill the fixture at the desired angle in order to achieve the correct positioning and alignment.
- When screwing in the screw, the external thread cuts into the pre-drilled fixture, and fixes it into the stipulated position.
- The angled position of the screws (15° - 30°) allows high shear loads to be supported.

Installation ASL

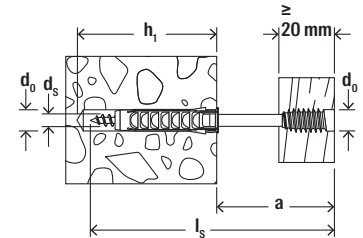
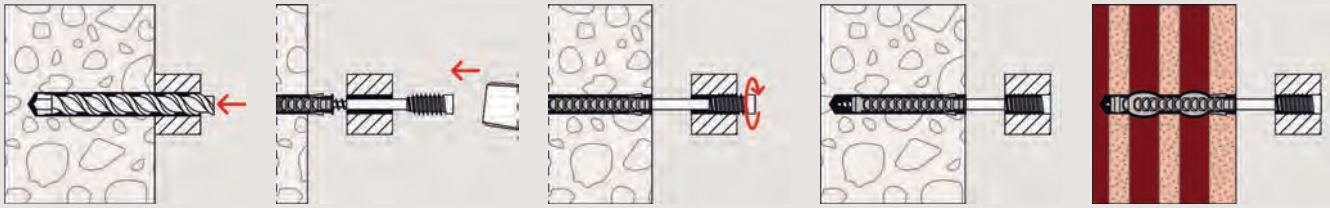

Technical data

Spacing screw ASL



ASL

Item	Item No.	Drill hole diameter d_0 [mm]	Min. drill hole depth h_1 [mm]	Max. distance a [mm]	Screw $d_s \times l_s$ [mm]	Drive	Sales unit [pcs]
ASL 4,5 x 60	059050	6	40	25	4,5 x 60	T25	100
ASL 4,5 x 80	059052	6	40	45	4,5 x 80	T25	100
ASL 4,5 x 100	059054	6	40	65	4,5 x 100	T25	100
ASL 6 x 80	059061	8	55	35	6 x 80	T25	100
ASL 6 x 100	059062	8	55	55	6 x 100	T25	100
ASL 6 x 120	059063	8	55	75	6 x 120	T25	100
ASL 6 x 150	059064	8	55	105	6 x 150	T25	50

Stand-off installation TherMax 8/10

The thermally separated stand-off installation in external thermal insulation composite systems (ETICS)



External lighting



Down pipes

5

Applications

For the thermally separated fixing of:

- Signs
- Lighting
- Letter boxes
- Motion detectors
- Downpipes
- Lightning rods
- Blind guide rails

Advantages

- The stand-off installation allows for the fixture to be adjusted to the exact position required, whereby pressure marks and damage to the ETICS are avoided.
- The plastic cone creates a thermal barrier between the fixture and the inner fixture, and offers an energy-optimised fixing.
- The glass-fibre-reinforced plastic cone cuts its own way through the ETICS with

a positive fit, and allows for a simple and fast installation without the need for any special tools.

- Combining TherMax 8 and 10 with the universal plug UX provides a secure anchoring in the substrate.
- Without UX plug direct mounting in wood substrate is possible after pre-drilling.

Building materials

- Concrete
- Vertically perforated brick
- Hollow blocks made from lightweight concrete
- Perforated sand-lime brick
- Solid sand-lime brick
- Building brick
- Aerated concrete
- Wood

Functioning

- The TherMax 8 and 10 systems are suitable for pre-positioned installation.
- The self-tapping, glass-fibre-reinforced cone cuts its own way through the plaster into the insulation during installation.
- The anti-cold cone uses a thermal barrier to minimise heat losses.
- Installation without any special tools.
- For use in wood without plug, the wood (footnote below load table) as well as the plaster has to be pre-drilled:
TherMax 8:
 $d_{02} = 14 \text{ mm}$, $h_{02} = 50 \text{ mm}$;
TherMax 10:
 $d_{02} = 18 \text{ mm}$, $h_{02} = 50 \text{ mm}$
- The extensive range features fitting options with metric screws (M6/8/10), sheet screws (6.3 mm), chipboard screws (6.0 mm) or chipboard screws (4.5 - 5.5 mm) when using an SX 5 expansion plug.

Installation in masonry

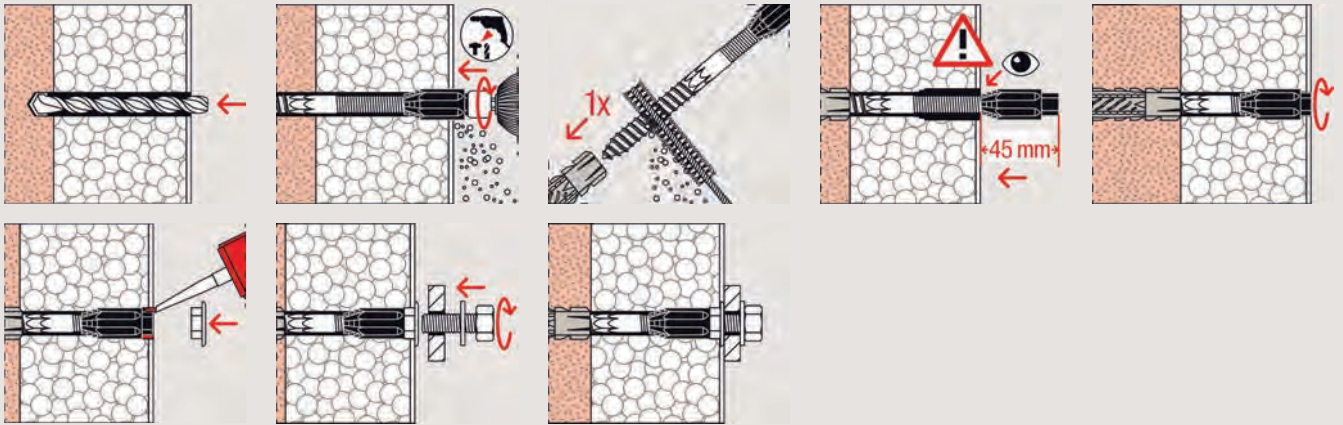

Installation in wooden substrate

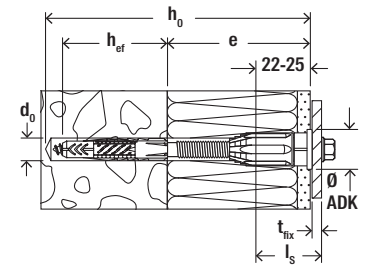
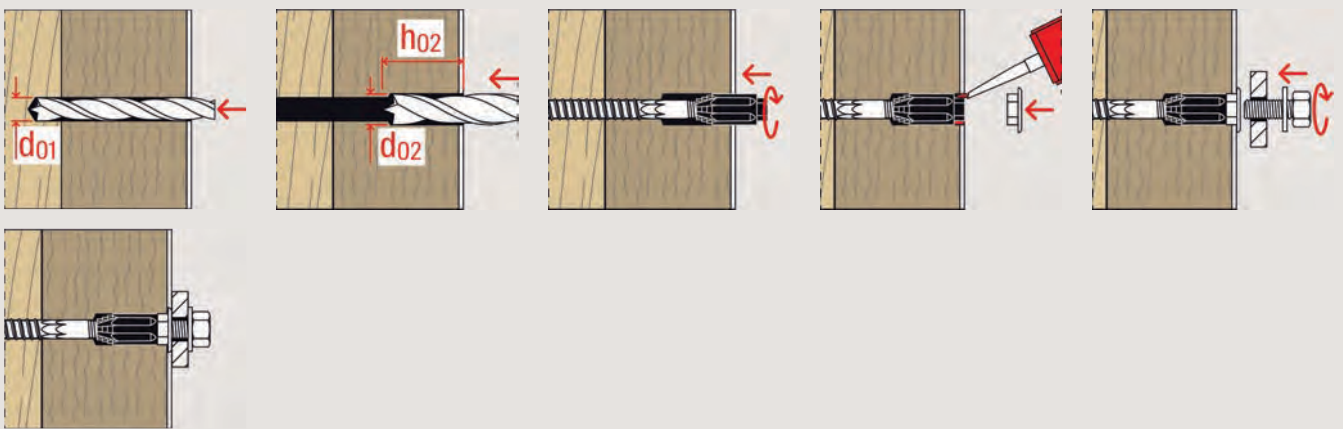

Technical data

Stand-off installation TherMax 8/10



TherMax 8 and 10

Item	Item No.	Drill hole diameter	Drill hole depth	Max. thickness of non-bearing layer	Anchorage depth	Cover cap-Ø	Width across nut	Chipboard / metric / sheet metal screw	Sales unit [pcs]
		d_0 [mm]	h_0 [mm]	e [mm]	h_{ef} [mm]	ADK [mm]	SW [mm]		
TherMax 8/60 M6	045685 ¹⁾²⁾	10	120	45 - 60	60	18	10	4,5 - 6,0 / M6 / 6,3	20
TherMax 8/80 M6	045686 ¹⁾²⁾	10	140	60 - 80	60	18	10	4,5 - 6,0 / M6 / 6,3	20
TherMax 8/100 M6	045687 ¹⁾²⁾	10	160	80 - 100	60	18	10	4,5 - 6,0 / M6 / 6,3	20

1) including SX 5

2) Min. screw length $l_s = 22\text{mm} + \text{thickness of mounting member } t_{fix}$; for use in wood without universal plug UX, consider drill hole diameter in footnote under load table.

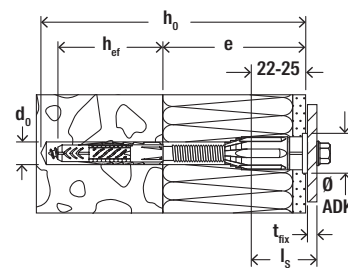

Technical data

Stand-off installation TherMax 8/10



TherMax 8 and 10

5

Item	Item No.	Drill hole diameter	Drill hole depth	Max. thickness of non-bearing layer	Anchorage depth	Cover cap-Ø	Width across nut	Chipboard / metric / sheet metal screw	Sales unit
		d_0 [mm]	h_0 [mm]	e [mm]	h_{ef} [mm]	ADK [mm]	SW [mm]		[pcs]
TherMax 8/120 M6	045688 ¹⁾²⁾	10	180	100 - 120	60	18	10	4,5 - 6,0 / M6 / 6,3	20
TherMax 8/140 M6	045689 ¹⁾²⁾	10	200	120 - 140	60	18	10	4,5 - 6,0 / M6 / 6,3	20
TherMax 8/160 M6	045690 ¹⁾²⁾	10	220	140 - 160	60	18	10	4,5 - 6,0 / M6 / 6,3	20
TherMax 8/180 M6	045691 ¹⁾²⁾	10	240	160 - 180	60	18	10	4,5 - 6,0 / M6 / 6,3	20
TherMax 10/100 M6	045692 ¹⁾²⁾	12	160	80 - 100	70	22	13	4,5 - 6,0 / M6 / 6,3	20
TherMax 10/120 M6	045693 ¹⁾²⁾	12	180	100 - 120	70	22	13	4,5 - 6,0 / M6 / 6,3	20
TherMax 10/140 M6	045694 ¹⁾²⁾	12	200	120 - 140	70	22	13	4,5 - 6,0 / M6 / 6,3	20
TherMax 10/160 M6	045695 ¹⁾²⁾	12	220	140 - 160	70	22	13	4,5 - 6,0 / M6 / 6,3	20
TherMax 10/180 M6	045696 ¹⁾²⁾	12	240	160 - 180	70	22	13	4,5 - 6,0 / M6 / 6,3	20
TherMax 10/200 M6	512605 ¹⁾²⁾	12	260	180 - 200	70	22	13	4,5 - 6,0 / M6 / 6,3	20
TherMax 10/220 M6	514250 ¹⁾²⁾	12	280	200 - 220	70	22	13	4,5 - 6,0 / M6 / 6,3	20
TherMax 10/240 M6	514251 ¹⁾²⁾	12	300	220 - 240	70	22	13	4,5 - 6,0 / M6 / 6,3	20
TherMax 10/100 M8	045697 ²⁾	12	160	80 - 100	70	22	13	M8	20
TherMax 10/120 M8	045698 ²⁾	12	180	100 - 120	70	22	13	M8	20
TherMax 10/140 M8	045699 ²⁾	12	200	120 - 140	70	22	13	M8	20
TherMax 10/160 M8	045700 ²⁾	12	220	140 - 160	70	22	13	M8	20
TherMax 10/180 M8	514252 ²⁾	12	240	160 - 180	70	22	13	M8	20
TherMax 10/200 M8	514253 ²⁾	12	260	180 - 200	70	22	13	M8	20
TherMax 10/220 M8	514254 ²⁾	12	280	200 - 220	70	22	13	M8	20
TherMax 10/240 M8	514255 ²⁾	12	300	220 - 240	70	22	13	M8	20
TherMax 10/100 M10	045702 ²⁾	12	160	80 - 100	70	22	13	M10	20
TherMax 10/120 M10	045703 ²⁾	12	180	100 - 120	70	22	13	M10	20
TherMax 10/140 M10	045704 ²⁾	12	200	120 - 140	70	22	13	M10	20
TherMax 10/160 M10	045705 ²⁾	12	220	140 - 160	70	22	13	M10	20
TherMax 10/180 M10	514256 ²⁾	12	240	160 - 180	70	22	13	M10	20
TherMax 10/200 M10	514257 ²⁾	12	260	180 - 200	70	22	13	M10	20
TherMax 10/220 M10	514258 ²⁾	12	280	200 - 220	70	22	13	M10	20
TherMax 10/240 M10	514259 ²⁾	12	300	220 - 240	70	22	13	M10	20

1) including SX 5

2) Min. screw length $l_s = 22\text{mm} + \text{thickness of mounting member } t_{\text{fix}}$; for use in wood without universal plug UX, consider drill hole diameter in footnote under load table.

Loads

Stand-off installation TherMax 8 and 10			
Recommended loads ¹⁾ of a single anchor in concrete and masonry.			
Type		TherMax 8	TherMax 10
Supplied type of plug for the anchorage in the base material		UX 10 x 60	UX 12 x 70
Recommended tensile loads in the respective base material N_{rec} ²⁾			
Concrete ^{3) 4)}	≥ C20/25	[kN] 1.00	1.00
Solid brick ³⁾⁴⁾	≥ Mz 12	[kN] 0.50	0.70
Perforated sand-lime brick ³⁾⁴⁾	≥ KSL 12	[kN] 0.60	0.80
Vertically perforated brick ⁴⁾	≥ Hlz 12	[kN] 0.20	0.30
Aerated concrete ³⁾⁴⁾	≥ AAC 4	[kN] 0.40	0.60
Recommended shear load V_{rec} , valid für all above mentioned base materials for the stated insulation thickness			
External Thermal Insulation Composite System ⁵⁾		[kN] 0.15	0.20

¹⁾ Required safety factors are considered.

²⁾ The drilling method is to be adapted to the building material used. As different joint qualities are possible, the given values only apply for installation in the brick.

³⁾ The given recommended tensile loads apply for fastenings with metric screws.

When using chipboard screws with diameter 6.0 mm they have to be reduced to 0.35 kN.

⁴⁾ The given recommended tensile loads apply for fastenings with metric screws.

When using a SX 5-plug chipboard screws with diameter 4.5 - 5.5 mm they have to be reduced to 0.1 kN.

⁵⁾ Values are valid for an ETICS made from PS- respectively PU-rigid foam panels. Thickness of rendering minimum 6 mm.

Loads

Stand-off installation TherMax 8 and 10			
Recommended shear loads ¹⁾ for a single anchor.			
Type		UX 10 + TherMax 8 ³⁾	UX 12 + TherMax 10 ³⁾
Recommended shear loads V_{rec} ¹⁾			
External thermal insulation composite system ²⁾ ≤ 240 mm		[kN] 0.15	0.20

¹⁾ Required safety factors are considered.

²⁾ Values are valid for an ETICS made from PS- respectively PU-rigid foam panels. Thickness of rendering minimum 6 mm.

³⁾ In wood installation without plug.

Loads

Stand-off installation TherMax 8 and 10			
Recommended tensile loads ¹⁾ for a single anchor in wood.			
Type		TherMax 8	TherMax 10
Recommended tensile loads in the respective base material N_{rec} ²⁾			
Beech	≥ D35	[kN] 1.00 ³⁾	1.00 ⁵⁾
Spruce	≥ C24	[kN] 1.00 ⁴⁾	1.00 ⁵⁾

¹⁾ Required safety factors are considered.

²⁾ Installation without UX-plug. Edge distances and spacings following Eurocode 5.

³⁾ Pre-drilled wood with diameter 6 mm.

⁴⁾ Pre-drilled wood with diameter 5 mm.

⁵⁾ Pre-drilled wood with diameter 7 mm.

Stand-off installation TherMax 12/16

The approved stand-off installation with thermal barrier in external thermal insulation composite systems

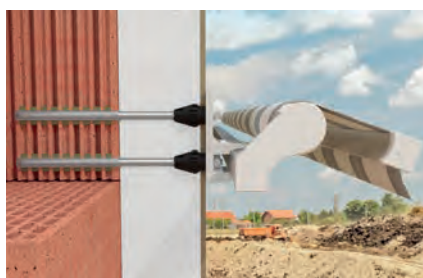

Awnings



Satellite dishes and air conditioning units

5

Applications

For the thermally separated fixing of:

- Awnings
- Canopies
- French balcony railings
- Air conditioning units
- Satellite dishes

Advantages

- When combined with the injection mortars FIS EM Plus, FIS V Plus, FIS SB and FIS GREEN, the stand-off installation is approved for high loads in a range of materials. This allows for a secure fixing.
- Usable lengths of 62 to 290 mm can be covered with just one TherMax.
- The plastic cone creates a thermal barrier

- between the fixture and the inner fixture, and offers an energy-optimised fixing.
- The glass-fibre-reinforced plastic cone cuts its own way through the ETICS with a positive fit, and allows for a simple, fast and adjustable installation without the need for any special tools.

Certificates



Building materials

Approved for:

- Concrete, cracked and non-cracked
- Vertically perforated brick
- Hollow blocks made from lightweight concrete
- Perforated sand-lime brick
- Solid sand-lime brick
- Solid brick
- Aerated concrete

Versions

- Zinc-plated steel
- Stainless steel

Functioning

- The TherMax 12 and 16 systems are suitable for pre-positioned installation.
- The self-tapping, glass-fibre-reinforced cone cuts its own way through the plaster into the insulation during installation.
- The anti-cold cone uses a thermal barrier to minimise heat losses.
- In the case of resistant plaster (e.g. thick cement plaster), it is recommended that the TherMax cutting blade included is used for grinding out the plaster.
- The sealing of the annular gap with sealing adhesive Multi MS seals the facade at plaster level.

See also

FIS EM Plus mortar page



FIS V Plus mortar page

page



FIS SB mortar 67



FIS Green mortar 114



Installation TherMax 12/16

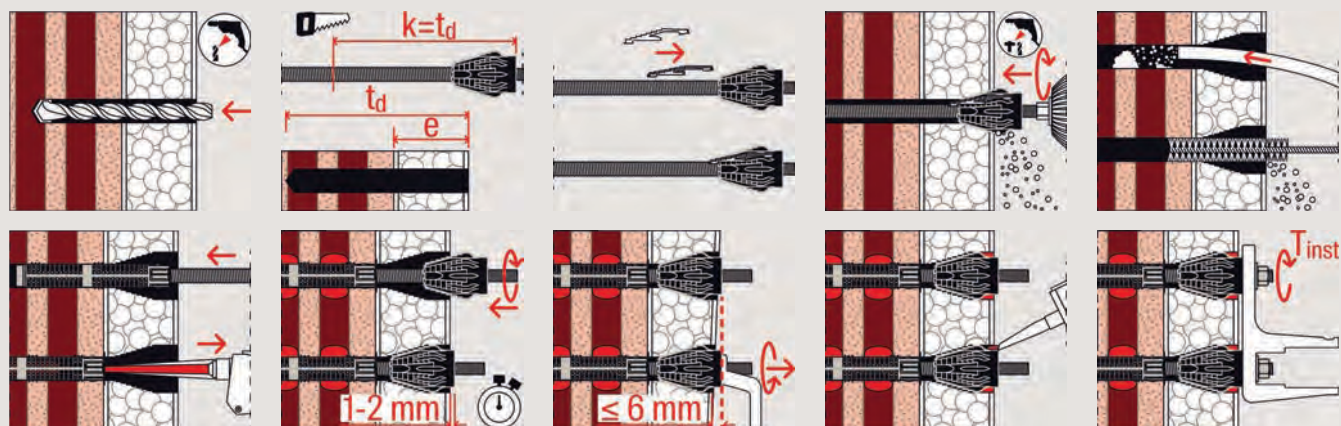

5

Technical data

Stand-off installation TherMax 12/16



TherMax 12/110 M12

TherMax 16/170 M12

Item	Zinc-plated steel	Stainless steel	Approval	Contents	Sales unit
	Item No.	Item No.			[pcs]
	gvz	R	DIBt		
TherMax 12/110 M12	051291	—	●	20 TherMax M12, 20 perforated sleeves 20 x 130, 5 bits, 5 cutting blades, 5 user manuals	20
TherMax 12/110 M12 R	—	051537	●	10 TherMax M12 R, 10 perforated sleeves 20 x 130, 3 bits, 3 cutting blades, 3 user manuals	10
TherMax 12/110 M12 (2)	051290	—	●	2 TherMax M12, 2 perforated sleeves 20 x 130, 1 bit, 1 cutting blade, 1 user manual	1
TherMax 16/170 M12	051293	—	●	20 TherMax M16, 20 perforated sleeves 20 x 200, 5 bits, 5 cutting blades, 5 applicator tip extension hoses, 5 user manuals	20
TherMax 16/170 M12 R	—	051543	●	10 TherMax M16 R, 10 perforated sleeves 20 x 200, 3 bits, 3 cutting blades, 3 applicator tip extension hoses, 3 user manuals	10
TherMax 16/170 M12 (2)	051292	—	●	2 TherMax M16, 2 perforated sleeves 20 x 200, 1 bit, 1 cutting blade, 1 applicator tip extension hose, 1 user manual	1

Installation data

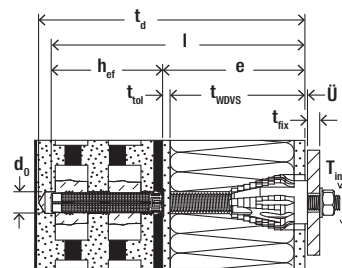

Type	Length of TherMax incl. anti-cold cone l [mm]	Building material + insulation		Suitable injection anchor sleeve	Drill hole diameter d ₀ [mm]	Min. anchorage depth h _{ef} [mm]	Drill hole depth t _d [mm]	Thickness of non-bearing layer e [mm]	Fixture Max. fixture thickness t _{fix} [mm]	Con-nection thread	Max. installation torque T _{inst} [Nm]	Required resin quantity [Scale unit]
		Threaded rod in building material	Building material									
TherMax M 12	240	M 12	Concrete	-	14	70	h _{ef} + e	62 - 170	16 ¹⁾	M 12	20	5
	240	M 12	Solid brick	-	14	80	h _{ef} + e	62 - 160	16 ¹⁾	M 12	20	6
	240	M 12	Perforated brick	FIS H 20x130 K	20	130	h _{ef} + e + 10 mm	62 - 110	16 ¹⁾	M 12	20	26
	240	M 12	Aerated concrete	-	14	100	h _{ef} + e	62 - 140	16 ¹⁾	M 12	20	8
TherMax M 16	370	M 16	Concrete	-	18	80	h _{ef} + e	62 - 290	16 ¹⁾	M 12	20	7
	370	M 16	Solid brick	-	18	80	h _{ef} + e	62 - 290	16 ¹⁾	M 12	20	7
	370	M 16	Perforated brick	FIS H 20x200 K	20	200	h _{ef} + e + 10 mm	62 - 170	16 ¹⁾	M 12	20	40
	370	M 16	Aerated concrete	-	18	100	h _{ef} + e	62 - 270	16 ¹⁾	M 12	20	9

¹⁾ The setscrews may be replaced by a setscrew / fixing screw up to a length 200 mm.

Accessories installation

Injection mortar



FIS EM Plus 390 S

FIS V Plus 360 S

FIS Green 300 T

FIS SB 390 S

Multi MS white

Item	Item No.	Approval		Languages on the cartridge	Contents	Sales unit [pcs]
		DIBt	ETA			
FIS EM Plus 390 S	544154 ¹⁾	●	●	DE, EN, FR, NL, ES, PT	1 cartridge 390 ml, 2 x FIS MR Plus	6
FIS EM Plus 390 S	544155 ¹⁾	●	●	EN, ZH, EL, KO, HU, PL	1 cartridge 390 ml, 2 x FIS MR Plus	6
FIS V Plus 360 S	558752	●	●	DE, FR, NL	1 cartridge 360 ml, 2 x FIS MR Plus	6
FIS V Plus 360 S (EN,ES,PT)	558746	●	●	EN, ES, PT	1 cartridge 360 ml, 2 x FIS MR Plus	6
FIS SB 390 S	519451	—	●	DE, FR, NL	1 cartridge 390 ml, 2 x FIS MR Plus	6
FIS SB 390 S	518831	—	●	EN, ES, PT	1 cartridge 390 ml, 2 x FIS MR Plus	6
FIS Green 300 T	522989	—	●	FR	1 cartridge 300 ml, 2 x FIS MR Plus with transparent Clip	4
FIS Green 300 T	523245	—	●	IT	1 cartridge 300 ml, 2 x FIS MR Plus with transparent Clip	12
FIS Green 300 T	538219	—	●	CS, SK	1 cartridge 300 ml, 2 x FIS MR Plus	12
FIS Green 300 T	532972	—	●	DA, SV, NO, FI	1 cartridge 300 ml, 2 x FIS MR Plus with transparent Clip	12
KD white 290ML	059389	—	—	DE, EN	1 cartridge 290 ml	12

¹⁾ Dangerous goods - no express shipping possible.

Accessories for drill hole cleaning

Brushes



BS

Item	Item No.	Length	Length	Brush diameter [mm]	For drill diameter [mm]	Sales unit [pcs]
		L ₁ [mm]	L ₂ [mm]			
BS ø 14	078180	250	80	16	14	1
BS ø 16/18	078181	250	80	20	16/18	1
BS ø 20/22	052277	180	80	25	20/22	1

Accessories for drill hole cleaning

Blow-out pump



AB G

Item	Item No.	Sales unit [pcs]
Blow-out pump AB G	089300	1

Accessories

Accessories



TherMax cutting blade

TherMax thread reducing pin

Item	Item No.	Description	Sales unit [pcs]
TherMax cutting blade, 25 pcs	547723	for milling the thermal insulation with a resistant plaster	1
TherMax thread reducing pin M12/M10 A4	553834	enables a connection thread M10	10

Loads

Stand-off installation TherMax 12 and 16 with load-bearing anchor rod made of zinc-plated steel 8.8 and a displacement of 1 mm

The below load table is valid for short-term loading (e.g. wind load). If the sealing of the annular gap between TherMax and plaster is assured by fischer all-round sealing KD, the TherMax version with an anchor rod on base substrate side made of zinc-plated steel may be used.

Highest permissible loads¹⁾⁵⁾⁷⁾ of a TherMax within an anchor group²⁾ in concrete with the injection mortars FIS V Plus or FIS SB and in masonry with the injection mortar FIS V Plus.

Type	Minimum effective anchorage depth $h_{ef}^{4)8)}$ [mm]	Permissible tensile load $N_{perm}^{3)}$ [kN]	Permissible shear load at $e = 62$ mm $V_{perm}^{3)}$ [kN]	Permissible shear load at $e = 100$ mm $V_{perm}^{3)}$ [kN]	Permissible shear load at $e = 120$ mm $V_{perm}^{3)}$ [kN]	Permissible shear load at $e = 140$ mm $V_{perm}^{3)}$ [kN]	Permissible shear load at $e = 160$ mm $V_{perm}^{3)}$ [kN]	Permissible shear load at $e = 180$ mm $V_{perm}^{3)}$ [kN]	Permissible shear load at $e = 200$ mm $V_{perm}^{3)}$ [kN]	Permissible shear load at $e = 250$ mm $V_{perm}^{3)}$ [kN]	Permissible shear load at $e = 300$ mm $V_{perm}^{3)}$ [kN]	Minimum member thickness h_{min} [mm]	Minimum spacing $s_{min} \parallel / s_{min} \perp^{9)}$ [mm]	Minimum edge distance c_{min} [mm]
Concrete, cracked and non-cracked, strength class $\geq C20/25$														
TherMax 12 ⁹⁾	70	3,40 ⁶⁾	1,22	0,75	0,63	0,54	0,4	0,29	0,22	0,10	0,05	100	55	55
TherMax 16 ⁹⁾	80	3,40 ⁶⁾	1,59	0,99	0,82	0,70	0,62	0,55	0,46	0,22	0,10	116	65	65
Solid brick, Mz, EN 771-1; $f_b \geq 12$ N/mm²; $\rho \geq 1,8$ kg/dm³; LxWxH $\geq 240 \times 115 \times 71$ mm, NF														
TherMax 12 ⁹⁾	200	2,71	0,85	0,75	0,63	0,54	0,36	0,29	0,22	0,10	0,05	240	80/80	60
TherMax 16 ⁹⁾	200	2,71	1,29	0,99	0,82	0,70	0,62	0,55	0,46	0,22	0,10	240	80/80	60
Solid sand-lime brick, KS, EN 771-1; $f_b \geq 20$ N/mm²; $\rho \geq 2,0$ kg/dm³; LxWxH $\geq 250 \times 240 \times 240$ mm, 8DF														
TherMax 12 ⁹⁾	50	2,86	1,22	0,75	0,63	0,54	0,40	0,29	0,22	0,10	0,05	240	80/80	60
TherMax 16 ⁹⁾	50	2,14	1,59	0,99	0,82	0,7	0,62	0,55	0,46	0,22	0,10	240	80/80	60
Vertically perforated brick type B, HLZ, EN 771-1; $f_b \geq 12$ N/mm²; $\rho \geq 1,0$ kg/dm³; LxWxH = 370x240x237 mm resp. 500x175x237 mm														
TherMax 12 ⁹⁾	110	1,14	0,57	0,57	0,57	0,54	0,40	0,29	0,22	0,10	0,05	175	100/100	100
TherMax 16 ⁹⁾	110	1,14	0,57	0,57	0,57	0,57	0,57	0,55	0,46	0,22	0,10	175	100/100	100
Perforated sand-lime brick, KSL, EN 771-2; $f_b \geq 12$ N/mm²; $\rho \geq 1,4$ kg/dm³; LxWxH = 240x175x113 mm, 3DF														
TherMax 12 ⁹⁾	85	1,00	1,22	0,75	0,63	0,54	0,40	0,29	0,22	0,10	0,05	175	100/115	80
TherMax 16 ⁹⁾	85	1,00	1,14	0,99	0,82	0,7	0,62	0,55	0,46	0,22	0,10	175	100/115	80
Hollow block made of light weight concrete, Hbl, EN 771-3; $f_b \geq 2$ N/mm²; $\rho \geq 1,0$ kg/dm³; LxWxH = 362x240x240 mm														
TherMax 12 ⁹⁾	110	0,43	0,26	0,26	0,26	0,26	0,26	0,26	0,22	0,10	0,05	240	100/240	60
TherMax 16 ⁹⁾	180	0,71	0,26	0,26	0,26	0,26	0,26	0,26	0,26	0,22	0,10	240	100/240	60
Aerated concrete (cylindrical drill hole), EN 771-4; $f_b \geq 2$ N/mm²; $\rho \geq 0,35$ kg/dm³; LxWxH $\geq 599 \times 240 \times 249$ mm														
TherMax 12 ⁹⁾	200	1,43	0,43	0,43	0,43	0,43	0,40	0,29	0,22	0,10	0,05	240	80/80	100
TherMax 16 ⁹⁾	200	1,43	0,43	0,43	0,43	0,43	0,43	0,43	0,43	0,22	0,10	240	80/80	100

For the design the complete approval Z-21.8-1837 as well as the European Technical Assessments ETA-20/0603, ETA-20/0729 or ETA-12/0258 have to be considered.

- ¹⁾ The required partial safety factors for material resistance as well as a partial safety factor for load actions of $\gamma_L = 1,4$ are considered.
- ²⁾ Set-up of one or more TherMax in a row in direction of shear, for which the clamping of the attachment prevents a torsion on attachment side due to a sufficient stiffness of the attachment or connecting construction. For a clamping on base substrate side only, see approval.
- ³⁾ For combinations of tensile and shear loads as well as reduced edge distances or spacings (anchor groups) see approval. The values for tensile loads in masonry are valid only, if the joints of the masonry is completely filled with masonry mortar. If the joints are not filled with masonry mortar are not filled with masonry mortar and the edge distance towards the joints is less than c_{min} , the loads have to be reduced by the factor $a_2 = 0,75$. The values for shear loads are valid only, if the joints are filled with masonry mortar. For not completely filled joints they have to be handled like a free edge and a minimum edge distance c_{min} of the anchors to the joints has to be observed. For compression loads and perforated bricks or hollow blocks see approval. Calculative assumed thickness of the attachment $t_{ix} = 6$ mm.
- ⁴⁾ In vertically perforated bricks HLZ, perforated sand-lime bricks KSL as well as hollow blocks made of light weight concrete Hbl the TherMax 12 (standard version) can bridge non-load bearing layers up to 110 mm and the TherMax 16 can bridge them up to 170 mm. Larger usable lengths up to 300 mm are possible, if other perforated sleeves and where required longer anchor rods are used and again the anchorage depth gets reduced - see approval.
- ⁵⁾ The stated permissible loads are valid for anchorages in dry base substrates - use category d/d - and for temperatures up to +50 °C (resp. short-term up to +80 °C) in the area of the injection mortar and during drill hole cleaning in accordance with the approval. The load values apply to anchor rods on base substrate side made of zinc-plated steel grade 8.8 - for other steel grades or stainless steel see approval.
- ⁶⁾ Complies with the permissible tensile load of the TherMax cone.
- ⁷⁾ Intermediate values of the shear load may be linearly interpolated in dependence of "e", if nothing else is mentioned in the approval.
- ⁸⁾ In solid bricks Mz and solid sand-lime bricks KS the TherMax 12 (standard version) can bridge non-load bearing layers up to 190 mm (140 mm in aerated concrete) and the TherMax 16 can bridge them up to 300 mm (270 mm in aerated concrete) - but in solid brick Mz and aerated concrete the above load values have to be reduced. In concrete the TherMax 12 (standard version) can bridge non-loadbearing layers up to 170 mm and the TherMax 16 can bridge them up to 290 mm. Larger usable lengths up to 300 mm are possible, if longer anchor rods are used and again in solid bricks Mz if the anchorage depth (compared to above values) gets reduced where required - see approval.
- ⁹⁾ Minimum spacings for at the same time reduced permissible loads, where required.

Loads

Stand-off installation TherMax 12 and 16 with load-bearing anchor rod made of stainless steel R-70 and a displacement of 3 mm

The below load table is valid for short-term loading (e.g. wind load). Measures for sealing see approval, section 3.2.4.

Highest permissible loads¹⁾⁵⁾⁹⁾ of a TherMax within an anchor group²⁾ in concrete with the injection mortars FIS V Plus or FIS SB and in masonry with the injection mortar FIS V Plus.

Type	Minimum effective anchor-rod depth $h_{ef}^{4)8)}$ [mm]	Permissible tensile load $N_{perm}^{3)}$ [kN]	Permissible shear load at $e = 62$ mm $V_{perm}^{3)}$ [kN]	Permissible shear load at $e = 100$ mm $V_{perm}^{3)}$ [kN]	Permissible shear load at $e = 120$ mm $V_{perm}^{3)}$ [kN]	Permissible shear load at $e = 140$ mm $V_{perm}^{3)}$ [kN]	Permissible shear load at $e = 160$ mm $V_{perm}^{3)}$ [kN]	Permissible shear load at $e = 180$ mm $V_{perm}^{3)}$ [kN]	Permissible shear load at $e = 200$ mm $V_{perm}^{3)}$ [kN]	Permissible shear load at $e = 250$ mm $V_{perm}^{3)}$ [kN]	Permissible shear load at $e = 300$ mm $V_{perm}^{3)}$ [kN]	Minimum member thickness h_{min} [mm]	Minimum spacing $s_{min \parallel} / s_{min \perp}^{9)}$ [mm]	Minimum edge distance c_{min} [mm]
Concrete, cracked and non-cracked, strength class $\geq C20/25$														
TherMax 12 ⁹⁾	70	3,40 ⁶⁾	1,22	0,75	0,63	0,54	0,4	0,29	0,22	0,10	0,05	100	55	55
TherMax 16 ⁹⁾	80	3,40 ⁶⁾	1,59	0,99	0,82	0,70	0,62	0,55	0,46	0,22	0,10	116	65	65
Solid brick, Mz, EN 771-1; $f_b \geq 12$ N/mm²; $\rho \geq 1,8$ kg/dm³; LxWxH $\geq 240 \times 115 \times 71$ mm, NF														
TherMax 12 ⁹⁾	200	2,71	0,85	0,75	0,63	0,54	0,36	0,29	0,22	0,10	0,05	240	80/80	60
TherMax 16 ⁹⁾	200	2,71	1,29	0,99	0,82	0,70	0,62	0,55	0,46	0,22	0,10	240	80/80	60
Solid sand-lime brick, KS, EN 771; $f_b \geq 20$ N/mm²; $\rho \geq 2,0$ kg/dm³; LxWxH = 250x240x240 mm, 8DF														
TherMax 12 ⁹⁾	50	2,86	1,22	0,75	0,63	0,54	0,40	0,29	0,22	0,10	0,05	240	80/80	60
TherMax 16 ⁹⁾	50	2,14	1,59	0,99	0,82	0,7	0,62	0,55	0,46	0,22	0,10	240	80/80	60
Vertically perforated brick type B, HLz, EN 771-1; $f_b \geq 12$ N/mm²; $\rho \geq 1,0$ kg/dm³; LxWxH = 370x240x237 mm resp. 500x175x237 mm														
TherMax 12 ⁹⁾	110	1,14	0,57	0,57	0,57	0,54	0,40	0,29	0,22	0,10	0,05	175	100/100	100
TherMax 16 ⁹⁾	110	1,14	0,57	0,57	0,57	0,57	0,57	0,55	0,46	0,22	0,10	175	100/100	100
Perforated sand-lime brick, KSL, EN 771-2; $f_b \geq 12$ N/mm²; $\rho \geq 1,4$ kg/dm³; LxWxH = 240x175x113 mm, 3DF														
TherMax 12 ⁹⁾	85	1,00	1,22	0,75	0,63	0,54	0,40	0,29	0,22	0,10	0,05	175	100/115	80
TherMax 16 ⁹⁾	85	1,00	1,14	0,99	0,82	0,7	0,62	0,55	0,46	0,22	0,10	175	100/115	80
Hollow block made of light weight concrete, Hbl, EN 771-3; $f_b \geq 2$ N/mm²; $\rho \geq 1,0$ kg/dm³; LxWxH = 362x240x240 mm														
TherMax 12 ⁹⁾	110	0,43	0,26	0,26	0,26	0,26	0,26	0,26	0,22	0,10	0,05	240	100/240	60
TherMax 16 ⁹⁾	180	0,71	0,26	0,26	0,26	0,26	0,26	0,26	0,26	0,22	0,10	240	100/240	60
Aerated concrete (cylindrical drill hole), EN 771-4; $f_b \geq 2$ N/mm²; $\rho \geq 0,35$ kg/dm³; LxWxH $\geq 599 \times 240 \times 249$ mm														
TherMax 12 ⁹⁾	200	1,43	0,43	0,43	0,43	0,43	0,40	0,29	0,22	0,10	0,05	240	80/80	100
TherMax 16 ⁹⁾	200	1,43	0,43	0,43	0,43	0,43	0,43	0,43	0,43	0,22	0,10	240	80/80	100

For the design the complete approval Z-21.8-1837 as well as the European Technical Assessments ETA-20/0603, ETA-20/0729 or ETA-12/0258 have to be considered.

- ¹⁾ The required partial safety factors for material resistance as well as a partial safety factor for load actions of $\gamma_L = 1,4$ are considered.
- ²⁾ Set-up of one or more TherMax in a row in direction of shear, for which the clamping of the attachment prevents a torsion on attachment side due to a sufficient stiffness of the attachment or connecting construction. For a clamping on base substrate side only, see approval.
- ³⁾ For combinations of tensile and shear loads as well as reduced edge distances or spacings (anchor groups) see approval. The values for tensile loads in masonry are valid only, if the joints of the masonry is completely filled with masonry mortar. If the joints are not filled with masonry mortar are not filled with masonry mortar and the edge distance towards the joints is less than c_{min} , the loads have to be reduced by the factor $a_s = 0,75$. The values for shear loads are valid only, if the joints are filled with masonry mortar. For not completely filled joints they have to be handled like a free edge and a minimum edge distance c_{min} of the anchors to the joints has to be observed. For compression loads and perforated bricks or hollow blocks see approval. Calculative assumed thickness of the attachment $t_{fix} = 6$ mm.
- ⁴⁾ In vertically perforated bricks HLz, perforated sand-lime bricks KSL as well as hollow blocks made of light weight concrete Hbl the TherMax 12 (standard version) can bridge non-load bearing layers up to 110 mm and the TherMax 16 can bridge them up to 170 mm. Larger usable lengths up to 300 mm are possible, if other perforated sleeves and where required longer anchor rods are used and again the anchorage depth gets reduced - see approval.
- ⁵⁾ The stated permissible loads are valid for anchorages in dry base substrates - use category d/d - and for temperatures up to +50 °C (resp. short-term up to +80 °C) in the area of the injection mortar and during drill hole cleaning in accordance with the approval. The load values apply to anchor rods on base substrate side made of stainless steel of the grade A4-70.
- ⁶⁾ Complies with the permissible tensile load of the TherMax cone.
- ⁷⁾ Intermediate values of the shear load may be linearly interpolated in dependence of "e", if nothing else is mentioned in the approval.
- ⁸⁾ In solid bricks Mz and solid sand-lime bricks KS the TherMax 12 (standard version) can bridge non-load bearing layers up to 190 mm (140 mm in aerated concrete) and the TherMax 16 can bridge them up to 300 mm (270 mm in aerated concrete) - but in solid brick Mz and aerated concrete the above load values have to be reduced. In concrete the TherMax 12 (standard version) can bridge non-loadbearing layers up to 170 mm and the TherMax 16 can bridge them up to 290 mm. Larger usable lengths up to 300 mm are possible, if longer anchor rods are used and again in solid bricks Mz if the anchorage depth (compared to above values) gets reduced where required - see approval.
- ⁹⁾ Minimum spacings for at the same time reduced permissible loads, where required.

Remedial wall tie mechanical VBS-M

The quick façade repair for two-leaf cavity walls



Facing masonry



Repairing outer leaves

5

Applications

- VBS-M is especially suitable for applications where external thermal insulation composite systems (ETICS) have been previously installed.
- Retrorespective repair of facing masonry.

Advantages

- The approved fixing in stone and in joints from at least 50 mm facing masonry provides a high degree of flexibility and security.
- Use in joints and with a low anchorage depth of just 50 mm allows for a quick and economical installation.
- The small anchor rim and screw head

allow for a surface-flush or deep-set installation.

- The drill hole can be retrospectively sealed so that it is no longer visible in the façade.
- A drip coil prevents condensate running into the load-bearing layer, thus preventing frost and corrosive damage.

Certificates



Building materials

- Facing masonry with and without an air layer

Versions

- Zinc-plated steel
- Stainless steel

Functioning

- The remedial wall tie VBS-M is set in the load-bearing layer and into facing masonry using push-through installation.
- In accordance with the approval, no drill hole cleaning is required.
- The two expansion zones in the load-bearing layer and in the facing masonry ensure a secure fixation.
- The plug doesn't fix into the facing masonry until the head grips into the load-bearing layer. This ensures the very best installation safety.

Installation VBS-M

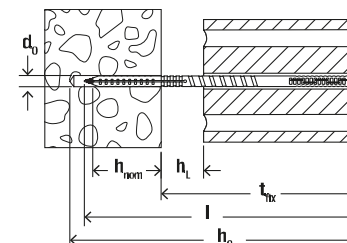

5

Technical data

Remedial wall tie mechanical VBS-M

VBS-M

Item	Zinc-plated steel	Stainless steel	Approval	Max. shell distance at 115 mm facing masonry, flush installation	Max. shell distance at 115 mm facing masonry, 20 mm sunk installation	Facing masonry + cavity	Drill diameter	Drill hole depth	Effect. anchoring depth	Anchor length	Sales unit
	Item No.	Item No.		[mm]	[mm]	t_{fix} [mm]	d_0 [mm]	h_0 [mm]	h_{nom} [mm]	l [mm]	[pcs]
VBS-M 8 x 120	514243	514236	●	20*	—	70	8	140	>50	120	100
VBS-M 8 x 185	514244	514237	●	20	40	135	8	205	>50	185	100
VBS-M 8 x 205	514245	514238	●	40	60	155	8	225	>50	205	100
VBS-M 8 x 225	514246	514239	●	60	80	175	8	245	>50	225	100
VBS-M 8 x 245	514247	514240	●	80	100	195	8	265	>50	245	100
VBS-M 8 x 265	514248	514241	●	100	120	215	8	285	>50	265	100
VBS-M 8 x 285	514249	514242	●	120	140	235	8	305	>50	285	100

* Max. 20 mm mortar layer in the case of 50 mm thick economy facing.

Accessories

Drill bits

SDS Plus IV 8/100/400

Pointer M 8/100/400

 SDS Plus II Pointer
8/400/460

Item	Item No.	Description	Sales unit [pcs]
SDS PLUS IV 8/100/400	517689	fischer Quattric drill bit with SDS-plus shank and short flute for drilling in concrete	1
Pointer M 8/100/400	517690	fischer masonry drill bit with SDS-plus shank and short flute, ground sharp, for rotary drilling in perforated brick and in the bed joint	1
SDS Plus-V II 8/400/460	531785	fischer hammer drill bit for drilling in concrete and in the facing brick	1

Accessories

ProfiBit



FPB TX

	Item No.	Description	Sales unit [pcs]
Item			
FPB TX 25 ProfiBit W5	517693	fischer ProfiBit long, which can be extended to 50 mm bit, allows for deep setting in stone and in the bed joint	1



6

General fixings

DuoPower	362		Brass fixing MS	396	
DuoSeal	366		Aircrete anchor GB	398	
Universal plug UX	369		Aircrete anchor GB GREEN	401	
Universal plug UX GREEN	374		Turbo aircrete anchor FTP K	404	
Expansion plug SX	377		Turbo aircrete anchor FTP M	407	
Expansion plug SX GREEN	381		Brass fixing PA 4	410	
Expansion plug S	384		Balcony cladding fixing P 9 K	412	
Threaded rod plug RodForce FGD	387		Stair-tread fixing TB / TBB	414	
Metal expansion anchor FMD	390		Repair pad FixIt	416	
Expansion plug M-S	392		Doorstop TS	418	
Anchor M	394				

DuoPower

The duo of power and intelligence



Wall applications



Wall consoles

6

Applications

- TV consoles
- Lighting
- Shelves
- Mirror cabinets
- Letter boxes
- Pictures
- Fixing blinds
- Curtain rails
- Wash basin fixings
- Plumbing and heating fixings
- Bath and toilet installations
- Wall cabinets
- Range hood

Advantages

- Two component materials for top load values and intelligent functioning (expansion, folding, knotting), depending on building material - solid, perforated or panel material.
- Great feedback (feel-good-factor) of the plug. You can feel exactly when the plug is installed perfectly.
- The narrow plug rim prevents slipping into the drill hole.
- The serrated anti-rotation feature interlock in the building material and prevents rotation in the drill hole during installation.
- The greater anchorage depth of the DuoPower 6 x 50, 8 x 65 and 10 x 80 means that the plug is especially suited to fixings in hollow building materials, aerated concrete and to bridge plaster.

Certificates



Building materials

- Concrete
- Solid brick
- Solid sand-lime brick
- Aerated concrete
- Vertically perforated brick
- Perforated sand-lime brick
- Plasterboard
- Gypsum plasterboard and gypsum fibreboards
- Hollow blocks made from lightweight concrete
- Cavity floor slabs made from bricks and concrete or similar
- Natural stone
- Chipboard
- Solid panel made from gypsum
- Solid brick made from lightweight concrete

Functioning

- The grey component made from high quality nylon automatically activates for the optimum product function (expansion, folding, knotting) for the best hold.
- The red expansion wings support the safe expansion and offer additional safety for the grey component.
- The smooth-running opening allows the simple positioning of the screw and the secure guiding and fixing in the screw channel.
- The required screw length is given by the plug length + fixture thickness + the screw diameter.
- Suitable for wood and chipboard screws, as well as stud screws.
- In the case of fixing boards, the threadless part of the screw must not be longer than the fixture.

Installation in solid building materials

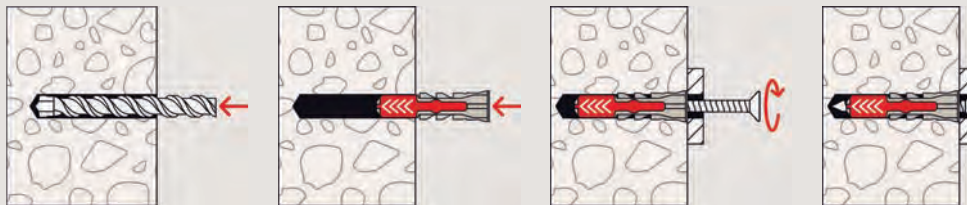

Installation in hollow building materials

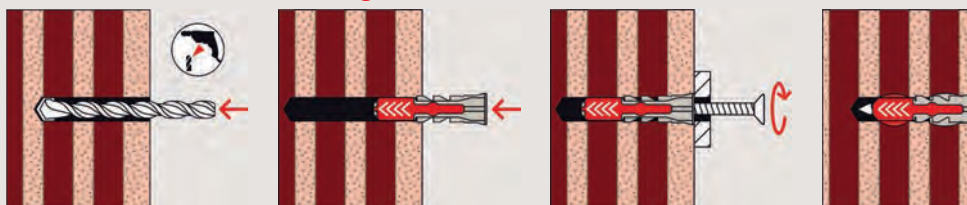

Installation in panel building materials

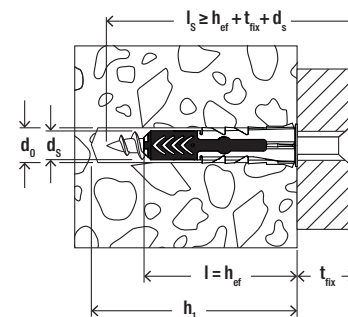
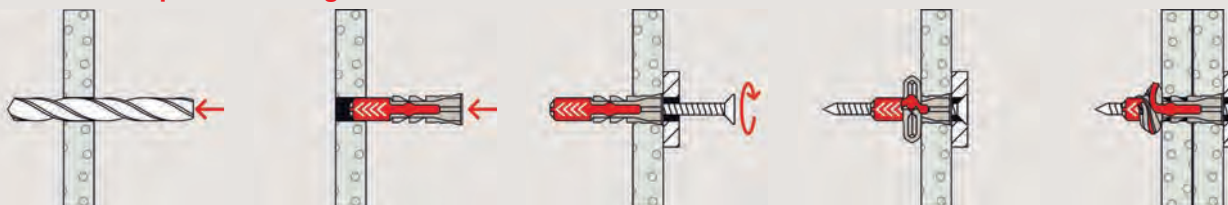

Technical data

2-component plug DuoPower



DuoPower



DuoPower with greater anchorage depth

Item	without screw	with screw	Drill hole diameter	Min. drill hole depth	Min. panel thickness	Min. bolt penetration	Anchor length	Wood and chipboard screws	Drive	Max. fixture thickness	Sales unit
	Item No.	Item No.	d_0 [mm]	h_1 [mm]	d_p [mm]	$l_{E,min}$ [mm]	l [mm]	$d_s / d_s \times l_s$ [mm]		t_{fix} [mm]	[pcs]
DuoPower 5 x 25	555005	—	5	35	12,5	29	25	3 - 4	—	—	100
DuoPower 6 x 30	555006	—	6	40	12,5	35	30	4 - 5	—	—	100
DuoPower 6 x 50	538240	—	6	60	12,5	55	50	4 - 5	—	—	100
DuoPower 8 x 40	555008	—	8	50	12,5	46	40	4,5 - 6	—	—	100
DuoPower 8 x 65	538241	—	8	75	2 x 12,5	71	65	4,5 - 6	—	—	50
DuoPower 10 x 50	555010	—	10	60	12,5	58	50	6 - 8	—	—	50
DuoPower 10 x 80	538242	—	10	100	—	88	80	6 - 8	—	—	25

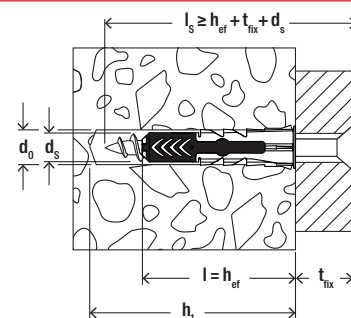

Technical data

2-component plug DuoPower



DuoPower



DuoPower with greater anchorage depth

6

Item	without screw	with screw	Drill hole diameter	Min. drill hole depth	Min. panel thickness	Min. bolt penetration	Anchor length	Wood and chipboard screws	Drive	Max. fixture thickness	Sales unit
	Item No.	Item No.	d_0 [mm]	h_1 [mm]	d_p [mm]	$l_{E,min}$ [mm]	l [mm]	$d_s / d_s \times l_s$ [mm]			
DuoPower 12 x 60	538243	—	12	90	—	70	60	8 - 10	—	—	25
DuoPower 14 x 70	538244	—	14	90	—	82	70	10 - 12	—	—	20
DuoPower 5 x 25 S	—	555105	5	40	12,5	29	25	3,5 x 35	PZ2	6	50
DuoPower 6 x 30 S	—	555106	6	45	12,5	35	30	4,5 x 40	PZ2	5	50
DuoPower 6 x 30 S PH TX	—	545838	6	45	12,5	34	30	4,5 x 40	—	6	100
DuoPower 6 x 50 S	—	538245	6	65	12,5	55	50	4,5 x 60	PZ2	5	50
DuoPower 8 x 40 S	—	555108	8	60	12,5	45	40	5 x 55	PZ2	15	50
DuoPower 8 x 65 S	—	538246	8	85	2 x 12,5	70	65	5 x 80	PZ2	10	25
DuoPower 10 x 50 S	—	555110	10	74	12,5	57	50	7 x 69	SW 13 / TX 40	13	25
DuoPower 10 x 80 S	—	538247	10	112	—	87	80	7 x 107	SW 13	20	10
DuoPower 12 x 60 S	—	538248	12	85	—	68	60	8 x 80	SW 13	12	10
DuoPower 14 x 70 S	—	538249	14	100	—	80	70	10 x 95	SW 17	15	8

Loads

DuoPower

Highest recommended loads¹⁾ for a single anchor.

The given loads are valid for wood screws with the specified diameter.

Type		5 x 25	6 x 30	6 x 50	8 x 40	8 x 65	10 x 50	10 x 80	12 x 60	14 x 70	
Wood screw diameter	[mm]	4	5	5	6	6	8	8	10	12	
Min. edge distance concrete c_{min}	[mm]	30	35	35	50	50	65	65	80	100	
Recommended loads in the respective base material F_{rec} ²⁾											
Concrete	≥ C20/25	[kN]	0.40	0.95	1.65	1.10	2.30	2.15	4.20	3.30	5.30
Solid brick	≥ Mz 12	[kN]	0.30	0.50	0.55	0.62	0.69	1.20	1.45	1.30	1.35
Solid sand-lime brick	≥ KS 12	[kN]	0.50	1.00	1.60	1.25	2.25	2.20	3.85	2.80	4.50
Aerated concrete	≥ AAC 2 (G2)	[kN]	0.05	0.10	0.15	0.10	0.16	0.20	0.30	0.24	0.35
Aerated concrete	≥ AAC 4 (G4)	[kN]	0.25	0.38	0.55	0.42	0.60	0.60	1.10	1.00	1.45
Vertically perforated brick	≥ Hlz 12 ($\rho \geq 0.9 \text{ kg/dm}^3$)	[kN]	0.13	0.15	0.17	0.25	0.40	0.25	0.40	0.35	0.40
Perforated sand-lime brick	≥ KSL 12 ($\rho \geq 1.6 \text{ kg/dm}^3$)	[kN]	0.40	0.60	0.60	0.70	1.00	0.70	2.00	0.75	1.50
Gypsum block	($\rho \geq 0,9 \text{ kg/dm}^3$)	[kN]	0.10	0.18	0.37	0.25	0.50	0.35	0.65	0.50	0.50
Gypsum fibreboard	12.5 mm	[kN]	0.24	0.33	0.35	0.35	-	0.50	-	-	-
Gypsum plasterboard	12.5 mm	[kN]	0.12	0.15	0.15	0.15	-	0.15	-	-	-
Gypsum plasterboard	2 x 12.5 mm	[kN]	0.13	0.15	0.24	0.20	0.32	0.30	-	-	-
Mattone Forato Typ F8		[kN]	0.30	0.30	-	0.25	-	0.25	-	-	-
Tramezza Doppio UNI 19		[kN]	0.15	0.15	0.23	0.15	0.30	0.20	0.52	0.35	0.35
Sepa Parpaing		[kN]	0.30	0.45	0.25 ³⁾	0.45	0.45 ³⁾	0.45	0.45 ³⁾	0.60 ³⁾	0.60 ³⁾

¹⁾ Required safety factors are considered.

²⁾ Valid for tensile load, shear load and oblique load under any angle.

³⁾ Load determination on plastered wall.

DuoSeal

The sealing plug for wet areas

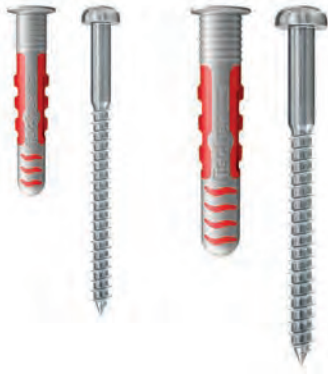

Fixings on tiled surfaces



Accessories in wet areas

6

Applications

Tiled surfaces in wet areas, like:

- Bathrooms, showers and toilets
- Kitchen
- Garage
- Laundry room
- Swimming pool
- Steam bath
- Sports facilities

Suitable for:

- Bathroom accessories
- Fittings
- Shower cubicles
- Mirrors
- Light shelves
- Trays
- Kitchen accessories

Advantages

- The DuoSeal completely seals drill holes in tiles without additional sealing compound and thus prevents structural damage caused by moisture in the building material.
- The DuoSeal is ideally suited for tiled surfaces which are exposed to very frequent splash water and temporarily accumulating water.
- The watertightness is confirmed in accordance with ETAG 022 and DIN 18534 up to the water exposure class W3-I. In any case, please take note of the general

national regulations on the use of plugs in wet areas.

- It's red component ensures a secure hold in all building materials. Thus, the DuoSeal achieves the same load values as conventional nylon plugs.
- The stainless-steel screw included in the set is ideally suited for installation in wet areas and avoids rusting.
- The soft plastic rim closes the drill hole completely and flexibly adapts to the shape of the attachment part.

Certificates



Building materials

- Concrete
- Solid brick
- Solid sand-lime brick
- Aerated concrete
- Vertically perforated brick
- Perforated sand-lime brick
- Gypsum plasterboard
- Gypsum fibreboard
- Plasterboard

Functioning

- The DuoSeal is only suitable for application on tiles and can only be mounted as pre-position installation.
- The DuoSeal can be installed gently on tiles with just a few hammer blows. The rim of the shaft prevents the plug from being set too deep and additionally seals the drill hole.
- The red component made of high-quality nylon automatically activates the optimum function principle depending on the building material for best hold.
- The soft grey component is pressed against the drill hole wall by screwing in the screw and seals the drill hole completely.
- The grooves in the plug shaft compensate for unevenness in the hole, so that the sealing function is guaranteed even if the drill hole is not perfect.

Installation in solid building materials

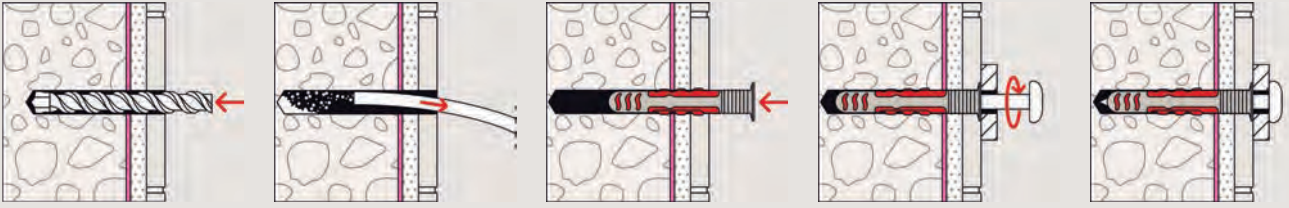

Installation in masonry

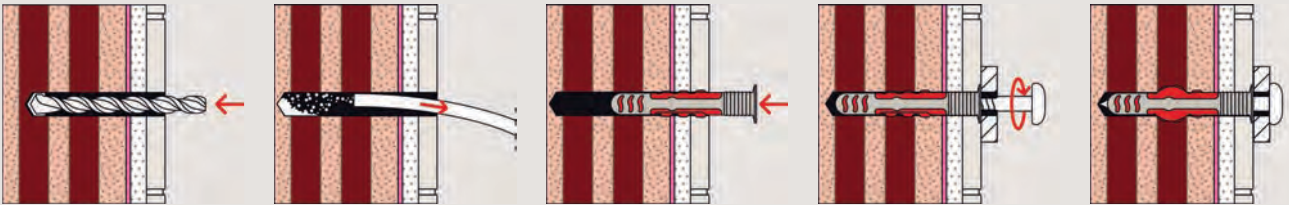

Installation in panel building materials

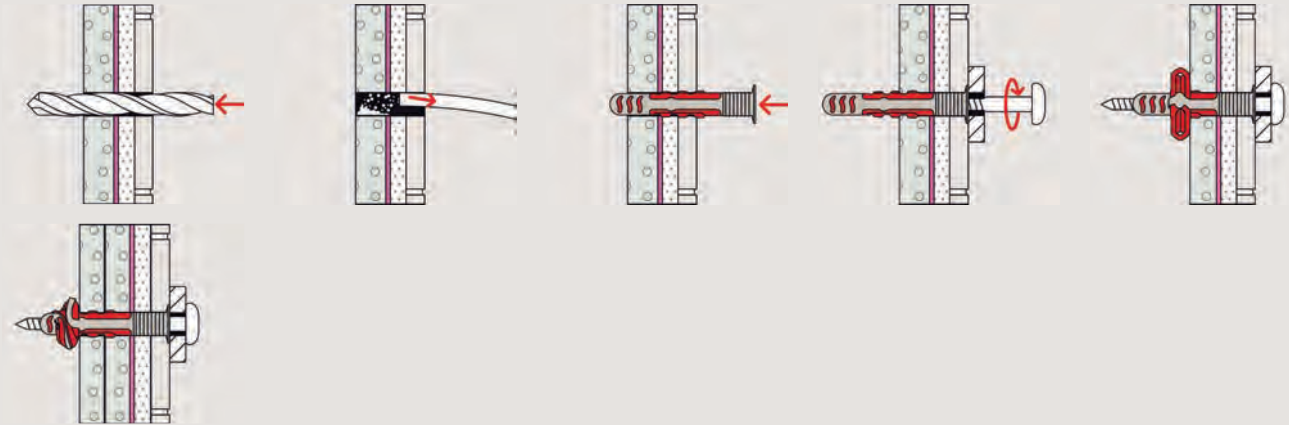

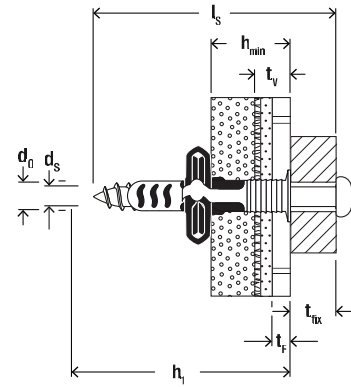

Technical data

DuoSeal

6



DuoSeal 6

DuoSeal 8

Item	Item No.	Drill diameter d_0 [mm]	Drill hole diameter tolerance [mm]	Min. drill hole depth h_1 [mm]	Max. fixture thickness t_{fix} [mm]	Min. building material thickness h_{min} [mm]	Screw $d_s \times l_s$ [mm]	Drive	Sealing depth t_v [mm]	Tile thickness t_F [mm]	Sales unit [pcs]
DuoSeal 6 x 38 S A2	557727	6	6,0 - 6,40	65 - t_{fix}	12	22	4,5 x 60	TX20	5 - 14	5 - 10	50
DuoSeal 8 x 48 S A2	557728	8	8,0 - 8,45	75 - t_{fix}	16	25	6 x 70	TX30	5 - 14	5 - 10	25

Loads

DuoSeal

Recommended loads¹⁾ for a single anchor.

Type		DuoSeal 6	DuoSeal 8
Screw diameter	[mm]	4.5	6.0
Recommended loads in the respective base material F_{rec} ^{2) 3)}			
Concrete	\geq C20/25	[kN] 0.40	0.60
Solid brick	\geq Mz 12	[kN] 0.20	0.30
Solid sand-lime brick	\geq KS 12	[kN] 0.30	0.40
Aerated concrete	\geq ACC 2	[kN] 0.10	0.10
Vertically perforated brick	\geq HLZ 12	[kN] 0.20	0.30
Perforated sand-lime brick	\geq KSL 12	[kN] 0.30	0.40
Gypsum plasterboard impregnated (green)	12.5 mm	[kN] 0.10	0.10 ⁴⁾
Gypsum plasterboard impregnated (green)	2 x 12.5 mm	[kN] 0.15	0.15
Gypsum plasterboard hard and impregnated (e. g. Knauf Diamant board or Rigipis Die Harte)	12.5 mm	[kN] 0.15	0.15
Gypsum plasterboard hard and impregnated (e. g. Knauf Diamant board or Rigipis Die Harte)	2 x 12.5 mm	[kN] 0.20	0.20
Gypsum fibreboard	12.5 mm	[kN] 0.20	0.20
Gypsum block	$\rho \geq 0.85 \text{ kg/dm}^3$	[kN] 0.10	0.10

¹⁾ Required safety factor is considered.

Load values are valid for using the supplied screws and under consideration of the total tile thickness: tile + tile glue + sealing compound.

²⁾ Valid for tensile load, shear load and oblique load under any angle.

³⁾ Values apply to tile thickness 5 - 10 mm and total tile thickness 9.5 - 14.5 mm.

⁴⁾ Value applies to tile thickness 8 - 10 mm and total tile thickness 12.5 - 14.5 mm.

Universal plug UX

The nylon plug for all building materials



Mirror fixings



Pictures

Applications

- Pictures
- Lighting
- Skirting
- Light cabinets
- Towel rails
- Mirror cabinets
- Curtain rails
- Wash basin fixings
- TV consoles
- Plumbing and heating fixings

Advantages

- The universal operating principle (knotting or expanding) allows for use in all solid, hollow and board building materials. Thus the UX is the correct choice for unknown base materials.
- The UX's angled connection ridges allow for optimum screw guidance. Serrated

- anti-rotation locks prevent rotation in the drill hole. This guarantees the greatest possible installation safety.
- Fixing sets with screws, eye screws and hooks provide the right solution for all applications.

Certificates



Building materials

- Concrete
- Gypsum plasterboard and gypsum fibreboards
- Vertically perforated brick
- Hollow blocks made from lightweight concrete
- Cavity floor slabs made from bricks and concrete
- Perforated sand-lime brick
- Solid sand-lime brick
- Natural stone
- Aerated concrete
- Chipboard
- Solid panel made from gypsum
- Solid brick made from lightweight concrete
- Solid brick

Functioning

- The UX with rim is suitable for pre-positioned installation; the UX without rim is suitable for push-through installation.
- Turning in the screw causes the UX to expand in the solid building material and to knot within the cavity.
- The required screw length is given by the plug length + fixture thickness + 1 x screw diameter.
- Suitable for wood and chipboard screws, as well as stud screws.
- In the case of board building materials, the threadless part of the screw must not be longer than the fixture, and the UX with rim is to be used.
- The edge distance must be at least one plug length.

Installation UX

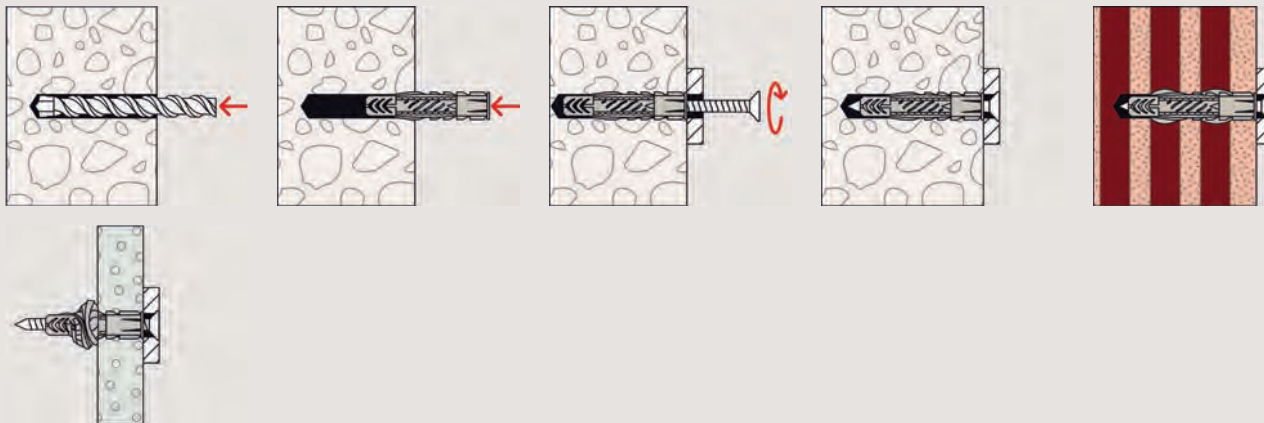

6

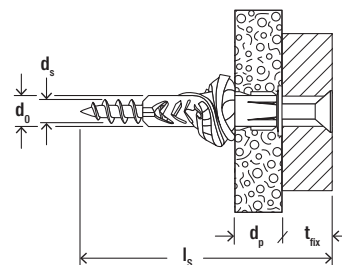
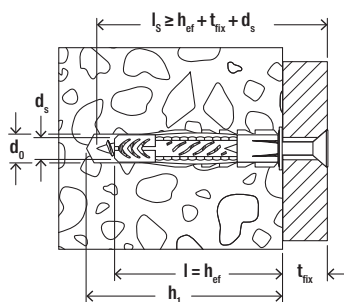

Technical data

Universal plug UX



Item	Without rim	With rim	With rim and screw	Drill hole diameter	Min. drill hole depth	Min. panel thickness	Anchor length	Wood and chipboard screws	Max. fixture thickness	Sales unit
	Item No.	Item No.	Item No.	d_0 [mm]	h_1 [mm]	d_p [mm]	l [mm]	$d_s / d_s \times l_s$ [mm]	t_{fix} [mm]	[pcs]
UX 5 x 30	094721	094722	—	5	40	9,5	30	3 - 4	—	100
UX 6 x 35	062754	062756	—	6	45	9,5	35	4 - 5	—	100
UX 6 x 35	—	—	094758	6	50	9,5	35	4,5 x 45	20	25
UX 6 x 50	072094	072095	—	6	60	9,5	50	4 - 5	—	100
UX 6 x 50	—	—	094759	6	65	9,5	50	4,5 x 60	5	25
UX 8 x 40	—	505483	—	8	50	9,5	40	4,5 - 6	—	100
UX 8 x 50	077869	077870	—	8	60	9,5	50	4,5 - 6	—	100
UX 8 x 50	—	—	094760	8	70	9,5	50	5 x 65	10	25
UX 10 x 60	077871	077872	—	10	75	12,5	60	6 - 8	—	50
UX 10 x 60	094761	¹⁾ —	—	10	90	12,5	60	6 x 85	20	10
UX 12 x 70	062758	—	—	12	85	—	70	8 - 10	—	25
UX 14 x 75	062757	—	—	14	95	—	75	10 - 12	—	20

¹⁾ with screw

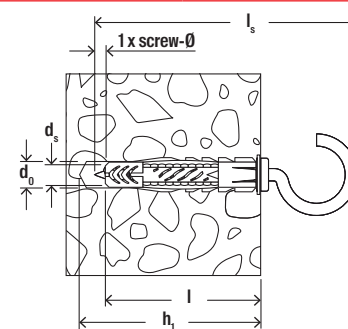

Technical data

Universal plug UX with hook



UX RH - with rim and round hook

UX RH N - with rim and round hook (white coated)

UX WH - with rim and angle hook

UX WH N - with rim and angle hook (white coated)

UX OH N - with rim and eyebolt (white coated)

Item	With rim and round hook	With round hook (white coated)	With rim and angle hook	With angle hook (white coated)	With eye-bolt (white coated)	Drill hole diameter	Min. drill hole depth	Min. panel thickness	Anchor length	Screw dimension	Sales unit
	Item No.	Item No.	Item No.	Item No.	Item No.	d_0 [mm]	h_1 [mm]	d_p [mm]	l [mm]	$d_s \times l_s$ [Ø mm]	[pcs]
UX 6 x 35	094407	—	—	—	—	6	45	9,5	35	4,5 x 67	25
UX 6 x 35	—	—	094408	—	—	6	45	9,5	35	4,5 x 51	25
UX 8 x 50	094409	094412	—	—	094414	8	60	9,5	50	5,5 x 87	25
UX 8 x 50	—	—	094410	094413	—	8	60	9,5	50	5,5 x 70	25

Technical data

Universal plug UX in bucket



UX in bucket

Item	Item No.	Drill hole diameter	Min. drill hole depth	Anchor length	Min. panel thickness	Wood and chipboard screws	Sales unit
		d_0 [mm]	h_1 [mm]	l [mm]	d_p [mm]	$d_s / d_s \times l_s$ [mm]	[pcs]
UX 6 x 35 R in bucket	508027	6	45	40	9,5	4 - 5	2500
UX 8 x 50 R in bucket	508028	8	60	50	9,5	4,5 - 6	1000
UX 10 x 60 R in bucket	508029	10	75	60	12,5	6 - 8	600

Technical data

Assortment boxes



Assortment box UX / SX

Box UX / SX-S

Item	Item No.	Contents	Sales unit [pcs]
Box UX 6/8/10	093182	100 plugs UX 6 x 35, 70 plugs UX 8 x 50, 20 plugs UX 10 x 60	1
Assortment box UX / SX	040991	60 plugs SX 6 x 30, 50 plugs SX 8 x 40, 20 plugs SX 10 x 50, 60 plugs UX 5 x 30 R, 40 plugs UX 6 x 50 R, 50 plugs UX 8 x 50 R, 10 plugs UX 10 x 60 R	1
Box UX / SX-S	093181	50 plugs UX 6 x 35, 50 screws 4,5 x 45, 50 plugs SX 6 x 30, 50 screws 4,5 x 40, 25 plugs UX 8 x 50, 25 screws 5 x 65, 25 plugs SX 8 x 40, 25 screws 5 x 55	1
Meister-Box UX + screws + hooks	513894	German version: 50 Universal plugs UX 6 x 35 R, 25 Universal plugs UX 8 x 50 R, 20 Chipboard screws 4,5 x 45, 15 Chipboard screws 5 x 65, 4 Angle hooks 5,5, x 70, 4 Round hooks 5,5 x 70	1
Meister-Box UX / UX-R	513893	German version: 25 Universal plugs UX 6 x 35, 25 Universal plugs UX 6 x 35 R, 25 Universal plugs UX 8 x 50, 25 Universal plugs UX 8 x 50 R, 10 Universal plugs UX 10 x 60	1
Profi-Box UX / UX-R	518527	International version: 25 Universal plugs UX 6 x 35, 25 Universal plugs UX 6 x 35 R, 25 Universal plugs UX 8 x 50, 25 Universal plugs UX 8 x 50 R, 10 Universal plugs UX 10 x 60	1
Profi-Box UX + screws + hooks	518526	International version: 50 Universal plugs UX 6 x 35 R, 25 Universal plugs UX 8 x 50 R, 20 Chipboard screws 4,5 x 45, 15 Chipboard screws 5 x 65, 4 Angle hooks 5,5, x 70, 4 Round hooks 5,5 x 70	1

6

Loads

Universal plug UX

Highest recommended loads¹⁾ for a single anchor.
The given loads are valid for wood screws with the specified diameter.

Type		UX 5 x 30	UX 6 x 35	UX 6 x 50	UX 8 x 40 UX 8 x 50	UX 10 x 60	UX 12 x 70	UX 14 x 75	
Wood screw diameter	[mm]	4	5	5	6	8	10	12	
Recommended loads in the respective base material F_{rec}²⁾									
Concrete	≥ C20/25	[kN]	0.30	0.40	0.60	0.60	1.00	1.50	1.80
Solid brick	≥ Mz 12	[kN]	0.20	0.20	0.30	0.30	0.50	0.70	0.80
Perforated sand-lime brick	≥ KSL 12	[kN]	0.30	0.40	0.40	0.50	0.60	0.80	0.80
Vertically perforated brick	≥ Hlz 12	[kN]	0.20	0.20	0.20	0.20	0.20	0.30	0.40
Aerated concrete	≥ AAC 4 (G4)	[kN]	0.15	0.20	0.20	0.30	0.40	0.60	0.70
Gypsum plasterboard	12.5 mm	[kN]	0.10	0.10	0.10	0.10	0.10	-	-
Gypsum plasterboard	25 mm	[kN]	0.10	0.15	0.15	0.15	0.15	-	-
Gypsum fibreboard	(Fermacell)	[kN]	0.20	0.20	0.20	0.20	0.25	-	-
Gypsum block	ρ ≥ 0.9 kg/dm ³	[kN]	-	-	-	0.15	0.35	0.45	0.50

¹⁾ Required safety factors are considered.

²⁾ Valid for tensile load, shear load and oblique load under any angle.

Loads

Universal plug UX with hook screws respective eye screws

Highest recommended loads¹⁾ for a single anchor.
The given loads are valid for the included hook screws respective eye screws.

Type		UX 6 x 35 RH	UX 6 x 35 WH	UX 8 x 50 RH	UX 8 x 50 WH	UX 8 x 50 OE	
Recommended loads in the respective base material F_{rec}²⁾							
Concrete	≥ C20/25	[kN]	0.25	0.30	0.40	0.45	0.40
Vertically perforated brick	≥ Hlz 12	[kN]	0.20	0.20	0.20	0.20	0.20
Gypsum plasterboard	12.5 mm	[kN]	0.05	0.05	0.05	0.05	0.05

¹⁾ Required safety factors are considered.

Universal plug UX Green

The nylon plug for all building materials



Curtain rails



Shelves

6

Applications

- Pictures
- Lighting
- Skirting
- Light cabinets
- Towel rails
- Mirror cabinets
- Curtain rails
- Wash basin fixings
- TV consoles
- Plumbing and heating fixings

Advantages

- Produced with at least 50% renewable raw materials and therefore particularly environmentally friendly.
- Just as effective, secure and durable as regular UX plugs.
- The universal operating principle (knotting or expanding) allows for use in all solid,

hollow and board building materials. Thus the UX Green is the correct choice for unknown base materials.

- Plug collar for anti-slip safety and saw tooth sides as turning lock ensure the highest installation safety.

Certificates



Building materials

- Concrete
- Gypsum plasterboard and gypsum fibreboards
- Vertically perforated brick
- Hollow blocks made from lightweight concrete
- Cavity floor slabs made from bricks and concrete
- Perforated sand-lime brick
- Solid sand-lime brick
- Natural stone
- Aerated concrete
- Chipboard
- Solid panel made from gypsum
- Solid brick made from lightweight concrete
- Solid brick

Functioning

- The Universal plug UX with rim is suitable for pre-positioned installation; the UX without rim is suitable for push-through installation.
- When screwing in the screw, the UX GREEN expands in solid building materials and knots itself into cavities.
- Suitable for wood and chipboard screws, as well as stud screws.
- The required screw length is given by: the plug length + fixture thickness + 1 x screw diameter.
- In the case of board building materials, the threadless part of the screw must not be longer than the fixture.
- The edge distance must be at least one plug length.

Installation UX Green

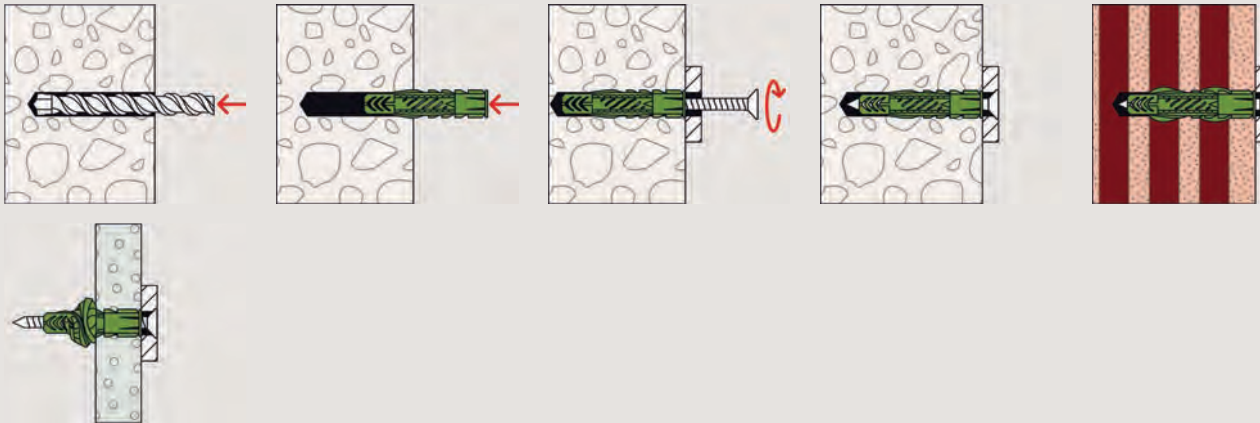

6

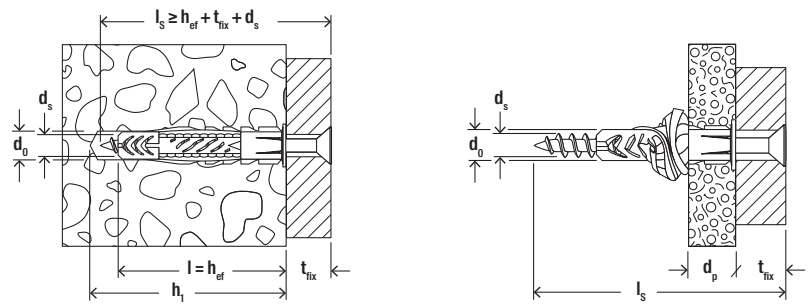

Technical data

Universal plug UX Green



with rim

without rim

Item	With rim	Without rim	Drill hole diameter d_0 [mm]	Min. drill hole depth h_1 [mm]	Min. panel thickness d_p [mm]	Anchor length l [mm]	Wood and chipboard screws $d_s / d_s \times l_s$ [mm]	Sales unit [pcs]
	Item No. UX R	Item No. UX						
UX Green 6 x 35	518885	—	6	45	9,5	35	4 - 5	40
UX Green 6 x 50	524855	—	6	60	9,5	50	4 - 5	40
UX Green 8 x 50	518886	—	8	60	9,5	50	4,5 - 6	40
UX Green 10 x 60	518887	—	10	75	12,5	60	6 - 8	20
UX Green 12 x 70	—	524858	12	85	—	70	8 - 10	18

Loads

Universal plug UX Green

Highest recommended loads¹⁾ for a single anchor.

The given loads are valid for wood screws with the specified diameter.

Type		UX Green 6 x 35	UX Green 6 x 50	UX Green 8 x 50	UX Green 10 x 60	UX Green 12 x 70
Screw diameter	[mm]	5	5	6	8	10
Recommended loads in the respective base material $F_{rec}^{2)}$						
Concrete	≥ C20/25	[kN] 0.40	0.60	0.60	1.00	1.50
Solid brick	≥ Mz 12	[kN] 0.20	0.30	0.30	0.50	0.70
Perforated sand-lime brick	≥ KSL 12	[kN] 0.40	0.40	0.50	0.60	0.80
Vertically perforated brick	≥ Hlz 12	[kN] 0.20	0.20	0.20	0.20	0.30
Aerated concrete	≥ AAC 4 (G4)	[kN] 0.20	0.20	0.30	0.40	0.60
Gypsum plasterboard	12.5 mm	[kN] 0.10	0.10	0.10	0.10	-
Gypsum plasterboard	25 mm	[kN] 0.15	0.15	0.15	0.15	-
Gypsum fibreboard	(Fermacell)	[kN] 0.20	0.20	0.20	0.25	-
Gypsum block	$\rho \geq 0.9 \text{ kg/dm}^3$	[kN] -	-	0.15	0.35	0.45

¹⁾ Required safety factors are considered.

²⁾ Valid for tensile load, shear load and oblique load under any angle.

Expansion plug SX

The powerful nylon plug with 4-way expansion



Wall consoles



Curtain rails

6

Applications

- Lighting
- Wardrobes
- Motion detectors
- Skirting
- Light shelves
- Mirror cabinets
- Letter boxes
- TV consoles
- Trellis
- Folding shutters
- Bath and toilet installations

Certificates



Advantages

- The 4-way expansion provides the optimum force distribution in the material, and offers high load-bearing capacities in solid and hollow building materials.
- The expansion-free plug neck prevents the creation of expansion forces on the material surface whilst screwing in the screw. This helps to prevent damage to tiles and plaster.

- The pronounced rim prevents the plug from slipping into the drill hole, thus allowing for a simple installation.
- The greater anchorage depth of the SX 6x50, 8x65 and 10x80 means that the plug is especially suited to fixings in hollow building materials, aerated concrete and to bridge plaster.

Building materials

- Concrete
- Vertically perforated brick
- Hollow blocks made from lightweight concrete
- Cavity floor slabs made from bricks and concrete
- Perforated sand-lime brick
- Solid sand-lime brick
- Natural stone with dense structure
- Aerated concrete
- Solid panel made from gypsum
- Solid brick made from lightweight concrete
- Solid brick

Functioning

- The SX is suitable for pre-positioned and push-through installation.
- When turning in the screw, the SX expands in four directions, thus providing a secure anchoring in the building material.
- The required screw length is given by: Plug length + fixture thickness + 1 x screw diameter.
- Suitable for wood, chipboard and spacing screws.

Installation SX

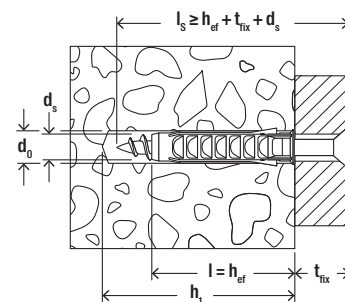
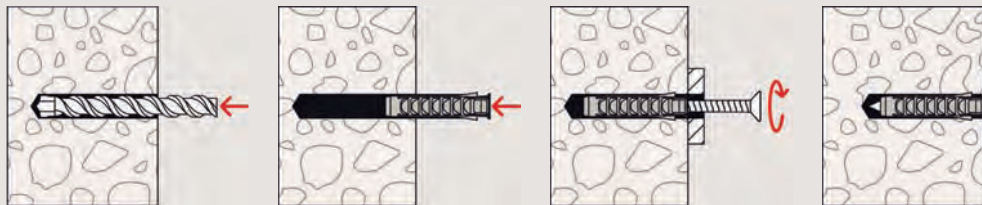

6

Technical data

Expansion plug SX



SX with rim

SX with greater anchorage depth, without rim

SX S with rim and screw

Item	With rim	With greater anchorage depth, without rim	With rim and screw	Drill hole diameter	Min. drill hole depth	Anchor length	Wood and chipboard screws	Max. fixture thickness	Sales unit
	Item No. SX	Item No. SX	Item No. SX-S	d_0 [mm]	h_1 [mm]	l [mm]	$d_s / d_s \times l_s$ [mm]	t_{fix} [mm]	[pcs]
SX 4 x 20	070004	—	—	4	25	20	2 - 3	—	200
SX 5 x 25	070005	—	—	5	35	25	3 - 4	—	100
SX 6 x 30	070006	—	—	6	40	30	4 - 5	—	100
SX 6 x 30	—	—	070021	6	45	30	4,5 x 40	5	50
SX 6 x 30 S PH TX	—	—	545839	6	40	30	4,5 x 40	—	100
SX 6 x 50	078185	024827	—	6	60	50	4 - 5	—	100
SX 8 x 40	070008	—	—	8	50	40	4,5 - 6	—	100
SX 8 x 40	—	—	070022	8	60	40	5 x 60	15	50
SX 8 x 65	—	024828	—	8	75	65	4,5 - 6	—	50
SX 10 x 50	070010	—	—	10	60	50	6 - 8	—	50
SX 10 x 80	—	024829	—	10	95	80	6 - 8	—	25
SX 12 x 60	070012	—	—	12	80	60	8 - 10	—	25
SX 14 x 70	070014	—	—	14	90	70	10 - 12	—	20
SX 16 x 80	070016	—	—	16	100	80	12 (1/2")	—	10

Technical data

Expansion plug SX in bucket



SX in bucket

Item	Item No.	Drill hole diameter	Min. drill hole depth	Anchor length	Wood and chipboard screws	Sales unit
		d_0 [mm]	h_1 [mm]	l [mm]	d_s [mm]	[pcs]
SX 6 in bucket	507900	6	40	30	4 - 5	3200
SX 8 in bucket	507904	8	50	40	4,5 - 6	1200
SX 10 in bucket	507909	10	70	50	6 - 8	720
SX 12 in bucket	523269	12	80	60	8 - 10	350

6

Technical data

Assortment boxes



Assortment box UX / SX



Box SX 5/6/8



Box UX / SX-S



Profi-Box

Item	Item No.	Contents	Sales unit [pcs]
Assortment box UX / SX	040991	60 plugs SX 6 x 30, 50 plugs SX 8 x 40, 20 plugs SX 10 x 50, 60 plugs UX 5 x 30 R, 40 plugs UX 6 x 50 R, 50 plugs UX 8 x 50 R, 10 plugs UX 10 x 60 R	1
Box SX 5/6/8	030191	100 plugs SX 5 x 25, 100 plugs SX 6 x 30, 100 plugs SX 8 x 40	1
Meister-Box SX-plug	041648	German version: 60 plugs SX 6 x 30, 60 plugs SX 8 x 40, 12 plugs SX 10 x 50	1
Box UX / SX-S	093181	50 plugs UX 6 x 35, 50 screws 4,5 x 45, 50 plugs SX 6 x 30, 50 screws 4,5 x 40, 25 plugs UX 8 x 50, 25 screws 5 x 65, 25 plugs SX 8 x 40, 25 screws 5 x 55	1
Meister-Box SX + screws	513777	German version: 50 Expansion plugs SX 6 x 30, 30 Expansion plugs SX 8 x 40, 50 Chipboard screws 4,5 x 40, 30 Chipboard screws 5 x 55	1
Profi-Box SX + screws	518525	International version: 50 Expansion plugs SX 6 x 30, 30 Expansion plugs SX 8 x 40, 50 Chipboard screws 4,5 x 40, 30 Chipboard screws 5 x 55	1
Profi-Box SX	518524	International version: 60 Expansion plugs SX 6 x 30, 60 Expansion plugs SX 8 x 40, 12 Expansion plugs SX 10 x 50	1

Loads

Expansion plug SX

Highest recommended loads¹⁾ for a single anchor.

The given loads are valid for wood screws with the specified diameter.

Type		SX 4 x 20	SX 5 x 25	SX 6 x 30 SX 6 x 50	SX 8 x 40 SX 8 x 65	SX 10 x 50	SX 10 x 80	SX 12 x 60	SX 14 x 70	SX 16 x 80
Wood screw diameter	[mm]	3	4	5	6	8	8	10	12	12
Min. edge distance concrete c_{min}	[mm]	20	25	35	40	50	50	65	100	120
Recommended loads in the respective base material F_{rec} ²⁾										
Concrete \geq C20/25	[kN]	0.16	0.30	0.65	0.70	1.20	1.20	1.70	2.00	2.60
Solid brick \geq Mz 12	[kN]	0.11	0.25	0.30	0.60	0.65	1.20	0.70	0.80	0.90
Solid sand-lime brick \geq KS 12	[kN]	0.17	0.30	0.50	0.60	1.20	1.20	1.70	2.00	2.60
Aerated concrete \geq AAC 2 (G2)	[kN]	0.03	0.03	0.03	0.04	0.09	0.20	0.14	0.30	0.40
Aerated concrete \geq AAC 4 (G4)	[kN]	0.07	0.09	0.09	0.14	0.30	0.60	0.45	0.50	0.60
Vertically perforated brick \geq Hlz 12 ($\rho \geq 1.0 \text{ kg/dm}^3$)	[kN]	0.13	0.07	0.07	0.17	0.17	0.50	0.26	0.40	0.60
Perforated sand-lime brick \geq KSL 12	[kN]	0.15	0.17	0.30	0.35	0.30	0.80	0.35	0.30	0.40
Gypsum block	[kN]	-	-	-	0.26	0.37	-	1.00	1.00	-

¹⁾ Required safety factors are considered.

²⁾ Valid for tensile load, shear load and oblique load under any angle.

Expansion plug SX Green

The powerful nylon plug with 4-way expansion



Mirror fixings



Wall consoles

6

Applications

- Lighting
- Wardrobes
- Motion detectors
- Skirting
- Light shelves
- Mirror cabinets
- Letter boxes
- TV consoles
- Trellis
- Folding shutters
- Bath and toilet installations

Advantages

- Produced with at least 50% renewable raw materials and therefore particularly environmentally friendly.
- Just as effective, secure and durable as regular SX plugs.
- The powerful 4-way expansion provides optimum force transmission in the building material, thus enabling high load values and security.
- The anti-rotation lock prevents the plug from spinning in the drill hole.
- The expansion-free plug neck prevents the creation of expansion forces on the material whilst screwing in the screw. This helps to prevent damage to tiles and plaster.
- Fast and easy push-through installation reduces installation time.

Certificates



Building materials

- Concrete
- Vertically perforated brick
- Hollow blocks made from lightweight concrete
- Cavity floor slabs made from bricks and concrete
- Perforated sand-lime brick
- Solid sand-lime brick
- Natural stone with dense structure
- Aerated concrete
- Solid panel made from gypsum
- Solid brick made from lightweight concrete
- Solid brick

Functioning

- The SX GREEN is suitable for pre-positioned and push-through installation.
- When screwing in the screw, the SX GREEN expands in four directions, thus providing a secure anchoring in the building material.
- The required screw length is given by the plug length + fixture thickness + 1 x screw diameter.
- Suitable for wood, chipboard and spacing screws.

Installation SX Green

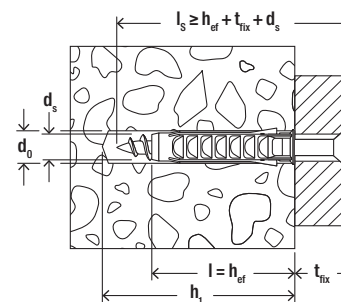
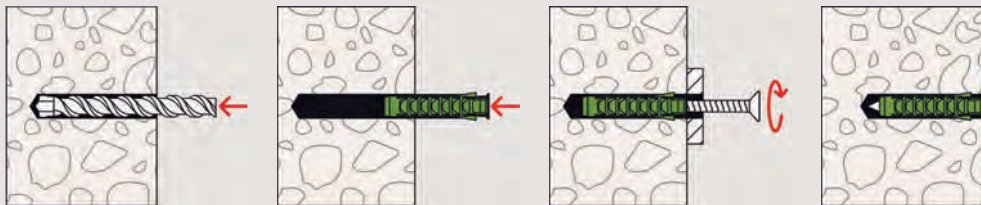

6

Technical data

Expansion plug SX Green



with rim

with greater anchorage depth, without rim

with rim and screw

Item	With rim	Without rim and large anchorage depth	With rim and screw	Drill hole diameter	Min. drill hole depth	Anchor length	Max. fixture thickness	Wood and chip-board screws	Sales unit
	Item No.	Item No.	Item No.	d_0 [mm]	h_1 [mm]	l [mm]	t_{fix} [mm]	$d_s / d_s \times l_s$ [mm]	[pcs]
SX Green 5 x 25	524859	—	—	5	35	25	—	3 - 4	90
SX Green 6 x 30	524860	—	—	6	40	30	—	4 - 5	90
SX Green 6 x 30	—	—	524866	6	45	30	5	4,5 x 40	45
SX Green 6 x 50	—	524861	—	6	60	50	—	4 - 5	90
SX Green 8 x 40	524862	—	—	8	50	40	—	4,5 - 6	90
SX Green 8 x 40	—	—	524867	8	60	40	15	5 x 55	45
SX Green 8 x 65	—	524863	—	8	75	65	—	4,5 - 6	45
SX Green 10 x 50	524864	—	—	10	60	50	—	6 - 8	45
SX Green 12 x 60	524865	—	—	12	80	60	—	8 - 10	20

Loads

Expansion plug SX Green

Highest recommended loads¹⁾ for a single anchor.

The given loads are valid for wood screws with the specified diameter.

Type		SX Green 5 x 25	SX Green 6 x 30 SX Green 6 x 50	SX Green 8 x 40 SX Green 8 x 65	SX Green 10 x 50	SX Green 12 x 60	
Wood screw diameter	[mm]	4	5	6	8	10	
Min. edge distance concrete c_{min}	[mm]	25	35	40	50	65	
Recommended loads in the respective base material F_{rec} ²⁾							
Concrete	≥ C20/25	[kN]	0.30	0.65	0.70	1.20	1.70
Solid brick	≥ Mz 12	[kN]	0.25	0.30	0.60	0.65	0.70
Solid sand-lime brick	≥ KS 12	[kN]	0.30	0.50	0.60	1.20	1.70
Aerated concrete	≥ AAC 2 (G2)	[kN]	0.03	0.03	0.04	0.09	0.14
Aerated concrete	≥ AAC 4 (G4)	[kN]	0.09	0.09	0.14	0.30	0.45
Vertically perforated brick	≥ Hlz 12 ($\rho \geq 1.0 \text{ kg/dm}^3$)	[kN]	0.07	0.07	0.17	0.17	0.26
Perforated sand-lime brick	≥ KSL 12	[kN]	0.17	0.30	0.35	0.30	0.35
Gypsum block		[kN]	-	-	0.26	0.37	1.00

¹⁾ Required safety factors are considered.

²⁾ Valid for tensile load, shear load and oblique load under any angle.

Expansion plug S

The installation-friendly nylon plug with 2-way expansion



Small shelves



Signs

6

Applications

- Pictures
- Lighting
- Skirting
- Light shelves
- Mirror cabinets
- Letter boxes
- Motion detectors
- Information boards
- Curtain rails
- Electrical installations

Advantages

- The rimless plug sleeve allows for the plug to be set as deep as required below the plaster to the bearing substrate to achieve the maximum load-bearing capacity.
- As the plug only expands in two directions, it is possible to direct the expansion forces so that they run parallel to the edge of the building material by turning

the plug. This allows for smaller edge distances.

- The slimline plug geometry makes it easy to push the plug into the drill hole. For a fast and simple installation.
- The anti-rotation lock prevents the plug rotating in the drill hole, thus guaranteeing a high level of installation safety.

Certificates



Building materials

- Concrete
- Solid sand-lime brick
- Natural stone with dense structure
- Solid brick made from lightweight concrete
- Solid brick

Functioning

- The expansion plug S is suitable for pre-positioned and push-through installation.
- When turning in the screw, the expansion plug S expands in two directions, thus providing a secure anchoring in the building material.
- The required screw length is given by the plug length + plaster and/or insulation material thickness + fixture thickness + 1 x screw diameter.
- Suitable for wood and chipboard screws.
- The edge distance must be at least one plug length.
- For installations close to the edge, turn the plug so that the expansion force acts parallel to the edge.

Installation plug S

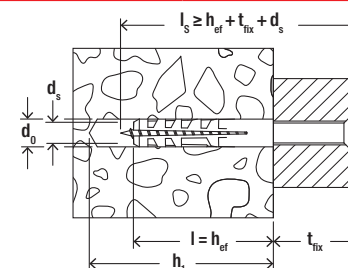
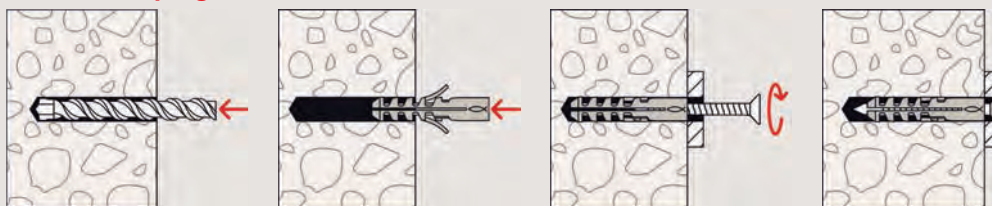

6

Technical data

Expansion plug S



S

Item	Standard	Double-pack	Drill hole diameter	Anchor length	Min. drill hole depth	Wood and chipboard screws	Sales unit
	Item No.	Item No.	d_0 [mm]	l [mm]	h_1 [mm]	d_s [mm]	[pcs]
S 4	050104	—	4	20	25	2 - 3	200
S 5	050105	—	5	25	35	3 - 4	100
S 5	—	050124	5	25	35	3 - 4	200
S 6	050106	—	6	30	40	4 - 5	100
S 6	—	050125	6	30	40	4 - 5	200
S 8	050108	—	8	40	55	4,5 - 6	100
S 8	—	050126	8	40	55	4,5 - 6	200
S 10	050110	—	10	50	70	6 - 8	50
S 10	—	050127	10	50	70	6 - 8	100
S 12	050112	—	12	60	80	8 - 10	25
S 14	050114	—	14	75	90	10 - 12	20
S 16	050116	—	16	80	100	12 (1/2")	10
S 20	050120	—	20	90	120	16	5

Technical data

Expansion plug S in bucket



S in bucket

Item	Item No.	Drill hole diameter	Min. drill hole depth	Anchor length	Wood and chipboard screws	Sales unit
		d_0 [mm]	h_1 [mm]	l [mm]	d_s [mm]	[pcs]
S 6 in bucket	508024	6	40	30	4 - 5	3200
S 8 in bucket	508025	8	55	40	4,5 - 6	1400

Technical data

Assortment boxes



ST 1

Box S6/8/10

Item	Item No.	Contents	Sales unit [pcs]
ST 1 S8 S	060510	34 plugs S 8, 34 countersunk wood screws SH 5 x 60	1
ST 1 S6 S	060509	50 plugs S 6, 50 countersunk wood screws SH 4,5 x 45	1
ST 1 S6/8	060499	50 plugs S 6, 30 plugs S 8	1
Box S 6.8.10	060515	100 plugs S 6, 100 plugs S 8, 25 plugs S 10	1
Box empty	060500	—	1

Loads

S-Plug

Highest recommended loads¹⁾ for a single anchor.

The given loads are valid for wood screws with the specified diameter.

Type		S 4	S 5	S 6	S 8	S 10	S 12	S 14	S 16	S 20	
Wood screw diameter	[mm]	3	4	5	6	8	10	12	12	16	
Min. edge distance concrete c_{min}	[mm]	20	25	30	40	50	60	70	80	100	
Recommended loads in the respective base material F_{rec} ²⁾											
Concrete	≥ C20/25	[kN]	0.16	0.28	0.40	0.60	1.10	1.50	1.85	2.26	3.88
Solid brick	≥ Mz 12	[kN]	0.14	0.24	0.28	0.50	³⁾	³⁾	³⁾	³⁾	³⁾
Solid sand-lime brick	≥ KS 12	[kN]	0.14	0.24	0.28	0.55	³⁾	³⁾	³⁾	³⁾	³⁾
Aerated concrete	≥ AAC 4 (G4)	[kN]	³⁾	³⁾	0.05	0.07	0.16	0.28	0.40	³⁾	³⁾
Gypsum block		[kN]	³⁾	³⁾	³⁾	0.15	0.23	0.37	0.60	³⁾	³⁾

¹⁾ Required safety factors are considered.

²⁾ Valid for tensile load, shear load and oblique load under any angle.

³⁾ Due to that the failure of the substrate varies too much no reproducible values can be given.

Threaded rod plug RodForce FGD

The economical hammerset plug - easy and quick fixing of threaded rods



Suspended ceilings

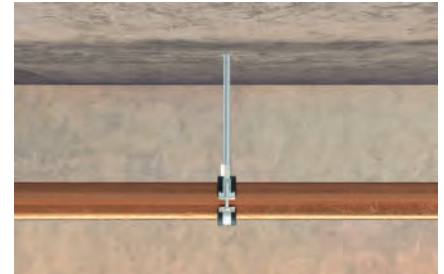

Single pipe suspension

6

Applications

- Suspension for individual pipes
- Plumbing and heating fixings
- Cable and pipe clips
- Suspended ceilings
- Ceiling lights
- Consoles
- Mounting rails

Advantages

- The innovative plug geometry allows quick and easy installation of the threaded rod with a few hammer blows.
- The short plug length prevents reinforcement hits and guarantees a secure utilization in reinforced concrete.
- The teeth inside the plug allow standard, metric threads to be held: This saves a large assortment of stud screws.
- Installation without special tools: The only thing needed to set the plug is a hammer.

- Visible edge of the plug serves as visual setting check and guarantees correct setting.
- The visible edge of the plug serves as visual setting check and guarantees correct setting.
- Easy to check and adjust: To check the setting depth, the closed plug tip is used as a stop point. This predetermined break point also allows the threaded rod to be hammered-in deeper.

Building materials

- Concrete
- Solid sand-lime brick
- Solid brick

Functioning

- When hammering-in the threaded rod, the plug expands in four directions as a result of the conical inner geometry.
- The plug is set using pre-positioned installation and this is possible in two different ways: Pre-installation of the threaded rods in the plug with both being hammered into the wall together or pre-inserting of the RodForce into the drill hole followed by hammering-in of the threaded rod.
- The teeth inside the plug mechanically interlock the metric thread securely with the threaded rod.
- The unique elements on the outside of the plug brace against the wall of the drill hole.

Installation within the system

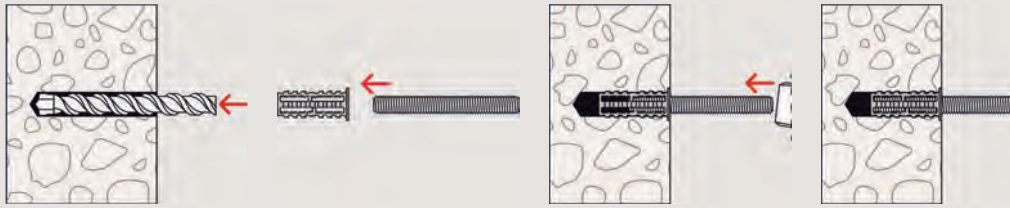

Installation with individual components



6

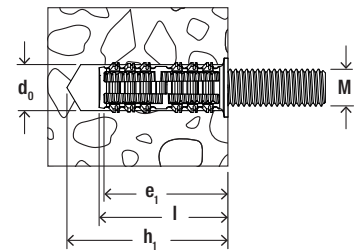

Technical data

Threaded rod plug RodForce FGD



RodForce FGD

Item	Item No.	Drill diameter	Min. drill hole depth	Anchor length	Min. drop-in penetration	Threaded rod Ø x length [mm]	Sales unit [pcs]
		d_0 [mm]	h_1 [mm]	l [mm]	e_1 [mm]		
RodForce FGD 10 M6	542106	10	40	35	33	—	50
RodForce FGD 10 M6 TR 50	542107	10	40	35	33	M 6 x 50	25
RodForce FGD 10 M6 TR 60	542108	10	40	35	33	M 6 x 60	25
RodForce FGD 10 M6 TR 80	542109	10	40	35	33	M 6 x 80	25
RodForce FGD 12 M8	542111	12	40	35	33	—	50
RodForce FGD 12 M8 TR 50	542112	12	40	35	33	M 8 x 50	25
RodForce FGD 12 M8 TR 60	542113	12	40	35	33	M 8 x 60	25
RodForce FGD 12 M8 TR 80	542114	12	40	35	33	M 8 x 80	25

Loads

Threaded rod plug RODFORCE FGD

Highest recommended loads¹⁾ for a single anchor.

The given loads are valid for machine screws or threaded rods with the specified thread size.

Type		RodForce FGD M 6	RodForce FGD M 8
Thread size		M 6	M 8
Recommended loads in the respective base material F_{rec} ²⁾			
Concrete	≥ C20/25	[kN] 0.31	0.36
Solid brick	≥ Mz 12	[kN] 0.31	0.36
Solid sand-lime brick	≥ KS 12	[kN] 0.19	0.33

¹⁾ Required safety factors are considered.

²⁾ Valid for tensile load, shear load and oblique load under any angle.

Metal expansion anchor FMD

The metal anchor for wood and chipboard screws



Pipes



Gas meters

6

Applications

- Gas pipes
- Water pipes
- Cable and pipe clips

Advantages

- The metal expansion anchor FMD is especially suited to applications in installation technology.
- The external teeth expand in the building material, thus ensuring a high load-bearing capacity.

- The ribbed internal geometry of the FMD is suitable for wood and chipboard screws, and makes it possible to guide the screw securely. This offers increased installation safety, and enables a broad range of applications.

Building materials

- Concrete
- Vertically perforated brick
- Hollow blocks made from lightweight concrete
- Cavity floor slabs made from bricks and concrete
- Perforated sand-lime brick
- Solid sand-lime brick
- Natural stone with dense structure
- Aerated concrete
- Solid brick made from lightweight concrete
- Solid panel made from gypsum

Functioning

- The FMD is suitable for pre-positioned installation.
- Inserting the screw causes the FMD to expand, and the metal teeth fix the anchor securely in the building material.
- The required (stud) screw length is given by: Anchor length + plaster and/or insulation layer thickness + fixture thickness or installation spacing + 1 x screw diameter.
- Suitable for wood and chipboard screws.
- The drill diameter is relative to the compressive strength of the building material. The higher the compressive strength, the greater the drill diameter. The 6x32 and 8x38 sizes can be hammered directly into low-strength aerated concrete without the need for pre-drilling.

Installation FMD

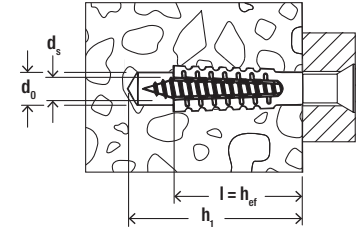
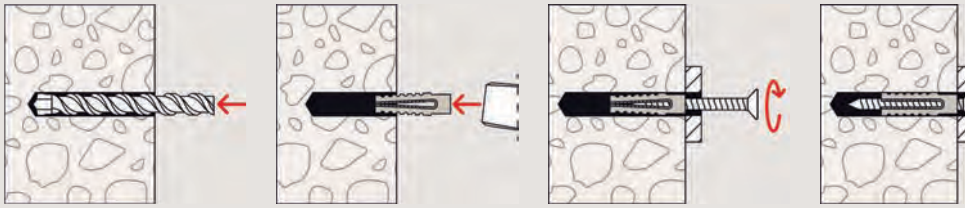

Technical data

Metal expansion anchor FMD



FMD

Item	Item No.	Drill hole diameter d_0 [mm]	Min. drill hole depth h_1 [mm]	Anchor length l [mm]	Screw diameter d_s [mm]	Sales unit [pcs]
FMD 6 x 32	061224 ¹⁾	6 - 7	38	32	5 - 6	100
FMD 8 x 38	061225 ¹⁾	10 - 12	46	38	6 - 8	100
FMD 8 x 60	061226 ¹⁾	10 - 12	68	60	6 - 8	50
FMD 10 x 60	061209 ¹⁾	12 - 14	68	60	8 - 10	50

¹⁾ The drill diameter is relative to the substrate compressive strength. Generally, the higher the compressive strength, the greater the drill diameter.

Recommended drill hole diameter [mm]

Type		FMD 6 x 32	FMD 8 x 38	FMD 8 x 60	FMD 10 x 60
Concrete	C 20/25	7	10	12	14
Aerated concrete	ACC 4	6	10	10	12
Vertically perforated brick	Hlz 12	7	10	10	12

Loads

Metal expansion fixing FMD

Highest recommended loads¹⁾ for a single anchor.

The given loads are valid for wood screws with maximum diameter.

Type		FMD 8 x 38	FMD 8 x 60	FMD 10 x 60
Wood screw diameter	[mm]	8	8	10
Recommended loads in the respective base material F_{rec} ²⁾				
Aerated concrete	≥ AAC 2 (G2)	[kN] 0.20	0.30	0.40
Aerated concrete	≥ AAC 4 (G4)	[kN] 0.30	0.40	0.60

¹⁾ Required safety factors are considered.

²⁾ Valid for tensile load, shear load and oblique load under any angle.

Expansion plug M-S

The expansion plug for metric screws and threaded bolts

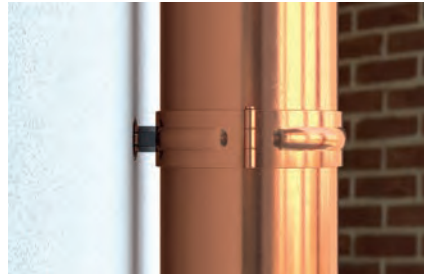

Downpipes



Folding shutters

6

Applications

- Handles
- Folding shutters
- Trellis
- Downpipes
- Stand-off installation
- Window fittings
- Gratings

Advantages

- The internal geometry of the M-S allows for the use of standard metric screws or threaded rods for the ideal adaptation to suit the intended use.
- The rimless plug sleeve allows for the plug to be set as deep as required below the plaster to the bearing substrate to achieve the maximum load-bearing capacity.
- As the plug only expands in two directions, it is possible to direct the expansion forces so that they run parallel to the edge of the building material by turning the plug. This allows for smaller edge distances.
- The slimline plug geometry makes it easy to push the plug into the drill hole, for a fast and simple installation.

Certificates



Building materials

- Concrete
- Cavity floor slabs made from bricks and concrete
- Perforated sand-lime brick
- Solid sand-lime brick
- Natural stone with dense structure
- Solid brick made from lightweight concrete
- Solid brick
- Solid panel made from gypsum
- Vertically perforated brick
- Aerated concrete

Functioning

- The M-S is suitable for pre-positioned and push-through installation.
- When turning in the screw, the M-S expands in two directions, thus providing a secure anchoring in the building material.
- The required screw length is given by: Plug length + plaster and/or insulation layer thickness + fixture thickness + 1 x screw diameter.
- Suitable for metric screws and threaded bolts.
- Chamfer the thread to make it easier to screw in screws and threaded rods.

Installation M-S

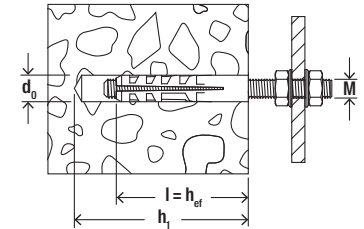
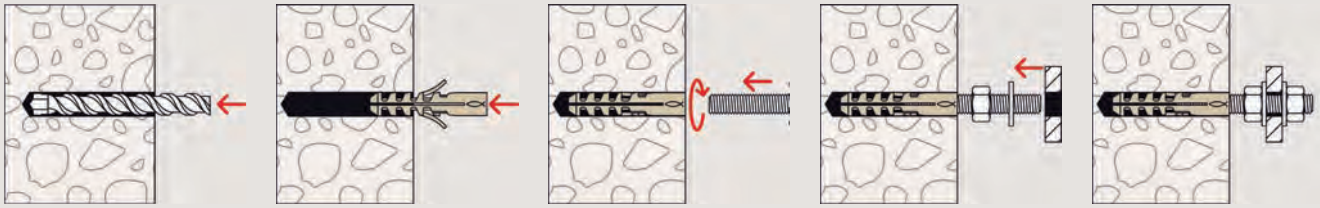

6

Technical data

Expansion plug M-S



M-S for metric screws

Item	Item No.	Drill hole diameter d_0 [mm]	Min. drill hole depth h_1 [mm]	Anchor length l [mm]	Thread M	Sales unit [pcs]
M 6 S	050152	8	55	40	M 6	100
M 8 S	050153	10	70	50	M 8	50
M 10 S	050154	14	90	70	M 10	20
M 12 S	050155	16	100	80	M 12	10

Loads

Anchor M-S

Highest recommended loads¹⁾ for a single anchor.
The given loads are valid for metric screws with the specified thread size.

Type		M 6 S	M 8 S	M 10 S	M 12 S
Thread size		M 6	M 8	M 10	M 12
Recommended loads in the respective base material $F_{rec}^{2)}$					
Concrete	C20/25	[kN] 0.30	0.54	0.66	1.06
Solid brick	Mz 12	[kN] 0.24	0.33	0.46	0.79
Solid sand-lime brick	KS 12	[kN] 0.24	0.33	0.43	0.71

¹⁾ Required safety factors are considered.

²⁾ Valid for tensile load, shear load and oblique load under any angle.

Anchor M

The powerful nylon expansion anchor with brass cone for metric threads



Plant construction



Protective grilles

6

Applications

- Machines
- Curbs
- Control boxes

Advantages

- The anchor's large external diameter helps to achieve a large applied load in the building material. This allows for maximum load-bearing capacity.
- The anchor's high expansion makes it insensitive to building material tolerances. This guarantees a simple and secure

installation.

- The internal thread allows for the use of standard metric screws or threaded rods, and for surface flush removal and reuse of the fixing point. This provides great flexibility.

Certificates



Building materials

- Concrete
- Natural stone with dense structure
- Solid brick
- Solid sand-lime brick
- Solid brick made from lightweight concrete
- Aerated concrete
- Solid panel made from gypsum
- Hollow blocks made from lightweight concrete

Functioning

- The M anchor is suitable for pre-positioned installation.
- Turning in the screw causes the internal brass cone to expand the M anchor, thus reliably anchoring it in the building material.
- The required screw length is given by anchor length + fixture thickness.
- Suitable for metric screws and threaded bolts.

Installation M

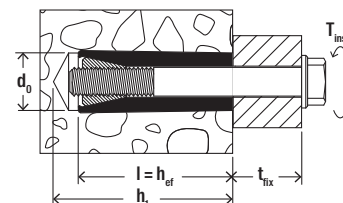
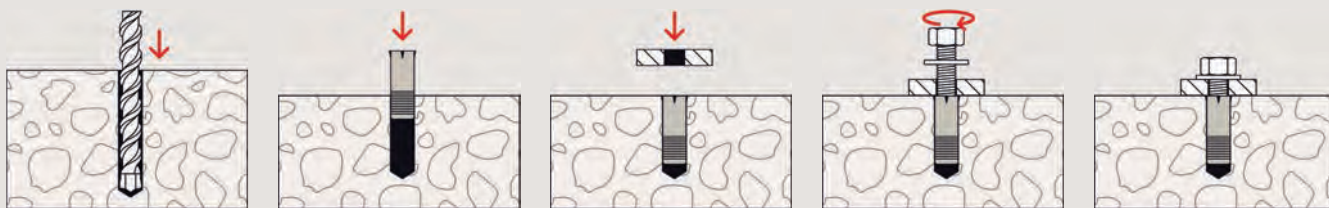

6

Technical data

Anchor M



M for metric screws

Item	Item No.	Drill hole diameter	Min. drill hole depth	Anchor length	Thread	Max. installation torque	Sales unit
		d_0 [mm]	h_1 [mm]	l [mm]	M	T_{inst} [Nm]	[pcs]
M 5	050505 ¹⁾	10	45	35	M 5	4	50
M 6	050506 ¹⁾	12	50	40	M 6	7	50
M 8	050508 ¹⁾	16	65	50	M 8	16	20
M 10	050510 ¹⁾	20	80	60	M 10	32	10
M 12	050512 ¹⁾	24	90	65	M 12	54	5

1) The given torque values apply to screws of strength class ≥ 5.8 .

Loads

Thread size

Highest recommended loads¹⁾ for a single anchor.
The given loads are valid for metric screws with the specified thread size.

Type		M 5	M 6	M 8	M 10	M 12
Thread size		M 5	M 6	M 8	M 10	M 12
Recommended loads in the respective base material F_{rec} ²⁾						
Concrete	$\geq C20/25$	[kN] 1.10	1.80	2.60	4.40	5.00

¹⁾ Required safety factors are considered.

²⁾ Valid for tensile load, shear load and oblique load under any angle.

Brass fixing MS

The brass expansion fixing with metric thread



6



Protective wall panels



Small shelves

Applications

- Cellar shelves
- Substructures made of wood and metal
- Boilers
- Aggregates
- Control boxes
- Curtain rails

Advantages

- The compact design of the brass fixing reduces the amount of drilling required, helping to ensure a fast installation.
- The special surface structure of the MS prevents the fixing from rotating in the drill hole. This provides increased instal-

lation safety.

- The internal thread allows for the use of standard metric screws or threaded rods, and for surface flush removal and reuse of the fixing point. This provides great flexibility.

Building materials

- Concrete
- Solid sand-lime brick
- Natural stone with dense structure
- Solid brick

Functioning

- The MS brass fixing is suitable for pre-positioned installation.
- Turning in the metric screw causes the front part of the brass fixing to expand, thus securely anchoring it in the substrate.
- Calculating screw length for flush fixing installation: Fixing length + fixture thickness = min. screw length.
- Suitable for metric screws and threaded bolts.

Installation MS

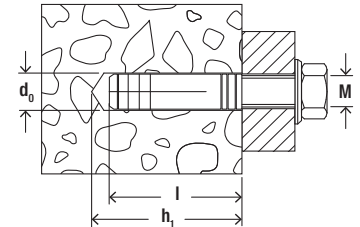
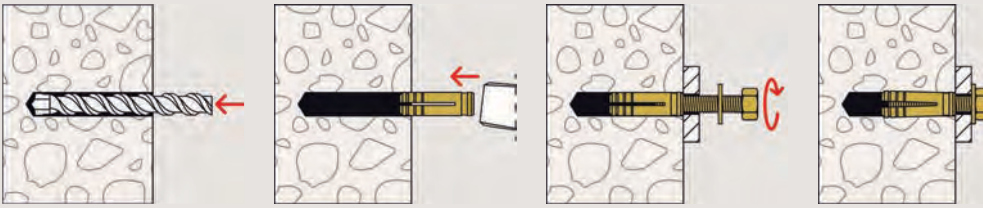

6

Technical data

Brass fixing MS



MS for metric screws

Item	Item No.	Drill hole diameter d_0 [mm]	Min. drill hole depth h_1 [mm]	Anchor length l [mm]	Thread $\emptyset \times$ length [mm]	Min. bolt penetration $l_{E,min}$ [mm]	Sales unit [pcs]
MS 4 x 15	026424	5	20	15	M 4	15	100
MS 5 x 18	026425	6	25	18	M 5	18	100
MS 6 x 22	078660	8	27	22	M 6	22	100
MS 8 x 28	078981	10	35	28	M 8	28	50
MS 10 x 32	078661	12	39	32	M 10	32	25
MS 12 x 37	078662	15	46	37	M 12	37	10
MS 16 x 43	078663	20	50	43	M 16	43	10

Loads

Brass fixing MS

 Highest recommended loads¹⁾ for a single anchor.

The given loads are valid for metric screws with the specified thread size.

Type		MS 4 x 15	MS 5 x 18	MS 6 x 22	MS 8 x 28	MS 10 x 32	MS 12 x 37	MS 16 x 43	
Thread size		M 4	M 5	M 6	M 8	M 10	M 12	M 16	
Recommended loads in the respective base material F_{rec} ²⁾									
Concrete	\geq C20/25	[kN]	0.25	0.40	0.65	1.10	1.60	2.20	3.30
Solid brick	\geq Mz 12	[kN]	0.20	0.35	0.55	0.90	1.30	1.60	2.30

¹⁾ Required safety factors are considered.

²⁾ Valid for tensile load, shear load and oblique load under any angle.

Aircrete anchor GB

The special plug for different fixings in aerated concrete

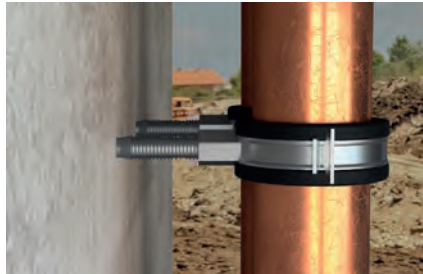

Pipes



Trellis

6

Applications

- Light cable trays
- Pipelines
- Guard rails
- Façade and roof constructions made of wood and metal
- Light canopy brackets
- Letter boxes
- Trellis

Certificates



Advantages

- The general building approval guarantees approved safety for use in safety-relevant applications.
- The spiral-shaped outer ribs cut a positive fit in the soft building material, thus ensuring the best pressure distribution and load-bearing capacity.
- Can be applied with a hammer - there

Building materials

Approved for (GB 10) resp. suitable for (GB 8 and GB 14):

- Aerated concrete \geq AAC 2
- Also suitable for:
- Aerated concrete and ceiling panels of compressive strength \geq 3,3

is no need for special tools, thus saving time and money for the installation.

- The GB can also be used safely outside (e.g. in façade installation) when combined with the approved fischer safety screw in A4.

Functioning

- The GB is suitable for pre-positioned installation.
- The spiral-shaped outer ribs ensure a positive fit connection between the building material and anchor.
- The required screw length is given by: Anchor length + fixture thickness + 1 x screw diameter.
- The GB 10 must be used with fischer safety screws to fulfil the approval and to achieve the maximum load-bearing capacity.
- Use rotary drilling to create the drill hole
- Can be used in unplastered aerated concrete

Installation GB

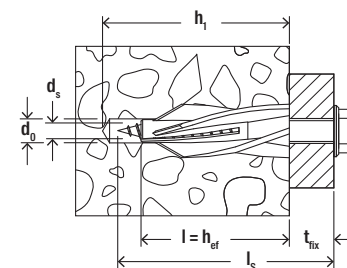
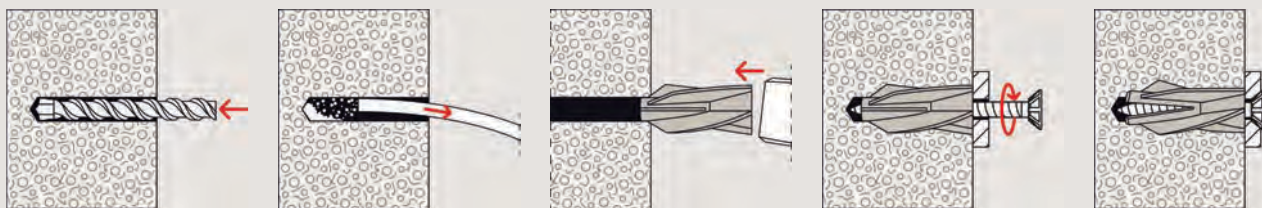

6

Technical data

Aircrete anchor GB



GB

Item	Item No.	Approval DIBt	Drill hole diameter	Min. drill hole depth	Plug length = min. anchorage depth	fischer safety screw	Sales unit
			d_0 [mm]	h_1 [mm]	$l = h_{ef}$ [mm]	$d_s \times l_s$ [mm]	[pcs]
GB 8	050491	—	8	60	50	5	25
GB 10	050492	●	10	65	55	7	20
GB 14	050493	—	14	90	75	10	10

fischer Safety srew for GB

Type	Usable length		Screw dimension* $\emptyset \times l_s$	Zinc plated and passivated steel		Stainless steel, corrosion resistance class III, e. g. A4	
	min. t_{fix} [mm]	max. t_{fix} [mm]		Countersunk head, TX star recess drive Art.-No.	Hexagonal head Art.-No.	Countersunk head, TX star recess drive Art.-Nr.	Hexagonal head Art.-Nr.
GB 8	5	30	5 x 85	089230 ¹⁾		089240 ¹⁾	
GB 10	0	5	7 x 67		80404		
	5	25	7 x 87	89170	80405	89244	80261
	25	45	7 x 107	89172			
	40	58	7 x 120	89174	80407		
	60	78	7 x 140	89176	80408		
GB 14	85	105	7 x 167	89178			
	0	10	10 x 95		80412		
	0	20	10 x 105	89186	80413		80271
	35	55	10 x 140	89188	80415		
	60	80	10 x 165		80416		

¹⁾ Cross drive recess Z.²⁾ Further sizes on request.

Loads

Aircrete anchor GB					
Permissible or recommended loads ^{1) 2)} for a single anchor in aerated concrete.					
Type		GB 10 ²⁾	GB 8 ³⁾	GB 10 ³⁾	GB 14 ³⁾
Screw diameter		[mm] 7	5	6	10
Minimum spacing ⁴⁾	s _{min}	[mm] 100	150 (100) ⁶⁾	150 (100) ⁶⁾	300 (200) ⁶⁾
Minimum edge distance ⁵⁾	c _{min}	[mm] 100	100 (75) ⁶⁾	100 (75) ⁶⁾	200 (150) ⁶⁾
Minimum member thickness	h _{min}	[mm] 120	75	120	200
Nominal embedment depth	h _{nom}	[mm] 55	50	55	75
Load in the respective base material		Permissible loads F _{perm} ⁷⁾	Recommended loads F _{rec} ⁸⁾		
AAC 2	ρ ≥ 0.35 [kg/dm ³]	[kN] 0.21	0.18	0.20	0.40
AAC 4	ρ ≥ 0.50 [kg/dm ³]	[kN] 0.54 (0.71) ⁹⁾	0.40	0.50	0.90

¹⁾ Required safety factors are considered. Valid for tension load, shear load and oblique load under any angle.

²⁾ In case of the design of the GB 10 for tension, shear and bending the complete approval Z-21.2-123 has to be considered.

³⁾ Not part of the approval.

⁴⁾ Minimum possible axial spacing while reducing the permissible load.

⁵⁾ Minimum possible edge distance.

⁶⁾ Values in brackets apply to AAC 2.

⁷⁾ Value only applies in connection with GB 10 and fischer safety screw according to approval Z-21.2-123.

⁸⁾ Values are valid in combination with wood screws acc. DIN 571.

⁹⁾ The values in brackets are decisive for member thickness ≥ 150 mm.

Aircrete anchor GB Green

Secure in aerated concrete



Radiators



Trellis

6

Applications

- Pipelines
- Letter boxes
- Trellis
- Handles
- Gratings
- Electrical installations

Certificates



Advantages

- Produced with at least 50% renewable raw materials and therefore particularly environmentally friendly.
- The spiral-shaped outer ribs cut a positive fit in the soft building material, thus

ensuring best pressure distribution and load-bearing capacity.

- Can be applied with a hammer – there is no need for special tools, thus saving time and money for the installation.

Building materials

- Aerated concrete \geq AAC 2
- Aerated concrete and ceiling panels of compressive strength \geq 3.3

Functioning

- The aircrete anchor GB GREEN is suitable for pre-positioned installation.
- The spiral-shaped outer ribs cut a positive fit into the soft building material when knocked in, thus ensuring optimal pressure distribution and load-bearing capacity.
- The required screw length is given by the plug length + fixture thickness + 1 x screw diameter.
- Rotary drilling of the hole is required.
- Can be used in unplastered aerated concrete.

Installation GB Green

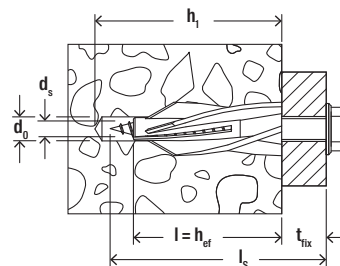
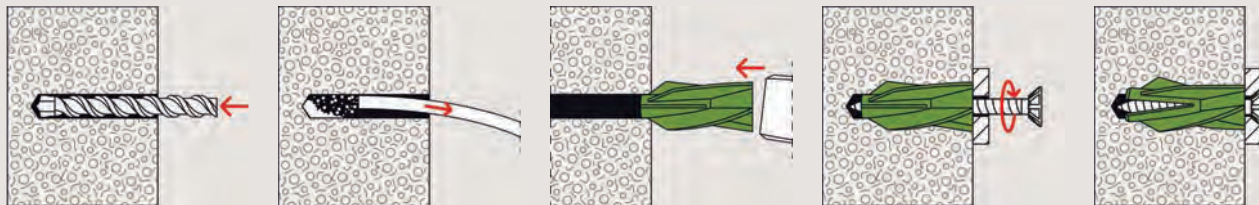

6

Technical data

Aircrete anchor GB Green



GB Green

Item	Item No.	Drill hole diameter	Min. drill hole depth	Plug length = min. anchorage depth	fischer safety screw	Sales unit
		d_0 [mm]	h_1 [mm]	$l = h_{ef}$ [mm]	$d_s \times l_s$ [mm]	[pcs]
GB Green 8	524870	8	60	50	5	20
GB Green 10	524871	10	65	55	7	18

fischer Safety srew for GB

Type	Usable length		Screw dimension*	Zinc plated and passivated steel		Stainless steel, corrosion resistance class III, e. g. A4	
	min. t_{fix} [mm]	max. t_{fix} [mm]		Countersunk head, TX star recess drive Art.-No.	Hexagonal head Art.-No.	Countersunk head, TX star recess drive Art.-Nr.	Hexagonal head Art.-Nr.
GB 8	5	30	5 x 85	089230 ¹⁾		089240 ¹⁾	
GB 10	0	5	7 x 67		80404		
	5	25	7 x 87	89170	80405	89244	80261
	25	45	7 x 107	89172			
	40	58	7 x 120	89174	80407		
	60	78	7 x 140	89176	80408		
GB 14	85	105	7 x 167	89178			
	0	10	10 x 95		80412		
	0	20	10 x 105	89186	80413		80271
	35	55	10 x 140	89188	80415		
	60	80	10 x 165		80416		

¹⁾ Cross drive recess Z.

²⁾ Further sizes on request.

Loads

Aircrete anchor GB Green

Recommended loads¹⁾ for a single anchor in aerated concrete.

Load values apply when using fischer safety screws²⁾ according to selection table.

Type			GB Green 8	GB Green 10
Diameter fischer safety screw		[mm]	5	7
Minimum spacing ³⁾	s_{min}	[mm]	150 (100) ⁵⁾	100
Minimum edge distance ⁴⁾	c_{min}	[mm]	100 (75) ⁵⁾	100
Minimum member thickness	h_{min}	[mm]	75	120
Nominal embedment depth	h_{nom}	[mm]	50	55
Recommended load (F_{rec}) in the respective base material				
AAC 2	$\rho \geq 0,35$ [kg/dm ³]	[kN]	0.18	0.21
AAC 4	$\rho \geq 0,50$ [kg/dm ³]	[kN]	0.40	0.54 (0,71) ⁶⁾

¹⁾ Required safety factors are considered. Valid for tension load, shear load and oblique load under any angle.

²⁾ Galvanised steel (gvz) and stainless steel (R).

³⁾ Minimum possible axial spacing while reducing the permissible load.

⁴⁾ Minimum possible edge distance.

⁵⁾ Values in brackets apply to AAC 2.

⁶⁾ The values in brackets are decisive for member thickness ≥ 150 mm.

Turbo aircrete anchor FTP K

The versatile nylon anchor for aerated concrete



External lighting



Radiators

6

Applications

- Pictures
- Lighting
- Shelves
- Mirror cabinets
- Letter boxes
- Signs
- Motion detectors
- Cable and pipe clips
- Stand-off installations

Advantages

- The FTP K is suitable for both wood screws and metric screws, and thus offers flexibility in screw choice.
- The spiral-shaped outer thread taps itself into the soft aerated concrete with a positive fit, thus ensuring a secure hold.
- Setting with the FTP EK setting tool requires only a small amount of force. For a convenient installation.
- The special geometry allows for an almost expansion-force-free anchoring. This allows for small edge and spacing distances, and avoids splitting in the case of plastered surfaces.

Certificates



Building materials

- Aerated concrete
- Solid panel made from gypsum

Functioning

- The FTP K is suitable for pre-positioned installation.
- Set the FTP K with setting tool FTP EK. The aircrete anchor taps itself into the aerated concrete with a positive fit during the installation process.
- Suitable for wood and metric screws with diameter 4 to 10 mm.

Installation FTP

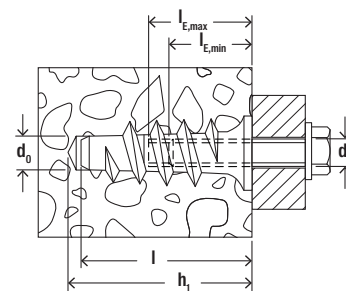
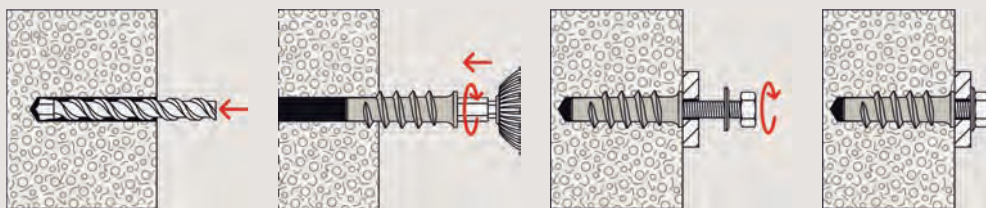

Technical data

Turbo aircrete anchor FTP K



FTP K (nylon)

Item	Item No.	Drill hole diameter d_0 [mm]	Min. drill hole depth h_1 [mm]	Anchor length l [mm]	Woodscrew diameter d_s [mm]	Metric screw M	Min. bolt penetration $l_{E,min}$ [mm]	Max. bolt penetration $l_{E,max}$ [mm]	Sales unit [pcs]
FTP K 4	078411 ¹⁾	8 - (10)	60	50	4 - 4,5	M 4	35	60	25
FTP K 6	078412 ¹⁾	8 - (10)	60	50	5 - 6	M 5 - 6	40	60	25
FTP K 8	078413 ¹⁾	10 - (12)	70	60	7 - 8	M 8	45	70	25
FTP K 10	078414 ¹⁾	12 - (14)	80	70	9 - 10	M 8 - 10	50	80	10

1) Values in brackets for drill hole diameter apply for aerated concrete, compressive strength of 5,0 N/mm² or higher.

Accessories

Setting tool FTP EK



FTP EK 4/6

FTP EK 8

FTP EK 10

Item	Item No.	Match	Sales unit [pcs]
FTP EK 4/6	090990	FTP K4 / FTP K6	1
FTP EK 8	090991	FTP K8	1
FTP EK 10	090992	FTP K10	1

Loads

Turbo aircrete anchor FTP K

Highest recommended loads¹⁾ for a single anchor in aerated concrete and gypsum blocks.
The given loads are valid for screws with the specified diameter.

Type		FTP K 4	FTP K 6	FTP K 8	FTP K 10	
Screw diameter	[mm]	4	5 - 6	8	8 - 10	
Min. edge distance c_{min}	[mm]	100	100	150	200	
Recommended loads in the respective base material F_{rec} ²⁾						
Aerated concrete	ACC 2 ($\geq 2,5 \text{ N/mm}^2$)	[kN]	0.15	0.20	0.30	0.40
Aerated concrete	ACC 4 ($\geq 5,0 \text{ N/mm}^2$)	[kN]	0.25	0.30	0.40	0.50
Gypsum block		[kN]	-	-	0.29	0.54

¹⁾ Required safety factors are considered.

²⁾ Valid for tensile load, shear load and oblique load under any angle.

Turbo aircrete anchor FTP M

The metal anchor for metric screws for aerated concrete



Shelves



Wall consoles

6

Applications

- Pictures
- Lighting
- Shelves
- Mirror cabinets
- Curtain rails
- Cable and pipe clips
- Stand-off installations
- Radiators
- TV consoles

Advantages

- The Allen key chuck makes it possible to set the FTP M without the need for a special setting tool. This allows for a simple installation.
- The FTP M achieves a very high load-bearing capacity in aerated concrete for increased safety.
- The spiral-shaped outer thread taps itself

- into the aerated concrete with a positive fit. This means that it can be set without the need for much force.
- The special geometry allows for an almost expansion-force-free anchoring. This allows for small edge and spacing distances, and avoids splitting in the case of plastered surfaces.

Building materials

- Aerated concrete
- Solid panel made from gypsum

Functionality

- The FTP M is suitable for pre-positioned installation.
- The aircrete anchor taps itself into the aircrete with a positive fit during the installation process.
- Suitable for metric screws with diameter 6 to 10 mm.
- For installation with a hexagon socket: Size of the hexagon socket corresponds to screw diameter, e.g. FTP M6 is installed with hexagon socket size 6.
- For installation with cordless screwdriver: use a low torque and use the correct 6-kt bit FTP EM.

Installation FTP

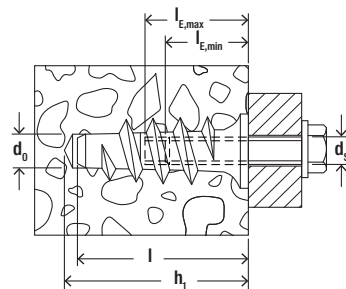
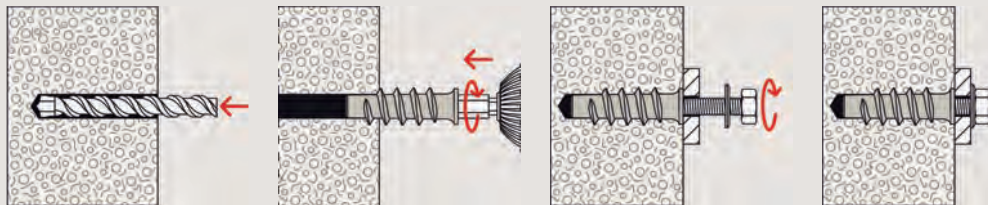

6

Technical data

Turbo aircrete anchor FTP M



FTP M (metal)

Item	Item No.	Drill hole diameter d_0 [mm]	Min. drill hole depth h_1 [mm]	Anchor length l [mm]	Metric screw M	Min. bolt penetration $l_{E,min}$ [mm]	Max. bolt penetration $l_{E,max}$ [mm]	Sales unit [pcs]
FTP M 6	078415 ¹⁾	8 - (10)	60	50	M 6	15	20	25
FTP M 8	078416 ¹⁾	10 - (12)	70	60	M 8	20	25	25
FTP M 10	078417 ¹⁾	12 - (14)	80	70	M 10	25	30	25

¹⁾ Values in brackets for drill hole diameter apply for aerated concrete, compressive strength of 5,0 N/mm² or higher.

Accessories

Setting tool FTP EM



FTP EM for FTP M (metal)

Item	Item No.	Match	Sales unit [pcs]
FTP EM 6	078577	FTP M6	1
FTP EM 8	078578	FTP M8	1
FTP EM 10	078579	FTP M10	1

Loads

Turbo aircrete anchor FTP M

Highest recommended loads¹⁾ for a single anchor in aerated concrete and gypsum blocks.
The given loads are valid for metric screws with the specified thread size.

Type		FTP M 6	FTP M 8	FTP M 10
Thread size	[mm]	M 6	M 8	M 10
Min. edge distance	c_{min} [mm]	100	150	200
Recommended loads in the respective base material F_{rec} ²⁾				
Aerated concrete	ACC 2 ($\geq 2,5 \text{ N/mm}^2$) [kN]	0.30	0.45	0.60
Aerated concrete	ACC 4 ($\geq 5,0 \text{ N/mm}^2$) [kN]	0.50	0.65	0.70
Aerated concrete	ACC 6 ($\geq 7,5 \text{ N/mm}^2$) [kN]	0.70	0.80	0.90
Gypsum block	[kN]	-	0.45	0.65

¹⁾ Required safety factors are considered.

²⁾ Valid for tensile load, shear load and oblique load under any angle.

Brass fixing PA 4

The brass fixing for thin board building materials and solid building materials



6



Furniture fittings



Furniture hinges

Applications

- Handles
- Angle brackets
- Furniture fittings
- Lamps

Advantages

- The short brass fixing PA 4 only requires a very low anchorage depth and is therefore the solution for thin board building materials.
- The special surface structure of the PA 4 prevents the fixing from rotating in the

drill hole. This provides increased installation safety.

- The internal thread allows for the use of standard metric screws and enables the ideal adaptation to suit the intended use.

Building materials

- Wooden board building materials
- Plastic boards
- Concrete
- Solid brick
- Solid sand-lime brick
- Natural stone with dense structure

Functioning

- The PA 4 is suitable for pre-positioned installation.
- Turning in the metric screw causes the front part of the brass fixing to expand, thus securely anchoring it in the substrate.
- Calculating screw length for flush fixing installation: Fixing length + fixture thickness = min. screw length

Installation PA 4

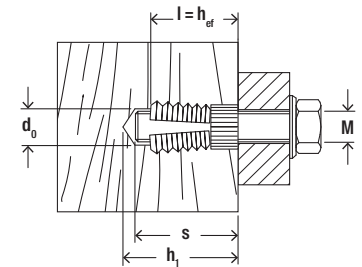
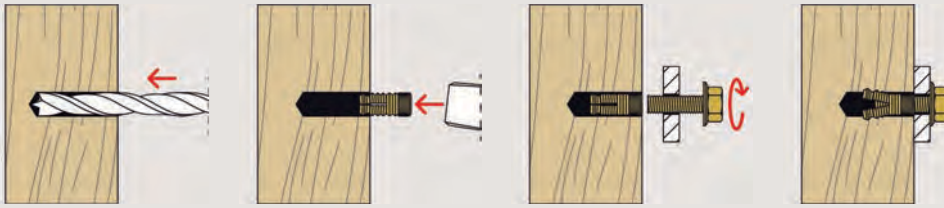

6

Technical data

Brass fixing PA 4



PA4

Item	Item No.	Drill hole diameter d_0 [mm]	Min. drill hole depth h_1 [mm]	Anchor length l [mm]	Thread M	Bolt penetration s [mm]	Effect. anchorage depth h_{ef} [mm]	Sales unit [pcs]
PA 4 M 6/7,5	050484 ¹⁾	8	7,5	7,5	M 6	7,5	7,5	200
PA 4 M 6/10,5	058484 ¹⁾	8	10,5	10,5	M 6	10,5	10,5	100
PA 4 M 6/13,5	059484 ¹⁾	8	13,5	13,5	M 6	13,5	13,5	100
PA 4 M 8/25	050485 ¹⁾	10	25	25	M 8	25	25	50
PA 4 M 10/25	050486 ¹⁾	12	25	25	M 10	25	25	25

¹⁾ Values of drill hole diameter apply for hard building materials. For soft building materials the drill diameter needs to be reduced by 0.5 mm.

Loads

Brass fixing PA 4

Highest recommended loads¹⁾ for a single anchor.
The given loads are valid for metric screws with the specified thread size.

Type		PA 4 M 6/7,5	PA 4 M 6/10,5	PA 4 M 6/13,5	PA 4 M 8/25	PA 4 M 10/25
Thread size	[mm]	M 6	M 6	M 6	M 8	M 10
Recommended loads in the respective base material F_{rec} ²⁾						
Chipboard	[kN]	0.20	0.30	0.40	-	-
Fir wood	[kN]	0.18	0.25	0.38	-	-
Beech wood	[kN]	0.50	0.75	1.00	-	-
Plastic material	[kN]	0.75	1.50	2.00	-	-
Solid brick	Mz 12 [kN]	-	-	0.80	1.95	2.30

¹⁾ Required safety factors are considered.

²⁾ Valid for tensile load, shear load and oblique load under any angle.

Balcony cladding fixing P 9 K

For the rear-ventilated stand-off fastening of balcony cladding to hollow profiles



Balcony cladding

6

Applications

- Balcony cladding
- Fittings
- Electrical switches
- Lamps
- Motion detectors

Advantages

- The wide collar of the P9K plug fixes the balcony cladding to the hollow profile with a spacing. This avoids the formation of rot.
- The expansion within the railing post means that no second drilling on the opposite side of the post is necessary. This allows for a practically invisible fixing of the balcony cladding.
- The material quality of the P9K creates an elastic yet load-bearing connection. This allows for the absorption of thermal stresses, thus increasing the lifespan of the cladding.
- The short expansion element means that the balcony cladding fixing only requires a very small cavity. It is therefore suitable for narrow hollow profiles.

Building materials

- For fixing onto hollow metal profiles

Functioning

- Turning in the screw causes the plug to expand in the hollow profile, thus ensuring a load-bearing connection.
- The wide collar prevents direct contact between the fixture and the hollow profile.

Installation P 9 K

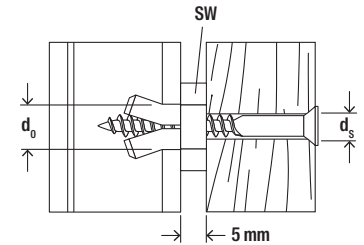
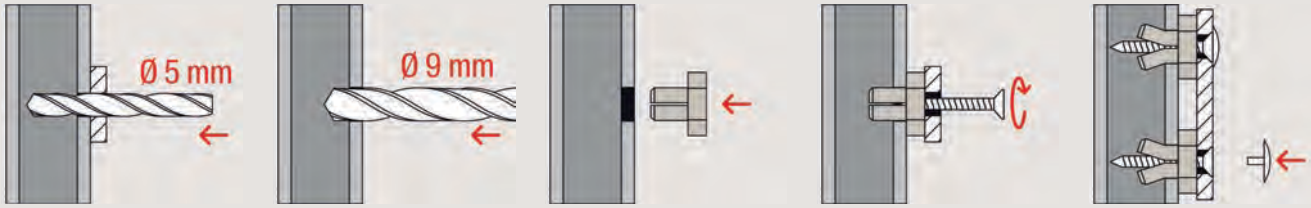

6

Technical data

Balcony cladding fixing P 9 K



P 9 K

Item	Item No.	Drill hole diameter d_0 [mm]	Screw diameter d_s [mm]	Collar height [mm]	Width across nut SW [mm]	Sales unit [pcs]
P 9 K	059395	9	5,0	5	15	50

Loads

Balcony cladding fixing P 9 K

Highest recommended loads¹⁾ for a single anchor.
The given loads are valid for wood screws with the specified diameter.

Type		P 9 K
Screw diameter	[mm]	5
Recommended loads in the respective base material $F_{rec}^{2)}$		
Wall thickness of hollow profile	2 mm	[kN] 0.27
Wall thickness of hollow profile	3 mm	[kN] 0.29
Wall thickness of hollow profile	4 mm	[kN] 0.31

¹⁾ Required safety factors are considered.

²⁾ Valid for tensile load, shear load and oblique load under any angle.

Stair-tread fixing TB / TBB

To fix wooden step treads in concrete and steel sub-structures



6



Stair treads on steel stair stringers



Stair treads on concrete stair stringers

Applications

- Wooden step treads

Advantages

- The elastic shaft geometry allows for the absorption of vibrations, prevents creaking, and thus increases comfort.

- The stair-tread fixing for steel sub-structures (TB) only requires a very small cavity due to the short expansion element. Thus it is suitable even for narrow steel profiles.

Building materials

TB for fixing in:

- Hollow steel profiles

TBB for fixing in:

- Concrete
- Solid building materials

Functioning

- The plastic expansion plugs are suitable for anchoring wooden step treads and wooden boards >30 mm to steel profiles (TB) or in solid building materials (TBB).
- The ideal retention forces are only achieved when using cold wood glue for the fixing in wooden step treads.
- The plastic washers included with the TBB allow you to level out any unevenness in the substrate.

Installation TB

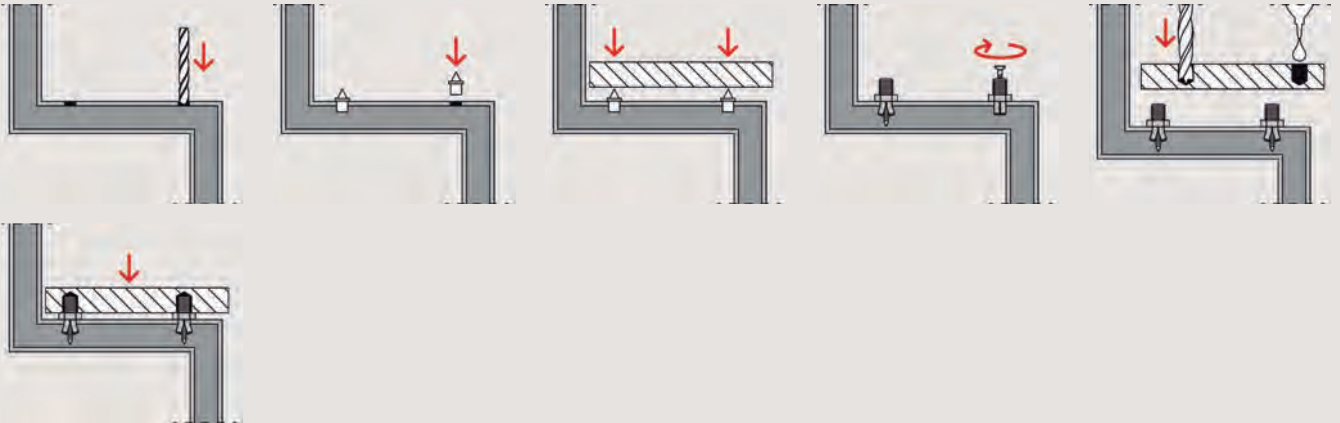

Installation TBB

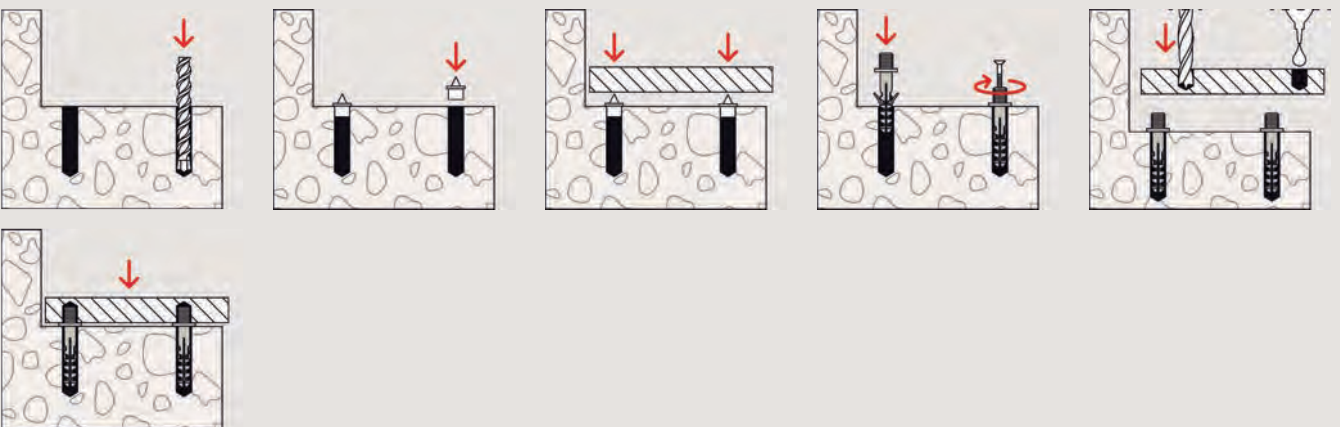

Technical data

Stair-tread fixing TB / TBB



TB for installation on steel staircase stringers

TBB for installation on concrete staircase stringers

TBZ 2 for centre-marking the stair-tread holes

Item	Item No.	Drill hole in stair thread [Ø mm]	Drill hole in steel staircase stringer [Ø mm]	Drill hole in concrete [Ø mm]	Collar height [mm]	Screw d _s x l _s [mm]	Width across nut SW [mm]	Adapted for	Sales unit [pcs]
TB	060580	14 x 25	9	—	5	5 x 40	15	—	50
TBB	060583	14 x 25	—	8 x 55	—	5,5 x 70	—	—	50
TBZ 2	060584	—	—	—	—	—	—	TB and TBB	10

Repair pad FixIt

To repair over-sized or damaged drill holes



6



Repairing damaged drill holes



Repairing damaged drill holes

Applications

- To repair over-sized or damaged drill holes for use with plastic plugs

Advantages

- Using FixIt means that you can avoid having to drill another hole, and makes it possible to reuse a pre-existing drill hole.
- The repair pad FixIt can be used as a single layer or as multiple layers, and thus can be flexibly adapted to suit various drill

hole sizes and shapes.

- The pad, which is covered with a special mortar, hardens after only approx. three minutes in the drill hole. This allows for a fast installation of the fixture.

Building materials

- Concrete
- Cavity floor slabs made from bricks and concrete
- Vertically perforated brick made from lightweight concrete
- Solid sand-lime brick
- Natural stone with dense structure
- Aerated concrete
- Solid brick made from lightweight concrete
- Solid brick

Functioning

- The pad, which is covered with a special mortar, hardens in the drill hole, thus anchoring the plug securely in the damaged or over-sized drill hole.
- Wet the pad with water, wrap it around the plug and push it into the damaged drill hole.
- After about three minutes the special pad will harden and the fixture can then be attached.
- Use several pads for larger tolerances.
- The curing time for the first pad is approx. three minutes. Add an additional minute for each additional pad used.

Installation FixIt

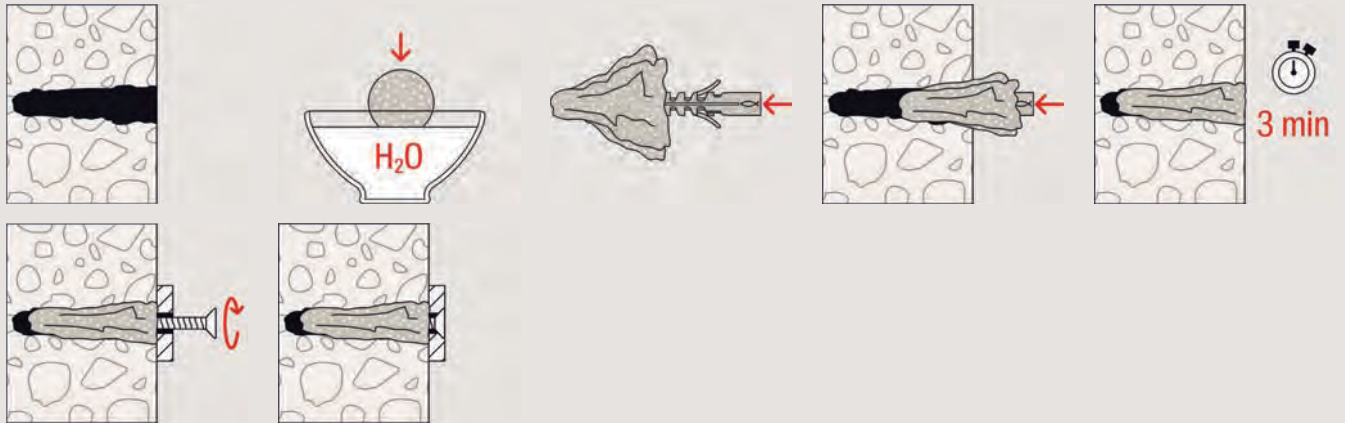

6

Technical data

Repair pad FixIt			
Item	Item No.	Contents	Sales unit [pcs]
FixIt	092507	card with 10 FixIt pads	10

Doorstop TS

The installation-friendly doorstop

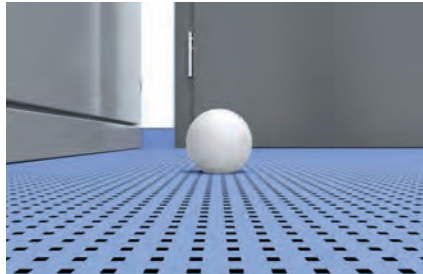

Doorstop

6

Applications

- Doorstop with flexible positioning

Characteristics



Advantages

- The extended plug shaft makes it possible to attach the doorstop directly, thus simplifying installation.
- The invisible fixing ensures visual appeal.
- The TS contains all the components

Building materials

- Concrete
- Floor screed

required for installation and is therefore a convenient complete solution.

- The doorstop is available in a range of colours to suit every floor covering and individual design wishes.

Functioning

- The doorstop TS is suitable for pre-positioned installation.
- When turning in the screw, the plug expands and anchors itself in the building material.
- The plug must be pushed into the drill hole up to the point where the plug shaft thickens.
- It can be removed by removing the doorstop, unscrewing the screw, and pulling out the plug.

Installation TS



Technical data

Doorstop TS



TS

Assortment TS-SORT

Item	Item No.	Drill hole diameter d_0 [mm]	Min. drill hole depth h_1 [mm]	Colour	Contents	Sales unit [pcs]
TS 8 G	060535	8	50	grey	—	10
TS 8 W	060536	8	50	white	—	10
TS 8 S	060539	8	50	black	—	10
TS 8 BR	060540	8	50	brown	—	10
TS 8 BG	060551	8	50	beige	—	10
TS-SORT	060521	8	50	assortment	5 x grey, white, beige, black brown	1





7



7

Cavity fixings

Nylon toggle DUOTEC	422	
Metal cavity fixing HM	426	
Spring-toggle KD, KDH, KM	430	
Board fixing PD	434	
Plasterboard fixing DUOBLADE	436	
Plasterboard fixing GK	439	
Plasterboard fixing GK GREEN	442	
Plasterboard fixing metal GKM	445	

Nylon toggle DuoTec

Easy to install nylon toggle for high loads in all panel building materials



Kitchen hanging cabinets



Shelves

7

Applications

- Kitchen hanging cabinets
- Living room cabinets
- Shelves
- Wardrobes
- Handrails
- Pictures
- Mirrors
- Lamps
- Heavy hanging baskets

Advantages

- Flexible screw mount allows for the use of screws and hooks with different thread shapes.
- Glass fibre-reinforced plastics and a metal skeleton insert (fischer DuoTec 12) allow the toggle to handle heavy tensile and transverse loads in all panel building materials.
- Soft grey nylon contact surface distributes the load over the panel surface, thereby minimising weakening of the

- supporting building material.
- Standard drill hole diameters and short tilting element for easy installation in narrow cavities, including cavities with insulation.
- White flush sleeve with snap function allows the plug to be pre-installed quickly and securely in the drill hole.
- With scale on the grip strap (fischer DuoTec 12) for determining the required screw length (scale value + 20 mm).

Certificates



Building materials

Suitable for:

- Gypsum plasterboard
- Gypsum fibreboard
- Wooden panels, such as OSB boards, chipboard, MDF sheets
- Steel plates
- Plastic boards
- Hollow blocks made from concrete

Also functioning in:

- Solid materials, such as concrete and wood

Functioning

- The fischer DuoTec is designed for pre-positioned installation.
- Simple installation with a standard diameter 10 or 12 mm drill bit.
- The short toggle element makes it suitable for narrow and even with mineral wool insulated cavities. Note the length of the toggle element!
- Functions like an expansion plug in solid building materials such as concrete or wood. Note, not with metric screws!
- Flexible screw insert allows for the use of wood, chipboard and metric screws and hooks.

Installation in board materials

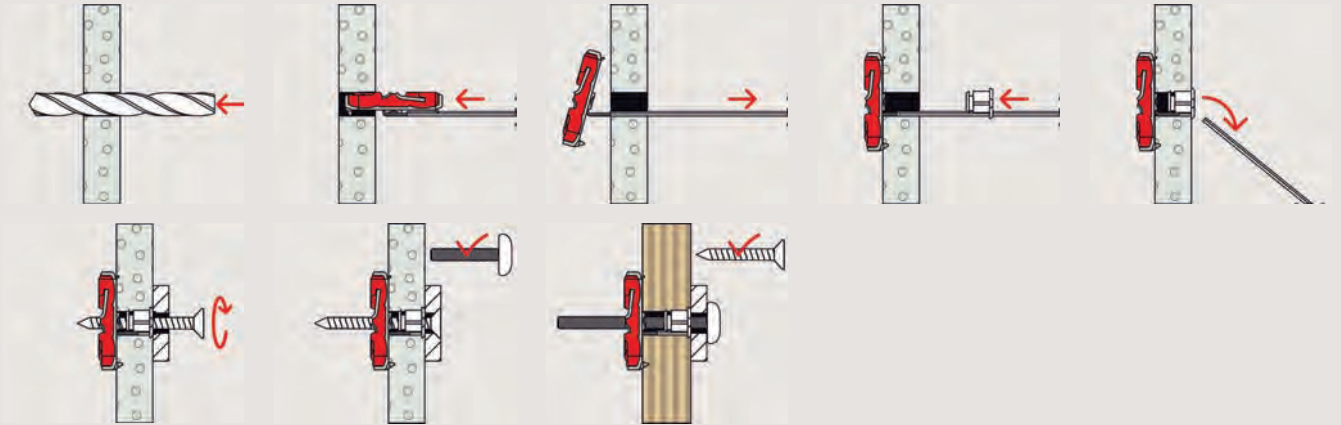

Installation in cavities

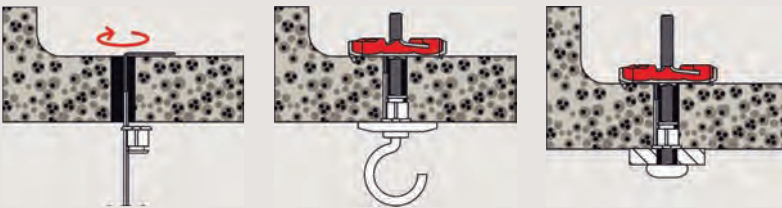

7

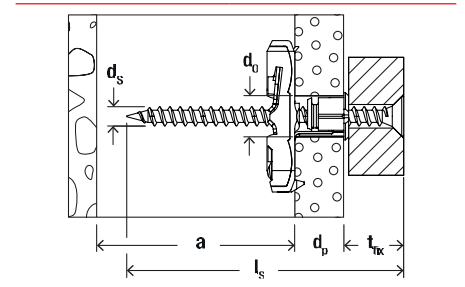

Technical data in board material

Nylon toggle fischer DuoTec



Item	Item No.	Drill hole diameter d_0 [mm]	Min. panel thickness d_p [mm]	Max. panel thickness d_p [mm]	Min. cavity depth a [mm]	Screw diameter d_s [mm]	Screw length l_s [mm]	Sales unit [pcs]
fischer DuoTec 10 S	537259 ¹⁾	10	12	55	40	5,0	60	25
fischer DuoTec 10	537258	10	12	55	40	—	$\geq d_p + t_{fix} + 20$	50
fischer DuoTec 10 S PH	539025 ²⁾	10	12	55	40	—	60	25
fischer DuoTec 12	542796	12	12	55	50	—	$\geq d_p + t_{fix} + 20$	10
fischer DuoTec 12 RH	542798 ⁴⁾	12	12	55	50	5,5	70	10
fischer DuoTec 12 S PH M	542797 ³⁾	12	12	55	50	—	70	10

1) fischer DuoTec S - with chipboard screw countersunk head

2) fischer DuoTec S PH - with chipboard screw panhead

3) fischer DuoTec S PH M - with machine screw panhead

4) fischer DuoTec RH - with screw with round hook

Installation for hits in solid building materials

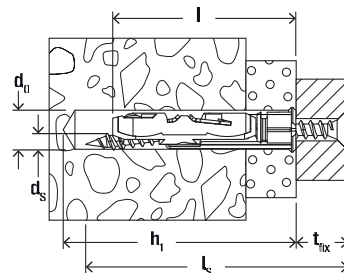
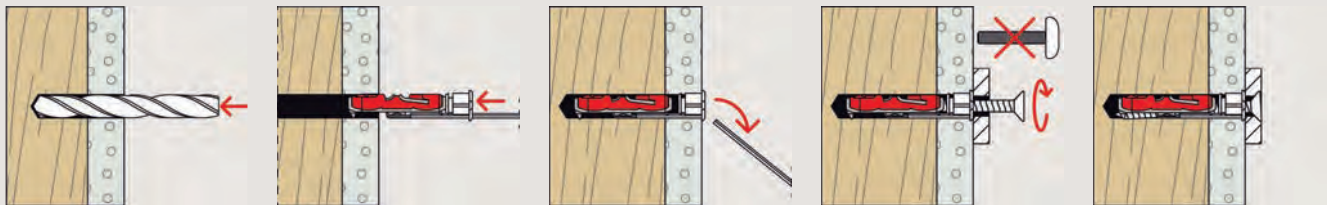

7

Technical data in solid materials

Nylon toggle fischer DuoTec



fischer DuoTec 10

fischer DuoTec 12

fischer DuoTec S PH

Item	Item No.	Drill hole diameter d_0 [mm]	Min. drill hole depth h_1 [mm]	Screw diameter [mm]	Min. screw length l_s [mm]	Anchor length l [mm]	Max. fixture thickness t_{fix} [mm]	Sales unit [pcs]
fischer DuoTec 10 S	537259 ¹⁾	10	65	5,0	60	50	27	25
fischer DuoTec 10	537258	10	$l_s - t_{fix} + 10$	4,5 - 5,0	$t_{fix} + 55$	50	$l_s - 55$	50
fischer DuoTec 10 S PH	539025 ²⁾	10	65	5,0	60	50	27	25
fischer DuoTec 12	542796	12	$l_s - t_{fix} + 10$	5,0 - 6,0	$t_{fix} + 65$	60	$l_s - 65$	10
fischer DuoTec 12 RH	542798 ³⁾	12	75	5,5	55	60	—	10

1) fischer DuoTec S - with chipboard screw countersunk head

2) fischer DuoTec S PH - with chipboard screw panhead

3) fischer DuoTec RH - with screw with round hook

Loads

Nylon toggle DuoTec									
Recommended loads ^{1) 2)} for a single anchor.									
Type		DuoTec 10				DuoTec 12			
		Chipboard screws		Metrical screw	fischer Hook	Chipboard screws		Metrical screw	fischer Hook
Screw diameter	[mm]	4.5	5.0	5.0	5.0	5.0	6.0	6.0	5.5
Recommended loads in the respective base material $F_{rec}^{3)}$ for a span in the construction $b = 625$ mm									
Gypsum plasterboard	9.5 mm	[kN]	0.17	0.17	0.17	0.17	0.17	0.17	0.17
Gypsum plasterboard	12.5 mm	[kN]	0.20	0.20	0.20	0.20	0.20	0.20	0.20
Gypsum plasterboard	2 x 12.5 mm	[kN]	0.43	0.43	0.43	0.30 ⁴⁾	0.43	0.43	0.43
Gypsum fibreboard	12.5 mm	[kN]	0.51	0.51	0.51	0.30 ⁴⁾	0.51	0.51	0.50 ⁴⁾
Chipboard	16 mm	[kN]	0.71	0.71	0.71	0.30 ⁴⁾	0.75	0.80	0.50 ⁴⁾
OSB board	18 mm	[kN]	0.75	0.75	0.75	0.30 ⁴⁾	0.75	1.30	0.50 ⁴⁾
Recommended loads in the respective base material $F_{rec}^{3)}$ for a span in the construction $b = 120$ mm									
Gypsum plasterboard	9.5 mm	[kN]	0.20	0.20	0.20	0.20	0.20	0.20	0.20
Gypsum plasterboard	12.5 mm	[kN]	0.36	0.36	0.36	0.30 ⁴⁾	0.36	0.36	0.20
Gypsum plasterboard	2 x 12.5 mm	[kN]	0.59	0.59	0.59	0.30 ⁴⁾	0.70	0.80	0.50 ⁴⁾
Gypsum fibreboard	12.5 mm	[kN]	0.75	0.75	0.75	0.30 ⁴⁾	0.80	1.10	0.50 ⁴⁾
Chipboard	16 mm	[kN]	0.75	0.75	0.75	0.30 ⁴⁾	0.80	1.40	0.50 ⁴⁾
OSB board	18 mm	[kN]	0.75	0.75	0.75	0.30 ⁴⁾	0.80	1.50	0.50 ⁴⁾
Recommended loads in solid building materials $F_{rec}^{3)}$									
Concrete	$\geq C20/25$	[kN]	0.45	0.75	-	0.30 ⁴⁾	0.40	0.75	0.30
Wood		[kN]	0.30	0.75	-	0.30 ⁴⁾	0.20	0.65	0.30
Recommended loads in the respective base material $F_{rec}^{3)}$									
Hollow block of lightweight aggregate concrete 'Sepa Parpaing'	$f_b \geq 8$ N/mm ²	[kN]	-	-	-	-	0.65	1.00	0.50 ⁴⁾
Pre-stressed hollow-core concrete slabs		[kN]	-	-	-	-	1.00	1.40	0.50 ⁴⁾
Lightweight concrete hollow block Hbl acc. to EN 771-3	$f_b \geq 2$ N/mm ²	[kN]	-	-	-	-	0.90	1.00	0.50 ⁴⁾

¹⁾ Required safety factors are considered.

²⁾ The recommended loads are reference values and depending to the building material and the workmanship. The values are only valid for the given screw diameter.

³⁾ Valid for tensile load, shear load and oblique load under any angle.

⁴⁾ Bending of the hook is decisive. Only for tension load.

Metal cavity fixing HM

The versatile metal cavity fixing with metric screws



Curtain rails



Shelves

7

Applications

- Pictures
- Lighting
- Light shelves
- Towel rails
- Mirror cabinets
- Curtain rails
- Sub-structures

Advantages

- Due to the extensive range, the HM is suitable for board building materials with a thickness of 3-50 mm and thus suitable for a number of different applications.
- The metric internal thread allows the attachment to be removed and refitted several times, thus offering the best possible flexibility.

- The HM's expanding arms ensure a large supporting surface, thus allowing a high load-bearing capacity.
- The claws around the edge of the fixing penetrate the board building material, preventing the fixing from rotating, thus ensuring a secure installation.

Building materials

- Gypsum plasterboard and gypsum fibreboards
- Cavity floor slabs
- Light building boards made of wood wool
- Chipboard
- Plywood boards

Functioning

- The metal cavity fixing HM is suitable for pre-positioned installation.
- The fixing should be selected based on the thickness of the board building material, to allow the very best expansion in the cavity.
- During installation, the expanding arms swing open and press onto the reverse side of the board.
- The HM can be installed using installation pliers. If using a battery operated screwdriver or screwdriver for installation, the pre-assembled screws must be removed first. When screwing in and expanding the fixing, the attachment, or a max. 6 mm plate, needs to be used as a turning stop.

Installation HM

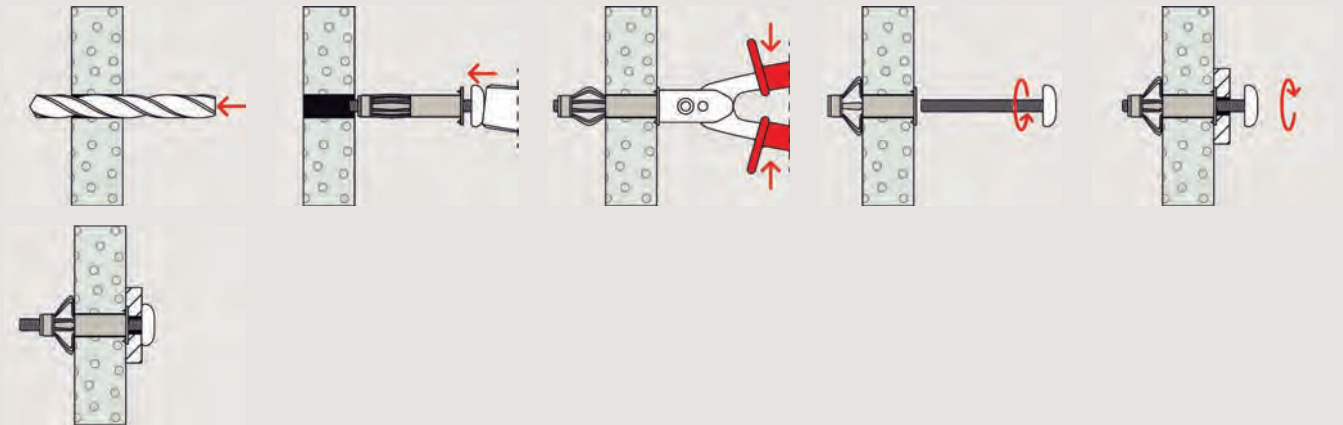

Installation HM

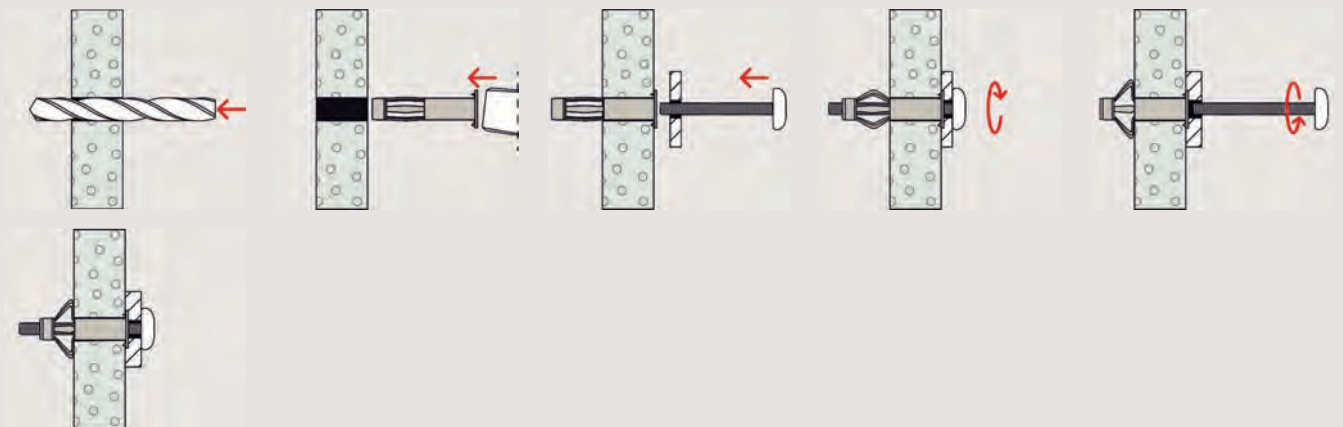

7

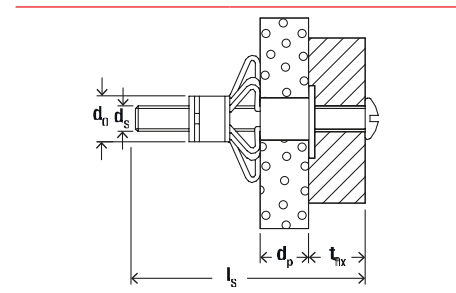

Technical data in board material

Metal cavity fixing HM



HM-S with metric screw

HM-SS with hexagon headed screw

HM-H with angle hook

Item	Item No.	Drill hole diameter d_0 [mm]	Min. drill hole depth h_1 [mm]	Anchor length l [mm]	Screw $d_s \times l_s$ [mm]	Panel thickness d_p [mm]	Fixture thickness t_{fix} [mm]	Drive	Sales unit [pcs]
HM 4 x 32 S	519769	8	40	32	M 4 x 40	3 - 13	≤ 15 - 25	PH2	50
HM 4 x 45 S	519770	8	52	45	M 4 x 52	16 - 23	≤ 12 - 21	PH2	50
HM 4 x 60 S	519771	8	65	60	M 4 x 65	31 - 40	≤ 12 - 21	PH2	50

1) with hexagon headed screw, assembly only by using the professional installation tool HM Z 1

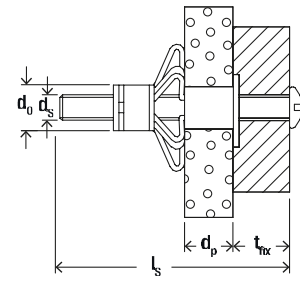

Technical data in board material

Metal cavity fixing HM



HM-S with metric screw

HM-SS with hexagon headed screw

HM-H with angle hook

Item	Item No.	Drill hole diameter d_0 [mm]	Min. drill hole depth h_1 [mm]	Anchor length l [mm]	Screw $d_s \times l_s$ [mm]	Panel thickness d_p [mm]	Fixture thickness t_{fix} [mm]	Drive	Sales unit [pcs]
HM 5 x 37 S	519772	10	45	37	M 5 x 45	6 - 15	≤ 8 - 17	PH2	50
HM 5 x 52 S	519774	10	58	52	M 5 x 58	7 - 21	≤ 10 - 24	PH2	50
HM 5 x 65 S	519775	10	71	65	M 5 x 71	20 - 34	≤ 12 - 26	PH2	50
HM 6 x 37 S	519777	12	45	37	M 6 x 45	6 - 15	≤ 12 - 21	PH3	50
HM 6 x 52 S	519778	12	58	52	M 6 x 58	7 - 21	≤ 14 - 28	PH3	50
HM 6 x 65 S	519782	12	71	65	M 6 x 71	17 - 34	≤ 13 - 30	PH3	50
HM 6 x 80 S	519779	12	88	80	M 6 x 88	32 - 50	≤ 16 - 34	PH3	50
HM 8 x 54 SS	519783 ¹⁾	12	60	54	M 8 x 60	7 - 21	≤ 16 - 30	SW13	50
HM 4 x 32 H	519780	8	45	32	—	3 - 13	—	—	50
HM 5 x 65 H	519781	10	71	65	—	20 - 34	—	—	50

¹⁾ with hexagon headed screw, assembly only by using the professional installation tool HM Z 1

Accessories

Installation pliers HMZ



HM Z 1 - the professional installation tool

HM Z 2 - the DIY installation tool

HM Z 3

Item	Item No.	Adapted for	Sales unit [pcs]
HM Z 1	062320	HM 4 - HM 8	1
HM Z 2	062321	HM 4 - HM 6	1
HM Z 3	539723	HM 4 - HM 6	1

Loads

Metal cavity fixing HM

Recommended loads¹⁾ for a single anchor.

Type			HM 4 x 32 S	HM 4 x 46 S	HM 5 x 37 S	HM 5 x 52 S	HM 5 x 65 S	HM 6 x 37 S	HM 6 x 52 S	HM 6 x 65 S	HM 8 x 55 SS
Thread size			M 4	M 4	M 5	M 5	M 5	M 6	M	M 6	M 8
Recommended loads in the respective base material F_{rec} ²⁾											
Gypsum plasterboard	9.5 mm	[kN]	0.15	0.15	0.15	0.15	-	0.15	-	-	-
Gypsum plasterboard	12.5 mm	[kN]	0.20	0.20	0.20	0.20	-	0.20	0.20	-	0.20
Gypsum plasterboard	19 mm (2 x 9.5 mm)	[kN]	-	-	-	0.25	-	-	0.25	-	0.25
Gypsum plasterboard	25 mm (2 x 12.5 mm)	[kN]	-	-	-	-	0.30	-	-	0.30	-
Chipboard	10 mm	[kN]	0.25	0.25	0.25	0.25	-	0.25	0.25	-	0.25
Chipboard	13 mm	[kN]	0.25	0.25	0.25	0.25	-	0.25	0.25	-	0.25
Chipboard	28 mm	[kN]	-	-	-	-	0.50	-	-	0.50	-
Plywood	4 mm	[kN]	0.10	-	-	-	-	-	-	-	-
Hardboard	3 mm	[kN]	0.10	-	-	-	-	-	-	-	-
Wood wool slab	16 mm	[kN]	-	0.05	-	0.05	-	-	0.05	-	0.05
Wood wool slab	25 mm	[kN]	-	-	-	-	0.05	-	-	0.05	-
Fibre cement board	8 mm	[kN]	0.25	0.25	0.25	0.25	-	0.25	-	-	-
Gypsum fibreboard	10 mm	[kN]	0.25	0.25	0.25	0.25	-	0.25	0.25	-	0.25
Gypsum fibreboard	15 mm	[kN]	-	0.25	0.25	0.25	-	0.25	0.25	-	0.25

¹⁾ Required safety factors are considered.

²⁾ Valid for tensile load, shear load and oblique load under any angle.

Spring-toggle KD, KDH, KM

The cavity fixing for different board thicknesses and large usage lengths



Ceiling lamps



Wash basins

7

Applications

- Pictures
- Lighting
- Light shelves
- Towel rails
- Mirror cabinets
- Light cabinets
- Wash basins and urinals (KM 10)
- Cable and pipe clips

Advantages

- Universal fixing for fastenings in a wide range of drywall and hollow wall materials.
- When the metal crosspiece is pushed through the drill hole, pull it firmly against the inner wall cavity by tugging the plastic pull ring on the outer wall.
- Afterwards cut the plastic legs off and fasten the fixture with e.g. a screw or screw in a hook or an eyebolt according to your demands.
- Suitable for pre-positioned installation.

Building materials

- Gypsum plasterboard and gypsum fibreboards
- Cavity floor slabs made from bricks and concrete
- Chipboard
- Plywood boards

Functioning

- The gravity and spring toggle are suitable for pre-positioned installation.
- When placed in the drill hole, the bearing elements of the gravity and spring toggles independently swing open behind the board.
- The KM 10 is specially suited to fixing wash basins and urinals into installation and cavity walls.
- No special installation tool required. For a fast and convenient installation.

Installation K, KD

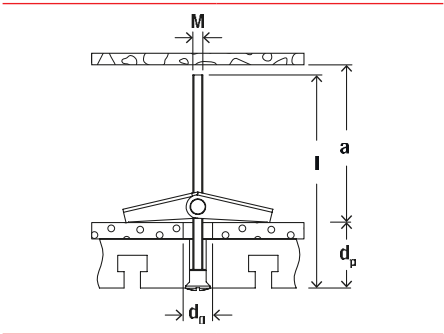
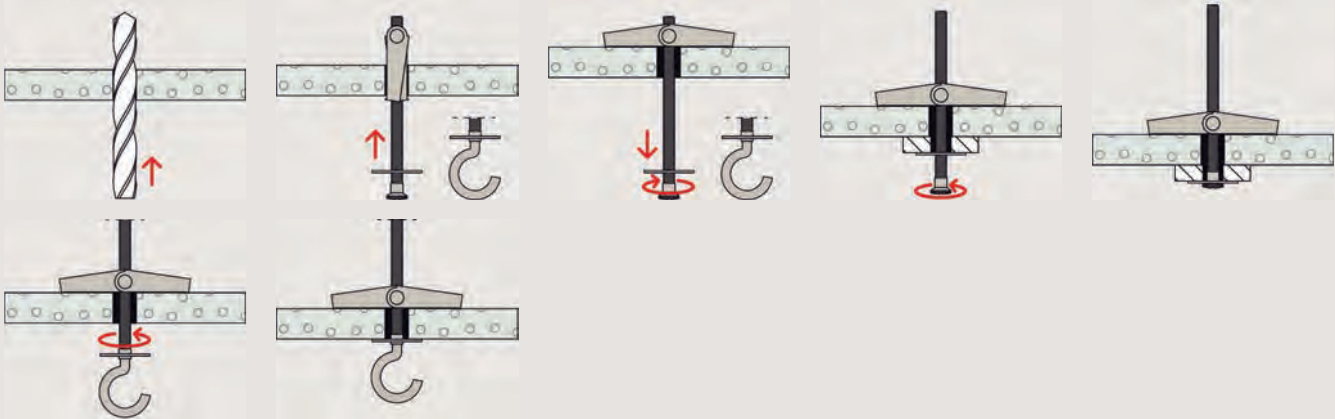

7

Technical data

Spring toggle KD 3+4, KDH 3+4



Item	Item No.	Drill hole diameter d_0 [mm]	Max. panel thickness d_p [mm]	Min. cavity depth a [mm]	Anchor length l [mm]	Thread $\emptyset \times$ length [mm]	Sales unit [pcs]
KD 3	080181	12	65	27	95	M 3 x 90	50
KDH 3	080182	12	51	27	105	M 3 x 80	25
KD 3 B	080192	12	65	27	95	M 3 x 90	10
KD 4	080183	14	69	34	105	M 4 x 100	25
KDH 4	080184	14	35	34	95	M 4 x 70	25
KD 4 B	080193	14	69	34	105	M 4 x 100	10

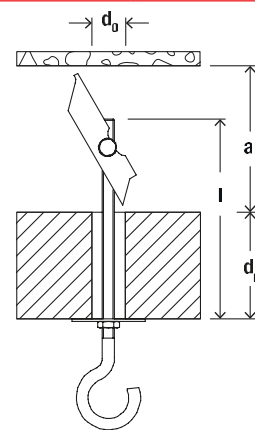

Technical data

Gravity toggle KD 5+6+8, KDH 5+6+8

7

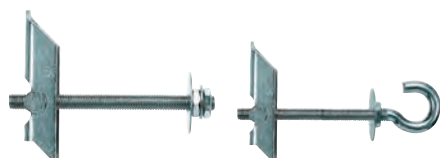

KD 5 + 6 + 8

KDH 5 + 6 + 8

Item	Item No.	Drill hole diameter d_0 [mm]	Max. panel thickness d_p [mm]	Min. cavity depth a [mm]	Anchor length l [mm]	Thread $\varnothing \times$ length [mm]	Sales unit [pcs]
KD 5	080187	16	63	70	100	M 5 x 100	25
KD 6	080185	16	63	70	100	M 6 x 100	25
KD 8	080178	20	55	75	100	M 8 x 100	20
KDH 5	080188	16	60	70	130	M 5 x 90	20
KDH 6	080186	16	60	70	130	M 6 x 100	20
KDH 8	080179	20	55	75	130	M 8 x 100	20

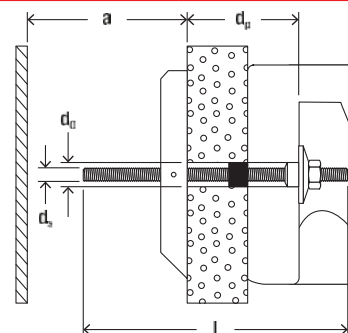

Technical data

Gravity toggle KM 10

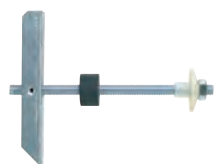

KM 10

Item	Item No.	Drill hole diameter d_0 [mm]	Max. panel thickness d_p [mm]	Min. cavity depth a [mm]	Anchor length l [mm]	Screw $d_s \times l_s$ [mm]	Sales unit [pcs]
KM 10	050326	30	90	140	180	M 10 x 180	25

Loads

Toggle fixing KD

Recommended loads¹⁾ for a single anchor.

Type			KD 3	KD 4	KD 5	KD 6	KD 8
Thread size			M 3	M 4	M 5	M 6	M 8
Recommended loads in the respective base material F_{rec} ²⁾							
Gypsum plasterboard	12.5 mm	[kN]	0.15	0.15	0.15	0.15	0.18
OSB board	≥ 15 mm	[kN]	0.34	0.58	0.85	0.85	0.89

¹⁾ Required safety factors are considered.

²⁾ Valid for axial tensile load.

³⁾ Bending of the hook is decisive. Only for tension load.

Loads

Toggle fixing KDH

Recommended loads¹⁾ for a single anchor.

Type			KDH 3	KDH 4	KDH 5	KDH 6	KDH 8
Thread size			M 3	M 4	M 5	M 6	M 8
Recommended loads in the respective base material F_{rec} ²⁾							
Gypsum plasterboard	12.5 mm	[kN]	0.07 ³⁾	0.13 ³⁾	0.15	0.15	0.18
OSB board	≥ 15 mm	[kN]	0.07 ³⁾	0.13 ³⁾	0.30 ³⁾	0.45 ³⁾	0.89

¹⁾ Required safety factors are considered.

²⁾ Valid for axial tensile load.

³⁾ Bending of the hook is decisive. Only for tension load.

Loads

Toggle fixing KM 10 and K 54

Mean ultimate loads.

Type			KM 10	K 54
Screw diameter			M 10	4 mm
Mean ultimate loads F_u ¹⁾²⁾³⁾		[kN]	13.0	0.8

¹⁾ Upon these failure loads an appropriate safety factor has to be considered.

²⁾ Valid for tensile load, shear load and oblique load under any angle.

³⁾ If the failure of the base material is not possible.

Board fixing PD

The expansion plug for fixings in gypsum plasterboard, gypsum fibreboard and wooden panels



Towel rails



Small shelves

7 Applications

- Pictures
- Lighting
- Light shelves
- Towel rails
- Mirror cabinets
- Curtain rails

Advantages

- The operating principle of the fixing allows for use in various board thicknesses, including in low cavity depths. This provides great flexibility.
- The special fixing geometry with a nylon cone ensures a high tightening torque that can be identified immediately. This offers a high level of installation safety.

- The longitudinal ribs prevent the fixing from rotating in the drill hole, thus allowing for a reliable installation.
- The board fixing PD can be used with the most wide-ranging screws, hooks and eye screws. This allows for a broad range of applications.

Certificates



Building materials

- Gypsum plasterboard and gypsum fibreboards
- Wooden boards
- MDF boards
- Multiplex boards
- OSB boards
- Plywood boards
- Chipboard
- Wood core plywood boards

Functioning

- The board fixing PD is suitable for pre-positioned installation.
- Use rotary drilling to create the drill hole.
- When the screw is tightened, the plastic cone is pulled into the sleeve and expands the fixing.
- Use full-thread screws, or alternatively, the part of the screw without thread may not be longer than the thickness of the item being attached.
- Do not use screws with double-start threads.

Installation PD

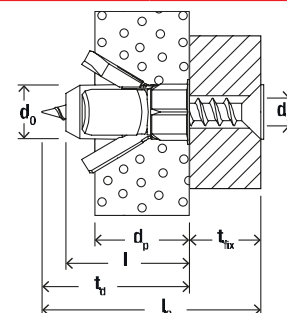
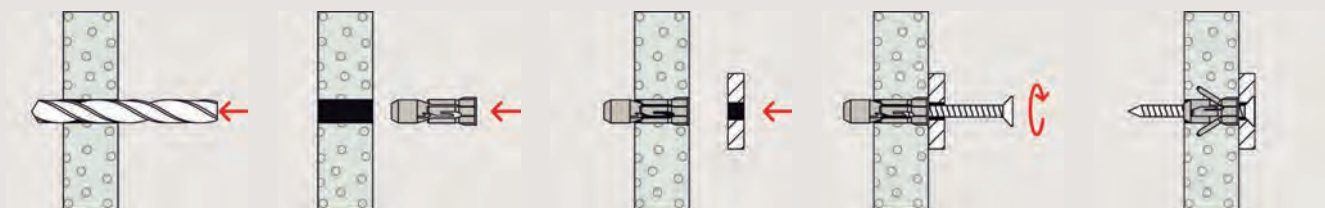

7

Technical data in board material

Board fixing PD



PD

PD S with chipboard screw

Item	Item No.	Drill hole diameter d_0 [mm]	Min. drill hole depth h_1 [mm]	Min. panel thickness d_p [mm]	Anchor length l [mm]	Chipboard screw $d_s / d_s \times l_s$ [mm]	Max. fixture thickness t_{fix} [mm]	Sales unit [pcs]
PD 8	024771	8	31	6	29	4	—	100
PD 10	015935	10	30	7	28	5	—	100
PD 12	015937	12	29	9	27	6	—	50
PD 8 S	024772 ¹⁾	8	31	6	29	4 x 40	11	50
PD 10 S	015936 ¹⁾	10	30	7	28	5 x 40	12	50
PD 12 S	015938 ¹⁾	12	29	9	27	6 x 50	22	25

1) PD-S with chipboard screw.

Loads

Board fixing PD

Recommended loads¹⁾ for a single anchor.

Type		PD 8	PD 10	PD 12
Chipboard screw diameter	[mm]	4.0	5.0	6.0
Recommended loads in the respective base material F_{rec} ²⁾				
Gypsum plasterboard	9.5 mm	[kN] 0.10	0.10	0.10
Gypsum plasterboard	12.5 mm	[kN] 0.10	0.10	0.15
Gypsum plasterboard	2 x 12.5 mm	[kN] 0.15	0.15	0.15
Gypsum fibreboard	12.5 mm	[kN] 0.20	0.25	0.30
Plywood		[kN] 0.15	0.40	0.80
Chipboard	16 mm	[kN] 0.25	0.25	0.25

¹⁾ Required safety factors are considered. The given loads are valid for chipboard screws with the specified diameters.²⁾ Valid for tensile load, shear load and oblique load under any angle.

Plasterboard fixing DuoBlade

The self-drilling plasterboard plug for fast and easy installation



Smoke detectors



Mirrors

7

Applications

- Smoke detectors
- Mirrors
- Curtain rods
- Blinds
- Lamps
- Pictures

Advantages

- An innovative product of the fischer DuoLine with intelligent combinations for more power and more intelligence.
- The self-drilling fischer DUOBLADE allows fast and easy installation in gypsum plasterboard and gypsum fibreboard.
- The black metal tip guarantees simple and safe installation.
- High torque when anchor is installed for the feelgood-factor and an optimum feeling when setting.
- PZ 2 drive - same drive for plug and screw.

Certificates



Building materials

- Gypsum plasterboard, single and double-planked
- Gypsum fibreboard
- Lightweight cement boards

Functioning

- The fischer DuoBlade is suitable for pre-positioned installation.
- The metal tip for better heat-resistant and cutting characteristics. Especially in double-layered plasterboard.
- The fischer DuoBlade can be used with wood, metal and chipboard screws of Ø4.0 to Ø5.0 mm.
- In gypsum fibreboard, pre-drilling with a drill Ø 8mm is recommended.

Installation DuoBlade

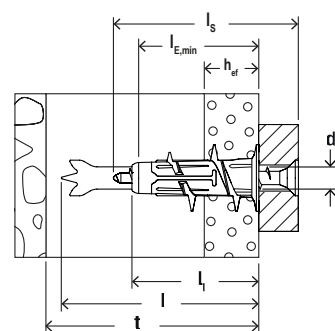
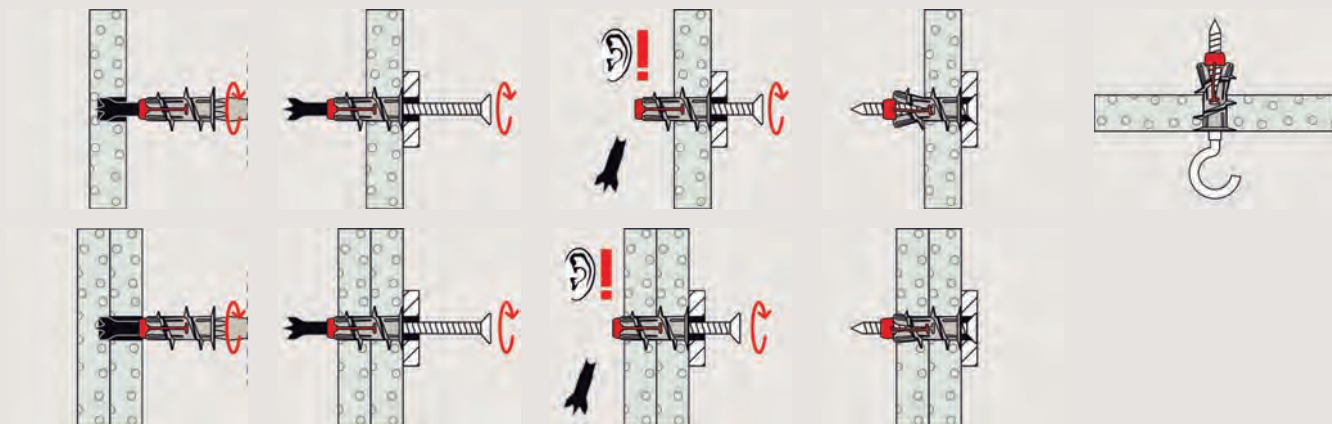

7

Technical data in board material

Plasterboard fixing DuoBlade



DuoBlade

Item	Item No.	Min. thickness to first supporting layer t [mm]	Anchor length l [mm]	Anchor length without drill tip l ₁ [mm]	Anchorage depth h _{ef} [mm]	Min. bolt penetration l _{E,min} [mm]	Wood and chipboard screws d _S / d _S x l _S [mm]	Drive	Sales unit [pcs]
DuoBlade	545675	50	44	29	9,5 - 25	28	4 - 5	PZ2	50
DuoBlade S	545676 ¹⁾	50	44	29	9,5 - 25	28	4,5 x 40	PZ2	25
DuoBlade K NV	545683	50	44	29	9,5 - 25	28	4 - 5	—	10
DuoBlade S K NV	545684 ¹⁾	50	44	29	9,5 - 25	28	4,0 x 46	PZ2	6
DuoBlade RH K NV	545686 ³⁾	50	44	29	9,5 - 25	28	4,5 x 40	—	6
DuoBlade WH K NV	545685 ²⁾	50	44	29	9,5 - 25	28	4,2 x 40	—	6

1) With chipboard screw countersunk head.

2) With screw with angle hook.

3) With screw with round hook.

Loads

Plasterboard fixing DuoBlade			
Recommended loads ¹⁾ for a single anchor.			
Type			DuoBlade
Chipboard screw diameter		[mm]	4.0 - 5.0
Recommended loads in the respective base material F_{rec} ²⁾			
Gypsum plasterboard	9.5 mm	[kN]	0.08
Gypsum plasterboard	12.5 mm	[kN]	0.10
Gypsum plasterboard (e.g. Knauf Diamant board or Rigips Die Harte)	12.5 mm	[kN]	0.18
Gypsum plasterboard	2 x 12.5 mm	[kN]	0.20
Lightweight cement board	12.5 mm	[kN]	0.08
Gypsum fibreboard	12.5 mm	[kN]	0.34

¹⁾ Required safety factors are considered. The given loads are valid for chipboard screws with the specified diameters.

²⁾ Valid for tensile load, shear load and oblique load under any angle.

Plasterboard fixing GK

The fastest installation in gypsum plasterboard



Wall lamps



Pictures

Applications

- Pictures
- Lighting
- Electrical installations
- Fitting accessories
- Series installations

Certificates



Advantages

- The included setting tool combines the drilling and fixing setting functions. It thus allows for a fast and simple installation.
- The sharp, self-tapping thread of the GK enables a secure, positive fit fixing. This achieves a high load-bearing capacity.
- The short fixing length means that only a small amount of space is required behind the board. As a result, the GK can also be used in the case of unknown board

Building materials

- Gypsum plasterboard, single and double-planked

thickness and cavity depth.

- The cross-drive recess in the head of the fixing means that the GK can also be screwed out like a screw without a setting tool.
- The GK can be used with the most wide-ranging screws, hooks and eye screws. This allows for a broad range of applications.

Functioning

- The gypsum plasterboard fixing GK is suitable for pre-positioned installation.
- The GK is screwed flush into the gypsum plasterboard using the setting tool provided. Overtightening the fixing should be avoided. Therefore, the installation torque should be limited when using a battery operated screwdriver.
- Adapted for wood, self-tapping and chip-board screws of 4.0 to 5.0 mm diameter.
- For board thicknesses greater than 15 mm, drill a hole first by using the setting tool.
- Not suitable for gypsum fibreboard and tiled plasterboard.

Installation GK

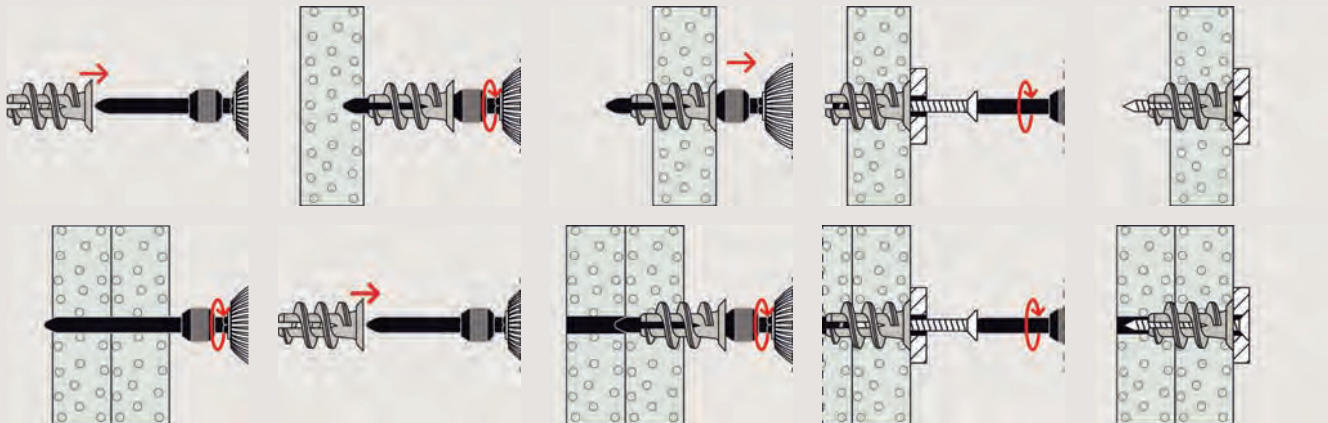

7

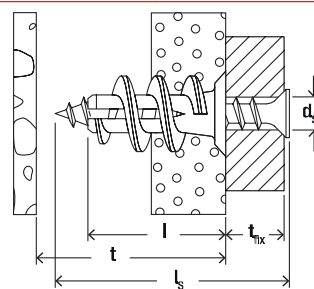

Technical data in board material

Plasterboard fixing GK



GK

GK S

Item	Item No.	Anchor length l [mm]	Min. thickness to first supporting layer t [mm]	Max. fixture thick- ness t _{fix} [mm]	Screw d _s x l _s [mm]	Drive	Sales unit [pcs]
GK	052389 ¹⁾²⁾	22	25	—	4,0 - 5,0 x Ls	—	100
GK S	052390 ¹⁾³⁾	22	25	13	4,5 x 35	PZ2	50

1) Including installation tool GKW.

2) Min. screw length = length of plug 22 mm + thickness of building component.

3) Supplied with plasterboard screw.

Accessories

Plasterboard fixing GK



GKW

Profi-Box GK

Item	Item No.	Contents	Sales unit [pcs]
GKW	052393	—	10
Profi-Box GK	518528	50 Plasterboard fixings GK, 1 Installation tool, 38 Chipboard screws 4,5 x 35, 6 Angle hooks 4,2 x 40, 6 Round hooks 4 x 46	1

7

Loads

Plasterboard fixing GK

Recommended loads¹⁾ for a single anchor.

Type		GK
Chipboard screw diameter	[mm]	4.0 - 5.0
Recommended loads in the respective base material F_{rec} ²⁾		
Gypsum plasterboard	9,5 mm	[kN] 0.07
Gypsum plasterboard	12,5 mm	[kN] 0.08
Gypsum plasterboard	2 x 12,5 mm	[kN] 0.11

¹⁾ Required safety factors are considered. The given loads are valid for chipboard screws with the specified diameters.

²⁾ Valid for tensile load, shear load and oblique load under any angle.

Plasterboard fixing GK Green

The fastest installation in gypsum plasterboard



Wall lamps



Pictures

7

Applications

- Pictures
- Lighting
- Electrical installations
- Fitting accessories
- Series installations

Advantages

- Produced with at least 50% renewable raw materials and therefore particularly environmentally friendly.
- Just as effective, secure and durable as regular GK plugs.
- The included setting tool combine the functions of drilling and setting fixings for direct and easy installation.
- Sharp, self-tapping thread for a positive-fit connection with a high load-bearing capacity.
- The cross-drive recess in the head of the fixing means that the GK Green can also easily be screwed out like a screw.
- The GK Green can be used with various screws, hooks and eye screws, making it very versatile in its applications.

Certificates



Building materials

- Gypsum plasterboard, single and double-planked

Functioning

- The gypsum plasterboard fixing GK Green is suitable for pre-positioned installation.
- The GK Green is screwed flush into the gypsum plasterboard using the setting tool provided. Avoid manual and machine-aided overtightening.
- For board thicknesses greater than 15 mm, drill a hole first by using the setting tool.
- Adapted for wood, sheet metal and chipboard screws with a diameter of 4.0 to 5.0 mm.
- Not suitable for gypsum fibreboard and tiled plasterboard.

Installation GK Green

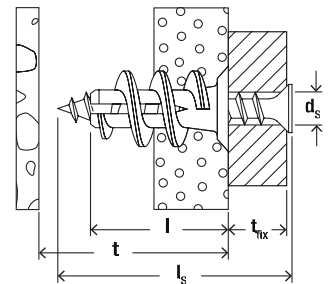
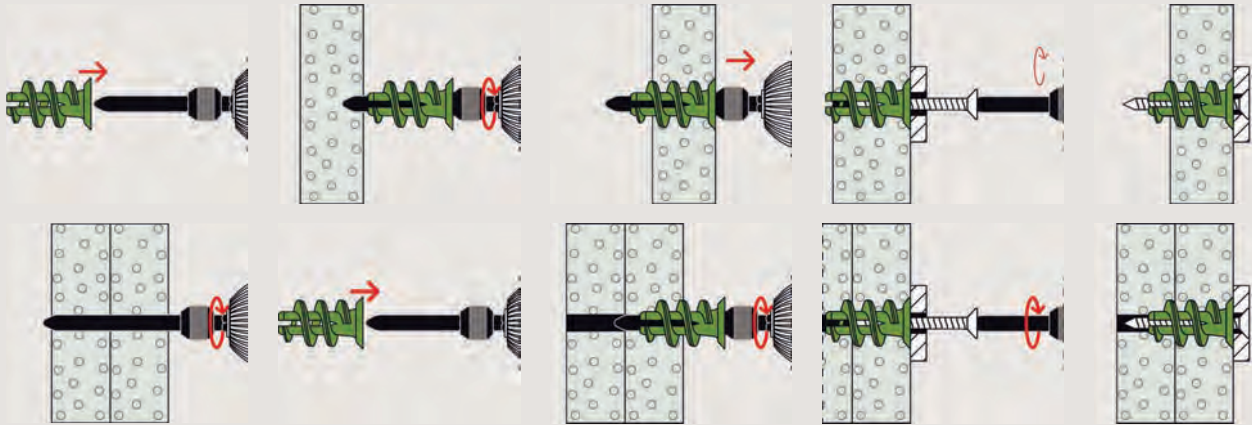

7

Technical data

Plasterboard fixing GK Green



GK Green

GK Green S

Item	Item No.	Anchor length l [mm]	Min. thickness to first supporting layer t [mm]	Max. fixture thick- ness t _{fix} [mm]	Screw d _s x l _s [mm]	Drive	Sales unit [pcs]
GK Green	524868 ¹⁾²⁾	22	25	—	4,0 - 5,0 x Ls	—	90
GK Green S	524869 ¹⁾³⁾	22	25	13	4,5 x 35	PZ2	45

1) Including installation tool GWK.

2) Min. screw length = length of plug 22 mm + thickness of building component.

3) Supplied with plasterboard screw.

Accessories

Installation tool GWK



GWK

Item	Item No.	Sales unit [pcs]
GWK	052393	10

Loads

Plasterboard fixing GK Green			
Recommended loads ¹⁾ for a single anchor.			
Type			GK
Chipboard screw		[mm]	4.0 - 5.0
Recommended loads in the respective base material F_{rec} ²⁾			
Gypsum plasterboard	9.5 mm	[kN]	0.07
Gypsum plasterboard	12.5 mm	[kN]	0.08
Gypsum plasterboard	2 x 12.5 mm	[kN]	0.11

¹⁾ Required safety factors are considered. The given loads are valid for chipboard screws with the specified diameters.

²⁾ Valid for tensile load, shear load and oblique load under any angle.

Plasterboard fixing metal GKM

The self-tapping metal fixing for gypsum plasterboard and gypsum fibreboard



Wall lamps



Speaker cabinets

Applications

- Pictures
- Lighting
- Electrical installations
- Fitting accessories

Advantages

- Due to its material properties, the GKM can be used in gypsum plasterboard and gypsum fibreboard, and can be used with the most wide-ranging screws, hooks and eye screws. This allows for a broad range of applications.
- The sharp, self-tapping thread enables a secure, positive fit fixing. This achieves a high load-bearing capacity.

Building materials

- Gypsum fibreboard
- Gypsum plasterboard

- The cross-drive recess means that a standard screwdriver or bit can be used. No special setting tool is required.
- The short fixing length means that only a small amount of space is required behind the board. As a result, the GKM can also be used in the case of unknown board thickness and cavity depth.

Functioning

- The GKM is suitable for pre-positioned installation.
- The self-tapping metal fixing GKM taps itself into the plasterboard with a positive fit.
- Flush installation in the board building material. Overtightening the fixing should be avoided. Therefore, the installation torque should be limited when using a battery operated screwdriver.
- Adapted for wood, self-tapping and chip-board screws of 4.0 to 5.0 mm diameter.
- Pre-drill with a Ø 8 mm drill bit when using gypsum fibreboard and double-planked gypsum plasterboard.
- Not suitable for tiled plasterboard.

Installation GKM

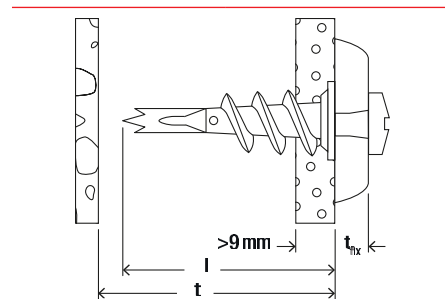
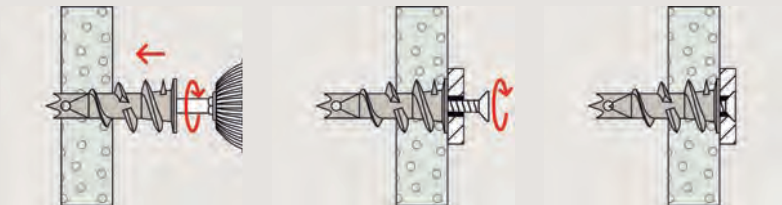

7

Technical data

Plasterboard fixing metal GKM



GKM

Item	Item No.	Anchor length	Min. thickness to first supporting layer	Max. fixture thickness	Screw	Drive	Sales unit
		l [mm]	t [mm]	t _{fix} [mm]			
GKM	024556	31	35	—	4,0 - 5,0 x Ls	—	100
GKM 12	040432 ¹⁾	31	35	12	4,5 x 35	PZ2	100
GKM 27	040434 ¹⁾	31	35	27	4,5 x 50	PZ2	100

¹⁾ Supplied with plasterboard screws countersunk head.

Loads

Plasterboard fixing metal GKM

Recommended loads¹⁾ for a single anchor.

Type		GKM
Chipboard screw diameter	[mm]	4.0 - 5.0
Recommended loads in the respective base material F _{rec} ²⁾		
Gypsum plasterboard	9.5 mm	[kN] 0.07
Gypsum plasterboard	12.5 mm	[kN] 0.08
Gypsum plasterboard	2 x 12.5 mm	[kN] 0.11





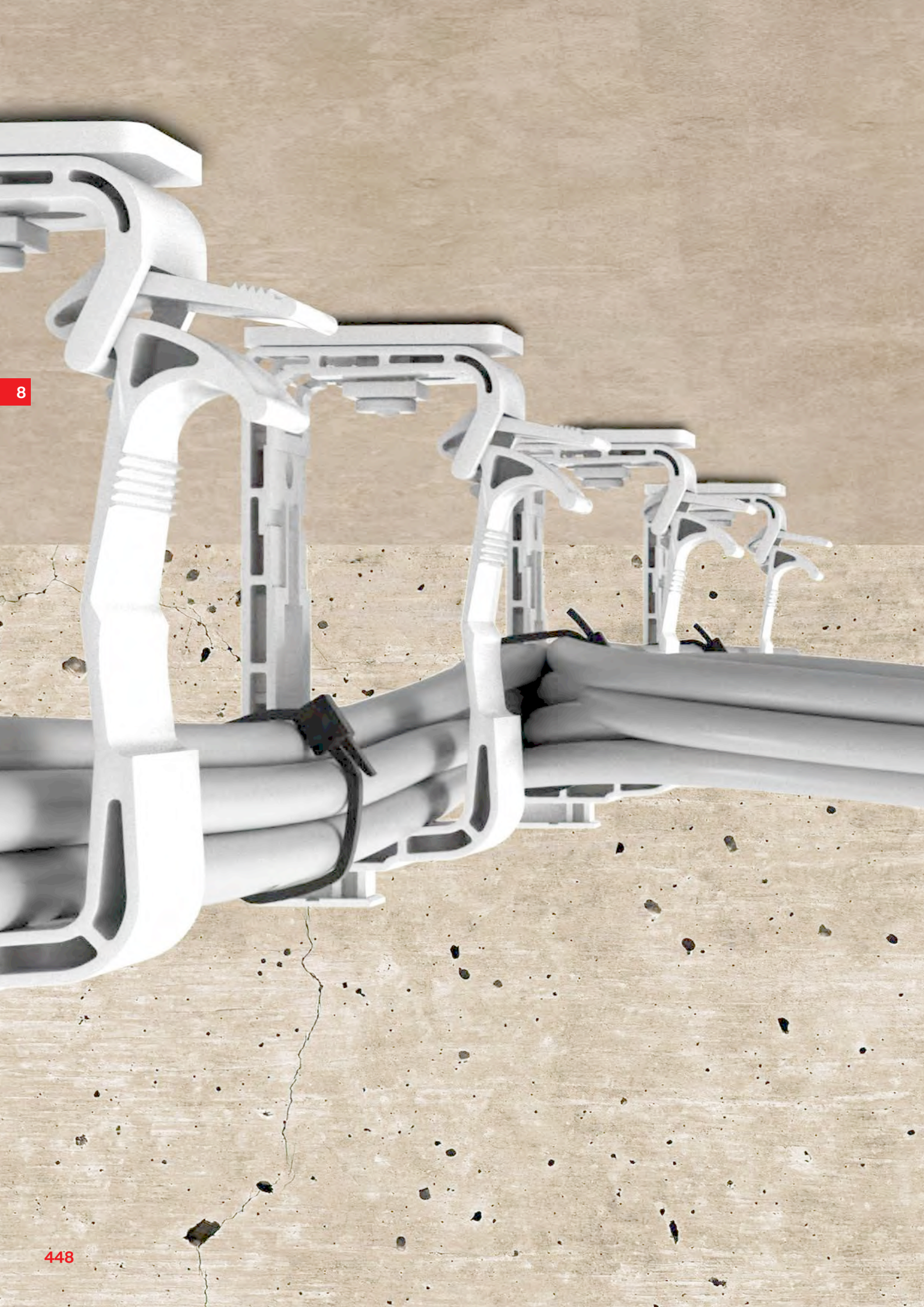















¹⁾ Required safety factors are considered. The given loads are valid for chipboard screws with the specified diameters.

²⁾ Valid for tensile load, shear load and oblique load under any angle.



8

Electrical fixings

Locking clip SCN	450		Nail disc NSB	472	
Pipe clip RC	452		Nail clip NS/MNS	474	
Pipe clip FC	454		Spacer pipe clamp AM/AMD	476	
Saddle clip SCH	456		Conduit clip BSM	479	
Fastening tie FF	458		Textile web strapping GWB	481	
ClipFix plus LS/ES/ZS	460		Perforated steel banding LBV / LBK	483	
ClipFix plus SD	462		Impact nail ED	485	
Cable clasp KB	464		Cable tie BN/GBN/UBN	487	
Cable harness SHA	466		Cable tie plug FCTP	489	
Multi cable support metal SHA M	468		Wireclip WIC	491	
Wall slot clip FWSC	470				

Locking clip SCN

The easy-to-install and secure locking clip for fixing of pipes



Plastic pipes



Plastic pipes

Applications

8

- Plastic, empty pipes
- Flexible and rigid electric tubes
- Aluminium-, copper- and steel pipes

Advantages

- When pressing, the locking clip SCN automatically embraces and locks the pipe, thus enabling convenient installation.
- The mechanical lock provides a secure and reopenable fixing.
- The integrated slotted hole allows for an easy and adjustable installation.
- The double-sided couplings allow several

- clips to be coupled together. This saves installation time and money.
- Flexible mounting with plugs and screws or with 11 mm C-profile rails.
- The durable nylon material is halogen- and silicone-free, allows year-round use even under frost and thus ensures a high level of safety.

Characteristics



Building materials

When using 2-component DuoPower plug:

- Concrete
- Solid brick
- Solid sand-lime brick
- Aerated concrete
- Vertically perforated brick
- Perforated sand-lime brick
- Plasterboard
- Gypsum plasterboard and gypsum fibreboards
- Hollow blocks made from lightweight concrete
- Cavity floor slabs made from bricks and concrete or similar
- Natural stone
- Chipboard
- Solid panel made from gypsum
- Solid brick made from lightweight concrete

Functioning

- The locking clip SCN is fixed in pre-positioned installation with a suitable plug and screw or in 11 mm C-profile rails.
- Due to the mechanical locking, the pipes are securely fixed with the clip.
- Installation temperature -20 °C + 60 °C
- Temperature resistance when installed -40 °C to +80 °C.

Versions

- Nylon

Installation SCN

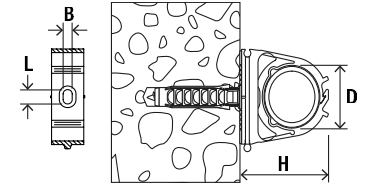
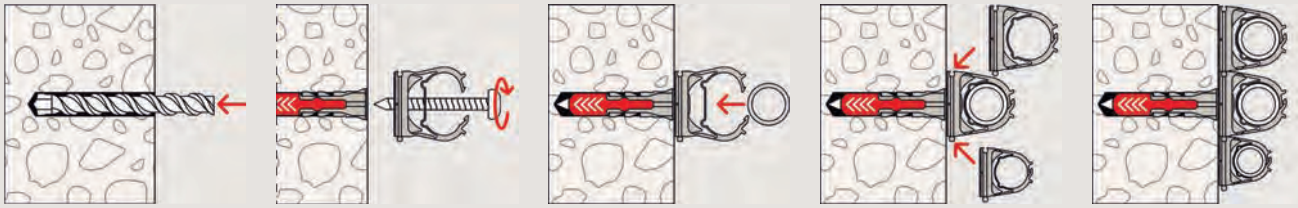

Technical data

Locking clip SCN



SCN

Item	Item No.	Pipe to wall distance [mm]	Clamping range D [mm]	Dimension of slot B x L [mm]	Height H [mm]	Sales unit [pcs]
SCN 16	501261	11	16	4,5 x 4,5	30	100
SCN 20	501262	11	20	4,5 x 6,5	36	100
SCN 25	501263	11	25	4,5 x 6,5	42	50
SCN 32	501264	13	32	4,5 x 7,5	48	50
SCN 40	501265	13	40	4,5 x 7,5	60	25
SCN 50	501266	14	50	4,5 x 7,5	73	25

Pipe clip RC

The convenient pipe fixing



Fixing plastic insulating conduits



Fixing plastic insulating conduits

8

Applications

- Flexible and rigid plastic insulating pipes

Advantages

- The pipe clip RC can be used with pre-installed clip fixing SD, with Hammerfix N 6 or in 11 mm C-shaped profile-rails, and thus allows for a flexible and cost-effective installation.
- The 6 mm-long hole allows for the optimal alignment of the pipe fixing and

- ensures a more user-friendly installation.
- Two additional pipe clips can be added to the sides of a pre-fixed pipe clip. This saves assembly time and materials.
- The long-lasting nylon material is halogen- and silicone-free. It can be used all year round, including during a frost. This ensures a high level of safety.

Characteristics



Building materials

When using ClipFix SD:

- Concrete
- Solid pumice block
- Solid sand-lime brick
- Natural stone with dense structure
- Solid brick

Functioning

- Plastic insulation pipes are laid into the pipe clip. The pre-tensioning of the pipe clip holds the pipes securely.
- The pipe clip RC is adapted to be fixed with either clip fixing SD or Hammerfix N 6.
- Manually place the ClipFix plus SD directly into the drill hole. No additional screws are needed.
- The Hammerfix N is expanded when the nail is driven in, and holds by friction in the drill hole.
- Temperature resistance once installed from -20 °C to +80 °C.

Installation RC

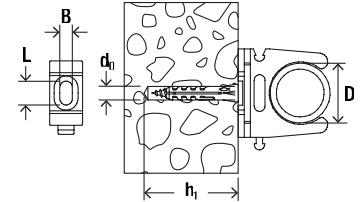
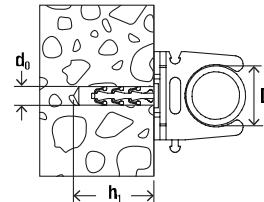
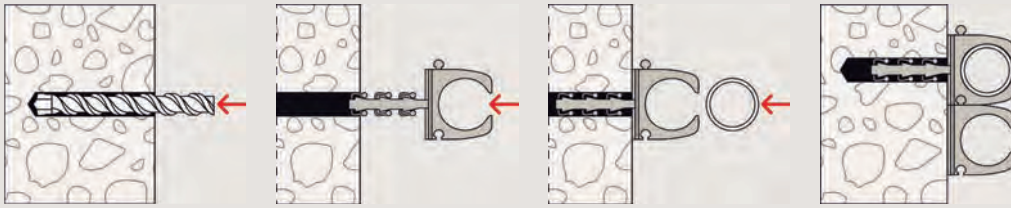

Technical data

Pipe clip RC



SF plus RC

RC

Item	Item No.	Drill hole d_0 [Ø mm]	Min. drill hole depth h_1 [mm]	Suitable for IEC	Clamping range D [mm]	Dimension of slot B x L [mm]	Sales unit [pcs]
SF plus RC IEC 12	048190	6	35	12	12 - 13	6 x 7	100
SF plus RC IEC 16	048191	6	35	16	15 - 16	6 x 8	100
SF plus RC IEC 19	553383	6	35	19	18 - 19	6 x 10	100
SF plus RC IEC 20	048193	6	35	20	20 - 21	6 x 10	100
SF plus RC IEC 25	048197	6	35	25	24 - 25	6 x 10	50
SF plus RC IEC 32	048198	6	35	32	31 - 32	6 x 10	25
SF plus RC IEC 40	048199	6	35	40	38 - 40	6 x 10	25
RC IEC 12	058194	—	—	12	12 - 13	6 x 7	100
RC IEC 16	058120	—	—	16	15 - 16	6 x 8	100
RC IEC 19	553363	—	—	19	18 - 19	6 x 10	100
RC IEC 20	058122	—	—	20	20 - 21	6 x 10	100
RC IEC 25	058198	—	—	25	24 - 25	6 x 10	50
RC IEC 32	058199	—	—	32	31 - 32	6 x 10	40
RC IEC 40	058200	—	—	40	39 - 40	6 x 10	40
RC IEC 50	079194 ¹⁾	—	—	50	50 - 51	6 x 10	20
RC IEC 63	079196 ¹⁾	—	—	63	62 - 64	6 x 10	15

1) Does not include latching catches, therefore cannot be mounted side by side.

Pipe clip FC

The flexible pipe clip for various diameters

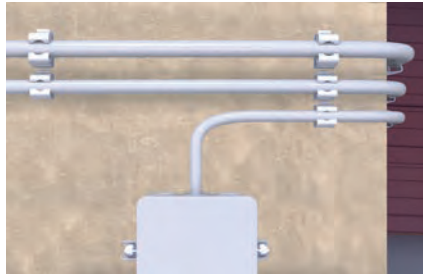

Cable fixing

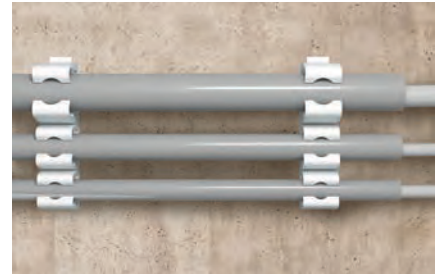

Fixing plastic insulating conduits

Applications

- Electric cables
- Flexible and rigid plastic insulating pipes

Advantages

- The flexible pipe clip socket ensures a secure hold for various cable and pipe diameters, and reduces the number of products required.
- The pipe clip FC can be installed with both N 5 Hammerfixes and 11 mm-C-shaped profile-rails, and thus offers great

flexibility.

- Two additional pipe clips can be added to the sides of a pre-fixed clip clamp. This saves assembly time and materials.
- The long-lasting nylon material is halogen-free. It can be used all year round, including during a frost. This ensures a high level of safety.

Characteristics



Building materials

When using Hammerfix N:

- Concrete
- Vertically perforated brick
- Hollow blocks made from lightweight concrete
- Perforated sand-lime brick
- Solid sand-lime brick
- Building brick
- Natural stone
- Aerated concrete
- Solid panel made from gypsum
- Solid brick made from lightweight concrete

Functionality

- The clip clamp FC is adapted to suit the fixture using N5 Hammerfixes.
- The Hammerfix N is expanded when the nail is driven in, and holds by friction in the drill hole.
- The cables or pipes are then laid in the clip clamp FC. The pre-tensioning of the clip clamp holds the cables or pipes securely.
- Temperature resistance once installed from -40 °C to +80 °C.

Installation FC

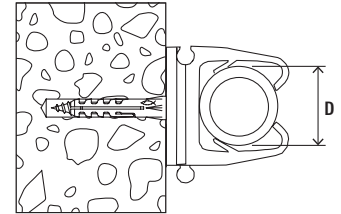
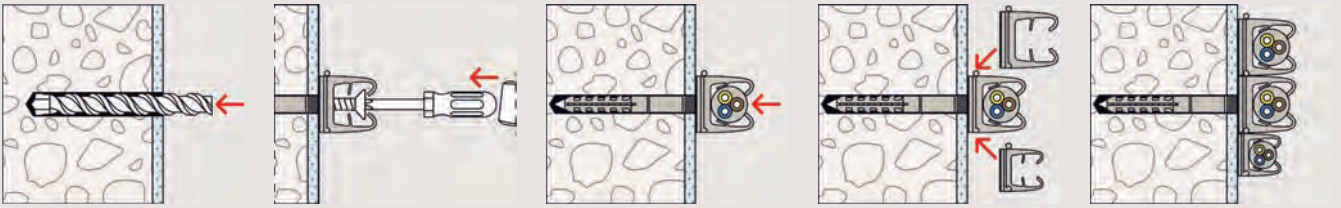

Technical data

Pipe clip FC



FC

Item	Item No.	Clamping range	Sales unit
		D [mm]	[pcs]
FC 6 - 9 GR	068060	6 - 9	100
FC 9 - 12 GR	068062	9 - 12	100
FC 12 - 16 GR	068064	12 - 16	50
FC 16 - 20 GR	068066	16 - 20	25

Saddle clip SCH

The flexible cable clamp for various diameters

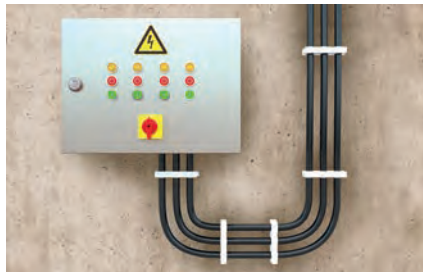

Fixing cable harnesses

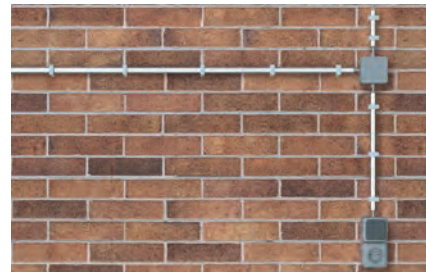

Plastic conduits

Applications

8

- Electric cables
- Flexible and rigid plastic insulating pipes

Advantages

- With its elastic spring tabs, the saddle clip SCH can bear different cable diameters. This increases flexibility and reduces the number of products required.
- Additional clips can be added to the sides of a pre-fixed clip. This saves installation

time and materials.

- The long-lasting nylon material is halogen- and silicone-free. It can be used all year round, including during a frost. This ensures a high level of safety.

Characteristics



Building materials

When using Hammerfix N:

- Concrete
- Vertically perforated brick
- Hollow blocks made from lightweight concrete
- Perforated sand-lime brick
- Solid sand-lime brick
- Building brick
- Natural stone
- Aerated concrete
- Solid panel made from gypsum
- Solid brick made from lightweight concrete

Functionality

- The clamp SCH is adapted to suit the fixture using N 5 Hammerfixes.
- The Hammerfix N is expanded when the nail is driven in, and holds by friction in the drill hole.
- The cables or pipes are then laid in the clamp SCH and fixed by inserting the locking latch.
- The internal tabs adapt to fit various cable or pipe diameters.
- Temperature resistance once installed from -40 °C to +80 °C.

Installation SCH

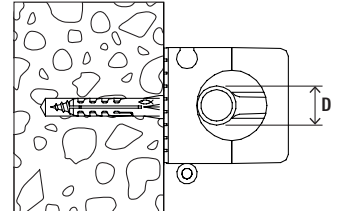
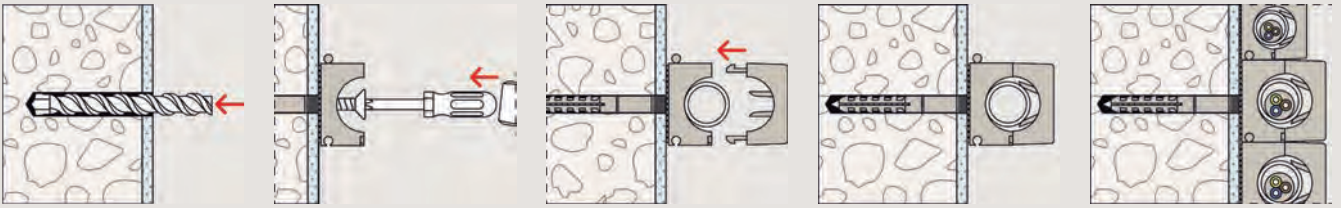

Technical data

Saddle clip SCH



SCH, colour Nylon transparent



SCH, colour grey RAL 7035

Item	Grey RAL 7035	Nylon transparent	Clamping range D [mm]	Dimension of insulated pipes	Sales unit
	Item No.	Item No.			
SCH 812	068012	060012	8 - 12	6 x 1 - 8 x 1	100
SCH 1216	068016	060016	12 - 16	10 x 1 - 12 x 1	50
SCH 1619	068019	069019	16 - 19	—	50
SCH 1623	068023	060023	16 - 23	15 x 1 - 18 x 1	50
SCH 2332	068032	060032	23 - 32	22 x 1 - 22 x 1,5	25
SCH 3242	—	060042	32 - 42	22 x 1 - 22 x 1,5	25

Fastening tie FF

Fixing tie for bundling and fixing of cables and pipes to the substrate

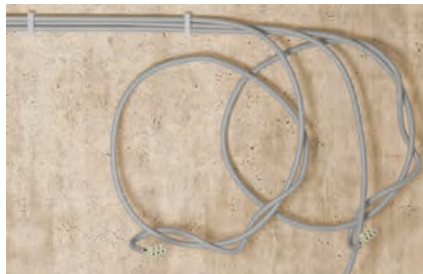

Electric cables



Plastic pipes

Applications

8

- Electric cables
- Flexible and rigid electric tubes
- Steel conduits

Characteristics



Advantages

- The socket of the FF fixing tie is fixed to the substrate with a screw or screw and plug.
- The fixing tie can be used to bundle and

- fix several cables or pipes.
- Adjustable diameter of the tie loop.
- The socket of the fixing tie can be adjusted through its slotted hole.

Building materials

When using 2-component DuoPower plug:

- Concrete
- Solid brick
- Solid sand-lime brick
- Aerated concrete
- Vertically perforated brick
- Perforated sand-lime brick
- Plasterboard
- Gypsum plasterboard and gypsum fibreboards
- Hollow blocks made from lightweight concrete
- Cavity floor slabs made from bricks and concrete or similar
- Natural stone
- Chipboard
- Solid panel made from gypsum
- Solid brick made from lightweight concrete

Functioning

- The Socket of the fixing tie is fixed with the plug and screw suitable for the substrate.
- Recommended application temperature -20 °C to +60 °C.
- Temperature resistant when installed -40 °C to +80 °C.

Installation FF

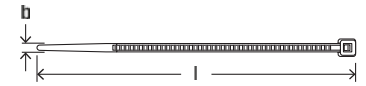
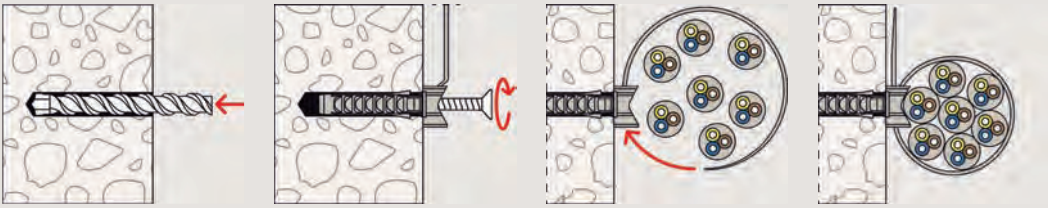

Technical data

Fastening tie FF



FF

Item	Item No.	Length	Dimension fixing base	For cables and pipes from / to $d_{\min} - d_{\max}$ [Ø mm]	max. screw diameter	Sales unit
		L [mm]	[mm]		[mm]	[pcs]
FF 8 - 32	519808	172	25 x 15 x 20	8 - 32	4,5	80
FF 16 - 63	519809	270	25 x 15 x 20	16 - 63	4,5	40

ClipFix plus LS/ES/ZS

The user-friendly clip fixing for pipes and conduits



Cable fixing



Fixing flexible pipes

8 Applications

- Individual electric cables
- Cable bundles
- Flexible pipes
- Rigid plastic pipes

Advantages

- The complete element combines anchor, screw and clamp. This saves materials, allows for one-handed installation, and reduces assembly time.
- The slimline geometry of the fixing element only protrudes slightly, thus saving space.
- The three different sizes of each of the

cable strap LS, twin clamp ZS and single clamp ES cover a range of cable diameters, thus reducing storage.

- The long-lasting nylon material is flame resistant, halogen- and silicone-free, can be used all year round, including during a frost. This ensures a high level of safety.

Characteristics



Building materials

- Concrete
- Solid pumice block
- Solid sand-lime brick
- Natural stone with dense structure
- Solid brick

Functioning

- The clip fixing is set into the drill hole without the need for any additional screws and fixes the pipe directly to the base material.
- The clamping force of the locking catch allows the ClipFix to hold itself in the drill hole.
- Place the clasp of the cable strap LS into the drill hole so that it is level and the teeth grip.
- Recommended loads (required safety factor considered): cable strap LS up to 6 kg, twin clamp ZS and single clamp ES up to 11 kg.
- Temperature resistance once installed from -20 °C to +80 °C.
- Flammability material UL 94-V0.

Installation LS/ES/ZS

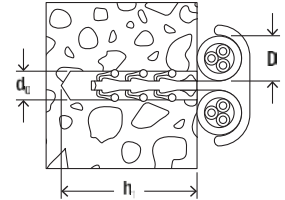
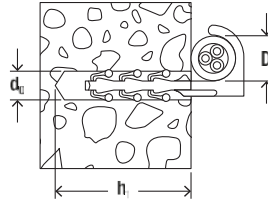
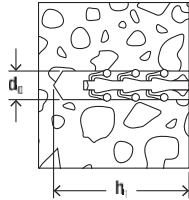

Technical data

ClipFix plus LS/ES/ZS



SF plus LS



SF plus ES



SF plus ZS

Item	Item No.	Drill hole d_0 [Ø mm]	Min. drill hole depth h_1 [mm]	Clamping range D [mm]	Sales unit [pcs]
SF plus LS 3/13	058155	6	35	3 - 13	100
SF plus LS 8/28	058156	6	50	8 - 28	100
SF plus LS 20/40	058157	6	50	20 - 40	100
SF plus ES 10	048151	6	40	3 - 12	100
SF plus ES 18	048152	6	40	10 - 25	100
SF plus ES 28	058183	6	40	15 - 31	100
SF plus ZS 10	058184	6	35	3 - 12	100
SF plus ZS 18	048161	6	40	10 - 25	100
SF plus ZS 28	048162	6	40	15 - 31	75

ClipFix plus SD

The user-friendly clip fixing for cable ducts and cable clasps

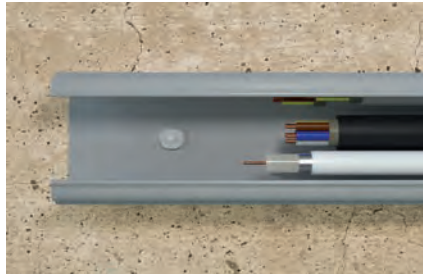

Fixing cable ducts



Fixing cable harnesses

Applications

8

- Cable channels
- Cable clasps
- Installation base cable harness
- Flat building components

Advantages

- The ClipFix plus SD combines anchor and screw. This saves on materials and makes it easier to affix cable ducts that are difficult to access without the need for additional tools.
- The simple clip fixing reduces installation time.
- The extended shank of the FS plus SD 40

- allows bridging of non-bearing plaster layers, as well as the fixing of thicker attachments.
- The long-lasting nylon material is flame resistant, halogen- and silicone-free. It can be used all year round, including during a frost. This ensures a high level of safety.

Characteristics



Building materials

- Concrete
- Solid pumice block
- Solid sand-lime brick
- Natural stone with dense structure
- Solid brick

Functioning

- To fix, manually place the ClipFix plus SD directly into the drill hole. No additional screws are needed.
- The clamping force of the locking catch allows the ClipFix to hold itself in the drill hole.
- Recommended loads (required safety factor considered): clip fixing SD up to 11 kg.
- Temperature resistance once installed from -20 °C to +80 °C.
- Flammability material UL 94-V0.

Installation SD

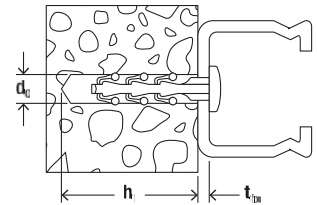
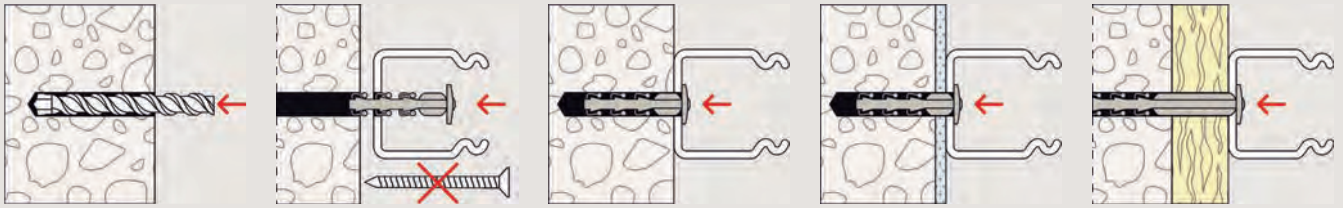

Technical data

ClipFix plus SD



SF plus SD

Item	Item No.	Drill hole d_0 [Ø mm]	Min. drill hole depth h_1 [mm]	Max. usable length t_{fix} [mm]	Sales unit [pcs]
SF plus SD 30	058178	6	35	4	200
SF plus SD 40	058179	6	35	15	100

Cable clasp KB

The flat cable clasp for space-saving cable fixing



Fixing cable harnesses



Fixing cable harnesses

8

Applications

- Several individual cables in a small installation space
- Multiple single cables in false ceilings

Characteristics



Advantages

- The flat design of the KB cable clasp allows for a space-saving cable fixing, and simplifies subsequent cable-laying.
- The combination of cable clasp KB and ClipFix SD allows for one-handed installation, thus enabling a flexible and

economic installation.

- The long-lasting nylon material is halogen- and silicone-free. It can be used all year round, including during a frost. This ensures a high level of safety.

Building materials

When using ClipFix SD:

- Concrete
- Solid pumice block
- Solid sand-lime brick
- Natural stone with dense structure
- Solid brick

Functionality

- The cable clasp KB is adapted to suit the fixture with clip fixing SD or Hammerfix N6.
- Place the ClipFix plus SD directly into the drill hole by hand. No additional screws are needed.
- The Hammerfix N is expanded when the nail is driven in, and holds by friction in the drill hole.
- After installation, the cables are pulled under the clasp. Additional cables can be easily laid after installation too.
- Temperature resistance once installed from -20 °C to +80 °C.

Installation KB

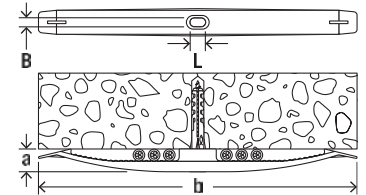
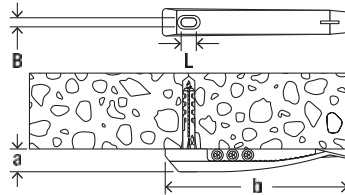
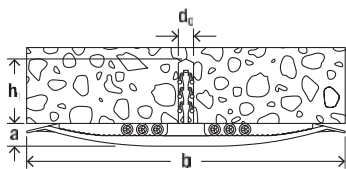
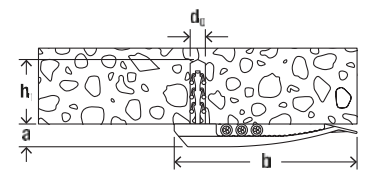
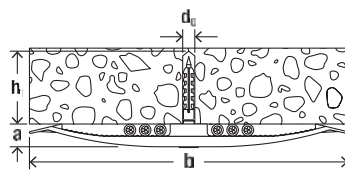
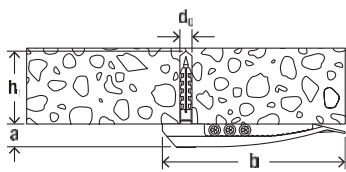
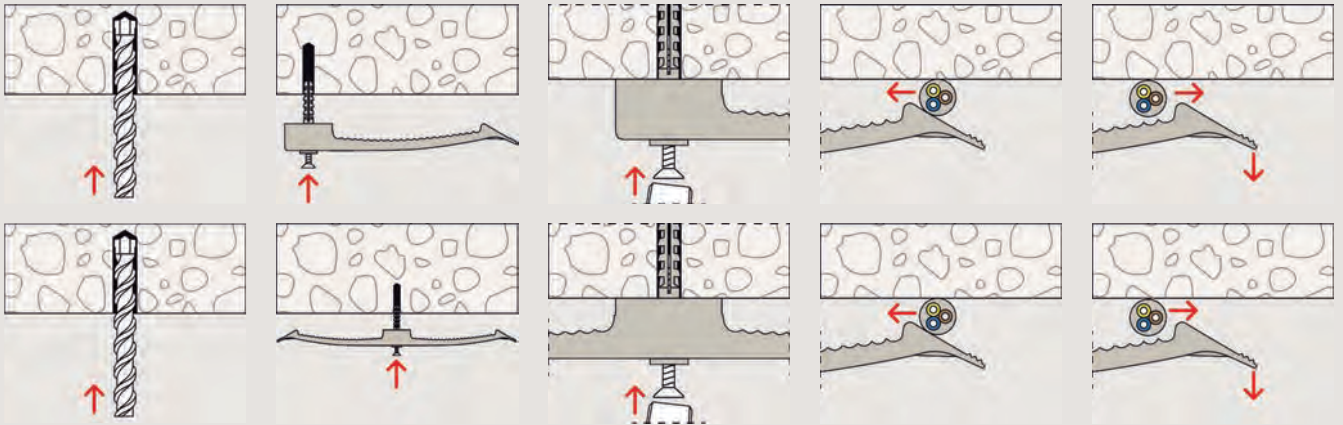

Technical data

Cable clasp KB



Item	Item No.	Drill hole d_0 [Ø mm]	Min. drill hole depth h_1 [mm]	Dimensions $a \times b$ [mm]	Dimension of slot $B \times L$ [mm]	Max. number of ducts	Sales unit [pcs]
KB N 8	545522	6	35	15 x 133	6 x 10	8 ducts NYM 3 x 1,5	50
KB N 16	545523	6	35	15 x 133	6 x 10	16 ducts NYM 3 x 1,5	25
SF plus KB 8	048171	6	35	15 x 133	6 x 10	8 ducts NYM 3 x 1,5	50
SF plus KB 16	048172	6	35	15 x 230	6 x 10	16 ducts NYM 3 x 1,5	25
KB 8	058135	—	—	15 x 133	6 x 10	8 ducts NYM 3 x 1,5	50
KB 16	058136	—	—	15 x 230	6 x 10	16 ducts NYM 3 x 1,5	50

Cable harness SHA

The adaptable cable harness for fixing cable bundles



Fixing cable bundles

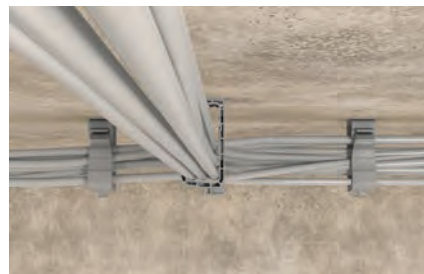

Fixing cable bundles

8

Applications

- Electric cables, loose and bundled

Advantages

- Simple bundling and economical laying of multiple electric cables.
- The seal of the cable harness SHA makes it easy to lay cables at a later date, thus ensuring high user-friendliness.
- Combining several SHA cable harnesses allows for a cost-effective fixing of cables

- to just one MS installation base.
- The MS installation base allows for various fixing options, and offers great flexibility for the installation.
- The long-lasting nylon material is halogen- and silicone-free, can be used all year round, including during a frost, and thus ensures a high level of safety.

Characteristics



Building materials

When using ClipFix SD:

- Concrete
- Solid pumice block
- Solid sand-lime brick
- Natural stone with dense structure
- Solid brick

Functioning

- Cable bundles can be laid in the cable harness SHA. The seal makes it easy to lay cables at a later date.
- The cable harness SHA can either be affixed with ClipFix plus, installation base MS or with plugs and screws.
- Several SHA cable harnesses can be combined below one another.
- The SHA cable harnesses can also be lined up adjacent to one another with the connection piece SHA KP.
- The maximum installation distance of 80 cm must not be exceeded.
- Temperature resistance once installed from -20 °C to +80 °C.

Installation SHA

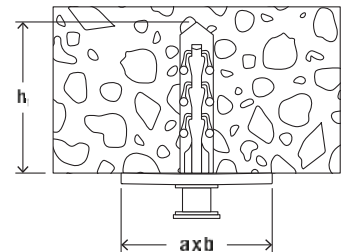
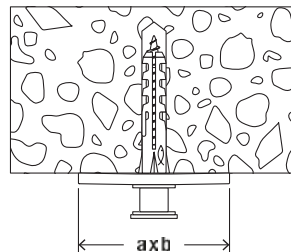
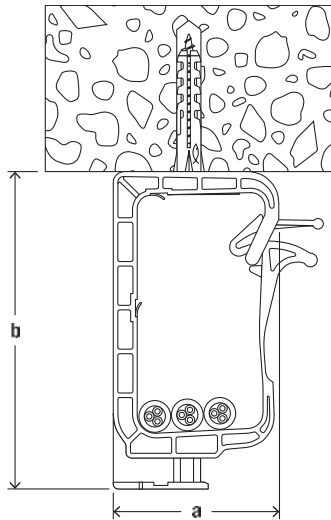
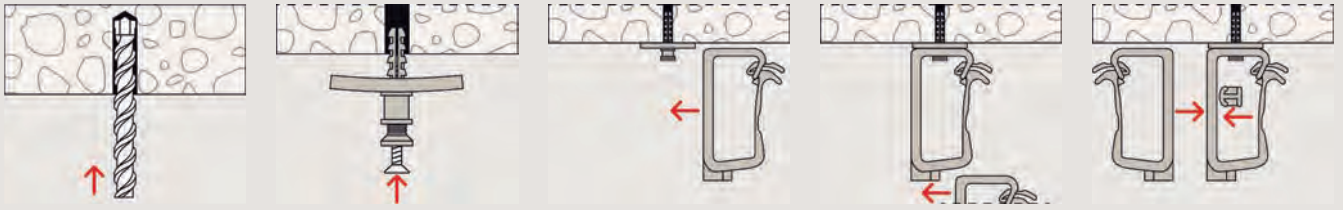

8

Technical data

Cable harness SHA



SHA



SHA MS



SF plus MS



SHA KP

Item	Item No.	Drill hole d_0 [Ø mm]	Min. drill hole depth h_1 [mm]	Dimensions a x b [mm]	Max. number of ducts	Sales unit [pcs]
SHA 15	058139	—	—	93 x 49	15 ducts NYM 3 x 1,5	50
SHA 30	058140	—	—	128 x 59	30 ducts NYM 3 x 1,5	25
SHA MS	058141	—	—	41 x 27	connection piece	50
SF plus MS	048181	6	35	41 x 27	installation base with clip-plug	50
SHA KP	058142	—	—	—	installation base	50

Multi cable support metal SHA M

Metal multi-cable support with high mechanical resistance and approval



Cable fixing to the ceiling



Cable fixing to the wall

Applications

8

- Cables with circuit integrity maintenance
- Installation of electrical cables above fire protection ceilings.

Advantages

- The fischer metal multi cable support SHA M has a high mechanical strength and thus offers a long service life and safety in the event of fire.
- It is approved as a cable-specific variant for circuit integrity maintenance of electric cable systems in accordance with DIN 4102 Part 12.
- This makes it suitable for safe installation

- above fire protection ceilings.
- Depending on the version, 15, 30 or 70 cables can be fixed.
- The lock, which can be operated without tools, allows easy subsequent cable-laying and thus ensures a high degree of ease of installation.
- The multi cable support is variably suitable for wall and ceiling installation.
- Halogen-free and without fire load.

Characteristics

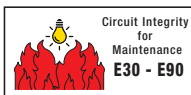

Functioning

- The multi cable support is fixed to walls or ceilings with plugs and screws or metal anchors suitable for the substrate and application.

Installation SHA M

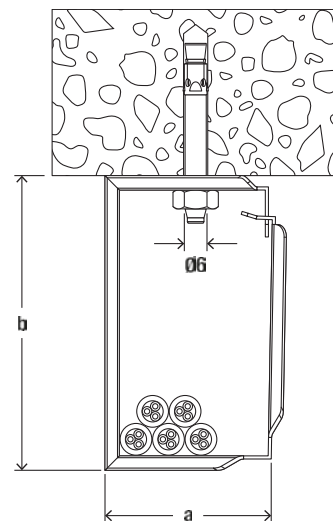

8

Technical data

Multi cable support metal SHA M



SHA M

Item	Item No.	Mounting pipe Ø [mm]	Dimension in [mm]	Max. number of ducts	Sales unit [pcs]
SHA M 15	544933	6	66,7 x 41,9 x 30,6	15 ducts NYM 3 x 1,5	50
SHA M 30	544934	6	92,8 x 58,1 x 33,6	30 ducts NYM 3 x 1,5	25
SHA M 70	544935	6	126,0 x 104,0 x 80,0	70 ducts NYM 3 x 1,5	10

Wall slot clip FWSC

The quick tool-free cable fixing in wall slots



Cable fixing in wall slots > 30 mm



Cable fixing in wall slots < 55 mm

Applications

8

- Cables in wall slots of 30 - 55 mm width

Advantages

- With the fischer FWSC wall slot clip, cables can be fixed quickly and without tools in wall slots 30 to 55 mm wide.
- This reduces installation time by up to 50%.
- The high expansion power of the wall slot clip guarantees a reliable fixing of the

Building materials

- Concrete
- Masonry

Versions

- POM, recyclable

cables.

- Damage to the cables can be excluded due to the expansion principle.
- Thanks to its neutral colour, the wall slot clip does not shine through the plaster.
- The wall slot clip is made of halogen-free material.

Functioning

- The cables to be fastened are inserted into the wall slot.
- By pressing together the wall slot clip is compressed and tensed to be ready for installation in the wall slot.
- The wall slot clip can be compressed in length or width as required and thus used for wall slots with a width of 30 to 55 mm.

Installation FWSC

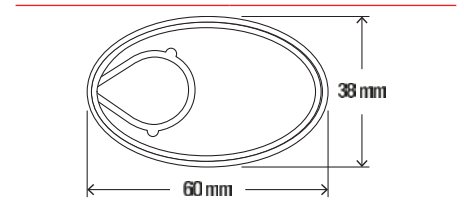
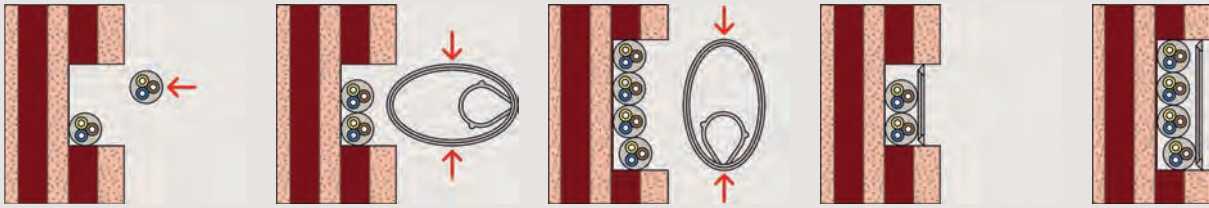

Technical data

Wall slot clip FWSC



FWSC

Item	Item No.	Max. slot width [mm]	Dimension in [mm]	Sales unit [pcs]
FWSC 30 - 55	545792	55	38 x 60 x 4	50

Nail disc NSB

The secure cable fixing in wall slots



Cable fixing

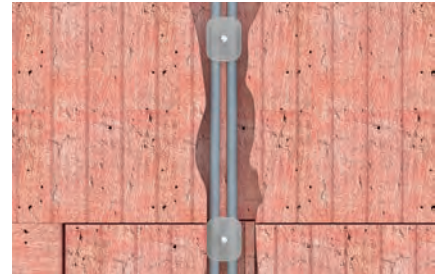

Cable fixing in slits

Applications

8

- Cables in wall slots

Advantages

- The nail disc NSB allows for use in two slot widths.
- The vaulted structure of the nail disc ensures an optimal contact pressure and, as such, for a secure hold.
- The flat nail disc only protrudes slightly,

- and can thus be easily plastered over.
- The nail disc NSB is made from high-strength polypropylene. The nail is made from hardened, galvanised steel. The tried and tested material combination for in-wall installation.

Building materials

- Vertically perforated brick
- Pumice
- Lightweight aggregate concrete
- Aerated concrete
- Hardboard
- Wood
- Chipboard
- Plywood
- Solid panel made from gypsum

Functionality

- Remove cable.
- Align the nail disc with either dimensions 27 mm or 34 mm, depending on the slot width, and hit the nail in with a hammer.
- The cables are fixed in the wall slots by the curved washer.

Installation NSB

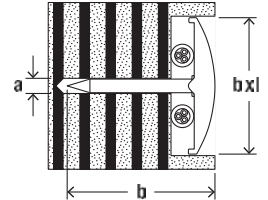
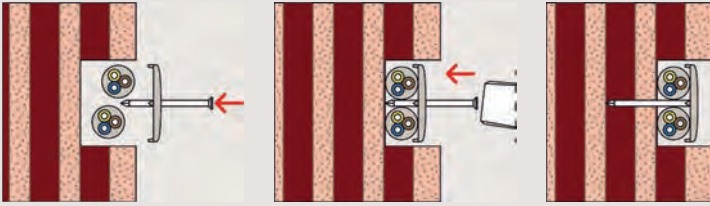

Technical data

Nail disc NSB



NSB

Item	Item No.	Dimension of nail a x b [mm]	Dimension of disc b x l [mm]	Sales unit [pcs]
NSB 2/40	048308	2 x 40	27 x 34	200
NSB 2/50	048309	2 x 50	27 x 34	150
NSB 2/60	048310	2 x 60	27 x 34	100
NSB 3/40	048311	3 x 40	27 x 34	150
NSB 3/50	048312	3 x 50	27 x 34	150
NSB 3/60	048313	3 x 60	27 x 34	100

Nail clip NS/MNS

The fast fixing for electric cables



Cable fixing



Cable fixing

Applications

8

- Electric cables with varying diameters

Advantages

- The nail clip features a pre-assembled zinc-plated nail, allowing for a fast fixing, thus reducing assembly time.
- The small space required for fixing simplifies

installation in narrow spaces.

- The nail clip MNS covers cable diameters from 4 mm to 14 mm with just 3 sizes.

Building materials

- Hardboard
- Wood
- Aerated concrete
- Chipboard
- Plywood
- Solid gypsum panels and other plastered substrates

Functioning

- Position the nail clip with the laid cable. Hammer in the pre-assembled nail with a hammer.

Installation NS/MNS

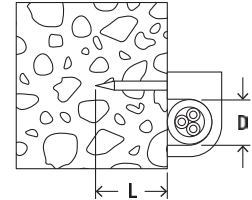
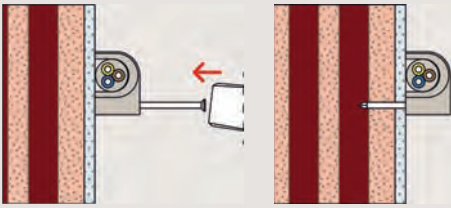

Technical data

Nail clip NS/MNS



NS

MNS

Item	Item No.	For cable [Ø mm]	Clamping range D [mm]	Length of nail L [mm]	Sales unit [pcs]
NS 7	058173	7	7	25	100
NS 8	058174	8	8	25	100
NS 9	058175	9	9	25	100
NS 10	058176	10	10	30	100
NS 12	058177	12	12	35	100
MNS 4-7	094673	—	4 - 7	25	100
MNS 7-11	094674	—	7 - 11	25	100
MNS 10-14	094675	—	10 - 14	30	100

Spacer pipe clamp AM/AMD

The installation-friendly metal spacing disc for cables and pipes



Fixing steel armoured conduits



Fixing conduits

Applications

8

- Steel conduits
- Electric cables
- Copper and metal pipes

Advantages

- The fast-locking latch ensures easy opening and closing without completely removing the screw, and allows for a simple and fast installation.
- The pre-fitted combination screw with

conventional slotted or recessed screw head allows for the use of different screwdrivers, thus allowing for a simple installation.

Building materials

When using nail anchor FNA II:

- Concrete
- Solid sand-lime brick
- Natural stone with dense structure
- Pre-stressed concrete hollow slabs

When using Hammerfix N:

- Concrete
- Solid sand-lime brick
- Building brick
- Natural stone
- Solid brick made from lightweight concrete

Functioning

- The spacer clamp AM with M6 thread can either be affixed with fischer nail anchor FNA II 6x30 M6x43, stud screw STST 6x60 and STST 6x80 or with Hammerfix N 6x40/10 M6.

Installation AM/AMD

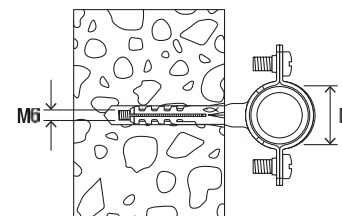
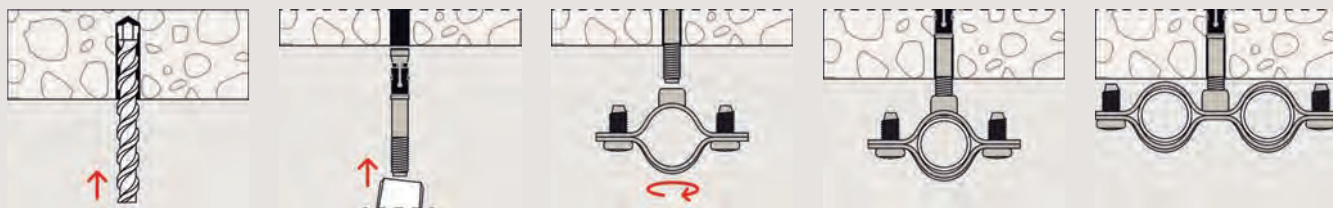

Technical data

Spacer pipe clamp AM



AM

Item	Item No.	Dimension IEC	Clamping range D [mm]	Sales unit [pcs]
AM 8	060185	—	8 - 10	50
AM 10	060186	—	10 - 11	50
AM 12	060187	12	12 - 13	50
AM 14	060188	—	14 - 15	50
AM 16	060189	16	15 - 17	50
AM 18	060190	—	18 - 19	50
AM 20	060191	20	20 - 21	50
AM 22	060192	—	22 - 23	50
AM 24	060193	—	24 - 25	50
AM 26	060194	25	26 - 27	50
AM 28	060195	—	28 - 29	50
AM 30	060196	—	30 - 31	50
AM 32	060209	32	32 - 33	25
AM 34	060210	—	34 - 35	25
AM 37	060211	37	37 - 39	20
AM 40	090849	40	40 - 42	15
AM 50	090850	50	50 - 52	10
AM 63	090851	63	63 - 65	10

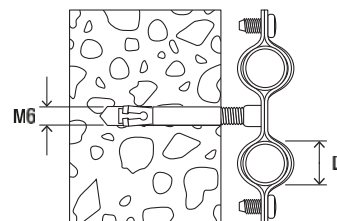

Technical data

Spacer pipe clamp AMD



AMD

Item	Item No.	Clamping range D [mm]	Sales unit [pcs]
AMD 10 - 12	545772	10 - 12	25
AMD 14 - 16	545773	14 - 16	25
AMD 17 - 19	545774	17 - 19	25
AMD 20 - 23	545775	20 - 23	25
AMD 24 - 27	545776	24 - 27	25

Conduit clip BSM/BSMD/BSMZ

The flat metal clip for cables and pipes



Fixing armoured conduits

Applications

- Electrical conduits
- Flexible and rigid plastic insulating pipes
- Steel conduits

Advantages

- The open conduit clip BSM is ideal for the post-installation fixing of conduits.
- The conduit clip allows for a direct fixing with impact nails and is, therefore, quick

Building materials

When using impact nail ED:

- Concrete

and easy to install.

- Two conduits or pipes can be fixed with just one fixing point with the twin clamp BSMZ.

Functioning

- Depending on your requirements, use a conduit clip with 1 or 2 fixing points, or a twin clamp.
- The conduits or pipes are laid in the conduit clip. Assembling the clip fixes the conduits / pipes.
- Our recommendation for fixtures on concrete: Impact nail.

Installation BSM/BSMD/BSMZ

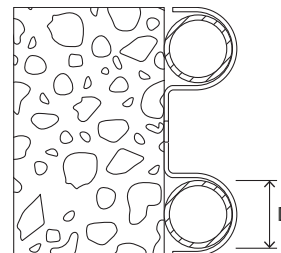
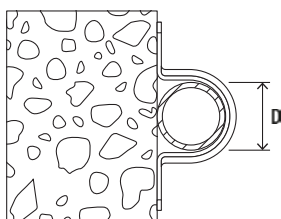
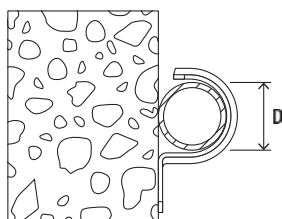

8

Technical data

Conduit clip BSM / BSMD / BSMZ



BSM



BSMD



BSMZ

Item	BSM	BSMD	BSMZ	Dimension IEC	Clamping range	Sales unit
	Item No.	Item No.	Item No.		D	
					[mm]	
6	015014	—	—	—	6	100
8	015015	—	—	—	8	100
10	015016	—	—	—	10	100
12	015017	015069	—	—	12	50
14	015018	015070	—	—	14	50
15	015093	—	—	15	15	50
16	060149	060169	—	16	16	50
18	060150	060170	—	—	18	50
20	060151	060171	079535	20	20	50
22	060152	060172	—	—	22	50
24	060153	—	079536	—	24	50
25	090839	090844	—	25	25	50
26	096958	015076	—	—	26	50
28	060155	—	079537	—	28	50
30	015019	—	—	—	30	50
32	090840	—	—	32	32	50
37	060158	060178	—	—	37	25
40	090841	090846	—	40	40	25
42	015021	—	—	—	42	25
50	090842	—	—	50	50	20
63	090843	—	—	63	63	15
10	—	015068	—	—	10	50
28	—	060175	—	—	28	25
32	—	090845	—	32	32	25
42	—	015081	—	—	42	20
47	—	015082	—	—	47	20
50	—	090847	—	50	50	15
63	—	090848	—	63	63	10

Textile web strapping GWB

Textile web strapping GWB for cost-effective, easy pipe fixings



Flexible and rigid plastic insulation pipes

Applications

- Pipelines
- Flexible and rigid plastic pipes
- Compound pipes

Properties

- Material: polypropylene

Advantages/benefits

- Pipe fastening using textile tape allows cheap and simple installation.
- The textile tape roll allows the correct tape length to be chosen to suit the diam-

Building materials

When using impact nail ED:

- Concrete

- eter in question.
- Hangings with textile tape are a fast solution for temporary fixings.

Installation GWB

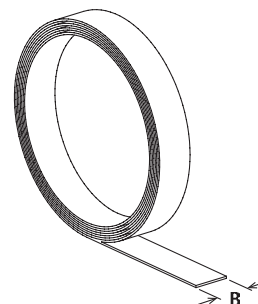

8

Technical data

Textile web strapping GWB



GWB

Item	Item No.	Total length l [mm]	Width B [mm]	Thickness S [mm]	Sales unit [pcs]
GWB	020959	10000	15	1.1	10

Perforated steel banding LBV/LBK

Perforated steel banding LBV / LBK for the fast fixing of pipelines



Plastic pipes

Applications

- Steel tape with stamped holes for simple installation; available zinc-plated LBV or plastic-covered LKB
- The fischer nail anchor FNA II is suitable for ceiling fixing in concrete
- Use fischer thread hanger RAH for fastening to threaded rods

Properties

- Material: DX51D+Z 100 (material no. 1.0917) acc. to DIN EN 10.346 For Type LBW17: Q235
- Zinc plating: electro zinc-plated, min. 5 µm
- Protective coating LBK: PE

Advantages/benefits

- The perforated tape's material thicknesses and plastic covering allows the tapes to be easily cut to size using metal

Building materials

- When using impact nail ED:
- Concrete

- shears.
- The perforated tape's hole geometry enables concrete fixing using the fischer impact nail ED.

Installation LBV/LBK

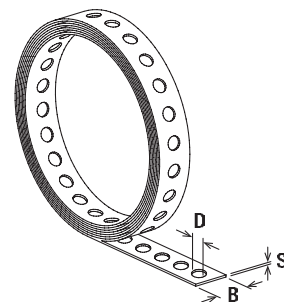

8

Technical data

Perforated steel banding LBV/LBK



LBV

LBK

Item	Item No.	Total length l [mm]	Width B [mm]	Thickness S [mm]	Eye-Ø D [mm]	Sales unit [pcs]
LBV 12	079549	10000	12	0.75	5	10
LBV 17	079550	10000	17	0.75	6.5	10
LBV 25	079551	10000	25	0.88	8.5	8
LBK 14	079553	10000	14	2.6	5	10
LBK 19	079554	10000	19	2.4	6.5	8
LBK 27	079555	10000	27	2.4	8.5	5

Impact nail ED

Fixing in concrete without pre-drilling



Fixing armoured conduits



Fixing perforated tapes

Applications

- Conduit clips such as BSM, BSMD, BSMZ
- Perforated band such as LBK, LBV

Advantages

- The stable impact nail ED can be set in concrete with the impact nail setting tool SZE without pre-drilling. This allows for a

fast installation.

- The setting tool SZE impact protection provides the best protection for your hand, thus ensuring a safe installation.

Building materials

- Concrete

Functionality

- The impact nail ED is set in the setting tool SZE.
- The bracket in the setting tool holds the nail securely in place during the installation procedure.
- Pre-positioning of the element to be fixed.
- The nail can be hammered through the fixing element directly into the concrete.

Installation ED

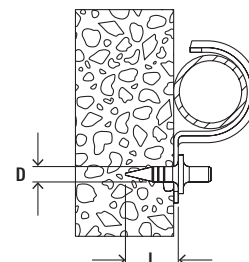

8

Technical data

Impact nail ED



ED

Item	Item No.	Length L [mm]	Diameter d [mm]	Sales unit [pcs]
ED 15	048212	15	4.0	200
ED 18	079815	18	4.0	200
ED 22	014570	22	4.0	200

Technical data

Impact nail setting tool SZE



SZE

Toolset for SZE

Item	Item No.	Sales unit [pcs]
SZE	552149	1
Toolset for SZE	552150	3

Cable tie BN/GBN/UBN

For the simple bundling of cables and pipes

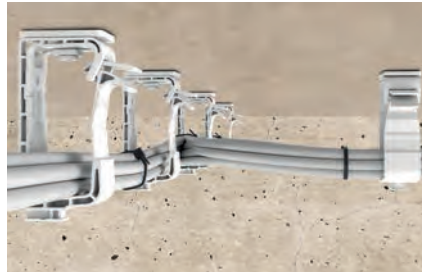

Bundling electric cables



Electric cables

Applications

For bundling of:

- Electric cables
- Flexible and rigid plastic insulating pipes
- Steel conduits

Advantages

- The long-lasting nylon material is halogen- and silicone-free.
- The cable tie UBN (black) is made from

UV-stabilised material.

Characteristics



Functioning

- Lie the cable tie around the object to be fixed, and pull the band through the head of the cable tie. The cable tie can no longer be opened due to the latching of the tab in the teeth.
- Temperature resistance once installed from -10 °C to +85 °C.
- Recommended installation temperature from -10 °C to +85 °C.
- Flammability material UL 94-V2.

Installation BN/GBN/UBN

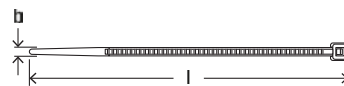
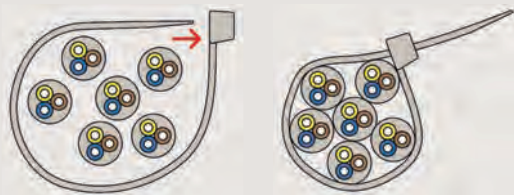

Technical data

Cable tie BN/GBN/UBN



BN colour transparent

UBN colour black

GBN colour green

8

Item	Colour: black	Colour: transparent	Colour: green	Dimensions [mm]	Sales unit	Outer carton
	Item No.	Item No.	Item No.		[pcs]	[pcs]
BN/UBN/GBN 2,5 x 100	087488	087478	543924	2,5 x 100	100	20000
BN/UBN 2,5 x 120	087489	087479	—	2,5 x 120	100	15000
GBN 2,5 x 150	—	—	543925	2,5 x 150	100	20000
BN/UBN/GBN 2,5 x 200	087490	087480	543926	2,5 x 200	100	10000
BN/UBN 2,5 x 160	069363	037489	—	2,5 x 160	100	20000
BN/UBN/GBN 3,6 x 150	087491	087481	543927	3,6 x 150	100	10000
BN/UBN 3,6 x 200	037573	019802	—	3,6 x 200	100	10000
BN/UBN 3,6 x 300	069364	037490	—	3,6 x 300	100	7500
BN/UBN 4,6 x 160	069365	037501	—	4,6 x 160	100	10000
BN/UBN 4,6 x 190	069366	037581	—	4,6 x 190	100	10000
BN/UBN/GBN 4,6 x 200	087494	087484	543928	4,6 x 200	100	7500
BN/UBN 4,8 x 250	069367	—	—	4,8 x 250	100	5000
BN/UBN 4,8 x 250	—	037582	—	4,8 x 250	100	5000
BN/UBN/GBN 4,8 x 280	087495	087485	543929	4,8 x 280	100	5000
BN/UBN 4,8 x 350	069368	037653	—	4,8 x 350	100	5000
BN/UBN 4,8 x 370	069369	037583	—	4,8 x 370	100	5000
BN/UBN 4,8 x 430	069370	037708	—	4,8 x 430	100	5000
BN/UBN 7,6 x 200	069372	037945	—	7,6 x 200	100	4500
BN/UBN 7,8 x 300	069373	037949	—	7,6 x 300	100	2500
BN/UBN 7,6 x 350	087497	087487	—	7,6 x 350	100	2500
BN/UBN 7,6 x 450	069374	037996	—	7,6 x 450	100	2500
BN/UBN 7,6 x 550	069375	037997	—	7,6 x 550	100	2000
BN/UBN 8,8 x 760	069376	037998	—	8,8 x 760	100	1000
BN/UBN 8,8 x 810	069377	038000	—	8,8 x 810	100	1000
BN/UBN 8,8 x 1168	069379	038002	—	8,8 x 1168	100	500

Cable tie plug FCTP

The universal fixing point for cable ties



Electric cables



Flexible and rigid plastic pipes

Applications

- Universal fixing point for fixing of cables and pipes using cable ties

Advantages

- The FCTP cable tie plug combines the function of a plug and an eyelet to which cable ties up to 9.5 mm width can be attached (e.g. fischer BN or UBN).
- It offers a universal fixing point to which various cables and pipes can be at-

Building materials

- Concrete
- Solid brick
- Solid sand-lime brick

Versions

- Nylon, halogen-free

tached.

- Installation is simple and time-saving by driving the plug into the drill hole.
- The lamellas of the plug ensure a secure hold in the building material and thus fix the cable tie in the intended position.

Functioning

- The cable tie plug can be hammer set.
- A cable tie is inserted through the eyelet and the object to be fastened is fixed in the intended position.
- The eyelet with a width of 9.5 mm and a height of 3 mm is suitable for all fischer cable ties.

Installation FTCP

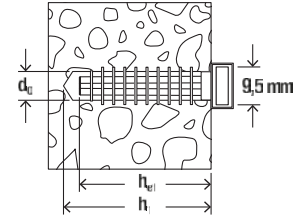
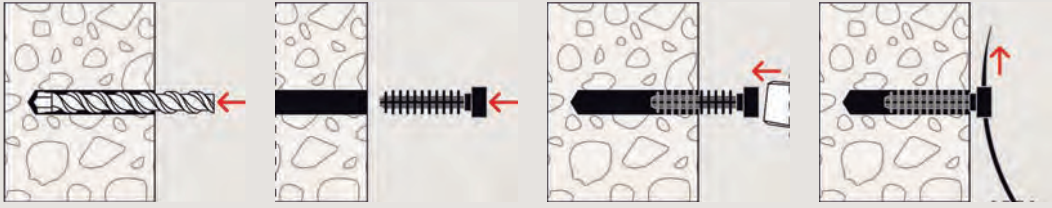

8

Technical data

Cable tie plug FCTP



FCTP-W

FCTP-B

Item	Item No.	Drill diameter d_0 [mm]	Min. drill hole depth h_1 [mm]	Anchorage depth h_{ef} [mm]	Total length l [mm]	Sales unit [pcs]
FCTP-W	545786	8	40	35	45	100
FCTP-B	545787	8	40	35	45	100

Wireclip WIC

Infinitely variable fixing of wire suspensions



Suspension of signs



Suspensions for trade show exhibits

Applications

For suspension of:

- Lighting strips
- Cable trays
- Ventilation ducts
- Pipes
- Signs
- Chilled ceilings

Advantages

- The simple system guarantees ease of use.
- The Wireclip's simple closing mechanism means that no tools are needed. This

allows for a cost-effective installation.

- The reclosable Wireclips make it possible to adjust the length at any time. This guarantees the greatest flexibility.

Functionality

- Loops are formed from the wire, which can be threaded through the wireclip. This allows objects to be hung. The wireclips can be adjusted at any time.
- The FNA II 6x25 OE is suitable for fixing the wire.

Note:

- Do not apply paint or any other coating.
- Do not apply lubricant.
- Do not use for lifting loads.
- Remove damaged wire ends using the wire cutter WIZ prior to introducing wires into the wire clip.

Installation WIC

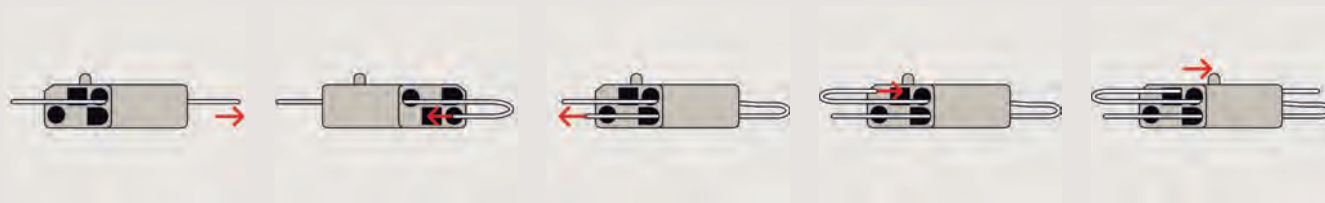

Technical data

Wireclip WIC



WIC 2



WIC 3



WIC 4

Item	Item No.	Wire-Ø [mm]	Sales unit [pcs]
WIC 4 VE50	044564	3 - 4	50
WIC 3 VE20	044561	2,5 - 3,5	20
WIC 2 VE100	044560	2 - 2,5	100
WIC 2 VE20	044559	2 - 2,5	20

Technical data

Wire cable with eye and wireclip WIS



WIS cable set with eyelet



WIZ

Item	Item No.	Cable length [m]	Wire-Ø [mm]	Sales unit [pcs]
WIS 2/1	045956	1	2	10
WIS 2/2	045957	2	2	10
WIS 2/3	045958	3	2	10
WIS 2/5	045959	5	2	10
WIS 2/10	045960	10	2	10
WI Ø 2 mm	044565 ¹⁾	200	2	1
WIZ	044721	—	—	1

¹⁾ on a roll

Loads

Wireclip

Recommended loads¹⁾ per Wireclip.

Type	Diameter of wire cable	Recommended tension load N_{rec}
	[mm]	[kN]
WIS complete system	2.0	0.5
WIC 2 ²⁾	2.0	0.6
WIC 2 ²⁾	2.5	1.0
WIC 3 ²⁾	3.0	1.2
WIC 4 ²⁾	4.0	2.3

¹⁾ Required safety factors are considered.





²⁾ Only in combination with fischer wire cable.



9

9

Sanitary fixings

Sanitary fixings for board materials	496	
Ceramic fixings	499	
Washbasin fixing WST Klik	502	
Wash basin and urinal fixings	504	

Sanitary fixings for board materials

Complete fixing sets for wash basins and urinals in board building materials and plumbing walls



Urinals

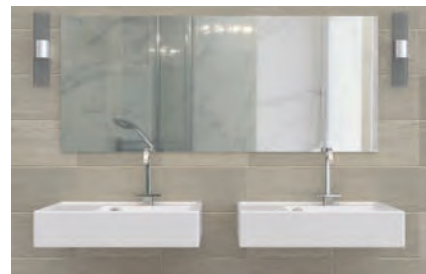

Wash basins

9

Applications

- Wash basins
- Urinals

Advantages

- With their special geometries, KM and WDP are the specialists for fixings in plumbing and hollow walls.
- The wide transition beams of the KM and

the large base plate of the WDP ensure a good load distribution, thus allowing for a high load-bearing capacity.

Building materials

- Gypsum plasterboard and gypsum fibreboards
- Chipboard

Functioning

- KM is suitable for push-through installation.
- When placed in the drill hole, the wide transition beam of the KM independently swings open behind the board.
- WDP is set into the plumbing walls during wall installation.

Installation WDP

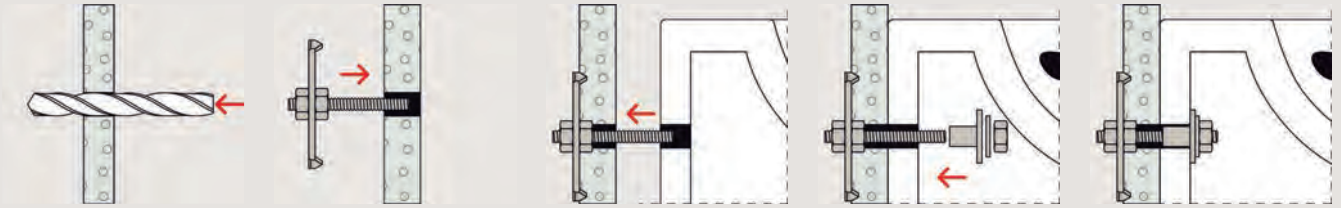

Installation KM

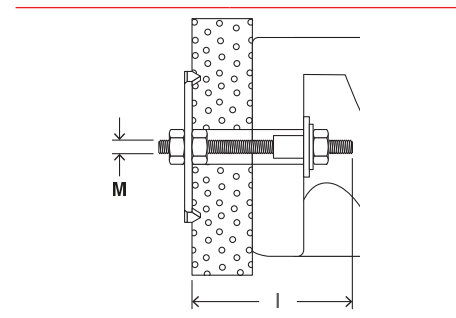
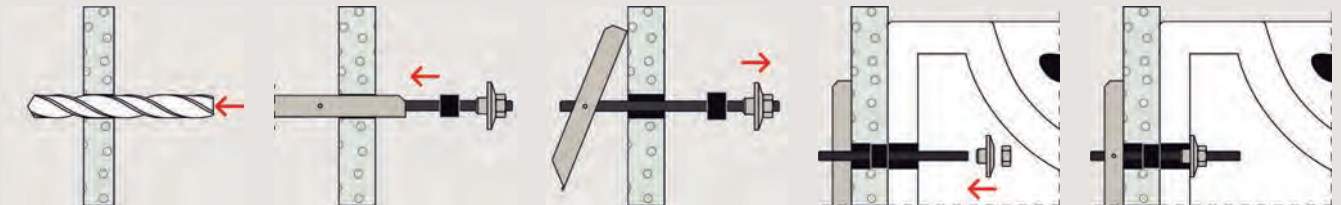

Technical data

Wash basin and urinal fixing WDP



WDP

Item	Item No.	Contents per plastic bag [pcs]	Sales unit [pcs]
WDP 10 x 170	014320	2 Threaded rods M10 x 170 with base plate 60x60x3, 2 flanged bushes BDH M10, 2 hexagon nuts M10 zinc-plated	10

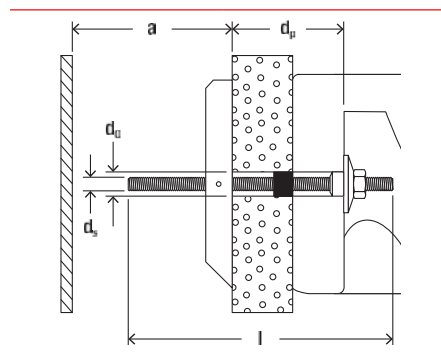

Technical data

Gravity toggle KM 10

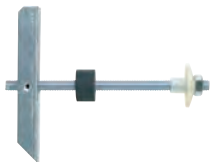

KM 10

Item	Item No.	Drill hole diameter d_0 [mm]	Anchor length l [mm]	Min. cavity depth a [mm]	Max. panel thickness d_p [mm]	Screw $d_s \times l_s$ [mm]	Sales unit [pcs]
KM 10	050326	30	180	140	90	M 10 x 180	25

Ceramic fixings

Complete fixing sets for free-standing toilets and bidets

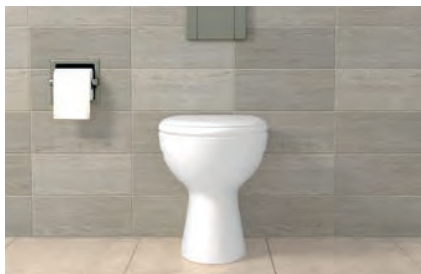

Free-standing toilets

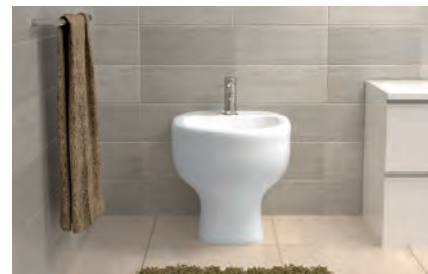

Bidets

Applications

- Free-standing toilets
- Bidets
- Ceramic shelves
- Mirrors

Characteristics



Advantages

- Complete fixing sets including brass screws allow for quick and easy installation.
- A pronounced rim prevents contact between the screw and ceramics, thus ensuring nothing gets damaged during

Building materials

- Concrete
- Solid sand-lime brick
- Natural stone with dense structure
- Solid brick made from lightweight concrete
- Solid brick

- fixing.
- The WB5N's assembly bracket with pre-drilled rows of holes allows for a flexible fixing with two directions.
- The WCN is also suitable for fixing ceramic shelves and mirrors, and can thus be used for a wide range of applications.

Functioning

- S 8 RD is suitable for push-through installation.
- WCN and S 8 D are suitable for both pre-positioned and push-through installation.
- The WB5N's assembly bracket is flexibly positioned on the base using the long hole. The ceramics are then fixed to the bracket via the rows of holes. These counterbalance any height differences in the ceramic assembly holes.

Installation WCN / S 8 D 70 WCR / S 8 RD WCR

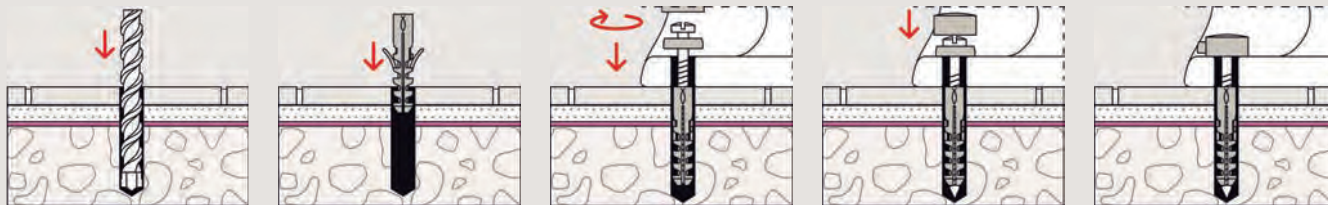

Installation WB 5N

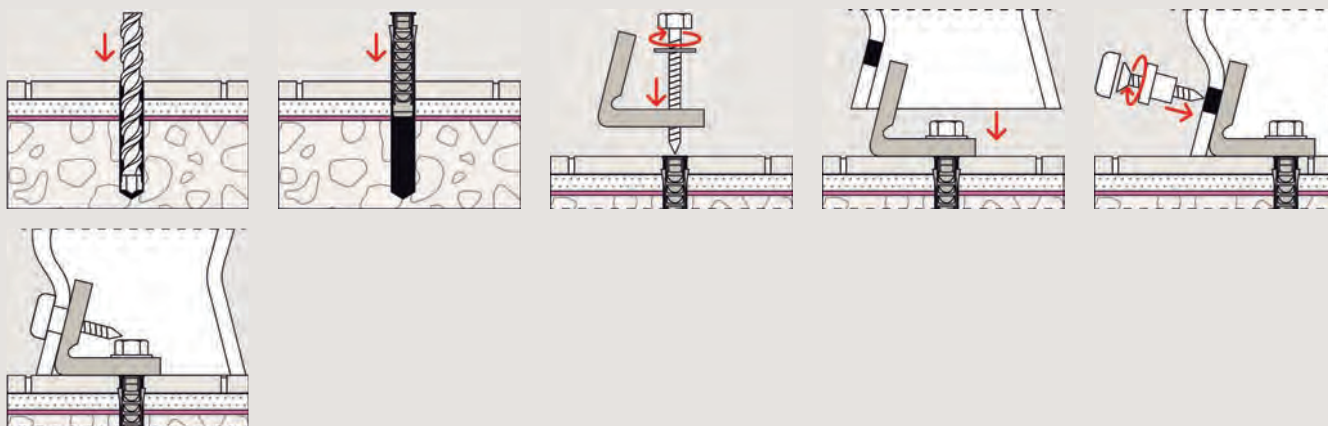

9

Technical data

Sanitary fixing set WCN



WCN

Item	Item No.	Contents per plastic bag [pcs]	Sales unit [pcs]
WCN 2	060562	2 wall plugs S 8, 2 stainless steel screws 6 x 70 hex., 2 cover caps chrome, 2 snap-fit sleeves	50
WCN 1	060561	2 wall plugs S 8, 2 stainless steel screws 6 x 70 hex., 2 cover caps white, 2 snap-fit sleeves	50

Technical data

Sanitary fixing set S 8 D 70 WCR



S 8 D 70 WCR

Item	Item No.	Contents per plastic bag [pcs]	Sales unit [pcs]
S 8 D 70 WCR	060564	2 wall plugs S 8, 2 stainless steel screws 6 x 70 hex., 2 cover caps chrome and white, 2 snap-fit sleeves	50

Technical data

Sanitary fixing set S 8 RD WCR



S 8 RD WCR

Item	Item No.	Contents per plastic bag [pcs]	Sales unit [pcs]
S 8 RD 60 WCR	060570	2 wall plugs S 8 RD 60, 2 stainless steel screws 6 x 65 hex., 2 cover caps chrome and white	50
S 8 RD 80 WCR	060568	2 wall plugs S 8 RD 80, 2 stainless steel screws 6 x 85 hex., 2 cover caps chrome and white	50

Technical data

WC fixing WB 5N



WB 5N

Item	Item No.	Contents	Sales unit [pcs]
WB 5N	018652	2 S plugs SX 10, 2 Screws 7x65 zinc-plated, 2 Nylon angles, 2 washers 8mm, 2 screws A2 stainless steel, 2 flanged sleeves, 2 cover caps chrom	50

Washbasin fixing WST Klik

For the safe one-man installation of washbasins

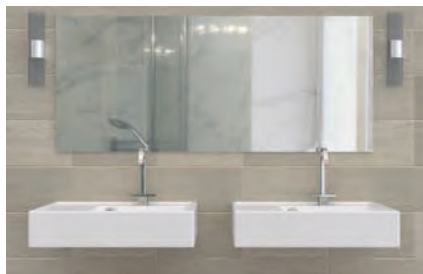

Fixing of washbasins

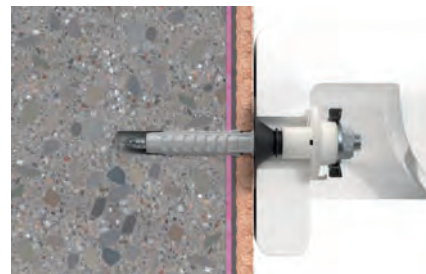

WST Klik with SX plug in concrete

9

Applications

- Wall-mounted washbasins

Advantages

- The complete mounting set including the fixing sleeve enables safe and quick mounting. The “click” sound confirms correct mounting.
- By engaging the two sleeves, the washbasin can no longer tilt forward, enabling easy one-man assembly.
- By turning the black sleeve, the washbasin can be optimally aligned and adjusted afterwards.
- The aging- and chemical-resistant fixing

- sleeve made of consistent plastic guarantees permanently secure fastening.
- The enclosed fischer SX plug enables installation in many building materials such as concrete, aerated concrete and masonry made of solid or perforated construction material.
- By opening the black fixing clips, the washbasin can be easily disassembled.

Characteristics



Building materials

- Concrete
- Solid brick
- Solid sand-lime brick
- Aerated concrete
- Vertically perforated brick
- Perforated sand-lime brick

Functioning

- The expansion plug SX is suitable for push-in and push-through installation. When screwing in the screw, the SX expands in four directions and thus securely fixes into the building material.
- The single parts of the fixing sleeve are mounted in advance in the opening of the ceramic back panel and plugged into each other.
- The washbasin is then slipped over the pre-assembled stud screw and pushed onto the wall.
- After the fixing sleeve has engaged, the washbasin no longer tilts forward. This allows the washbasin to be optimally aligned and then fixed with the nut.
- The maximum load capacity is only achieved when the minimum screw-in depth is reached. Tiles and plaster are considered as non-load-bearing substrates.

Installation WST Klik

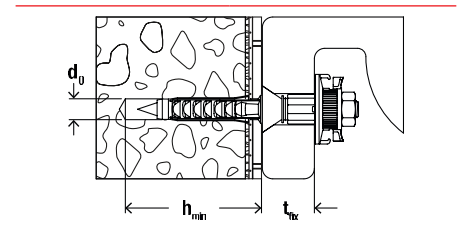
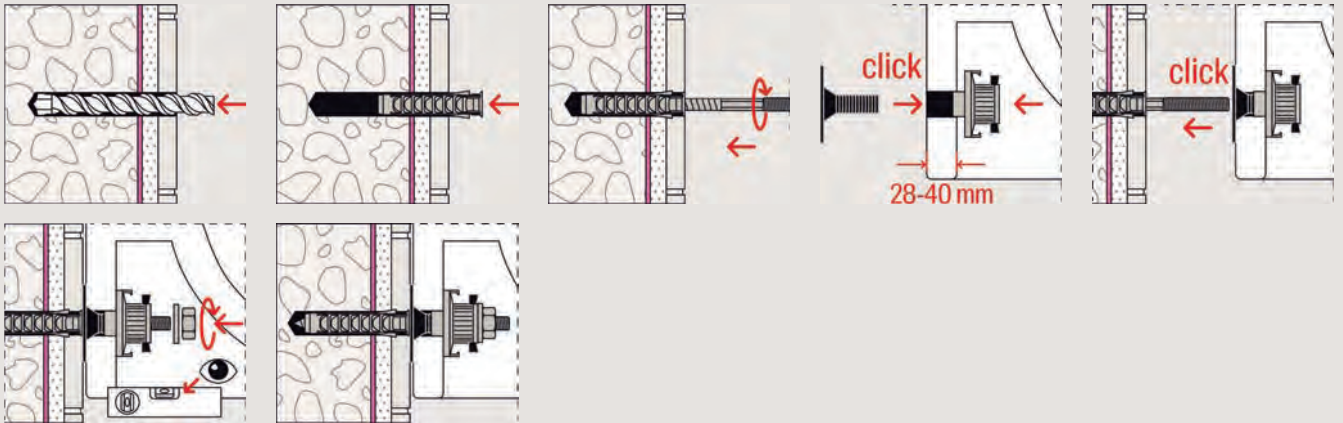

Technical data

Washbasin fixing WST Klik in combination with expansion plug SX



WST Klik

Item	Item No.	Drill hole diameter d_0 [mm]	Min. drill hole depth h_1 [mm]	Anchor length l [mm]	Screw \emptyset x length	Fixture thickness t_{fix} [mm]	Sales unit [pcs]
WST Klik 120	541479	12	80	60	M 10 x 127	28 - 40	1
WST Klik 140	541480	14	90	70	M 10 x 140	28 - 40	1

Loads

Washbasin fixing WST Klik in combination with expansion plug SX

Recommended loads^{1) 2)} for a single anchor.

Type		WST 120 Klik	WST 140 Klik
Expansion plug SX	[mm]	12 x 60	14 x 70
Recommended load in the respective base material F_{rec}			
Concrete	\geq C20/25	[kN] 1.70	1.90
Vertically perforated brick	\geq Hlz 12	[kN] 0.26	0.50
Solid brick	\geq Mz 12	[kN] 0.70	1.90
Solid sand-lime brick	\geq KS 12	[kN] 1.70	1.90
Aerated concrete	\geq AAC 2	[kN] 0.14	0.29
Aerated concrete	\geq AAC 4	[kN] 0.45	0.73

¹⁾ Required safety factors are considered. Load values are valid for using the supplied plug and the stud screws with the specified diameter.

²⁾ Valid for tensile load, shear load and oblique load under any angle.

Wash basin and urinal fixings

Complete fixing sets for wash basins, urinals and sanitary installations



Urinals



Wash basins

9

Applications

- Wash basins
- Urinals
- Built-in toilets
- Boilers
- Gas heaters
- Cisterns
- Consoles

Characteristics



Advantages

- Complete fixing sets allow for quick and easy installation.
- The universal plug UX can be used in solid and hollow materials, thus offering a high level of flexibility.
- Flanged nuts and collar sleeves made of high-strength nylon are resistant to

Building materials

- Concrete
- Vertically perforated brick
- Hollow blocks made from lightweight concrete
- Perforated sand-lime brick
- Solid sand-lime brick
- Natural stone
- Aerated concrete
- Solid panel made from gypsum
- Solid brick made from lightweight concrete
- Solid brick

ageing and chemicals, and guarantee a long-lasting fixing that will not damage the ceramics.

- Cover caps with a high-quality chrome finish ensure the fixture remains visually attractive for a long period of time.

Functioning

- The rimless UX is suitable for pre-positioned and push-through installation.
- Screwing in the screw causes the UX to expand in solid and hollow building material.
- Maximum load-bearing capacity is only achieved when the minimum screw-in depth is reached.
- Tiles and plaster are not classed as load-bearing base materials.

Installation WD/BO/WST/UST

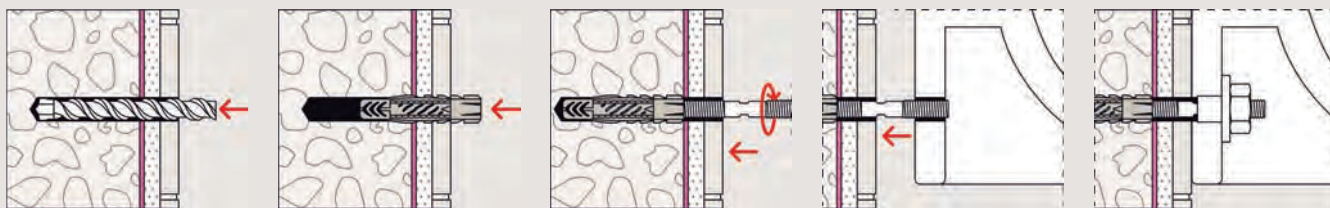

Technical data

Wash basin and urinal fixing WD



WD

Item	Item No.	Contents per plastic bag [pcs]	Sales unit [pcs]
WD 8 x 90	080659	2 wall plugs UX 10 x 60, 2 stud screws M8 x 90 zinc-plated, 2 flanged nuts BU M8	50
WD 8 x 110	080658	2 wall plugs UX 10 x 60, 2 stud screws M8 x 110 zinc-plated, 2 flanged nuts BU M8	50
WD 10 x 120	080655	2 wall plugs UX 14 x 75, 2 stud screws M10 x 120 zinc-plated, 2 flanged nuts BU M10 MH	50
WD 10 x 140	080656	2 wall plugs UX 14 x 75, 2 stud screws M10 x 140 zinc-plated, 2 flanged nuts BU M10 MH	50

9

Technical data

Boiler fixing BO



BO

Item	Item No.	Contents per plastic bag [pcs]	Sales unit [pcs]
BO 120	080654	4 wall plugs UX 14 x 75, 4 stud screws M10 x 120 zinc-plated, 4 flanged nuts BU M10	25

Technical data

Wash basin fixing WST



WST

Item	Item No.	Contents per plastic bag [pcs]	Sales unit [pcs]
WST 10 x 140	080660	2 wall plugs UX 14 x 75, 2 stud screws M10 x 140 zinc-plated, 2 hexagon nuts M10 zinc-plated, 2 flanged bushes BDH M10	50
WST 12 x 150	080661	2 wall plugs UX 14 x 75, 2 stud screws M12 x 150 zinc-plated, 2 hexagon nuts M12 zinc-plated, 2 flanged bushes BDH M12	50
WST 12 x 180	080662	2 wall plugs UX 14 x 75, 2 stud screws M12 x 180 zinc-plated, 2 hexagon nuts M12 zinc-plated, 2 flanged bushes BDH M12	50

Technical data

Urinal fixing UST



UST 8 x 110

UST 10 x 120

Item	Item No.	Contents per plastic bag [pcs]	Sales unit [pcs]
UST 8 x 110	083578	2 wall plugs UX 10 x 60, 2 stud screws M8 x 110, 2 washers B 8.4 DIN 125, 2 plastic washer 8,4 x 16 x 1,6, 2 cap nuts FA 8, 2 cover caps chrome plated	50
UST 10 x 120	080668	2 wall plugs UX 14 x 75, 2 stud screws M10 x 120, 2 flanged nuts BU M10, 2 cover caps AKM 10 CR	10

Technical data

WC and sanitary fixing WL



WL

Item	Item No.	Contents per plastic bag [pcs]	Sales unit [pcs]
WL 7 x 60	080651	2 plugs S 10, 2 screws 7 x 65 hex. head zinc-plated, 2 washers zinc-plated	100
WL 8 x 70	080652	2 plugs S 10, 2 screws 8 x 70 hex. DIN 571 zinc-plated, 2 washers zinc-plated	100
WL 10 x 80	080650	2 plugs S 12, 2 screws 10 x 80 hex. DIN 571 zinc-plated, 2 washers zinc-plated	50

Accessories

Flanged nut BU M



BU M

Item	Item No.	Thread M	Width across nut SW [mm]	Washer [mm]	Match	Sales unit [pcs]
BU M8 MH	060200 ¹⁾	M 8	17	40	STS M8	25
BU M10 MH	060201	M 10	17	40	STS M10	25
BU M12 MH	060204	M 12	19	40	STS M12	25

1) Delivery time on request.

Accessories

Cover cap AKM



AKM

Item	Item No.	Colour	Match	Sales unit [pcs]
AKM 10 W	080972	white	BU M10 MH	20
AKM 10 CR	080951	chrome	BU M10 MH	100
AKM 12 CR	080952	chrome	BU M12 MH	100







10

508

10

Scaffold and eye screw fixings

Scaffold anchoring GS 12 + plug	510	
Scaffold anchoring FI G	513	
Eye screw GS	515	
Ring nut RI	518	

Scaffold anchoring GS 12 + plug

The standard scaffold anchoring



Scaffold anchoring



Façade scaffolds

Applications

- Façade scaffolds
- Ropes
- Chains
- Trellises
- Lighting
- Clothes lines
- Hanging baskets

Advantages

- The ideal interaction of the scaffold eye-bolt and plug allows for a high load-bearing capacity, thus providing increased safety.
- The high-quality weld stops the eye from opening.

- The large diameter of the cover caps (available separately) covers drill holes completely and discreetly, even those with slightly broken edges.

Certificates



Building materials

GS 12 + S 14 ROE suitable for:

- Concrete
- Solid sand-lime brick
- Natural stone with dense structure
- Solid brick
- Solid brick made from lightweight concrete

GS 12 + S 16 H R suitable for:

- Vertically perforated brick
- Perforated sand-lime brick
- Aerated concrete

Functioning

- In order to achieve the maximum load-bearing capacity, nylon plugs should only be used once.
- The combination with plug S 16 H R is recommended for perforated brick and aerated concrete.
- The screw-in markings provide a visual control during assembly, and thus allow for a simple and problem-free installation.
- Pre-drill into wood when not using plugs. The drill bit diameter should equal the core diameter of the screw.
- Suitable cover caps AD 12x40 (see page 514) for closing off remaining drill holes for S 14 ROE.
- Not suitable for swings, hammocks etc.

Installation GS 12

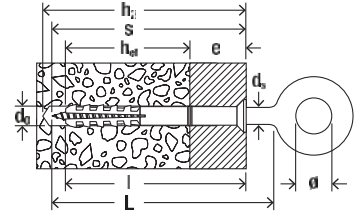
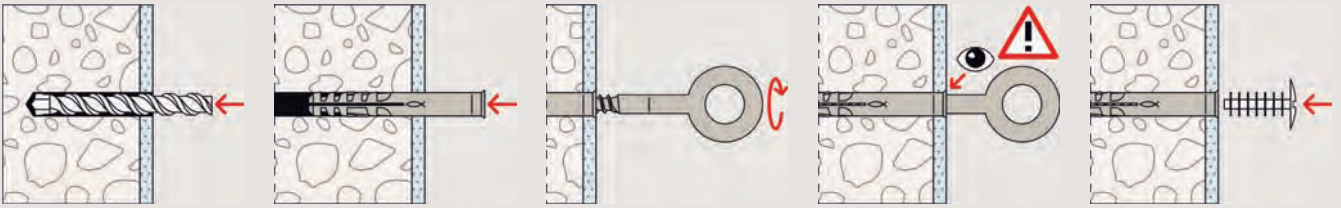

Technical data

Eye screw GS



GS 12

Item	Item No.	Shaft diameter	Shaft length	Max. thickness of non-bearing layer	Eye-Ø	Match	Sales unit
		d_s [mm]	L [mm]	e [mm]	[mm]		[pcs]
GS 12 x 90	080925	12	90	15	23	S 14 ROE 70	25
GS 12 x 120	080926	12	120	30 / 10	23	S 14 ROE 100 / S 16 H 100 R	25
GS 12 x 160	080927	12	160	65 / 45	23	S 14 ROE 135 / S 16 H 135 R	25
GS 12 x 190	080960	12	190	110 / 70	23	S 14 ROE 185 / S 16 H 160 R	25
GS 12 x 230	080961	12	230	110 / 70	23	S 14 ROE 185 / S 16 H 160 R	25
GS 12 x 300	081269	12	300	110 / 70	23	S 14 ROE 185 / S 16 H 160 R	25
GS 12 x 350	080962	12	350	110 / 70	23	S 14 ROE 185 / S 16 H 160 R	25

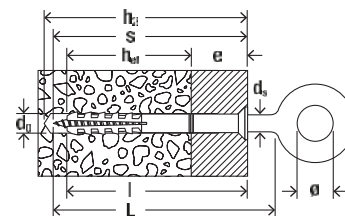

Technical data

Plug S 14 ROE / S 16 H R



S 14 ROE

S 16 H R

Item	Item No.	Drill hole diameter d_0 [mm]	Min. drill hole depth for through fixings h_2 [mm]	Effect. anchorage depth h_{ef} [mm]	Anchor length l [mm]	Max. thickness of non-bearing layer e [mm]	Min. bolt penetration $l + 5$ [mm]	Sales unit [pcs]
S 14 ROE 70	052160	14	95	70	70	—	75	25
S 14 ROE 100	052161	14	125	70	100	30	105	25
S 14 ROE 135	052162	14	165	70	135	65	140	25
S 14 ROE 185	052164	14	195	70	185	115	190	25
S 16 H 100 R	059187 ¹⁾	16	125	90	100	10	105	50
S 16 H 135 R	059188 ¹⁾	16	165	90	135	45	140	50
S 16 H 160 R	059189 ¹⁾	16	195	90	160	70	165	50

¹⁾ Also suitable for screws with metric thread M12.

Loads

Scaffold anchoring S 14 ROE / S 16 H R + GS 12

Mean ultimate loads¹⁾ for tension of a single anchor.

Type			S 14 ROE + GS 12	S 16 H R + GS 12
Mean ultimate loads for tension in the respective base material N_u				
Concrete	$\geq C20/25$	[kN]	14.5	-
Solid brick	$\geq Mz 12$	[kN]	13.0	-
Solid sand-lime brick	$\geq KS 12$	[kN]	14.5	-
Solid brick of lightweight aggregate concrete	$\geq V 2$	[kN]	3.0	-
Perforated sand-lime brick	$\geq KSL 12$	[kN]	-	5.0
Vertically perforated brick	$\geq Hlz 12$	[kN]	-	3.5
Aerated concrete	$\geq AAC 4$	[kN]	3.0	3.0

¹⁾ On these values an appropriate safety factor has to be considered.

Scaffold anchoring FI G

The scaffold anchoring with metric thread M 12



Scaffold anchoring

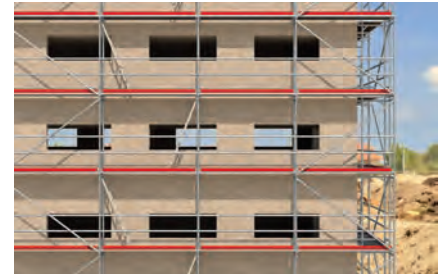

Façade scaffolds

Applications

- Façade scaffolds
- Trellises
- Tensioning ropes
- Chains
- Lighting
- Clothes lines
- Hanging baskets

Advantages

- When used together with an internal threaded anchor or a steel fixture with internal thread M 12, the scaffold screw FI G allows for repeated installation and removal using the same fixing point.

- The high-quality weld stops the eye from opening, thus providing increased safety.

10

Building materials

When combined with internal threaded anchor:

- Concrete C20/25 - C50/60:
Injection mortar FIS EM Plus / FIS V
Internal threaded anchor
RG 18x125 M12 I, Art.-No. 50562
ZYKON undercut anchor FZA-I
FZA 22x100 M12 I, Art.-No. 060763
- Masonry:
Injection mortar FIS V 360 S
Perforated sleeve FIS H 20x85 K, Art.-No. 41904
Internal threaded anchor
FIS E 15x85 M12, Art.-No. 43634

Functioning

- The scaffold anchoring FI G should be used with an internal threaded anchor. Detailed information about its functioning can be found in the "Chemical fixings" chapter.
- Not suitable for swings, hammocks etc.

Installation FI G

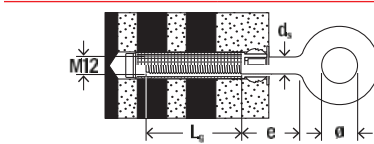
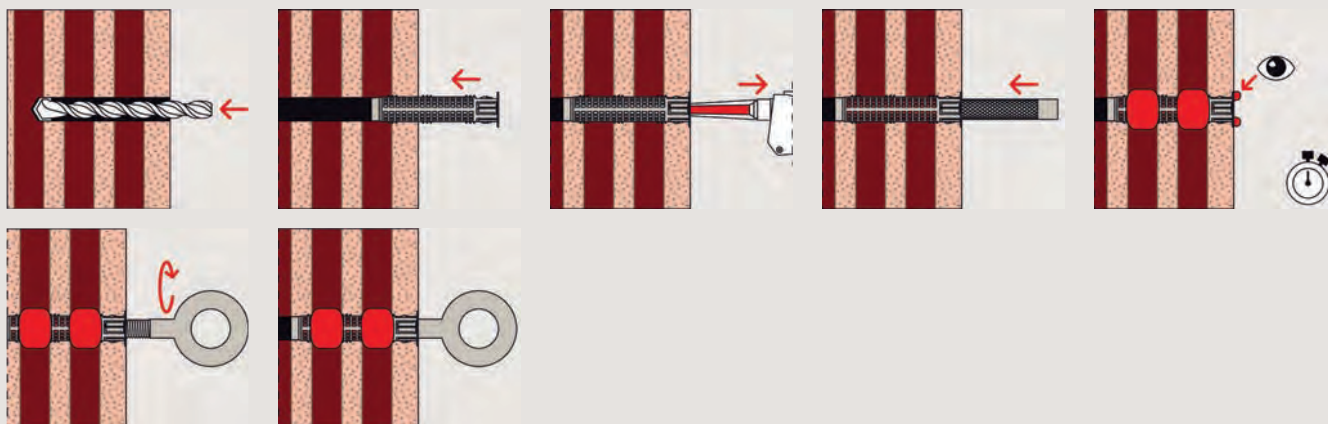

10

Technical data

Scaffold eyebolt FI G 12



FI G 12

Item	Item No.	Thread	Thread length	Shaft diameter	Max. thickness of non-bearing layer	Eye-Ø	Sales unit
		M	L_G [mm]	d_s [mm]	e [mm]	[mm]	[pcs]
FI G 12 x 40	080933	M 12	30	12	35	23	20
FI G 12 x 80	080934	M 12	30	12	75	23	20

Anchorage depth in the substrate is defined by the fixing used.

Accessories

Cover cap AD



AD 12 x 40

Item	Item No.	Colour	Length	Head height	Match	Sales unit
			L [mm]	[mm]		[pcs]
AD 12 x 40 W	060259	white	40	3	Plug-Ø 14 mm	100
AD 12 x 40 G	060260	grey	40	3	Plug-Ø 14 mm	100

Eye screw GS

The universal eye screw for use with fischer plugs or for direct use in wood



Hanging baskets



Trellis

Applications

- Ropes
- Chains
- Trellises
- Lighting
- Clothes lines
- Hanging baskets

Certificates



Advantages

- The ideal interaction of the eye screw and plug allows for a high load-bearing capacity, thus providing increased safety.

- The high-quality weld stops the eye from opening.

10

Building materials

GS 8 + SX 10 or GS 10 + SX 12 suitable for:

- Concrete
- Solid brick
- Perforated brick
- Aerated concrete

GS 10 + S 12 R suitable for:

- Concrete
- Solid brick

GS 10 + S 14 H R suitable for:

- Perforated brick

GS 8 or GS 10 without plug suitable for:

- Wood

Functioning

- Pre-drill when using with wood. The drill bit diameter should equal the core diameter of the screw.
- The maximum load-bearing capacity is achieved when combined with the plugs recommended by fischer (see table "Technical Data"). The nylon plug must only be used once.
- Not suitable for swings, hammocks etc.

Installation GS

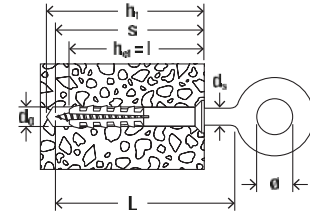
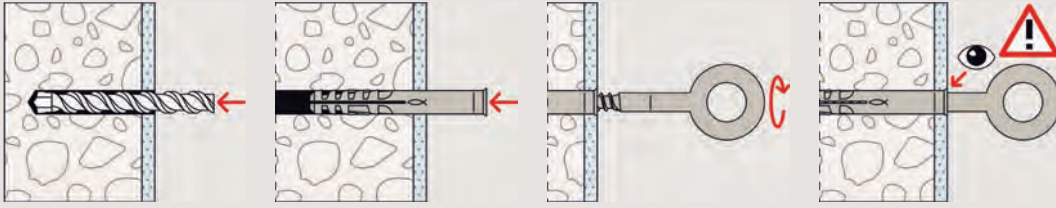

Technical data

Eye screw GS



GS

Item	Item No.	Shaft diameter d_s [mm]	Shaft length L [mm]	Bolt penetration s [mm]	Match	Eye-Ø [mm]	Sales unit [pcs]
GS 8 x 50 Ø15	502620	8	50	50	SX 10	15	20
GS 8 x 80 Ø22	080918	8	80	58	SX 10	22	20
GS 8 x 100 Ø22	080919	8	100	58	SX 10	22	20
GS 8 x 120 Ø22	080920	8	120	58	SX 10	22	20
GS 10 x 160 Ø30	080929	10	160	—	S 12 R, S 14 H R, SX 12	30	20

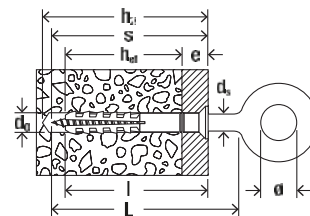

Technical data

Plug S 12 R / S 14 H R



S 12 R

S 14 H R

Item	Item No.	Drill hole diameter d_0 [mm]	Min. drill hole depth for through fixings h_2 [mm]	Bolt penetration s [mm]	Effect. anchorage depth h_{ef} [mm]	Anchor length l [mm]	Max. thickness of non-bearing layer e [mm]	Sales unit [pcs]
S 12 R 100	050177	12	120	110	60	100	40	100
S 12 R 135	050178	12	155	145	60	135	75	100
S 14 H 100 R	059179	14	120	110	90	100	10	50
S 14 H 135 R	059180	14	155	145	90	135	45	50

Loads

Eye screw GS

Recommended tensile loads¹⁾ for a single anchor.

The given loads are valid for the eye screw GS with the specified fischer plugs.

Type			SX 10x50 + GS 8	SX 12 + GS 10	S 12 R + GS 10	S 14 H R + GS 10
Recommended tensile loads in the respective base material N_{rec}						
Concrete	≥ C12/15	[kN]	1.20	1.70	1.03	-
Solid brick	≥ Mz 12	[kN]	0.65	0.70	1.00	-
Solid sand-lime brick	≥ KS 12	[kN]	1.20	1.70	0.84	-
Solid brick of lightweight aggregate concrete	≥ V 4	[kN]	-	-	0.29	0.43
Perforated sand-lime brick	≥ KSL 12	[kN]	0.35	0.35	0.30	0.34
Vertically perforated brick	≥ Hlz 12 ($\rho \geq 1 \text{ kg/dm}^3$)	[kN]	-	-	0.36	0.50
Aerated concrete	≥ AAC 2 (G2)	[kN]	0.09	0.20	-	-
Aerated concrete	≥ AAC 4 (G4)	[kN]	0.30	0.60	-	-

¹⁾ Required safety factors are considered.

Ring nut RI

The ring nut for all fixings with threaded studs



Transmission of loads

Applications

- Ropes
- Chains
- Trellises
- Lighting
- Clothes lines
- Hanging baskets

Advantages

- The metric internal thread gives the ring nut RI flexibility and means it can be used with a range of steel anchors or thread-

ed rods; e.g. FH II, FHB II-A, RG M, FZA, FAZ II, FIS A.

Building materials

- In line with the anchor used:
- Concrete, cracked and non-cracked
 - Solid and perforated brick

Functioning

- The ring nut is to be used with an anchor with threaded studs.
Detailed information about its functioning can be found in the “High performance steel anchors” and “Chemical fixings” chapters. The following anchors, for example, can be used: FHB II, RG M, FZA, FAZ II, FIS A.
- Not suitable for swings, hammocks etc.

Installation RI



Technical data

Ring nut RI



RI

Item	Item No.	Match	Eye-Ø [mm]	Total height [mm]	Sales unit [pcs]
RI M 8	080840	M 8	20	36	20
RI M 10	080842	M 10	25	45	10
RI M 12	080844	M 12	30	53	10

10

Loads

Ring nut RI

Recommended loads¹⁾ for ring nuts.

The given loads apply for the use of ring nuts as permanent anchorage. For varying use of different components to be lifted ring nuts with next larger thread diameter has to be use (see DIN 582).















Type		RI M 8	RI M 10	RI M 12
Thread size		M 8	M 10	M 12
Recommended load per ring nut for respective set-up F_{rec}				
Axial tension on single ring nut		[kN] 1.40	2.30	3.40
Axial or oblique tension up to 45° on a group of two ring nuts		[kN] 1.00	1.70	2.40
Shear or oblique tension up to 45° on a group of two ring nuts for lateral arrangement		[kN] 0.70	1.15	1.70

¹⁾ Required safety factors are considered.



11

Insulation fixings/ Façade fixings

Insulation support DHK	522	
Insulation support DHM	524	
Render fixing DIPK	527	
Render fixing FIF-PN 8	529	
Render fixing FIF-CN II 8	532	
Render fixing FIF-CS 8	535	
Insulation discs DT	538	
Insulation discs	539	
TermoFix H	541	
Retaining disc with screw DHT S	542	
Insulation fixing FID	544	
Insulation fixing FID-R	546	
Insulation fixing FID GREEN	548	
Holding clamp DVN	550	

Insulation support DHK

The cost-effective plastic insulation support for all conventional insulating boards



Insulating materials in rear-ventilated façades



Insulating materials in rear-ventilated façades

Applications

To fix soft and pressure-resistant insulating materials in rear-ventilated façades, such as:

- Mineral / glass wool
- PU panels
- Light building boards made of wood wool
- Cork boards / coir matting
- Polystyrene
- Foam glass tiles

Advantages

- The optimised geometry of the expansion section ensures a low anchorage depth and reduces the amount of drilling required.
- Flexible pins in the plate area adapt to the insulating material, and ensure a sustained contact pressure.
- The simpleammerset installation allows

for a quick installation process and thus reduces workload.

- The colouring of the DHK means that it does not stand out on black clad insulating material in rear-ventilated façades.
- The DHK 45 is suitable for use in pressure-resistant insulating boards and reveals.

Building materials

- Concrete
- Hollow blocks made from lightweight concrete
- Vertically perforated brick
- Perforated sand-lime brick
- Solid sand-lime brick
- Natural stone with dense structure
- Aerated concrete
- Solid brick made from lightweight concrete
- Solid brick

Functioning

- The DHK is set in push-through installation using a hammer.
- The plate size of the insulation support is to be selected in line with the compressive strength of the insulating material: DHK 45 for pressure-resistant; DHK 90 for soft insulating materials.
- The expansion of the ribs in the drill hole gives the DHK an ideal contact pressure.
- Temperature range when installed: -40 °C to +80 °C.

Installation DHK

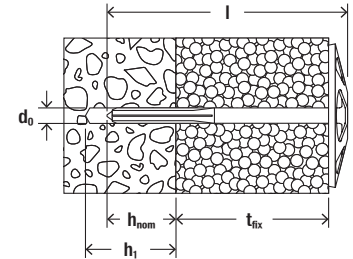
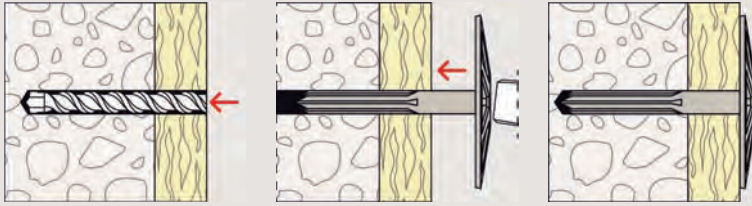

Technical data

Insulation support DHK

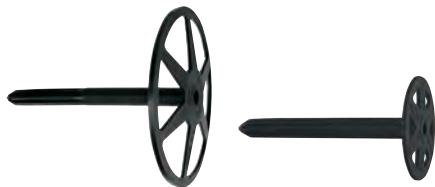
 DHK, plate- \varnothing 90 mm

 DHK 45, plate- \varnothing 45 mm

Item	Item No.	Drill hole diameter d_0 [mm]	Min. drill hole depth h_1 [mm]	Effect. anchorage depth h_{ef} [mm]	Anchor length l [mm]	Max. fixture thickness t_{fix} [mm]	Sales unit [pcs]
DHK 40	080937	8	30	20	65	40	250
DHK 60	080938	8	30	20	85	60	250
DHK 80	080939	8	30	20	105	80	250
DHK 100	080940	8	30	20	125	100	250
DHK 120	080941	8	30	20	145	120	200
DHK 140	080949	8	30	20	165	140	200
DHK 160	512150	8	30	20	185	160	100
DHK 180	512151	8	30	20	205	180	100
DHK 200	512153	8	30	20	225	200	100
DHK 220	512154	8	30	20	245	220	100
DHK 45/40	080892	8	30	20	65	40	250
DHK 45/60	080893	8	30	20	85	60	250
DHK 45/80	080894	8	30	20	105	80	250
DHK 45/100	080895	8	30	20	125	100	250

Loads

Insulation support DHK

Recommended loads¹⁾ for a single anchor.

Type		DKH
Recommended loads in the respective base material $F_{rec}^{2)}$		
Concrete	$\geq C12/15$	[kN] 0.03
Solid brick	Mz 12	[kN] 0.03
Solid sand-lime brick	KS 12	[kN] 0.03
Perforated sand-lime brick	KSL 6	[kN] 0.03
Vertically perforated brick	Hlz 12	[kN] 0.02
Aerated concrete	$\geq AAC 2 (G2)$	[kN] 0.02

¹⁾ Required safety factors are considered.

²⁾ Valid for tensile load.

Insulation support DHM

The fire-protection-tested metal insulation support for fire-resistant insulating boards



Pressure-resistant insulating materials on ceiling undersides



Pressure-resistant insulating materials in curtain façades

Applications

To fix fire-resistant soft or pressure-resistant insulating materials, such as:

- Mineral / glass wool
- Light building boards made of wood wool
- Foam glass tiles

Also suitable for:

- Polystyrene boards
- Coir matting

Advantages

- The metal insulation support achieves fire resistance F 120. This means that it can be used where there are fire resistance requirements.
- The DTM 80 plate for soft insulating materials (available separately) simplifies storage and minimises costs.
- The simpleammerset installation allows

for a quick installation process and thus reduces workload.

- The shaft geometry allows setting in aerated concrete without pre-drilling, thus saving a stage of installation.
- Stainless steel version DHM A2 (1.4301) for wet and exterior applications.

Certificates



Fire resistance classification
R120

Building materials

- Concrete
- Hollow blocks made from lightweight concrete
- Vertically perforated brick
- Perforated sand-lime brick
- Solid sand-lime brick
- Natural stone with dense structure
- Aerated concrete
- Solid brick made from lightweight concrete
- Solid brick

Functioning

- The insulation support is set in push-through installation using a hammer.
- When hammered in, the expansion part tightens like a spring with the substrate.
- Use the DTM 80 plate (available separately) to fix soft insulating materials.

Installation DHM

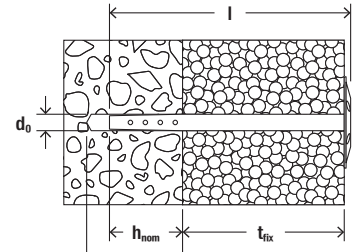
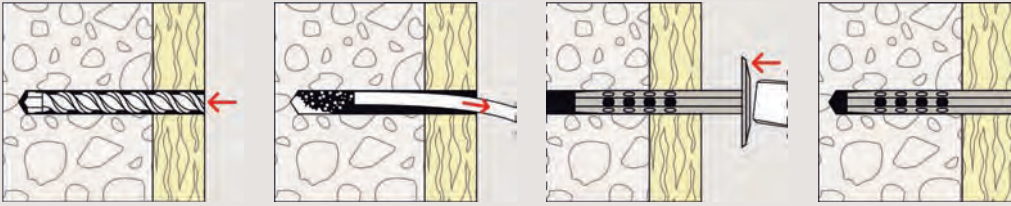

Technical data

Insulation support DHM

 DHM, washer- \varnothing 35 mm

 DTM 80, washer- \varnothing 80 mm,
inside- \varnothing 11 mm

Item	Hot-dip galvanised steel	Stainless steel A2	Approval	Drill hole diameter	Min. drill hole depth	Effect. anchor- age depth	Anchor length	Usable length	Sales unit
	Item No.	Item No.		d_0 [mm]	h_1 [mm]	h_{ef} [mm]	l [mm]	t_{fix} [mm]	[pcs]
	hdg	A2	DIBt						
DHM 40	536253	536262	●	8	50	40	80	10 - 40	250
DHM 70	536254	536264	●	8	50	40	110	40 - 70	250
DHM 100	536256	536265	●	8	50	40	140	70 - 100	250
DHM 130	536257	536266	●	8	50	40	170	100 - 130	250
DHM 160	536258	536267	●	8	50	40	200	130 - 160	250
DHM 210	536259	536268	●	8	50	40	250	170 - 210	125
DHM 260	536260	536269	●	8	50	40	300	220 - 260	125
DTM 80	536261	536271	●	—	—	—	—	—	250

Technical data

Cover cap DHM ADK



DHM ADK-W



DHM ADK-GR



DHM ADK-BG

Item	Item No.	Diameter	Colour	Sales unit
		[mm]		[pcs]
DHM ADK-W	013330	37	white	250
DHM ADK-GR	046843	37	grey	250
DHM ADK-BG	046844	37	beige	250

Loads

Insulation support DHM			
Recommended loads ¹⁾ for a single anchor.			
Type			DHM
Recommended loads in the respective base material $F_{rec}^{2)}$			
Concrete ³⁾	≥ C12/15	[kN]	0.25
Solid brick	Mz 12	[kN]	0.25
Solid sand-lime brick	KS 12	[kN]	0.25
Aerated concrete (without pre-drilling)	≥ AAC 2 (G2)	[kN]	0.10

¹⁾ Required safety factors are considered.

²⁾ Valid for tensile load.

³⁾ Acc. to German approval in cracked concrete ≥ C20/25 0.07 kN. The complete approval has to be considered.

Render fixing DIPK

The cost-effective hammerset anchor with plastic nail



Pressure-resistant insulation boards with rendering

Applications

To fix pressure-resistant insulating materials in façades, such as:

- Polystyrene boards
- Light building boards made of wood wool
- Cork boards / coir matting
- PU panels

Advantages

- The glass-fibre-reinforced plastic nail (GRP nail) reduces the heat transmission and prevents marks on the plaster surface.
- The simple hammerset installation allows for a quick installation process and thus reduces workload.
- The well-proven design with low anchor-

age depth reduces the amount of drilling required, thus achieving a high level of efficiency.

- The DIPK can be used universally in rear-ventilated curtain façades, as well as in plaster façades.
- The surface of the anchor plate is suitable to use as a plaster base

Building materials

- Concrete
- Hollow blocks made from lightweight concrete
- Vertically perforated brick
- Perforated sand-lime brick
- Solid sand-lime brick
- Natural stone with dense structure
- Solid brick

Functioning

- Non-bearing layers, such as adhesive and/or old render, are to be included in the anchor's useful length.
- The DIPK is set in push-through installation using a hammer.
- In solid materials the GRP nail needs to be shortened at the predetermined breaking point.
- Driving the nail into the anchor shaft causes the DIPK to expand in the base material.

Installation DIPK in concrete

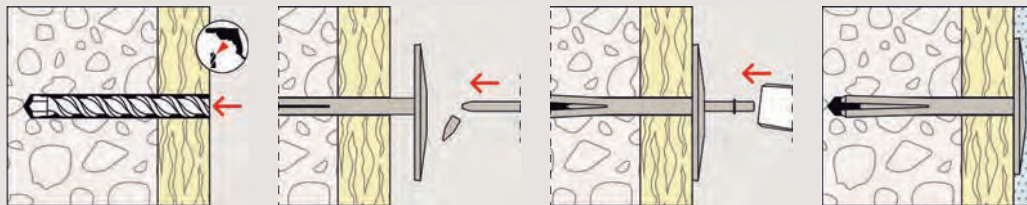

Installation DIPK in masonry

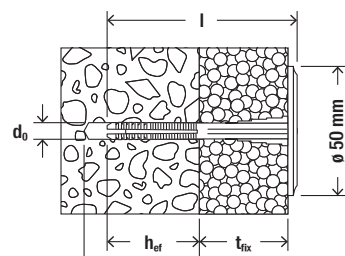
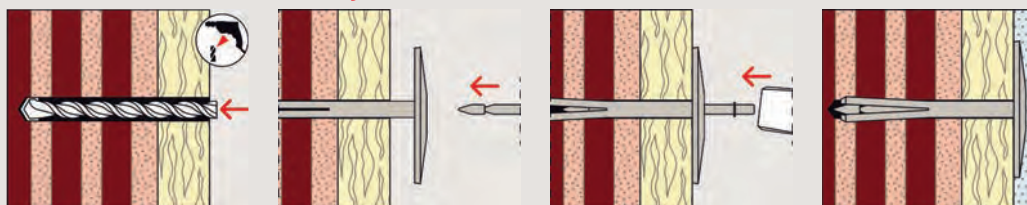

Technical data

Render fixing DIPK



DIPK

Item	Item No.	Drill hole diameter	Usable length	Min. drill hole depth	Effect. anchorage depth	Fixing length	Sales unit
		d_0 [mm]	t_{fix} [mm]	h_1 [mm]	h_{ef} [mm]	l [mm]	[pcs]
DIPK 8/20-40	041865	8	20 - 40	40	30	70	200
DIPK 8/40-60	041866	8	40 - 60	40	30	90	200
DIPK 8/60-80	041867	8	60 - 80	40	30	110	200
DIPK 8/80-100	041868	8	80 - 100	40	30	130	200
DIPK 8/100-120	041869	8	110 - 120	40	30	150	200
DIPK 10/10-30	043966	10	10 - 30	40	30	60	200
DIPK 10/40-60	043967	10	40 - 60	40	30	90	200
DIPK 10/60-80	043968	10	60 - 80	40	30	110	200
DIPK 10/80-100	043969	10	80 - 100	40	30	130	200
DIPK 10/100-120	043970	10	110 - 120	40	30	150	200
DIPK 10/120-140	043971 ¹⁾	10	120 - 140	40	30	170	200
DIPK 10/140-160	043972 ¹⁾	10	140 - 160	40	30	190	200

¹⁾ Installation with setting tool, included in each package.

Render fixing FIF-PN 8

The pre-assembled hammerset anchor with reinforced plastic nail



Polystyrene rigid foam boards



Setting the hammerset fixing on polystyrene rigid foam boards

Applications

- Fixing of ETICS insulation boards on concrete and masonry
- Flush-to-surface installation in ETICS insulating materials e.g. polystyrene

Approvals



ETA-18/0253, for concrete and masonry

Advantages

- To set with few hammer blows.
- The disc fits tight into the insulation thanks to its thickness of only 2.7 mm. Thus allows the application of low-cost, thin reinforcement layers.
- Optimised retention forces thanks to the glass fibre reinforced plastic nail (GRP).
- Small anchoring depth of 35 mm saves

Building materials

- Building material classes A, B, C, D, E
- Concrete
- Building brick
- Solid sand-lime brick
- Hollow blocks made from lightweight concrete
- Vertically perforated brick
- Perforated sand-lime brick
- Lightweight aggregate concrete
- Aerated concrete

- on drilling times.
- Thanks to the GRP nail, the fixing is free of thermal bridging with the Chi value 0.000 [W/K].
- The compression zone in the shank allows the disc to be drawn precisely into the insulation.
- For insulating material thicknesses up to 180 mm.

Functioning

- The fixing is set in push-through installation.
- Simple, fast setting by driving the GRP nail in using a standard hammer.
- Non load bearing layers such as adhesive and old plaster are included in the maximum useful length.

Installation FIF-PN 8

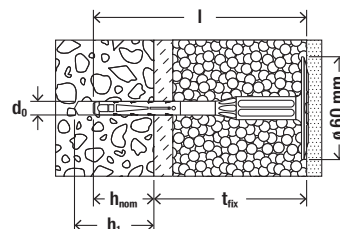
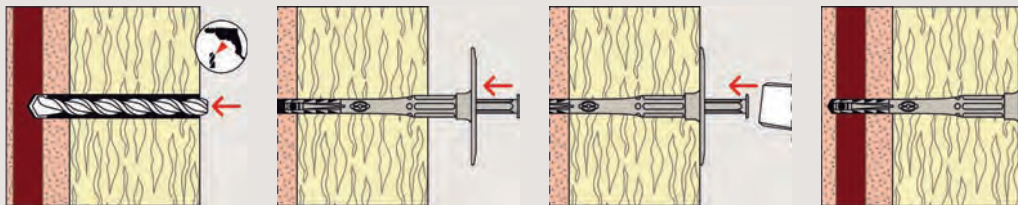

Technical data for building material categories A, B, C

Render fixing FIF-PN 8



FIF-PN 8

Item	Item No.	Approval	Drill hole diameter d_0 [mm]	Min. drill hole depth h_1 [mm]	Min. anchorage depth h_{nom} [mm]	Anchor length l [mm]	Max. fixture thickness t_{fix} [mm]	Disc Ø [mm]	Sales unit [pcs]
		ETA							
FIF-PN 8/60	546803	●	8	45	35	108	70	60	100
FIF-PN 8/80	546804	●	8	45	35	128	90	60	100
FIF-PN 8/100	546805	●	8	45	35	148	110	60	100
FIF-PN 8/120	546806	●	8	45	35	168	130	60	100
FIF-PN 8/140	546807	●	8	45	35	188	150	60	100
FIF-PN 8/160	546808	●	8	45	35	208	170	60	100
FIF-PN 8/180	546809	●	8	45	35	228	190	60	100

Technical data for building material categories D, E

Render fixing FIF-PN 8

Item	Item No.	Approval	Drill hole diameter d_0 [mm]	Min. drill hole depth h_1 [mm]	Min. anchorage depth h_{nom} [mm]	Anchor length l [mm]	Max. fixture thickness t_{fix} [mm]	Disc Ø [mm]	Sales unit [pcs]
		ETA							
FIF-PN 8/60	546803	●	8	65	55	108	50	60	100
FIF-PN 8/80	546804	●	8	65	55	128	70	60	100
FIF-PN 8/100	546805	●	8	65	55	148	90	60	100
FIF-PN 8/120	546806	●	8	65	55	168	110	60	100
FIF-PN 8/140	546807	●	8	65	55	188	130	60	100
FIF-PN 8/160	546808	●	8	65	55	208	150	60	100
FIF-PN 8/180	546809	●	8	65	55	228	170	60	100

Loads

Render fixing FIF-PN³⁾

Highest permissible loads for a single anchor^{1,4)} for fixing of external thermal insulation composite systems with rendering. For the design the complete assessment ETA-18/0253 has to be considered.

Type FIF-PN	Brick raw density ρ [kg/dm ³]	Minimum compressive brick strength f_b [N/mm ²]	Minimum embedment depth h_{nom} [mm]	Minimum member thickness h_{min} [mm]	Concrete and masonry		
					Permissible tensile load N_{perm} [kN]	Minimum-spacing ⁵⁾ s_{min} [mm]	Minimum edge distance ⁵⁾ c_{min} [mm]
Concrete according to EN 206-1:2013	-	C12/15 – C50/60	35 ⁶⁾	100	0.15	100	100
Solid clay bricks Mz according to EN 771-1:2011	≥ 2.0	12	35 ⁶⁾	100	0.15	100	100
Vertically perforated clay bricks HLz according to EN 771-1:2011	≥ 1.0	12	35 ⁷⁾	100	0.13	100	100
Lightweight aggregate concrete LAC according to EN 1520:2011	≥ 0.8	6	55 ⁶⁾	100	0.10	100	100
Autoclaved aerated concrete blocks AAC according to EN 771-4:2011	≥ 0.5	6	55 ⁷⁾	100	0.10	100	100

¹⁾ The partial safety factors for material resistance as regulated in the assessment as well as a partial safety factor for load actions of $\gamma_L = 1,5$ are considered.

²⁾ Possible minimum spacing resp. edge distance according to assessment.

³⁾ Plastic anchor for fixing of external thermal insulation composite systems with rendering according to. Only tensile wind loads are permitted.

⁴⁾ The given loads are valid for installation and use of fixations in dry base material for temperatures in the substrate up to +24 °C (resp. short term up to +40 °C).

⁵⁾ Restrictions concerning the manufacturer and the permissible hole patterns as well as the web thickness see assessment.

⁶⁾ Drill method hammer drilling.

⁷⁾ Rotary drilling.

Render fixing FIF-CN II 8

The pre-assembled hammerset anchor with innovative steel-plastic nail



Additional reinforcement of ETICS

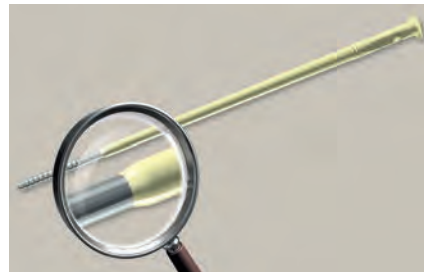

Detail: innovative steel-plastic combination

Applications

- Fixing of ETICS insulation boards on concrete and masonry
- Flush-to-surface installation in ETICS insulating materials like mineral wool or polystyrene boards

Advantages

- To set with few hammer blows.
- The plate fits tight into the insulation thanks to its thickness of only 2.7 mm. Thus allows the application of low-cost, thin reinforcement layers.
- High retention forces thanks to the steel

- tip of the compound nail.
- Small anchoring depth of 35 mm saves on drilling times.
- The compression zone in the shank allows the plate to be drawn in precisely.
- For insulating material thicknesses up to 340 mm.

Approvals



ETA-18/0393, for concrete and masonry

Building materials

- Building material classes A, B, C, D, E
- Concrete
- Full blocks made from concrete
- Building brick
- Solid sand-lime brick
- Hollow blocks made from lightweight concrete
- Vertically perforated brick
- Perforated sand-lime brick
- Lightweight aggregate concrete
- Aerated concrete

Functioning

- The fixing is set in push-through installation.
- Simple, fast setting by driving the compound nail in using a standard hammer.
- Non load bearing layers such as adhesive and old plaster are included in the maximum useful length.

Installation FIF-CN II 8

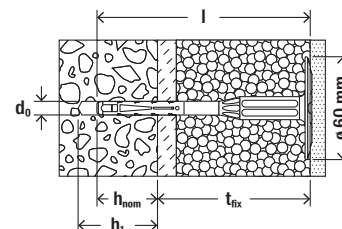
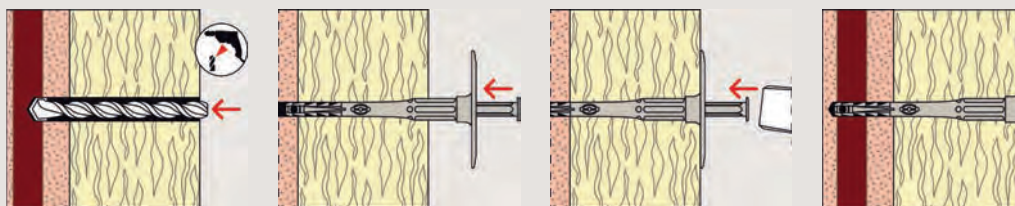

Technical data for building material categories A, B, C

Render fixing FIF-CN II 8



FIF-CN II 8

Item	Item No.	Approval	Drill hole diameter d_0 [mm]	Min. drill hole depth h_1 [mm]	Min. anchorage depth h_{nom} [mm]	Anchor length l [mm]	Max. fixture thickness t_{fix} [mm]	Disc \varnothing [mm]	Sales unit [pcs]
		ETA							
FIF-CN II 8/60	546443	●	8	45	35	108	70	60	100
FIF-CN II 8/80	546444	●	8	45	35	128	90	60	100
FIF-CN II 8/100	546445	●	8	45	35	148	110	60	100
FIF-CN II 8/120	546446	●	8	45	35	168	130	60	100
FIF-CN II 8/140	546447	●	8	45	35	188	150	60	100
FIF-CN II 8/160	546448	●	8	45	35	208	170	60	100
FIF-CN II 8/180	546449	●	8	45	35	228	190	60	100
FIF-CN II 8/200	546450	●	8	45	35	248	210	60	100
FIF-CN II 8/220	546451	●	8	45	35	268	230	60	100
FIF-CN II 8/240	546452	●	8	45	35	288	250	60	100
FIF-CN II 8/260	546453	●	8	45	35	308	270	60	100
FIF-CN II 8/280	546454	●	8	45	35	328	290	60	100
FIF-CN II 8/300	546455	●	8	45	35	348	310	60	100
FIF-CN II 8/320	546456	●	8	45	35	368	330	60	100
FIF-CN II 8/340	546457	●	8	45	35	388	350	60	100

Technical data for building material categories D, E

Render fixing FIF-CN II 8									
Item	Item No.	Approval	Drill hole diameter d_0 [mm]	Min. drill hole depth h_1 [mm]	Min. anchorage depth h_{nom} [mm]	Anchor length l [mm]	Max. fixture thickness t_{fix} [mm]	Disc Ø [mm]	Sales unit [pcs]
		ETA							
FIF-CN II 8/60	546443	●	8	65	55	108	50	60	100
FIF-CN II 8/80	546444	●	8	65	55	128	70	60	100
FIF-CN II 8/100	546445	●	8	65	55	148	90	60	100
FIF-CN II 8/120	546446	●	8	65	55	168	110	60	100
FIF-CN II 8/140	546447	●	8	65	55	188	130	60	100
FIF-CN II 8/160	546448	●	8	65	55	208	150	60	100
FIF-CN II 8/180	546449	●	8	65	55	228	170	60	100
FIF-CN II 8/200	546450	●	8	65	55	248	190	60	100
FIF-CN II 8/220	546451	●	8	65	55	268	210	60	100
FIF-CN II 8/240	546452	●	8	65	55	288	230	60	100
FIF-CN II 8/260	546453	●	8	65	55	308	250	60	100
FIF-CN II 8/280	546454	●	8	65	55	328	270	60	100
FIF-CN II 8/300	546455	●	8	65	55	348	290	60	100
FIF-CN II 8/320	546456	●	8	65	55	368	310	60	100
FIF-CN II 8/340	546457	●	8	65	55	388	330	60	100

Loads

11

Render fixing FIF-CN II

Permissible loads for a single anchor¹⁾²⁾ for fixing of external thermal insulation composite systems with rendering. For the design the complete assessment ETA-18/0393 has to be considered.

Type FIF-CN II	Brick raw density ρ [kg/dm ³]	Minimum compressive brick strength f_b [N/mm ²]	Minimum embedment depth h_{nom} [mm]	Minimum member thickness h_{min} [mm]	Concrete and masonry ⁴⁾		
					Permissible tensile load N_{perm} [kN]	Minimum-spacing ⁵⁾ s_{min} [mm]	Minimum edge distance ⁵⁾ c_{min} [mm]
Concrete acc. to EN 206-1:2000	-	C12/15 – C50/60	35 ⁶⁾	100	0.25	100	100
Solid clay bricks Mz according to EN 771-1:2011	≥ 2.0	12	35 ⁶⁾	100	0.25	100	100
Vertically perforated clay bricks HLz according to EN 771-1:2011	≥ 1.0	12	35 ⁷⁾	100	0.17	100	100
Lightweight aggregate concrete LAC according to EN 1520:2011	≥ 0.8	6	55 ⁶⁾	100	0.17	100	100
Autoclaved aerated concrete blocks AAC according to EN 771-4:2011	≥ 0.4	4	55 ⁷⁾	100	0.10	100	100

¹⁾ Plastic anchor for fixing of external thermal insulation composite systems with rendering acc. to ETA data. Only tensile wind loads are permitted.

²⁾ The partial safety factors for material resistance as regulated in the assessment as well as a partial safety factor for load actions of $\gamma_L = 1.5$ are considered.

³⁾ The given loads are valid for installation and use of fixations in dry base material for temperatures in the substrate up to +24 °C (resp. short term up to +40 °C).

⁴⁾ Restrictions concerning the manufacturer and the permissible hole patterns as well as the web thickness see assessment.

⁵⁾ Possible minimum spacing resp. edge distance according to assessment.

⁶⁾ Drill method hammer drilling.

⁷⁾ Rotary drilling.

Render fixing FIF-CS 8

The economic screw fixing for all ETICS insulation materials



Screwed fixing of insulation boards



Polystyrene rigid foam boards O35 on perforated sand-lime brick

Applications

- Fixing of ETICS insulation boards on concrete and masonry
- Flush installation in all conventional insulation materials

Approvals



ETA-15/0006, for concrete and masonry

Advantages

- Compound screw minimises the thermal bridge, thus there are no fixing marks on the façade.
- Less drill wear and drill time due to minimum installation depth of 35 mm in the substrate.
- With flush installation, the disc tapers to a

Building materials

- Building material classes A, B, C, D, E
- Concrete
- Concrete (weather shell)
- Building brick
- Solid sand-lime brick
- Hollow blocks made from lightweight concrete
- Vertically perforated brick
- Perforated sand-lime brick
- Lightweight aggregate concrete
- Aerated concrete

very thin edge, thus providing for optimal retaining of the insulation panel and for application of thin render.

- For insulation material thicknesses up to 340 mm.
- Standard embedment depth for all building materials.

Functioning

- The fixing is pushed through the insulation into the drilled hole and is screwed tight.
- For lengths from 250 mm, at least 180 mm long T25 bits are required. These are not included in the delivery assortment.

Installation FIF-CS 8

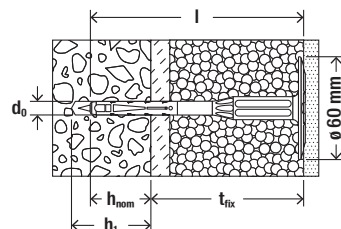
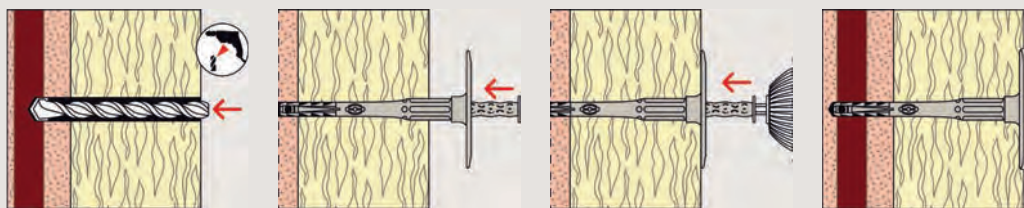

Technical data

Render fixing FIF-CS 8



FIF-CS 8

Item	Item No.	Approval ETA	Drill hole diameter d_0 [mm]	Min. drill hole depth h_1 [mm]	Effect. anchorage depth h_{ef} [mm]	Anchor length l [mm]	Max. fixture thickness t_{fix} [mm]	Disc \varnothing [mm]	Sales unit [pcs]
FIF-CS 8/60	534157	●	8	45	35	108	70	60	100
FIF-CS 8/80	534158	●	8	45	35	128	90	60	100
FIF-CS 8/100	534159	●	8	45	35	148	110	60	100
FIF-CS 8/120	534160	●	8	45	35	168	130	60	100
FIF-CS 8/140	534161	●	8	45	35	188	150	60	100
FIF-CS 8/160	534162	●	8	45	35	208	170	60	100
FIF-CS 8/180	534163	●	8	45	35	228	190	60	100
FIF-CS 8/200	534164	●	8	45	35	248	210	60	100
FIF-CS 8/220	534165	●	8	45	35	268	230	60	100
FIF-CS 8/240	534166	●	8	45	35	288	250	60	100
FIF-CS 8/260	534167	●	8	45	35	308	270	60	100
FIF-CS 8/280	534168	●	8	45	35	328	290	60	100
FIF-CS 8/300	534169	●	8	45	35	348	310	60	100
FIF-CS 8/320	534170	●	8	45	35	368	330	60	100
FIF-CS 8/340	534171	●	8	45	35	388	350	60	100

Loads

Render fixing FIF-CS³⁾

Highest permissible loads for a single anchor^{1,4)} for fixing of external thermal insulation composite systems with rendering. For the design the complete assessment ETA-15/0006 has to be considered.

Type FIF-CS	Brick raw density ρ [kg/dm ³]	Minimum compressive brick strength f_b [N/mm ²]	Minimum embedment depth h_{nom} [mm]	Minimum member thickness h_{min} [mm]	Concrete and masonry ⁵⁾		
					Permissible tensile load ³⁾ N_{perm} [kN]	Minimum spacing ²⁾ s_{min} [mm]	Minimum edge distance ²⁾ c_{min} [mm]
Concrete acc. to EN 206-1:2000	-	C12/15 – C50/60	35 ⁶⁾	100	0.40	100	100
Solid clay bricks Mz according to EN 771-1:2011	≥ 1.8	20	35 ⁶⁾	100	0.40	100	100
Vertically perforated clay bricks HLz according to EN 771-1:2011	≥ 1.0	12	25 ⁷⁾	100	0.20	100	100
Lightweight aggregate concrete LAC according to EN 1520:2011	≥ 0.9	6	35 ⁶⁾	100	0.20	100	100
Autoclaved aerated concrete blocks AAC according to EN 771-4:2011	≥ 0.5	4	35 ⁷⁾	100	0.10	100	100

¹⁾ The partial safety factors for material resistance as regulated in the assessment as well as a partial safety factor for load actions of $\gamma_L = 1,5$ are considered.

²⁾ Possible minimum spacing resp. edge distance according to assessment.

³⁾ Plastic anchor for fixing of external thermal insulation composite systems with rendering according to ETAG014. Only tensile wind loads are permitted.

⁴⁾ The given loads are valid for installation and use of fixations in dry base material for temperatures in the substrate up to +24 °C (resp. short term up to +40 °C).

⁵⁾ Restrictions concerning the manufacturer and the permissible hole patterns as well as the web thickness see assessment.

⁶⁾ Drill method hammer drilling.

⁷⁾ Rotary drilling.

Insulation Disc DT

The insulation disc for combination with termoz and termofix screw fixings

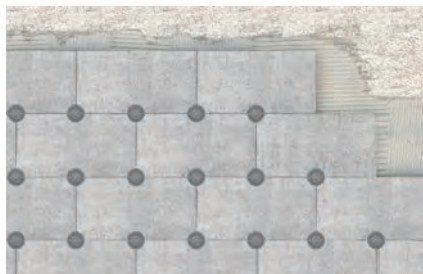
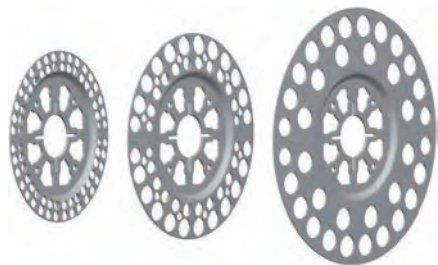

Flush mounting of wood fibre boards on wood constructions

Applications

- Used in combination with TermoZ, FIF and TermoFix anchors to fix ETICS insulating boards with low compressive strength
- Flush surface installation in ETICS insulating materials e.g. mineral wool

Advantages

- The various disc diameters allow for individual adaptation to various insulation materials and requirements and offer

the greatest flexibility with wide-ranging applications.

Functioning

- The discs are set in push-through installation.
- Push the selected DT insulating disc onto the TermoZ, FIF or TermoFix anchor and fit.

Technical data

Insulation discs DT



DT 90



DT 110



DT 140

Item	Item No.	Through hole [mm]	Sales unit [pcs]
DT 90	008889	16	100
DT 110	090745	16	100
DT 140	008690	16	100

Insulation discs

Discs for combining nail and frame fixings, as well as screws

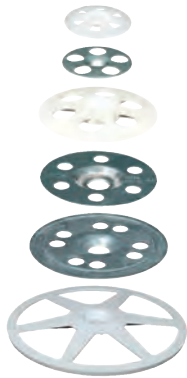

Insulating materials in two-leaf external walls

Applications

- To fix soft and pressure-resistant insulation materials.
- DT 90/4 on VB wall tie
- DT 60/10, DTM 60/10 and DTM 70/10 in combination with 10 mm frame fixing
- DT 90/8 and insulation washer 8/60 in combination with 8 mm frame or nail fixings
- HV and HK 36 with 5 mm screws

Advantages

- The various disc diameters allow for individual adaptation to various insulation materials and requirements and offer the greatest flexibility with wide-ranging applications.
- The flexible pins in the DT 90 ensure sustained pressure on the insulation, thus

providing a secure hold.

- The DTM 60 made of stainless steel A4 makes it possible to use a frame fixing, and allows for a secure fixing of the insulation material in façade construction in cases of high requirements.

11

Functioning

- The disc size is to be selected in line with the compressive strength of the insulating material.
- To be combined with anchors, screws or nails corresponding to the available base material.
- DT 90/4 is suitable for pushing on to fischer wall tie VB.

Technical data

Insulation discs



HK 36 plastic

HV 36 zinc

ISO-disk 8/60

DT 60/10

DTM-A4

DTM 70/10

Item	Item No.	Disc Ø [mm]	Disc height [mm]	Through hole d _f [mm]	Steel sheet thickness s [mm]	Sales unit [pcs]
HK 36 plastic	004283	36	4,5	5	—	100
HV 36 zinc	004286	36	3,5	5	0,7	100
ISO-disk 8/60	001680	60	7	8	—	100
DT 60/10	044317	60	7	10	—	50
DTM 60/10 A4	088805	60	3	10,5	0,5	100
DTM 70/10 zinc	044318	70	3	10,5	—	50

11

Technical data

Insulation discs DT



DT 90

Item	Item No.	Disc Ø [mm]	Disc height [mm]	Through hole [mm]	Sales unit [pcs]
DT 90/4	080957 ¹⁾	90	9,3	4	250
DT 90/8	080958	90	9,3	8,2	250

¹⁾ The central hole is adapted in such a way that the disc clamps well on the 4 mm wire of the VB walltie.

TermoFix H

The disc element for use with standard screws



Flush mounting of mineral wool boards

Applications

- Fixing of ETICS insulation boards with standard screws

Advantages

- The polystyrene plugs are included with the disc element TermoFix H 10.
- In case of disc elements TermoFix H 50, 90 and 150 the disc is sealed using the sealing cap moulded on.
- An air column is produced between the screw head and this seal. This reduces

- thermal-transmission losses.
- Extremely economical thanks to different shank lengths. This allows the screw length to be reduced if necessary.
- Can be combined with the insulating discs DT 90, DT 110 and DT 140.

Building materials

- Panel building materials
- Solid wood

Functioning

- The fixing (disc and screw) is set in push-through installation.
- Non-load-bearing layers such as adhesive and old plaster should not serve as an anchoring base.

Technical data

TermoFix H



TermoFix H 10



TermoFix H 50



TermoFix H 90



TermoFix H 150

Item	Item No.	Shaft length [mm]	Disc Ø [mm]	Disc lock	Colour	Sales unit [pcs]
TermoFix H 10	514288	29	60	PS plug (included)	green	200
TermoFix H 50	514289	69	60	Sealing cap (moulded on)	green	100
TermoFix H 90	514290	109	60	Sealing cap (moulded on)	green	100
TermoFix H 150	514291	169	60	Sealing cap (moulded on)	green	100

Retaining disc with screw DHT S

The installation-friendly polyamide retaining disc for panel building materials



Pressure-resistant insulation boards on timber constructions



Pressure-resistant insulation boards on timber constructions

Applications

To fix pressure-resistant insulating materials in plaster façades, such as:

- Polystyrene
- PU panels
- Light building boards made of wood wool
- Cork boards / coir matting

Advantages

- The DHT-S screw allows setting without pre-drilling, thus saving a stage of installation.
- The plug reduces the heat transmission and prevents marks on the plaster surface.

- The extremely thin disc construction allows for use with thin layers of plaster and reinforcements and offers maximum flexibility.

Certificates



Building materials

- Wood and wooden materials
- Board thickness up to 0.8 mm

Functioning

- Non-bearing layers, such as adhesive, are to be included in the useful length.
- The retaining disc with screw is set in push-through installation with a cordless screwdriver.
- A PH2 bit is required for installation.
- After installation, seal the screw hole with the enclosed plug.

Installation DHT S

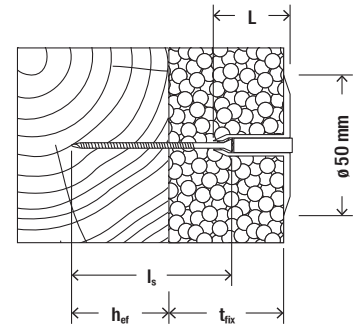
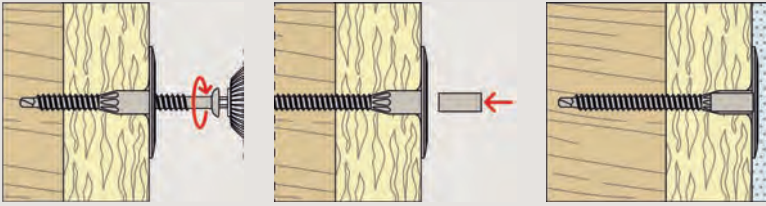

Technical data

Retaining disc with screw DHT S



DHT 50/ ... disc



DHT S

Item	Item No.	Colour	Usable length	Shaft length	Screw length	Effect. anchorage depth	Disc Ø	Sales unit
			t_{fix} [mm]	L [mm]	l_s [mm]	h_{eff} [mm]		
DHT 50/20 W	044490	white	—	20	—	—	50	500
DHT 50/40 W	044491	white	—	40	—	—	50	500
DHT S 30 W	044390	white	30	20	45	25	50	500
DHT S 50 W	044392	white	40 - 50	20	65	25	50	500
DHT S 70 W	044394	white	60 - 70	40	65	25	50	500
DHT S 80 W	044395	white	70 - 80	40	75	25	50	500
DHT S 100 W	044388	white	90 - 105	40	100	25	50	500
DHT S 120 W	044389	white	110 - 125	40	120	25	50	500
DHT S 150 W	516154	white	140 - 155	40	150	25	50	500

Insulation fixing FID

Thermal bridge-free installation in insulation materials



Letterbox



External lighting

Applications

To fix lightweight attachments on ETICS facades. The application areas are ETICS facades made of:

- Polystyrene
- Mineral wool
- Soft wood fibre
- Alternative ecological insulation boards

Advantages

- Since the anchor is set exclusively in the insulation itself, fixtures can be installed without thermal bridges.
- The geometry of the FID allows for a simple installation in thin layers of plaster, without the need for pre-drilling, thus saving a stage of installation.
- The FID 50 is used in thin insulating

boards from 50mm. The FID 90 is used in thicker insulating boards, and can bear higher loads.

- The bit mounting allows for setting with standard tools, thus allowing for a fast and economic installation.

Building materials

- Non-plastered, pressure-resistant insulating boards
- Plastered, pressure-resistant insulating boards
- ETICS insulating boards

Functioning

- The FID can be set in the insulating board with a cordless screwdriver or by hand.
- The special spiral thread taps itself in the insulating board.
- Fixtures are fixed with a 4.5 mm screw for the FID 50, and with a 6 mm screw for the FID 90.
- Water ingress in the insulation can be prevented by sealing the plug collar with a suitable sealant after successful pre-positioned installation.
- We recommend to predrill an 6 mm hole in ETICs rendering.

Installation FID

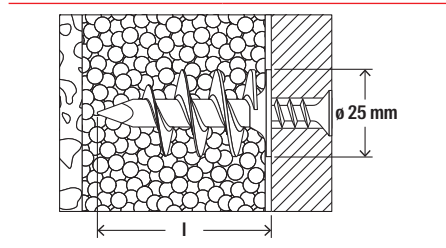
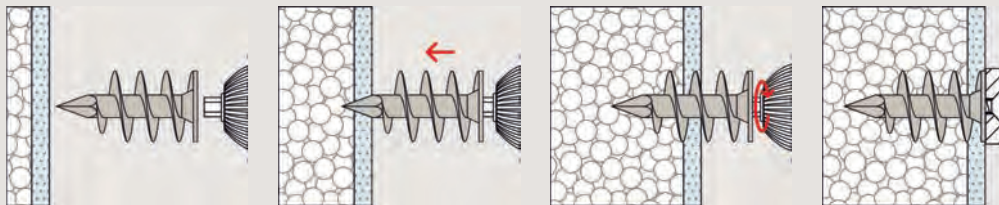

Technical data

Insulation fixing FID



FID 50

FID 90

Item	Item No.	Anchor length l [mm]	Min. bolt penetration [mm]	Wood and chipboard screws d _s [mm]	Drive	Sales unit [pcs]
FID 50	048213	50	50	4,5 - 5	T40	50
FID 90	510971	90	90	6	6 mm / 6-kt	25

Loads

Insulation fixing FID

Recommended loads¹⁾ for a single anchor.
The given loads are valid for chipboard screws with maximum diameter.

Type		FID 50	FID 90
Screw diameter	[mm]	4.5 - 5,0	6.0
Recommended loads in the respective base material N _{rec} ²⁾			
Polystyrene	PS 15	[kN] 0.07	0.17
Polystyrene	PS 20	[kN] 0.10	0.20

¹⁾ Required safety factors are considered.

²⁾ Valid for tensile loads.

Insulation fixing FID-R

Thermal bridge-free installation of rainwater downpipes in insulation materials



Rainwater downpipes

Applications

- Thermal bridge-free installation of rainwater downpipes

Advantages

- Since the anchor is set exclusively in the insulation itself, fixtures can be installed without thermal bridges. The anchor offers an energy-optimised fixing.
- The hard-centering tip cuts its own way through the plaster, without the need

for pre-drilling, thus saving a stage of installation.

- The TX-drive allows for setting with standard tools, thus allowing for a fast and economic installation.

Building materials

- Polystyrene insulating boards
- Wood fibre insulating boards
- External thermal insulation composite system (ETICS)

Functioning

- The installation is carried out without any special tools.
- The spiral thread taps itself in the insulation board.
- For the installation in wood fibre insulating boards a pre-drilling of the insulating board with 16 mm is necessary.
- For the installation before plastering the threaded rod is protected by a tube sleeve.
- The included white covering rosette with glued on PE sealing disc protects against humidity.

Installation in plastered insulating boards

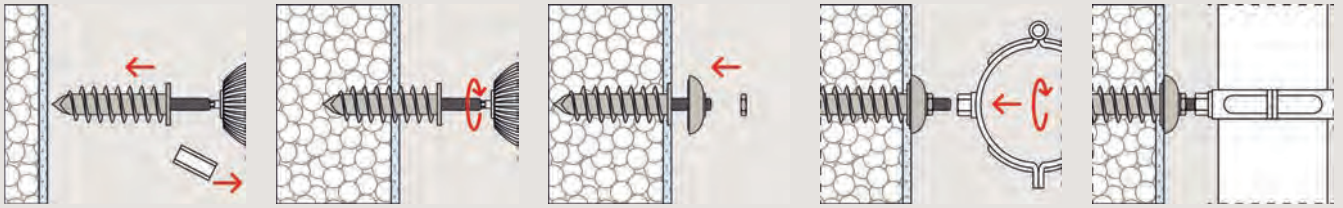

Installation in non-plastered insulating boards

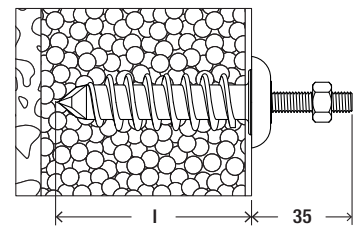
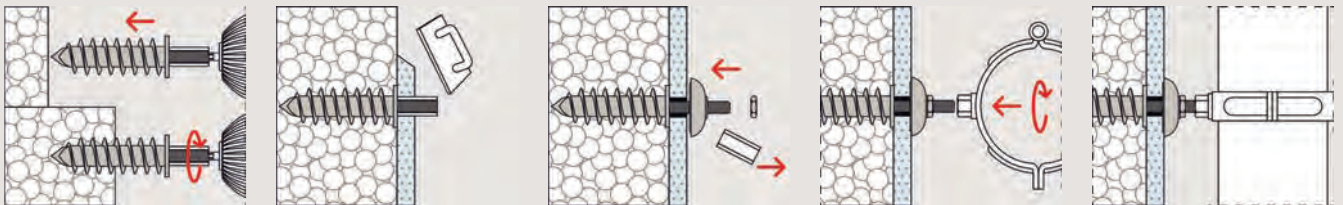

Technical data

Insulation fixing FID-R



FID-R

Item	Item No.	Anchor length l [mm]	Min. bolt penetration [mm]	Drive	Thread A	Sales unit [pcs]
FID-R zI	548404	95	95	T25	M 10	25
FID-R zI B	548405	95	95	T25	M 10	5

Loads

Insulation fixing FID-R

Recommended loads¹⁾ for a single anchor.

Type		FID-R
Recommended loads in the respective base material N_{rec} ²⁾		
Polystyrene	PS 15	[kN] 0.17
Polystyrene	PS 20	[kN] 0.20

¹⁾ Required safety factors are considered.

²⁾ Valid for tensile loads.

Insulation fixing FID Green

Thermal bridge-free installation in insulation materials



External lighting



Letterbox

Applications

To fix lightweight attachments on ETICS facades. The application areas are ETICS facades made of:

- Polystyrene
- Mineral wool
- Soft wood fibre
- Alternative ecological insulation boards

Certificates



Advantages

- Produced with at least 50% renewable raw materials and therefore particularly environmentally friendly.
- Just as effective, secure and durable as regular FID plugs. To fix lightweight fixtures in plastered and non-plastered

Building materials

- Non-plastered, pressure-resistant insulating boards
- Plastered, pressure-resistant insulating boards
- ETICS insulating boards

insulating boards.

- Thermal bridge-free mounting when exclusively set in insulation material.
- Installation without pre-drilling even through thin plaster layers, thus saving a work step.
- Easy to set using a standard bit.

Functioning

- The FID GREEN can be set in pre-positioned installation with a cordless screwdriver or by hand.
- With its strong drill tip, the insulation fixing FID GREEN breaks through thin plaster layers and cuts a positive fit into the insulation panel with its specially shaped spiral thread.
- From a plaster thickness of 5 mm, we recommend to create a 6 mm hole. This serves for better guidance of the fastener in the setting process.
- Water ingress in the insulation material can be prevented by sealing the plug collar after successful installation.
- Attachment parts can be easily attached with screws.
- We recommend to predrill an 6 mm hole in ETICS rendering.

Installation FID Green

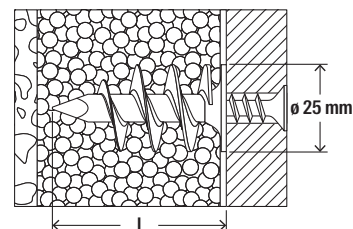
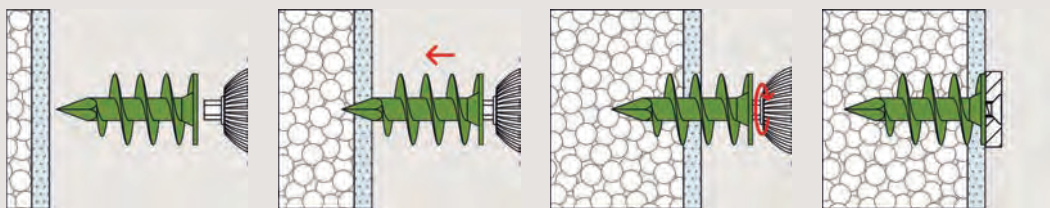

Technical data

Insulation fixing FID Green



FID Green 50



FID Green 90

Item	Item No.	Anchor length l [mm]	Min. bolt penetration [mm]	Wood and chipboard screws d _s [mm]	Drive	Sales unit [pcs]
FID Green 50	524851	50	50	4,5 - 5	T40	45
FID Green 90	524852	90	90	6	Inbus 6 mm	20

11

Loads

Insulation fixing FID Green

Recommended loads¹⁾ for a single anchor.

The given loads are valid for chipboard screws with maximum diameter.

Type		FID Green 50	FID Green 90
Screw diameter	[mm]	4.5 - 5,0	6.0
Recommended loads in the respective base material N _{rec} ²⁾			
Polystyrene	PS 15	[kN] 0.07	0.17
Polystyrene	PS 20	[kN] 0.10	0.20

¹⁾ Required safety factors are considered.

²⁾ Valid for tensile loads.

Holding clamp DVN

The installation-friendly insulation clamp



Pressure-resistant insulation boards on timber constructions



Pressure-resistant insulation boards on ceiling undersides

Applications

- To fix pressure-resistant insulation materials (e.g. polystyrene, PU panels, glass foam boards) onto timber sub-structures, predominantly in the ceiling area

Advantages

- The holding clamp DVN allows for a hidden installation for a homogeneous surface.
- The complete fixing system, comprising the clamp and zinc-plated nails, allows for an immediate installation in line with

building requirements.

- The Sendzimir-galvanised steel claw allows for durable use for the secure anchoring of pressure-resistant insulation materials.

11

Installation DVN

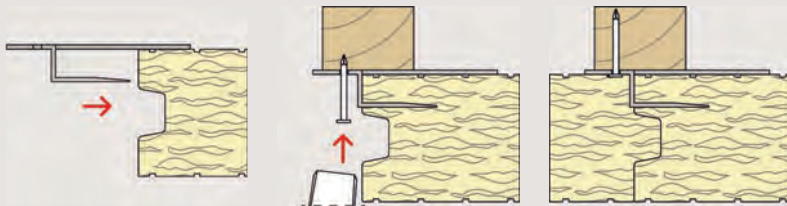

Technical data

Holding clamp DVN

































DVN

Item	Item No.	For insulation thickness [mm]	Sales unit [pcs]
DVN 15	047240	up to 60	250
DVN 30	047243	from 80	250



12

Foams and sealants

1c premium installation foam PU 500/750	554		Sealant selection matrix	570	
1c rapid installation foam PU S 500/750 B2	555		Premium sanitary silicone DSSA	574	
1c premium flex foam PUP FLEX 750 B2	556		Sanitary silicone DSSI	576	
1c premium gun foam PUP 750 B2	558		Multi-silicone DMS	577	
1c premium gun foam compact PUP 500 B2	559		Premium high temperature silicone DHS	578	
1c gun foam PUP S 750 B2	560		Premium construction silicone DBSA	579	
1c maxi gun foam PUP S 500 B2	561		Roof and wall silicone DBSI	581	
1c premium gun foam PUP 750 B3	562		Premium silicone 1 For All DNS	582	
1c premium gun foam PUP B1 750	563		Premium B1 silicone DFS	583	
1c premium gun foam PUP BS 750 B2	564		Premium painting acrylic DMA	584	
1c perimeter adhesive foam PUP P 750	565		Premium structured acrylic DSA	585	
1c adhesive foam PUP ETICS 750	566		Acrylic sealant DA	586	
2c premium rapid foam 2K PU 400 Plus	567		Repair mortar DEC	587	
Accessories	568		Premium all-weather sealant DDK	588	
			Roof sealing compound DD	589	
			Accessories for sealants	590	
			Zinc spray FTC-ZS	592	
			Zinc-alu spray FTC-ZA	593	

1c premium installation foam PU 500/750

The high-quality one-component rapid installation foam with reusable fix adapter system



Window connection joints



Sealing concrete manhole rings

Applications

- Bonding and sealing manhole rings
- Insulating and filling in roofing work and dry construction
- Insulating and filling window connection joints, around window sills and shutter boxes
- Insulating and filling finished elements, wall connections and wall penetrations

Advantages

- The reclosable fix adapter allows for immediate use and for the reuse of opened cans, thus guaranteeing long-lasting functionality.
- The used solid valve prevents adhesion when being stored horizontally and premature gas loss.
- The rapid installation foam has been

approved as watertight by an external inspection and is thus suitable for use in wet conditions. It fulfils the requirements of a well foam.

- The ergonomic handle sits perfectly in the hand and allows for easy use.

Building materials

Bonds to all standard building materials such as:

- Concrete
- Anodised layer
- Gypsum plasterboard
- Wood
- Sand-lime brick
- Plastics (not on PE, PP, Teflon, silicone)
- Masonry
- Metals with priming coat
- Plaster

Certificates

- General test certificate from building authorities P-NDS04-136 for B2
- Proven joint soundproofing: R(ST,w)=61 (-1; -3) dB in line with ISO EN 717-1
- Test for watertightness for the adhesion of manhole rings

Functioning

- 1-component PU foam
- Building material class B2 or B3
- Processing temperature environment: +5 °C to +35 °C (can temperature: +5 °C to +25 °C)
- Non-tacky after approx. 20 minutes
- Can be cut after approx. 40 minutes
- Cures within 5 to 8 hours
- Temperature resistant from -40 °C to +90 °C
- Layer thicknesses > 50 mm: foam in several layers and then dampen.
- Fresh foam stains can be removed immediately with fischer PU cleaner.

Technical data

1c premium installation foam PU 500/750

Item	Item No.	Content per can [ml]	Max. foam yield (free foaming) [l]	Adapter system	Colour	Sales unit [pcs]
PU 500 B2 (DE)	050426 ¹⁾	500	30	fischer FixAdapter	beige	12
PU 500 B3 (EN/FR/AR)	058500 ¹⁾	500	28	fischer FixAdapter	beige	12
PU 750 B2 (DE)	053080 ¹⁾	750	45	fischer FixAdapter	beige	12
PU 750 B3 (EN/FR/AR)	050427 ¹⁾	750	41	fischer FixAdapter	beige	12
PU 1/500 B3 HandHeld (EN/FR)	098010 ¹⁾	500	28	Standard adapter	beige	12
PU 1/750 B3 HandHeld (EN/FR)	098011 ¹⁾	750	41	Standard adapter	beige	12

¹⁾ Dangerous goods - no express shipping possible.

1c rapid installation foam PU S 500/750 B2

The high-quality rapid installation foam with proven sound insulation and resistance of water pressure



Window connection joints



Sealing concrete manhole rings

Applications

- Insulating and filling window connection joints, around window sills and shutter boxes
- Bonding and sealing manhole rings
- Insulating and filling in roofing work and dry construction
- Insulating and filling finished elements, wall connections, wall penetrations and cavities

Building materials

Bonds to all standard building materials such as:

- Concrete
- Anodised layer
- Gypsum plasterboard
- Wood
- Sand-lime brick
- Plastics (not on PE, PP, Teflon, silicone)
- Masonry
- Metals with priming coat
- Plaster

Advantages

- The proven 63 dB sound insulation fulfills the modern sound insulation and helps to reduce noise.
- The adapter foam has been approved as watertight by an external inspection and is thus suitable for use in wet conditions.

It fulfils the requirements of a well foam.

- The fast screwed adapter allows immediate use and is thus uncomplicated to use without need for additional processing equipment.
- The new non-sticking safety valve guarantees long-lasting functionality.

12

Certificates

- General test certificate from building authorities P-NDS04-136 for B2
- Proven joint soundproofing for B2: $R(ST,w) \geq 63$ (-1; -4) dB according ISO 10140-1
- Test for watertightness for the adhesion of manhole rings
- French VOC-emission class A+

Functioning

- 1-component PU foam
- Building material class B2
- Processing temperature environment: +5 °C to +30 °C (can temperature: +5 °C to +25 °C)
- Non-tacky after approx. 15 minutes
- Can be cut after approx. 45 minutes
- Hardened after approx. 24 hours
- Temperature resistant from -40 °C to +90 °C
- Layer thicknesses > 50 mm foam in several layers and then dampen.
- Fresh foam stains can be removed immediately with fischer PU cleaner.

Technical data

1c rapid installation foam PU S 500/750 B2					
Item	Item No.	Content per can [ml]	Max. foam yield (free foaming) [l]	Colour	Sales unit [pcs]
PU S 1/500 B2 (DE)	040300 ¹⁾	500	30	beige	12
PU S 750 (DE)	040301 ¹⁾²⁾	750	45	beige	12

1) Dangerous goods - no express shipping possible.

2) Without protective gloves, for commercial users only.

1c premium flex foam PUP FLEX 750 B2

The elastic one-component gun foam for all-season use with high sound and heat insulation



Window connection joints



Connection joints around shutter boxes

Applications

- For elastic insulation and filling of window connections, roller shutter boxes, window sills and external doors
- For elastic insulation and filling of areas with higher component movement due to thermal or static loads, e.g. in the old-building renovation, in steel construction, in timber-frame construction
- Permanent, elastic foaming of connection joints and cavities in wooden structures and roof extensions, e.g. connection joints on roof windows, dormers, gables, rafters, purlins, eave
- Permanently elastic filling of pipe penetrations, wall penetrations, wall connections and cavities

Building materials

Bonds to all standard building materials such as:

- Concrete
- Anodised layer
- Gypsum plasterboard
- Wood
- Sand-lime brick
- Plastics (not on PE, PP, Teflon, silicone)
- Masonry
- Metals
- Plaster
- Stone

Advantages

- The high elasticity enables the absorption of component movements. This permanently prevents the formation of cracks and thermal bridges and maintains the airtightness.
- The excellent dimensional stability of < 5% guarantees reliable operation under the temperature and humidity conditions that occur. This avoids time-consuming

- reworking.
- Thanks to its winter suitability, the large processing range from -10°C to +35°C enables reliable processing even at minus temperatures. These important requirements are combined in one product.
- The high joint sound insulation of 62 dB meets the standards of modern sound insulation and significantly reduces noise pollution.

Certificates

- General test certificate from building authorities DIN 4102: B2
- Tested joint sound insulation
- Tested air permeability
- Tested thermal conductivity EMICODE® EC 1 Plus - very low emission

Functioning

- 1-component PU foam
- Building material class B2
- Fine-cell and homogeneous foam structure
- Very high elasticity (3 times more flexible)
- Excellent dimensional stability < 5%
- Processing temperature ambient -10 °C to +35 °C (can +5 °C to +35 °C)
- Tack-free within approx. 10 min.
- Can be cut within approx. 30 min.
- Fully cured within approx. 24 h.
- Temperature resistant from -40 °C to +90 °C
- Layer thicknesses > 50 mm: foam in several layers and then dampen
- Fresh foam can be removed immediately with fischer PUR cleaner.

Technical data

1c premium flex foam PUP FLEX 750 B2

Item	Item No.	Content per can [ml]	Max. foam yield (free foaming) [l]	Colour	Sales unit [pcs]
PUP FLEX 750 B2 (DE)	543453 ¹⁾	750	48	cream	12
PUP FLEX 750 B2 (EN)	543451 ¹⁾	750	48	cream	12

1) Dangerous goods - no express shipping possible.

1c premium gun foam PUP 750 B2

The one-component gun foam with proven sound and thermal insulation as well as increased foam yield



Window connection joints



Connection joints around shutter boxes

Applications

- Insulating and filling window connection joints, around window sills and shutter boxes
- Insulating and filling in roofing work and dry construction
- Insulating and filling finished elements, wall connections, wall penetrations and cavities
- Insulating and filling pipe penetrations and ventilation ducts

Advantages

- The thermal protection and proven reduction of air permeability fulfil the high standards for modern thermal protection.
- The proven 61dB sound insulation fulfils the standards of modern sound insulation and helps to reduce noise.
- The high yield of up to 55 l reduces the number of cans needed, thus ensuring maximum economic efficiency.
- The low level of foam expansion during the curing period avoids reworking, thus guaranteeing a simple and time-saving application.
- The new safety valve prevents adhesion when being stored horizontally or during long interruptions of work, thus guaranteeing long-lasting functionality.

Building materials

Bonds to all standard building materials such as:

- Concrete
- Anodised layer
- Gypsum plasterboard
- Wood
- Sand-lime brick
- Plastics (not on PE, PP, Teflon, silicone)
- Masonry
- Metals with priming coat
- Plaster

Certificates

- General test certificate from building authorities P-NDS04-137
- Proven joint soundproofing $R(ST,w)=61$ (-1;-3) dB in line with ISO EN 717-1
- Proven thermal conductivity: Reduces heat loss by $0.0345 \text{ W}/(\text{m}^2\text{K})$
- Based on DIN 18542, proven airtightness of $a < 0.1 \text{ m}^3/[\text{h}^* \text{m}^2 (\text{daPa})^{2/3}]$
- French VOC-emission class A+
- EMICODE® EC 1 Plus - very low emission

Functioning

- 1-component PU foam
- Building material class B2
- Processing temperature environment: $+5 \text{ }^\circ\text{C}$ to $+35 \text{ }^\circ\text{C}$ (can temperature: $+10 \text{ }^\circ\text{C}$ to $+30 \text{ }^\circ\text{C}$)
- Non-tacky after 8 - 12 minutes
- Can be cut after 40 - 60 minutes
- Hardened after 80 - 100 minutes
- Temperature resistant from $-40 \text{ }^\circ\text{C}$ to $+90 \text{ }^\circ\text{C}$
- Layer thicknesses $> 50 \text{ mm}$: foam in several layers and then dampen.
- Fresh foam stains can be removed immediately with fischer PU cleaner.

Technical data

1c premium gun foam PUP 750 B2

Item	Item No.	Content per can [ml]	Max. foam yield (free foaming) [l]	Colour	Sales unit [pcs]
PUP 750 B2 (DE)	053084 ¹⁾	825	55	beige	12

¹⁾ Dangerous goods - no express shipping possible.

1c premium gun foam compact PUP 500 B2

The grey one-component gun foam in the compact can with high foam yield



Window connection joints



Closing joints in structural work

Applications

- Insulating and filling component joints, wall connections and wall penetrations
- Insulating and filling in roofing work and dry construction (e.g. in the ceiling area)
- Insulating and filling window connection joints, around window sills and shutter boxes
- Insulating and filling pipe penetrations and ventilation ducts

Building materials

Bonds to all standard building materials such as:

- Concrete
- Anodised layer
- Gypsum plasterboard
- Wood
- Sand-lime brick
- Plastics (not on PE, PP, Teflon, silicone)
- Masonry
- Metals with priming coat
- Plaster

Advantages

- The compact, handy can allows for use in difficult to access areas, and achieves a high degree of emptying without premature loss of gas.
- The grey colour of the foam is ideally suited to concrete substrates and allows for an inconspicuous filling of joints.
- The proven thermal protection and reduction of air permeability fulfil the high

- standards for modern thermal protection.
- The proven 61dB sound insulation fulfils the standards of modern sound insulation and helps to reduce noise.
- The new safety valve prevents adhesion when being stored horizontally or during long interruptions of work, thus guaranteeing long-lasting functionality.

12

Certificates

- General test certificate from building authorities P-NDS04-137
- Proven joint soundproofing $R(ST,w)=61$ (-1;-3) dB in line with ISO EN 717-1
- Proven thermal conductivity: Reduces heat loss by $0.0345 \text{ W}/(\text{m}^2\text{K})$
- Based on DIN 18542, proven airtightness of $a < 0.1 \text{ m}^3/[\text{h} \cdot \text{m}^2 \cdot (\text{daPa})^{2/3}]$
- EMICODE® EC 1 Plus - very low emission

Functioning

- 1-component PU foam
- Building material class B2
- Processing temperature environment: of $-5 \text{ }^\circ\text{C}$ to $+35 \text{ }^\circ\text{C}$ (can temperature: $+5 \text{ }^\circ\text{C}$ to $+20 \text{ }^\circ\text{C}$)
- Non-tacky after 8 - 12 minutes
- Can be cut after 40 - 60 minutes
- Hardened after 80 - 100 minutes
- Temperature resistant from $-40 \text{ }^\circ\text{C}$ to $+90 \text{ }^\circ\text{C}$
- Layer thicknesses $> 50 \text{ mm}$: foam in several layers and then dampen.
- Fresh foam stains can be removed immediately with fischer PU cleaner.

Technical data

1c premium gun foam compact PUP 500 B2					
Item	Item No.	Content per can [ml]	Max. foam yield (free foaming) [l]	Colour	Sales unit [pcs]
PUP 500 G B2	503259 ¹⁾	500	43	concrete grey	12

1) Dangerous goods - no express shipping possible.

1c gun foam PUP S 750 B2

The gun foam with proven joint sound-proofing, thermal insulation and water pressure resistance



Window connection joints



Filling pipe penetrations

Applications

- Insulating and filling window connection joints, around window sills and shutter boxes
- To insulate and fill wall penetrations, cavities, wall connections and finished elements
- To seal and bind well shafts, manhole shafts, domestic sewage treatment plants and cisterns

Advantages

- The proven 61dB sound insulation fulfills the standards of modern sound insulation and helps to reduce noise.
- The thermal protection and proven airtightness allows compliance with energy saving according to EnEV and substantiated as effective reduction of heat loss.
- External testing of watertightness when used in connection with hinged manhole

rings fulfils the requirements for a well foam.

- The low level foam expansion during the curing period avoids reworking, thus guaranteeing a simple and time-saving application.
- The new non-sticking safety valve guarantees long-lasting functionality.

Building materials

Bonds to all standard building materials such as:

- Concrete
- Anodised layer
- Fibre cement
- Gypsum plasterboard
- Wood
- Sand-lime brick
- Plastics (not on PE, PP, Teflon, silicone)
- Masonry
- Metals
- Plaster
- Stone

Certificates

- General test certificate from building authorities P-NDS04-137 for B2
- Proven joint soundproofing $R(ST,w)=61$ (-1;-3) dB in line with ISO EN 717-1
- Proven thermal conductivity: Reduces heat loss at $0.0345 \text{ W} / (\text{m} \cdot \text{K})$
- Based on DIN 18542 proven airtightness of $a < 0,1 \text{ m}^3 / [\text{h} \cdot \text{m}^2 (\text{daPa})^2 / 3]$
- Test for watertightness for the adhesion of manhole rings
- French VOC-emission class A+
- EMICODE® EC 1 Plus - very low emission

Functioning

- 1-component PU foam
- Building material class B2
- Processing temperature environment: $+5 \text{ }^\circ\text{C}$ to $+35 \text{ }^\circ\text{C}$ (can temperature: $+10 \text{ }^\circ\text{C}$ to $+30 \text{ }^\circ\text{C}$)
- Non-tacky after 8 - 12 minutes
- Cutting time 40 - 60 minutes
- Hardened after approx. 80 - 100 minutes
- Temperature resistant from $-40 \text{ }^\circ\text{C}$ to $+90 \text{ }^\circ\text{C}$
- Layer thicknesses $> 50 \text{ mm}$ foam in several layers and then dampen.
- Fresh foam stains can be removed immediately with fischer PU cleaner.

Technical data

1c gun foam PUP S 750 B2

Item	Item No.	Content per can [ml]	Max. foam yield (free foaming) [l]	Colour	Sales unit [pcs]
PUP S 750 B2 (DE)	539197 ¹⁾²⁾	750	50	beige	12
PUP S 750 B2 (DE)	040302 ¹⁾	750	50	beige	12

1) Dangerous goods - no express shipping possible.

2) Without protective gloves, for commercial users only.

1c maxi gun foam PUP S 500 B2

The proven sound and thermal insulation foam with higher foam yield for professionals in a short can

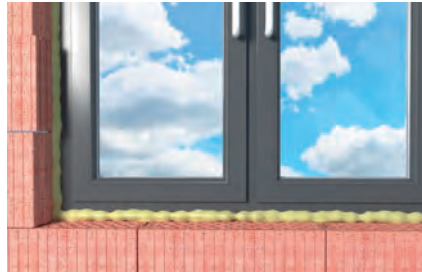

Window connection joints



Closing joints in structural work

Applications

- Insulating and filling window connection joints, around window sills and shutter boxes
- Insulating and filling finished elements, wall connections, wall penetrations and cavities
- Insulating and filling in roofing work and dry construction (e.g. in the ceiling area)
- Insulating and filling pipe penetrations and ventilation ducts

Building materials

Bonds to all standard building materials such as:

- Concrete
- Anodised layer
- Gypsum plasterboard
- Wood
- Sand-lime brick
- Plastics (not on PE, PP, Teflon, silicone)
- Masonry
- Metals with priming coat
- Plaster

Technical data

1c maxi gun foam PUP S 500 B2					
Item	Item No.	Content per can [ml]	Max. foam yield (free foaming) [l]	Colour	Sales unit [pcs]
PUP S 500 MAXI B2 (DE)	539163 ¹⁾²⁾	500	43	beige	12

1) Dangerous goods - no express shipping possible.

2) Without protective gloves, for commercial users only.

Advantages

- The short, handy can allows the correct positioning in awkward places and leads without premature gas loss to a high emptying of residues.
- The low level of foam expansion during the curing period avoids reworking, thus guaranteeing a simple and time-saving

application.

- The thermal protection and proven airtightness allows compliance with energy saving according to EnEV and substantiated as effective reduction of heat loss.
- The high joint soundproofing of 61dB fulfils the standards of modern sound insulation and helps to reduce noise.

12

Certificates

- General test certificate from building authorities P-NDS04-137 für B2
- Proven joint soundproofing: $R(ST,w)=61$ (-1;-3) dB in line with ISO EN 717-1
- Proven thermal conductivity: Reduces heat loss at 0.0345 W/(m * K)
- Based on DIN 18542 proven airtightness of $a < 0,1 \text{ m}^3/[\text{h} \cdot \text{m}^3 \cdot (\text{daPa})^2/3]$
- French VOC-emission class A+
- EMICODE® EC 1 Plus - very low emission

Functioning

- 1-component PU foam
- Building material class B2
- Low post-expansion
- Processing temperature environment: $\pm 0 \text{ }^\circ\text{C}$ to $+35 \text{ }^\circ\text{C}$ (can temperature: $+5 \text{ }^\circ\text{C}$ to $+20 \text{ }^\circ\text{C}$)
- Non-tacky after 8 - 12 minutes
- Can be cut after 40 - 60 minutes
- Hardened after 80 - 100 minutes
- Temperature resistant from $-40 \text{ }^\circ\text{C}$ to $+90 \text{ }^\circ\text{C}$
- Fresh foam stains can be removed immediately with fischer PU cleaner.

1c premium gun foam PUP 750 B3

The one-component gun foam with the perfect dosage



Window connection joints



Connection joints around shutter boxes

Applications

- Insulating and filling window connection joints, around window sills and shutter boxes
- Insulating and filling in roofing work and dry construction
- Insulating and filling finished elements, wall connections, wall penetrations and cavities
- Insulating and filling pipe penetrations and ventilation ducts

Advantages

- The low level of foam expansion during the curing period avoids reworking, thus guaranteeing a simple and time-saving application.
- The easy dosage allows for a controlled filling and sealing, and ensures that the

- correct amount is used.
- The proven 60dB sound insulation fulfils the standards of modern sound insulation and helps to reduce noise.
- The new non-sticking safety valve guarantees long-lasting functionality.

Building materials

Bonds to all standard building materials such as:

- Concrete
- Anodised layer
- Gypsum plasterboard
- Wood
- Sand-lime brick
- Plastics (not on PE, PP, Teflon, silicone)
- Masonry
- Metals with priming coat
- Plaster

Certificates

- Proven joint soundproofing $R(ST,w)=60$ (-1;-4) dB in line with ISO EN 717-1
- EMICODE® EC 1 Plus - very low emission

Functioning

- 1-component PU foam
- Building material class B3
- Processing temperature environment: +5 °C to +35 °C (can temperature: +10 °C to +30 °C)
- Non-tacky after approx. 15 minutes
- Can be cut after approx. 45 minutes
- Cures within 5 to 8 hours
- Temperature resistant from -40 °C to +90 °C
- Layer thicknesses > 50 mm: foam in several layers and then dampen.
- Fresh foam stains can be removed immediately with fischer PU cleaner.

Technical data

1c premium gun foam PUP 750 B3

Item	Item No.	Content per can [ml]	Max. foam yield (free foaming) [l]	Colour	Sales unit [pcs]
PUP 750 B3 GunGrade (EN/FR)	098012 ¹⁾	750	41	beige	12

¹⁾ Dangerous goods - no express shipping possible.

1c premium gun foam PUP B1 750

The hardly flammable B1 one-component gun foam

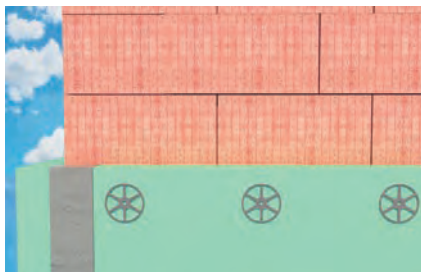

Filling cavities in the insulation



Foaming steel door frames

Applications

- High-efficiency thermal insulation on façades
- Insulating and filling in roofing work
- Insulating and filling window connection joints, around window sills and shutter boxes
- Insulating and filling finished elements, wall connections, wall penetrations and cavities

Building materials

Bonds to all standard building materials such as:

- Concrete
- Anodised layer
- Gypsum plasterboard
- Wood
- Sand-lime brick
- Plastics (not on PE, PP, Teflon, silicone)
- Masonry
- Metals with priming coat
- Plaster

Advantages

- The PUFS is hardly flammable in line with the B1 test and can therefore be used between solid, mineral or metal building materials. Thus it provides the highest level of safety.
- The new high-quality safety valve prevents adhesion when being stored

horizontally or during long interruptions of work, thus guaranteeing long-lasting functionality.

- The easy dosage allows for a controlled filling and sealing, and ensures that the correct amount is used.

Certificates

- General test certificate from building authorities P-NDS04-620
- Proven joint soundproofing: of 10 and 20 mm joint width: $R_{s,w} (C; Ctr) \geq 63$ (-2;-5) dB
- French VOC-emission class A+

Functioning

- 1-component PU foam
- Building material class B1
- Foam yield of extruded foam 45 l
- Processing temperature environment: +10 °C to +25 °C (can temperature: +10 °C to +25 °C)
- Non-tacky after approx. 10 minutes
- Can be cut after approx. 40 minutes
- Cures within 5 to 8 hours
- Temperature resistant from -40 °C to +90 °C
- Layer thicknesses > 50 mm: foam in several layers and then dampen.
- Fresh foam stains can be removed immediately with fischer PU cleaner.

Technical data

1c premium gun foam PUP B1 750					
Item	Item No.	Content per can [ml]	Max. foam yield (free foaming) [l]	Colour	Sales unit [pcs]
PUP B1 750 (DE/EN)	045300 ¹⁾	750	45	concrete grey	12

¹⁾ Dangerous goods - no express shipping possible.

1c premium gun foam PUP BS 750 B2

The one-component gun foam with proven resistance to water pressure



Sealing concrete manhole rings



Filling pipe penetrations

Applications

- To quickly fill joints between hinged manhole rings
- To seal and bind well shafts, manhole shafts, domestic sewage treatment plants and cisterns
- To insulate and fill wall penetrations, cavities, wall connections and finished elements

Advantages

- External testing of watertightness when used in connection with hinged manhole rings fulfils the requirements for a well foam.
- The special foam is ready and easy to use, and replaces the time- and work-intensive application of mortar.
- The high resistance to dilute chemicals and mineral oil, the resistance to

acids and bacteria found in soil, and the resistance to rot all guarantee a lasting function.

- The easy dosage allows for a controlled filling and sealing, and ensures that the correct amount is used.
- The new non-sticking safety valve guarantees long-lasting functionality.

Building materials

Bonds to all standard building materials such as:

- Concrete
- Anodised layer
- Fibre cement
- Gypsum plasterboard
- Wood
- Sand-lime brick
- Plastics (not on PE, PP, Teflon, silicone)
- Masonry
- Metals with priming coat
- Plaster
- Stone

Certificates

- General test certificate from building authorities P-NDS04-137
- Test for watertightness up to 0.5 bar for the adhesion of manhole rings
- Proven joint soundproofing: $R(ST,w)=61$ (-1;-3) dB in line with ISO EN 717-1
- Proven thermal conductivity: Reduces heat loss by $0.0345 \text{ W}/(\text{m}^2\text{K})$
- Based on DIN 18542, proven airtightness of $a < 0.1 \text{ m}^3/[\text{h}^* \text{m}^2(\text{daPa})^{2/3}]$
- French VOC-emission class A+

Functioning

- 1-component PU foam
- Building material class B2
- Processing temperature environment: $+5 \text{ }^\circ\text{C}$ to $+35 \text{ }^\circ\text{C}$ (can temperature: $+10 \text{ }^\circ\text{C}$ to $+30 \text{ }^\circ\text{C}$)
- Non-tacky after 8 - 12 minutes
- Bind manholes together before skin formation.
- Do not cut or spread foam coming from the hinge.
- Hardened after 80 - 100 minutes
- Temperature resistant from $-40 \text{ }^\circ\text{C}$ to $+90 \text{ }^\circ\text{C}$
- Layer thicknesses $> 50 \text{ mm}$ foam in several layers and then dampen.
- Fresh foam stains can be removed immediately with Fischer PU cleaner.

Technical data

1c premium gun foam PUP BS 750 B2

Item	Item No.	Content per can [ml]	Max. foam yield (free foaming) [l]	Colour	Sales unit [pcs]
PUBS 750 B2	513763 ¹⁾	750	50	beige	12

1) Dangerous goods - no express shipping possible.

1c perimeter adhesive foam PUP P 750

The economic adhesive one-component foam for perimeter insulation boards



Bonding perimeter insulation boards



Filling pipe penetrations

Applications

- Bonding expanded polystyrene panels
- Insulating and filling wall penetrations
- Foaming in electrical installations
- Filling joints and cavities in all internal constructions
- Fixing and sealing walls and ceilings

Building materials

- Concrete
- Bitumen coatings
- Anodised layer
- Gypsum plasterboard
- Wood
- Cold bitumen sheeting
- Plastics (not on PE, PP, Teflon, silicone)
- Masonry
- Metals with priming coat
- Plaster

Advantages

- The high foam yield allows for the bonding of approx. 13 m² of wall space, and is therefore especially economical.
- The use of the can/gun system provides a time saving of approx. 30% and thus guarantees efficient work.
- The special PU foam formulation ensures the best adhesion to concrete and

- bituminous substrates, and allows for the long-term fixing of insulation boards.
- The very low level of post-expansion avoids the formation of cavities and guarantees a long-lasting insulation.
- The new non-sticking safety valve guarantees long-lasting functionality.

Certificates

- General test certificate from building authorities P-NDS04-772
- French VOC-emission class A+
- EMICODE® EC 1 Plus - very low emission

Functioning

- 1-component PU foam
- Building material class B2
- Processing temperature environment: +10 °C to +25 °C (can temperature: +5 °C to +25 °C)
- Non-tacky after approx. 10 minutes
- Can be cut after approx. 40 minutes
- Temperature resistant from -40 °C to +90 °C
- Low heat conductivity
- Apply a min. of 3 end-to-end stripes per board, vertically from bottom to top on the external wall (spacing approx. 30 cm). The bottom board should be on fixed ground as protection from later slipping. After approx. 10 minutes apply the boards onto the holding surface and press hard.
- Fresh foam stains can be removed immediately with fischer PU cleaner.

Technical data

1c perimeter adhesive foam PUP P 750					
Item	Item No.	Content per can [ml]	Max. foam yield (free foaming) [l]	Colour	Sales unit [pcs]
PUP P 750 G B2	506671 ¹⁾	750	45	concrete grey	12

1) Dangerous goods - no express shipping possible.

1c adhesive foam PUP ETICS 750

The adhesive one-component foam for ETIC systems with general technical approval



Insulation of cellar ceiling



Wall insulation

Applications

- Bonding of EPS rigid foam panels in accordance with ETAG Guideline 004/2013
- Fixing of external wall insulation, internal wall insulation and attic insulation
- Fixing of basement ceiling insulation
- Bonding of perimeter insulation panels

Building materials

- EPS-insulation panels
- Concrete
- Bitumen coatings
- Anodised layer
- Gypsum plasterboard
- Wood
- Cold bitumen sheeting
- Plastics (not on PE, PP, Teflon, silicone)
- Masonry
- Metals with priming coat
- Plaster

Advantages

- The special recipe guarantees high adhesive tensile strength for secure fixing.
- The high foam yield allows for the bonding of up to 12 m² of wall space and is therefore especially economical.
- Really low post-expansion avoids the formation of cavities between the wall and

insulation panel and guarantees a secure connection.

- The use of the can/gun system provides a time saving of approx. 30% and thus guarantees efficient work.
- The new non-sticking safety valve guarantees long-lasting functionality.

Certificates

- Building approval for bonding EPS boards in ETIC systems
- Adhesive tensile strength values (based on ETAG guideline 004/2013, section 5.1.4.1.2)
- French VOC-emission class A+

Functioning

- 1-component PU foam
- Foam yield sufficient for up to 12 m² wall area
- Processing temperature environment: +5 °C to +25 °C (can temperature: +10 °C to +25 °C)
- Open Time approx. 10 minutes
- Can be cut after approx. 20 minutes
- Temperature resistant from -40 °C to +90 °C
- Extremely high heat insulation properties
- Shear resistance (EN 12090) 38,7 kPa
- Fresh foam stains can be removed immediately with fischer PU cleaner.
- When pressed on, an adhesive surface percentage of at least 40% must be achieved.
- Do not knock the insulation panels against the wall (this damages the foam structure).

Technical data

1c adhesive foam PUP ETICS 750

Item	Item No.	Content per can [ml]	Max. foam yield [m ²]	Colour	Sales unit [pcs]
PUP WDVS 750 Premium	539164 ¹⁾	750	up to 12	light green	12
PUP 750 ETICS (EN)	543448 ¹⁾	750	up to 12	light green	12

¹⁾ Dangerous goods - no express shipping possible.

2c premium rapid foam 2K PU 400 Plus

The high-quality 2c rapid foam for fast and secure fixation with optimized activation system



Foaming door frames



Foaming below bath tubs

Applications

- For mounting door frames made of wood, plastic and steel (DIN 18111 T4) and window frames
- Filling and insulating of cavities in walls and ceilings with insufficient moisture access
- Assembly of foamed PS moulded parts, shower trays and bathtubs (tub support assembly foam)
- Fixing insulating elements, wooden cladding, sheet metal panels, control boxes

Building materials

Bonds to all standard building materials such as:

- Concrete
- Anodised layer
- Gypsum plasterboard
- Wood
- Sand-lime brick
- Plastics (not on PE, PP, Teflon, silicone)
- Masonry
- Metals with priming coat
- Plaster

Technical data

2c premium rapid foam 2K PU 400 Plus

Item	Item No.	Content per can [ml]	Max. foam yield (free foaming) [l]	Colour	Sales unit [pcs]
2K PU 400 PLUS B2 (DE)	053081 ¹⁾	400	10	light blue	12

1) Dangerous goods - no express shipping possible.

Advantages

- The high dimensional stability certified by the independent ift Rosenheim institute provides security and saves additional costs, as time-consuming reworking of door frames is avoided.
- The newly developed activation system guarantees a 100% fail-safe opening of the inner activator container and thus avoids disturbances during hardening and thus subsequent pressing or shrinkage.
- The externally determined, very high

sound insulation value of 63 dB makes a major contribution to effective noise protection and leads to an increase in well-being.

- The non-adhesive safety valve prevents inoperability in horizontal storage and premature gas loss.
- The high shear strength of the PU foam ensures a secure and durable fastening of the door frame.

Certificates

- General test certificate from building authorities P-NDS04-666
- Evidence of dimensional stability certified by the ift Rosenheim
- Proven joint soundproofing for 10 and 20 mm joints: $R_{s,w} (C; C_{tr}) \geq 63 (-2; -5) \text{ dB}$
- French VOC emission class A+
- EMICODE® EC 1 Plus - very low emission

Functioning

- 2-component PU foam
- Building material class B2
- Foam yield of extruded foam 10 l
- Can and processing temperature: +15 °C to +25 °C (optimal: +20 °C; substrate temperature: min. +10 °C)
- Non-tacky after approx. 6 minutes
- Can be cut after approx. 10 minutes
- Cures after approx. 30 minutes
- Can be despread after 60 minutes (+20 °C)
- Temperature resistant from -40 °C to +90 °C
- Fresh foam stains can be removed immediately with fischer PU cleaner.

PUP K2 Plus



Advantages

- The light construction facilitates use on construction sites and allows for fatigue-free work.
- The impact-requiring control prevents the unintentional unscrewing of the regulating screw, and is therefore particularly user-friendly.
- The gun adapter is suitable for all standard systems and enables universal application.
- Opened cans can remain screwed onto the gun during interruptions of work without curing.

PUP M3



Advantages

- The PUP M3 meets the tough requirements of a construction site and thus offers a long lifespan.
- The ergonomic handle allows for an ideal position of centre of gravity, and therefore precise handling.
- The infinitely variable control of the foam expulsion allows for a controlled filling and insulating, and enables application-orientated work.
- Opened cans can remain screwed onto the gun during interruptions of work without curing.

PUP M4 BLACK



Advantages

- The complete PTFE coating reduces cleaning to a minimum.
- Non-return ball and basket are coated with PTFE. This prevents bonding and guarantees a long-lasting function.
- The perfect combination of the ergonomically shaped handle and trigger makes handling particularly user-friendly.
- The tubes included with the 19 cm long, tapered pistol pipe mean that it can be individually lengthened for use in the narrowest joints, thus offering a high degree of flexibility.

Technical data

Application devices		
Item	Item No.	Sales unit [pcs]
PUP K2 PLUS	062400	1
PUP M3	033208	1
PUP M4 BLACK	513429	1

PU-cleaner



Advantages

- The active components ensure a high cleaning effect, making the cleaner ideal for the safe removal of fresh PU foam.
- The gun adapter is suitable for all standard systems and enables universal application.
- The separate spray head allows for the cleaning of external surfaces, making the product extremely versatile.
- The highly active cleaner can etch sensitive surfaces (paint, dye, textiles, plastics). Thus you should always conduct preliminary tests.

Technical data

PU-cleaner			
Item	Item No.	Contents [ml]	Sales unit [pcs]
PUR 150 (DE)	053083 ¹⁾	150	12
PUR 500 (DE/EN)	053085 ¹⁾	500	12

¹⁾ Dangerous goods - no express shipping possible.

Example of use for sealants





- 1** DSSA Premium sanitary silicone
- 2** DHS Premium high temperature silicone
- 3** DBSA Premium construction silicone
- 4** DBSI Roof and wall silicone
- 4** DNS Premium silicone 1 For All
- 5** DFS Premium B1 silicone
- 6** DMA Premium painting acrylic
- 7** DA Acrylic sealant
- 8** DSA Premium structured acrylic
- 9** DFA Premium acrylic sealant facade
- 10** DDK Premium all-weather sealant
- 11** DD Roof sealing compound

Sealant selection matrix











Sealant selection matrix																											
	Chem. basis	ABS/Polystyrene	Acrylic glass (Macrolon, perspex etc.)	Acrylic tubs (sanitary acrylic)	Aluminium	Concrete	Concrete block	Bitumen	Non ferrous heavy metal (copper, brass)	Stainless steel	Sandblasted iron	Enamel	Tiles	Gypsum/gypsum plasterboard	Glass	Hard PVC	Wood	Ceramics	Natural stone/marble	Polyester	Aircrete	Plaster	Resopal	Stoneware	Brick/clinker brick	Zinc/galvanizing	
• suitable T requires test - not suitable																											
DSSA Premium sanitary silicone	Silicone acetate	•	-	•	•	-	-	-	-	•	-	•	•	-	•	•	•	•	-	•	-	-	•	•	-	-	
DSSI Sanitary silicone	Silicone acetate	-	-	•	•	-	-	-	-	•	-	•	•	-	•	•	•	•	-	•	-	-	•	•	-	-	
DMS Multi-silicone	Silicone acetate	•	-	T	•	-	-	-	-	•	-	•	•	-	•	-	•	•	-	•	-	-	•	•	-	-	
DHS Premium high temperature silicon	Silicone acetate	•	-	-	•	T	-	-	T	•	-	•	•	T	•	-	•	•	-	•	T	T	•	•	T	T	
DBSA Premium construction silicone	Silicone alkoxy	•	•	T	•	•	-	-	•	•	•	•	•	•	•	•	•	•	-	•	•	•	•	•	•	•	
DBSI Roof and wall silicone	Silicone oxime	•	-	•	•	•	-	-	•	•	•	•	•	•	•	•	•	•	-	•	•	•	•	•	•	•	
DNS Premium Silicone 1 For All	Silicone oxime	•	-	•	•	•	•	-	•	•	•	•	•	•	•	•	•	•	•	•	•	•	•	•	•	•	
DFS Premium B1 silicone	Silicone oxime	•	•	•	•	•	-	-	•	•	•	•	•	•	•	•	•	•	-	•	•	•	•	•	•	•	
DKM Construction sealant Premium	Hybride	T	• ¹⁾	•	•	•	-	-	•	•	•	•	•	•	•	•	•	•	-	•	•	•	•	•	•	•	
DFA Facade acrylic Premium	Dispersion acrylic	-	-	-	•	•	-	-	•	•	-	•	•	•	-	•	•	•	-	•	•	•	•	•	•	•	
DMA Premium painting acrylic	Dispersion acrylic	-	-	-	•	•	-	-	•	•	-	•	•	•	-	•	•	•	-	•	•	•	•	•	•	•	
DSA Premium structured acrylic	Dispersion acrylic	-	-	-	•	•	-	-	•	-	-	•	•	-	T	•	T	-	•	•	•	•	•	•	•	•	
DA Acrylic Sealant	Dispersion acrylic	-	-	-	•	•	-	-	•	-	-	•	T	-	-	•	T	-	•	•	•	•	•	•	•	T	
DDK Premium all-weather sealant	Synthetic rubber	•	-	-	•	•	-	•	•	•	-	•	-	-	•	•	•	-	•	•	•	•	•	•	•	•	
DD Roof sealing compound	Bitumen	-	-	-	•	•	-	•	•	•	-	•	-	-	-	•	•	-	•	-	-	T	-	•	•	•	

¹⁾ perspex not







Note: Avoid direct contact between the silicone and bituminous or plasticiser materials (e.g. EPDM, butyl, neoprene). The written and spoken information contained in this technical datasheet and our practical support is provided to the best of our knowledge and does not represent binding information or guarantees as described in § 443 of the German Civil Code. We recommend that you test the suitability of our products for the intended application prior to use. Due to the diverse range of applications of the individual product and the unpredictable conditions on site, we also recommend testing the adhesion prior to use.

Sealant colour board

DSSA Premium sanitary silicone

										
Art.-No. 53100 transparent	Art.-No. 53101 white	Art.-No. 53103 bahama beige	Art.-No. 58530 silver grey	Art.-No. 512208 joint grey	Art.-No. 53102 grey	Art.-No. 512209 sanitary grey	Art.-No. 512210 manhattan	Art.-No. 53105 dark grey	Art.-No. 512211 anthracite	Art.-No. 53120 black

DBSA Construction silicone

						
Art.-No. 53090 transparent	Art.-No. 53091 white	Art.-No. 53095 beige	Art.-No. 53092 concrete grey	Art.-No. 53093 brown	Art.-No. 512213 slate grey	Art.-No. 53094 black



DHS Premium high temperature silicone

Art.-No. 53125 reddish brown

DFS Premium B1 silicone

Art.-No. 53131 grey

DA Acrylic sealant

		
Art.-No. 53110 white	Art.-No. 53111 grey	Art.-No. 53112 brown

Premium sanitary silicone DSSA

The high-quality premium sanitary silicone



Joints in sanitary areas



Sealings in the kitchen

Applications

- Corner, movement and connection joints in sanitary areas (sinks, showers, bath tubs, expansion joints between tiles etc.)
- Connection joints in the kitchen
- Window and glass sealings
- Seal welds for display cabinets and glass blocks
- Small-scale adhesions (e.g. window bars)

Building materials

- Chrome
- Stainless steel
- Anodised layer
- Enamel, Tiles
- Glass, glazed surfaces
- Wood (with primer)
- H-PVC
- Ceramics
- Polyester
- Sanitary acrylic

Advantages

- The high-quality formulation allows for easy application and smoothing, and ensures efficient work.
- The outstanding movement capacity means that DSSA is ideal for high-stress expansion joints. This guarantees long-lasting jointing.
- The very good hold on smooth surfaces

Certificates

- EN 15651 - Part 1: F-EXT-INT-CC (25LM)
- EN 15651 - Part 2: G-CC (25LM)
- EN 15651 - Part 3: S (XS1)
- French VOC-emission class A+

prevents damp from forming in the substrate and guarantees reliable functioning.

- The high wear resistance gives the surface a high level of protection when cleaning. Together with the long-term mold protection, an ideal jointing can be achieved that will last over the long term.

Functioning

- Chemical base: 1-component silicone acetate
- Permanently elastic
- With fungicide
- Skin formation time: approx. 10 minutes
- Processing temperature: +5 °C to +40 °C
- Temperature resistance: -40 °C to +180 °C
- Good chemical resistance
- Very good resistance to weather, ageing and UV
- Compatible with paint
- Not paintable
- Free of MDI and solvents
- Selection table for substrates - refer to page 570

Technical data

Premium sanitary silicone DSSA				
Item	Item No.	Colour	Contents [ml]	Sales unit [pcs]
DSSA TP (DE/EN)	053100	transparent	310	12
DSSA W (DE/EN)	053101	white	310	12
DSSA GR (DE/EN)	053102	grey	310	12
DSSA BG (DE/EN)	053103	bahama beige	310	12
DSSA DG (DE/EN)	053105	dark grey	310	12
DSSA SW (DE/EN)	053120	black	310	12
DSSA SG (DE/EN)	058530	silver grey	310	12
DSSA FUG (DE/EN)	512208	joint grey	310	12
DSSA SAG (DE/EN)	512209	sanitary grey	310	12
DSSA MA (DE/EN)	512210	manhattan	310	12
DSSA AN (DE/EN)	512211	anthracite	310	12

Sanitary silicone DSSI

The standard sanitary silicone



Joints in sanitary areas



Wash basins

Applications

- Joints in sinks and toilets
- Expansion joints between floor and wall tiles
- Joints around enamel and plastic showers and bath tubs
- Connection joints between timber and tiles
- Connection joints in the kitchen
- Seal welds for display cabinets and glass blocks
- Glazing wood and aluminium windows

Advantages

- The 20% elasticity means that DSSI is ideal for expansion and connection joints. This guarantees long-lasting jointing.
- The very good hold on smooth surfaces, e.g. tiles, prevents damp forming in

- the substrate and guarantees reliable functioning.
- The fungicidal properties ensure a clean look over the long term.

Building materials

- Stainless steel
- Anodised layer
- Epoxy
- Tiles
- Glazed surfaces
- Glass
- H-PVC
- Ceramics
- Painted wood
- Polyester

Certificates

- EN 15651 - Part 1: F EXT-INT-CC
- EN 15651 - Part 3: S

Functioning

- Chemical base: 1-component silicone acetate
- Permanently elastic
- With fungicide
- Skin formation time: approx. 10 to 15 minutes
- Processing temperature: +5 °C to +40 °C
- Temperature resistance: -40 °C to +150 °C
- Shore-A hardness 25
- 100% Modulus 0.4 N/mm²
- Elongation at break 450%
- Good chemical resistance
- Very good resistance to weather, ageing and UV
- Not paintable
- Selection table for substrates - refer to page 570

Technical data

Sanitary silicone DSSI				
Item	Item No.	Colour	Contents [ml]	Sales unit [pcs]
DSSI TP (EN/FR/AR)	058515	transparent	280	24
DSSI W (EN/FR/AR)	058516	white	280	24

Multi-silicone DMS

The silicone sealant with an acetate base for internal and external applications



Joints in sanitary areas



Sealings in the kitchen

Applications

- Bathrooms, showers and toilets
- Connection joints to sinks
- Expansion joints between tiles
- Connection joints in the kitchen
- Joints between timber and tiles
- Seal welds for display cabinets and glass blocks

Building materials

- Stainless steel
- Anodised layer
- Epoxy
- Tiles
- Glazed surfaces
- Glass
- H-PVC
- Ceramics
- Painted wood
- Polyester

Advantages

- Thanks to the practical elasticity of 20%, DMS is ideally suited to connection joints with expansion. This guarantees long-lasting jointing.
- The fungicidal properties ensure a clean look over the long term.
- The very good hold on smooth surfaces

Certificates

- EN 15651 - Part 1: F EXT-INT-CC
- EN 15651 - Part 3: S

prevents damp from forming in the substrate and guarantees reliable functioning.

- The good resistance to UV, weathering and ageing means that DMS can be used both indoors and outdoors, and offers a high level of security over the long term.

Functioning

- Chemical base: 1-component silicone acetate
- Permanently elastic
- With fungicide
- Skin formation time: approx. 10 to 15 minutes
- Processing temperature: +5 °C to +40 °C
- Temperature resistance: -40 °C to +150 °C
- Shore-A hardness 25
- 100% Modulus 0.4 N/mm²
- Elongation at break 450%
- Very good resistance to weather, ageing and UV
- Not paintable
- Selection table for substrates - refer to page 570

12

Technical data

Multi-silicone DMS				
Item	Item No.	Colour	Contents [ml]	Sales unit [pcs]
DMS TP (GB/E)	040385	transparent	280	24
DMS W (GB/E)	040386	white	280	24
DMS GR (GB/E)	040389	grey	280	24
DMS SW (GB/E)	504413	black	280	24

Premium high temperature silicone DHS

The silicone sealant for high temperature requirements



Sealing fireplaces



Sealing cookers

Applications

- Sealing of joints around cookers, ovens and fireplaces
- Sealing of joints around boilers and industrial furnaces
- Sealing of joints around pipes and channels subjected to high temperatures
- Sealing of ventilation grilles
- Sealing of air conditioning units

Advantages

- The high temperature resistance of up to +300°C means that DHS can be used for joints with increased thermal load.
- Meanwhile, the high resistance to chemicals also allows for use in areas subjected to chemical loads, thus offering a high level of application safety.
- The very good adhesion to smooth

surfaces allows for the components to be completely sealed. This allows for reliable functioning.

- DHS is easy to apply and smooth out. This allows for efficient work, and helps to guarantee a simple and time-saving application.

Functioning

- Chemical base: 1-component silicone acetate
- Permanently elastic
- Skin formation time: approx. 10 to 15 minutes
- Processing temperature: +5 °C to +40 °C
- Temperature resistance: -40 °C to +300 °C
- Shore-A hardness 25
- Very good resistance to chemicals
- Very good resistance to weather, ageing and UV
- Not paintable
- Free of MDI and solvents
- Selection table for substrates - refer to page 570

Technical data

Premium high temperature silicone DHS

Item	Item No.	Colour	Contents [ml]	Sales unit [pcs]
DHS RB (DE/EN)	053125	reddish brown	310	12

Premium construction silicone DBSA

The low-odour premium construction silicone with high adhesive spectrum



External connection joints

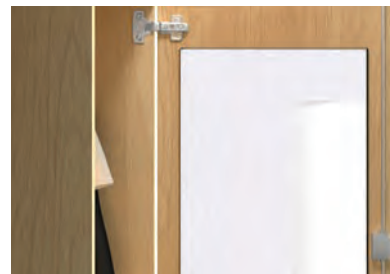

Fixing mirrors

Applications

- Connection and expansion joints in the construction industry (e.g. windows, doors, façades, light domes)
- Window glazing
- Movement and connection joints in kitchens, sanitary areas and installations
- Fixing mirrors (transparent version)
- Sealing machines, containers and building apparatus

Building materials

- Concrete
- Chrome
- Stainless steel
- Anodised layer
- Enamel, Tiles, Ceramics
- Glass, glazed surfaces
- Wood (with primer)
- H-PVC
- Copper, brass
- Masonry
- PMMA, PC, Polyester
- Steel
- Zinc

Advantages

- The high-quality, neutral silicone sealant with a very low volume shrinkage is suitable for demanding applications in construction and the industrial sector, and guarantees a high degree of functional safety.
- DBSA is low-odour and is therefore ideal

- for use in confined spaces.
- The silicone is easy to apply and smooth out, thus allowing for efficient work and a simple and time-saving jointing.
- The high wear resistance gives the surface a high level of protection when cleaning and thus ensures a perfect look over a long period.

12

Certificates

- EN 15651 - Part 1: F-EXT-INT-CC (25LM)
- EN 15651 - Part 2: G-CC (25LM)
- EN 15651 - Part 3: S (XS1)
- French VOC-emission class A+

Functioning

- Chemical base: 1-component silicone neutral alkoxy
- Fulfils DIN EN ISO 11600 F+G 25
- Permanently elastic
- Low-odour
- With fungicide
- Skin formation time: 10 to 15 min
- Processing temperature: +5 °C to +40 °C
- Temperature resistance: -40 °C to +150 °C
- Shore-A hardness approx. 25
- Permitted overall deformation: 25%
- Non-corrosive
- Very good resistance to weather, ageing and UV
- Compatible with paint
- Not paintable
- Resistant to wear and streak-free
- Selection table for substrates - refer to page 570

Technical data

Premium construction silicone DBSA				
Item	Item No.	Colour	Contents [ml]	Sales unit [pcs]
DBSA BG (DE/EN)	053095	beige	310	12
DBSA SLG (DE/EN)	512213	slate grey	310	12
DBSA SW (DE/EN)	053094	black	310	12
DBSA TP (DE/EN)	053090	transparent	310	12
DBSA W (DE/EN)	053091	white	310	12
DBSA GR (DE/EN)	053092	concrete grey	310	12
DBSA BR (DE/EN)	053093	brown	310	12

Roof and wall silicone DBSI

The versatile construction silicone



External connection joints



Joints between buildings

Applications

- Connection and expansion joints in the construction industry (e.g. windows, doors, façades, light domes)
- Connection joints on windows and doors
- Sealing façades, curtain walling panels and metal structures
- Movement and connection joints in kitchens, sanitary areas and installations

Building materials

- Concrete
- Chrome
- Stainless steel
- Anodised layer
- Enamel
- Epoxy
- Tiles
- Glass, glazed surfaces
- Wood (with primer)
- H-PVC
- Ceramics
- Copper
- Masonry
- Brass
- Polyester
- Steel
- Zinc

Advantages

- The neutral silicone sealant is suitable for various applications in construction and the industrial sector, and thus offers a high level of flexibility.
- The high movement capacity means that DBSI is ideal for expansion joints. This

- guarantees long-lasting jointing.
- DBSI is non-corrosive and is therefore well suited to copper and zinc-plated surfaces. Thus it can be used without problems in the metal processing industry.

12

Certificates

- EN 15651 - Part 1: F-EXT-INT-CC
- EN 15651 - Part 2: G-CC
- EN 15651 - Part 3: S

Functioning

- Chemical base: 1-component silicone neutral oxime
- Permanently elastic
- With fungicide
- Skin formation time: 10 to 15 minutes
- Processing temperature: +5 °C to +40 °C
- Temperature resistance: -40 °C to +180 °C
- Shore-A hardness 18±3
- Non-corrosive
- Very good resistance to weather, ageing and UV
- Compatible with paint
- Not paintable
- Selection table for substrates - refer to page 570

Technical data

Roof and wall silicone DBSI				
Item	Item No.	Colour	Contents [ml]	Sales unit [pcs]
DBSI TP (DE/EN)	094417	transparent	310	12

Premium silicone 1 For All DNS

The high performance silicone even for marble and natural stone



Joints on natural stone panels



Joints on tiles and natural stone and marble panels

Applications

- Sealing and jointing marble and natural stone for internal and external use
- Joints in sanitary areas
- Joints in façade construction
- Joints in the glazing
- Joints in the flooring
- Corner joints in floors and walls
- Movement-compensating adhesion of natural stone onto metal structures (e.g. stair treads)

Building materials

- Marble
- Natural stone (e.g. granite, porphyry, quartzite, sandstone)

Also suitable for:

- Concrete
- Stainless steel
- Anodised layer
- Tiles, Ceramics
- Glass
- Wood (with primer)
- H-PVC
- Copper
- Masonry
- Sanitary acrylic
- Steel
- Zinc

Advantages

- The specially adapted formulation prevents edge soiling and gives a lasting clean look, particularly for natural stone and marble.
- With 10 years warranty on UV-, weather- and aging resistance for maximum durability.
- The outstanding movement capacity

means that DNS is ideal for highstress expansion joints. This guarantees long-lasting jointing.

- Fungicidal agent prevents mildew formation and ensures a clean look over the long term.

Certificates

- EN 15651 - Part 1: F-EXT-INT-CC (25LM)
- EN 15651 - Part 2: G-CC (25LM)
- EN 15651 - Part 3: S (XS1)
- EN 15651 - Part 4: PW-EXT-INT-CC (25LM)
- French VOC-emission class A+

Functioning

- Chemical base: 1-component silicone neutral curing
- Permanently elastic
- Low-odour
- With fungicide
- Skin formation time approx. 15 minutes
- Processing temperature: +5 °C to +40 °C
- Temperature resistance: -40 °C to +180 °C
- Shore-A hardness 25
- Non-corrosive
- Good chemical resistance
- Very good resistance to weather, ageing and UV
- Compatible with paint
- Not paintable
- Selection table for substrates - refer to page 570

Technical data

Premium silicone 1 For All DNS				
Item	Item No.	Colour	Contents [ml]	Sales unit [pcs]
DNS TP (DE/EN)	053121	transparent	310	12

Premium B1 silicone DFS

The hardly flammable silicone sealant



Joints on fire protection doors



Sealings in public buildings

Applications

- Sealing connection and expansion joints that are required to have a fire-resistant effect against the spreading of fire, water, smoke and poisonous fumes
- Sealing components that have increased requirements concerning their properties in the case of fire

Building materials

- Concrete
- Chrome
- Stainless steel
- Anodised layer
- Enamel
- Tiles
- Glass, glazed surfaces
- Ceramics
- Copper, brass
- Masonry
- Polyester
- Steel
- Zinc

Advantages

- The good fire-inhibiting properties provide maximum safety for the sealing of solid, mineral or metal building materials.
- Non-corrosive, thus can be used on aluminium, copper and zinc-plated surfaces. This guarantees problem-free use within

- the metal processing industry.
- Due to the audited, high 25% elasticity, DFS is particularly suitable for joints subjected to high stress. This guarantees a permanent seal.

12

Certificates

- EN 15651 - Part 1: F-EXT-INT-CC (25LM)
- EN 15651 - Part 2: G-CC (25LM)
- EN 15651 - Part 3: S (XS1)

Functioning

- Chemical base: 1-component silicone neutral
- Hardly flammable material (building material class DIN 4102-B1) in line with DIN 4102-1
- Permanently elastic
- Shore-A hardness 30±5
- Skin formation time: 10 to 15 minutes
- Processing temperature: +5 °C to +40 °C
- Temperature resistance: -40 °C to +150 °C
- Non-corrosive
- Very good resistance to weather, ageing and UV
- Compatible with paint
- Not paintable
- Selection table for substrates - refer to page 570

Technical data

Premium B1 silicone DFS				
Item	Item No.	Colour	Contents [ml]	Sales unit [pcs]
DFS GR (DE/EN)	053131	grey	310	12

Premium painting acrylic DMA

Quick paintable sealant with maximum security against cracks and discolourations



Wall connection joints



Internal expansion joints

Applications

- For internal and external application
- For sealing joints between wooden and metal window frames and concrete/ masonry
- Joints between walls and ceilings, steps and walls, concrete and ceiling elements and skirting
- Connection joints for shutter boxes and window sills
- Joints in dry and internal construction
- Renovation work (split jointing)

Building materials

- Concrete
- Anodised layer
- Gypsum
- Gypsum plasterboard
- Wood
- H-PVC
- Sand-lime brick
- Clinker brick
- Masonry
- Polystyrene
- Aerated concrete
- Plaster
- Brick

Advantages

- The sealant can be painted after already one hour, allowing subsequent painting work to start more quickly.
- The further-developed DMA formulation suppresses paint cracking, thus eliminating the need for time-consuming rework.
- The really good paint compatibility ensures the great adhesion of com-

- mercially available paints to the sealant and prevents the discolouration of the paint layer. This guarantees a good, even appearance.
- The water-based acrylate sealant has a neutral odour and is free from phthalate plasticisers, making it ideal for use in confined spaces.

Prüfzeugnis

- EN 15651-1:2012: Type F -EXT-INT (class 7,5P)
- GEV-EMICODE EC1 PLUS - very low emission
- French VOC-emission class A+

Functioning

- Chemical base: 1-component dispersion acrylic
- Elasto-plastic
- Low-odour
- Skin formation time: approx. 10 minutes
- Processing temperature: +5 °C to +40 °C
- Adheres on moist substrates
- Practically no shrinkage
- Temperature resistance: -20 °C to +75 °C
- Non-corrosive
- Very good resistance to weather, ageing and UV
- Compatible with paint
- Can be painted and plastered
- Free of silicone, MDI and solvents
- Selection table for substrates - refer to page 570

Technical data

Premium painting acrylic DMA				
Item	Item No.	Colour	Contents [ml]	Sales unit [pcs]
DMA W (DE/EN)	512186	pure white	310	12

Premium structured acrylic DSA

The structured acrylic sealant for plastered walls



Joints in the roof area



Closing external masonry cracks

Applications

- Filler paste to repair coarse surfaces on internal and external walls
- Connection joints with low movement
- Joints in dry and internal construction
- Joints between walls and ceilings
- Joints on window and shutter connections

Building materials

- Concrete
- Anodised layer
- Gypsum
- Gypsum plasterboard
- Wood
- H-PVC
- Sand-lime brick
- Clinker brick
- Masonry
- Polystyrene
- Aerated concrete
- Plaster
- Brick

Advantages

- The pitted structure is ideal for coarse surfaces, and ensures a perfect appearance, e.g. on rough plaster.
- The sealant can be painted and plastered and allows for an outstanding hold of standard paints/plasters on the

Certificates

- EN 15651 - Part 1: F-EXT-INT

sealant, thus guaranteeing a non-critical post-treatment.

- The good resistance to UV, weather and ageing allows for use both indoors and outdoors. This guarantees versatile and long-lasting jointing.

Functioning

- Chemical base: 1-component dispersion acrylic
- Elasto-plastic
- Low-odour
- Skin formation time: approx. 5 minutes
- Processing temperature: +5 °C to +40 °C
- Temperature resistance: -20 °C to +75 °C (rain-resistant once cured)
- Non-corrosive
- Very good resistance to weather, ageing and UV
- Compatible with paint
- Paintable
- Frost-protected in the cartridge
- Free of silicone, MDI and solvents
- Selection table for substrates - refer to page 570

Technical data

Premium structured acrylic DSA				
Item	Item No.	Colour	Contents [ml]	Sales unit [pcs]
DSA W (DE/EN)	512185	white	310	12

Acrylic sealant DA

The acrylic sealant for internal joints



Sealing door frames



Closing internal masonry cracks

Applications

- Fractures in masonry and other solid building materials in internal areas
- Connection joints with low movement
- Joints in window sill connections
- Connection joints inside buildings between windows, doors, stairs, ceilings and walls

Advantages

- The good hold on absorbent substrates guarantees a secure sealing and thus allows for a reliable and economic application.
- The sealant can be painted and plastered and allows for a good hold of standard

- paints/plasters on the sealant, thus guaranteeing a non-critical post-treatment.
- The water-based acrylate sealant has a neutral odour and is therefore ideal for use in confined spaces.

Building materials

- Concrete
- Anodised layer
- Gypsum
- Gypsum plasterboard
- Wood
- H-PVC
- Sand-lime brick
- Clinker brick
- Masonry
- Aerated concrete
- Plaster
- Brick

Certificates

- EN 15651 - Part 1: F-EXT-INT

Functioning

- Chemical base: 1-component dispersion acrylic
- Elasto-plastic
- Low-odour
- Skin formation time: approx. 20 minutes
- Processing temperature: +5 °C to +40 °C
- Temperature resistance: -20 °C to +75 °C
- Non-corrosive
- Compatible with paint
- Can be painted and plastered
- Frost-protected in the cartridge
- Free of silicone, MDI and solvents
- Selection table for substrates - refer to page 570

Technical data

Acrylic sealant DA				
Item	Item No.	Colour	Contents [ml]	Sales unit [pcs]
DA W (DE/EN)	053110	white	310	12
DA GR (DE/EN)	053111	grey	310	12
DA BR (DE/EN)	053112	brown	310	12

Repair mortar DEC

The ready-to-use, extrudable joint mortar for the long-lasting closing of masonry joints



Masonry joints



Wall breakthrough

Applications

- Repairing masonry joints
- Closing masonry cracks
- Repairing chipped edges
- Closing drill holes in facing masonry during repair work
- General repair work (e.g. drill holes with cracked edges)
- For a better reusability, to close opened cartridges with adhesive tape

Building materials

- Concrete
- Pumice
- Fibre cement
- Gypsum
- Wooden materials
- Sand-lime brick
- Ceramics
- Clinker brick
- Masonry
- Aerated concrete
- Plaster
- Cement
- Brick

Advantages

- The ready-to-use, sprayable joint mortar means that there is no need to add water or carry out time-consuming pre-mixing work. It enables clean, purposeful work. This means that you avoid dirtying surrounding areas and wasting material.
- Good adhesion even on slightly damp

- substrates practically allows for all-weather work and prevents forced interruptions.
- The structure of the high-quality water-based polymer has been perfectly designed with the visual appearance of the mortar in mind. This ensures a discreet joint and perfect appearance.

12

Functioning

- Chemical base: 1C polymer dispersion
- Plastic
- Consistency: Firm
- Practically odour-free
- Skin formation time: Approx. 10 minutes.
- Processing temperature: +5 °C to +40 °C (not below +5 °C)
- Temperature resistance up to -30 °C (fully cured)
- Weather-proof after approx. 24 hours.
- Very good resistance to UV, weather and ageing
- Paintable
- Frost-protected in the cartridge
- Free of silicone, MDI and solvents
- Not recommended for caulking guns with a transmission ratio of less than 10:1 (e.g. KPM1)
- Selection table for substrates - refer to page 570

Technical data

Repair mortar DEC					
Item	Item No.	Colour	Contents [ml]	Contents per plastic bag [pcs]	Sales unit [pcs]
DEC CG (DE/EN)	534474	cement grey	310	—	12
V-Nozzle Express Cement	524315	—	—	5	1

Premium all-weather sealant DDK

The permanently elastic joint sealant with a strong hold on all substrates



Chimney flashings



Sealing gutters

Applications

- Sealing of roofing membranes
- Grouting roof penetrations such as chimneys or light domes, as well as edge connections
- Sealing of metal and plastic gutters
- Sealings around antennas and ventilation ducts
- Sealing of chimney flashings
- Sealant for metal structures

Advantages

- Thanks to the high elasticity of 25%, DDK is ideally suited to high-stress joints. This guarantees long-lasting jointing.
- DDK holds without a base coat, including on moist and bituminous substrates, and is therefore suitable for all applications in the roofing area. For a high degree of

economy.

- The immediate rain resistance allows for external application in all weather conditions, thus avoiding interruption of work.
- DDK is non-corrosive, and thus can be used on aluminium, copper and zinc-plated surfaces. This offers maximum flexibility.

Building materials

- Concrete
- Bitumen sheeting
- Roofing felt
- Stainless steel
- Wood
- Clinker brick
- Copper
- Masonry
- Metal
- Brick
- Zinc

Functioning

- Chemical base: 1-component synthetic rubber
- Permanently elastic
- Highly transparent formulation
- Skin formation time: 15 - 20 minutes
- Processing temperature: +5 °C to +40 °C
- Temperature resistance: -25 °C to +100 °C
- Permitted overall deformation: 25%
- Allows for emergency roof repairs
- Non-corrosive
- Very good resistance to weather, ageing and UV
- Compatible with paint
- Paintable
- Frost-protected in the cartridge
- Selection table for substrates - refer to page 570

Technical data

Premium all-weather sealant DDK				
Item	Item No.	Colour	Contents [ml]	Sales unit [pcs]
DDK TR (DE/EN)	049103	transparent	310	12

Roof sealing compound DD

The special sealant to fill joints between bitumen sheeting

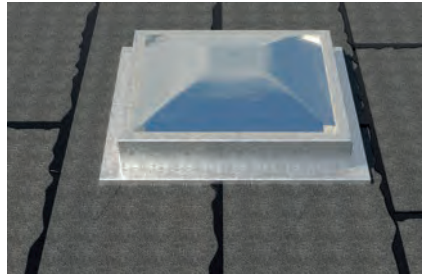

Sealings around skylights



Sealings around roofs with bitumen sheeting

Applications

- Sealing roofing membranes and roofing felt
- Bonding bitumen shingle
- Grouting roof penetrations such as chimneys or light domes, as well as edge connections
- Sealing of metal and plastic gutters
- Sealings around antennas and ventilation ducts
- Suitable for emergency repairs

Building materials

- Concrete
- Bitumen sheeting
- Roofing felt
- Stainless steel
- Wood
- Clinker brick
- Copper
- Plastics
- Masonry
- Metal
- Brick
- Zinc
- Polystyrene

Technical data

Roof sealing compound DD				
Item	Item No.	Colour	Contents [ml]	Sales unit [pcs]
DD SW (DE/EN)	053127 ¹⁾	black	310	12

1) Dangerous goods - no express shipping possible.

Advantages

- The special bitumen-based formulation seals roofing membranes and roofing felt securely. This guarantees long-lasting functionality.
- DD also holds to moist substrates without a base layer. This makes application

- largely independent of the weather and thus helps to avoid interruption of work.
- DD is non-corrosive, and thus can be used on aluminium, copper, zinc-plated surfaces and polystyrene. This offers maximum flexibility.

Functioning

- Chemical base: 1-component bitumen
- Skin formation time approx. 30 minutes
- Processing temperature: +5 °C to +45 °C
- Temperature resistance: -20 °C to +80 °C
- Hardening time: 1 to 2 mm / d
- Max. movement absorption 5%
- Non-corrosive
- Selection table for substrates - refer to page 570

KP M1



Advantages

- The handy, robust solid metal construction for standard cartridges up to 310 ml bears up against requirements on the construction site and, as such, is also suitable for professional use.
- The continuous in-feed allows for a precise dosage, making it easy to use.
- The slim shape of the device allows for an exact application, even in difficult to reach spots, thus offering a high level of flexibility

KP M3



Advantages

- The 18:1 transmission ratio makes extrusion rapid and energy-efficient even in the case of highly viscous materials, thus guaranteeing stress-free work.
- The robust design with the hardened twice drive blocks and the hardened push rod meets the tough requirements of a construction site and thus offers a long lifespan.
- The electro-welded cartridge shell is freely rotatable.
- Due to the accessible cartridge, it is possible to align the extrusion nozzle perfectly in place and guarantee application-orientated work.
- The equipment with a ladder hook facilitates the retraction of the push rod and offers a convenient possibility of depositing during work interruptions.

KP M2 Plus



Advantages

- The 18:1 transmission ratio makes extrusion rapid and energy-efficient even in the case of highly viscous materials, thus guaranteeing stress-free work.
- The robust design with the special, hardened drive block meets the tough requirements of a construction site and thus offers a long lifespan.
- Due to the accessible cartridge, it is possible to align the extrusion nozzle perfectly in place and guarantee application-orientated work.

Technical data

Accessories for sealants

Item	Item No.	Transmission ratio	Sales unit [pcs]
KP M1	053115	7:1	1
KP M3	541441	18:1	1
KP M2 Plus	053117	18:1	1

KP M600



Advantages

- The 18:1 transmission ratio makes extrusion rapid and energy-efficient even in the case of highly viscous materials, thus guaranteeing stressfree work.
- The robust design with the hardened push rod with anti-slip effect withstands the tough requirements of a construction site and thus offers a long lifespan.
- The equipment with a ladder hook facilitates the retraction of the push rod and offers a convenient possibility of depositing during work interruptions.
- Automatic tension remove (with on / off function) prevents run after.
- 2 different pusher plates (plastic for tubular bags & metal for cartridges) enable flexible use.

Technical data

Accessories for sealants			
Item	Item No.	Transmission ratio	Sales unit [pcs]
KP M600	540941	18:1	1

Zinc spray FTC-ZS

Fast-drying surface and corrosion protection with outstanding long-term effect for metals



Column bases



Metal stairs

Applications

- For all metals that need corrosion protection
- Rust protection base layer for surfaces threatened by water and weather
- For the coating of drilling and cutting points as well as welded joints
- Conductive interlayer for spot welding
- Repairing damaged zinc coatings

Building materials

- All iron and steel surfaces
- Blank laminations

Advantages

- In the salt spray test in line with DIN 50021, coated metal parts displayed no corrosion, even after 500 hours.
- The high proportion of zinc in the dry film provides secure protection to all metal surfaces that are permanently exposed to the elements.
- Thanks to the adhesive layer of corro-

sion protection and the fact that it can be painted over, it is also ideal as a high-quality base layer.

- The high resistance to cracking and flaking of a metal base material was confirmed by the mandrel flex test in line with DIN EN ISO 1519 (without damage).

Functioning

- Dark-grey colour (similar to RAL 7042)
- Metal proportion of over 92% in dry film
- Shake can well for approx. 3 minutes
- Apply at a distance of 20–30 cm in a cross coat
- Surface dust-dry after just approx. 8 minutes
- Fully hardened within 24 hours
- Smooth, non-porous film
- Abrasion-resistant
- Excellent corrosion protection with long-term effect
- Heat-resistant up to approx. 500 °C
- Electroconductive and suitable for spot welding
- Ideal processing temperature of 16 °C to 25 °C

Technical data

Zinc spray FTC-ZS			
Item	Item No.	Contents [ml]	Sales unit [pcs]
FTC-ZS (EN/FR/ES/PT)	509242 ¹⁾	400	12

¹⁾ Dangerous goods - no express shipping possible.

Zinc-alu spray FTC-ZA

Ideal for repairing damaged zinc coatings using colour-matching corrosion protection.

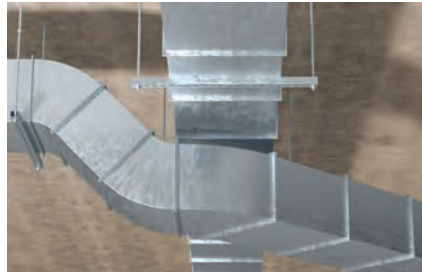

Ventilation systems



Ladders

Applications

- For post-galvanising and repairing damaged areas of galvanised parts, drilling and cutting points and welded joints
- Repairing damaged zinc coatings
- Climate control and ventilation technology
- Guard rails
- Metal constructions
- Sheet metal coverings

Building materials

- All iron and steel surfaces
- Hot-dip galvanised surfaces following drilling, ironwork or welding
- Non-ferrous heavy metal

Advantages

- Zinc-alu spray represents a subtle repair to damaged hot-dip galvanised areas thanks to its colour matching with the hot-dip galvanisation.
- Thanks to the excellent holding properties on blank metal, it guarantees a

- lasting connection to the base material.
- The fast-drying Zinc-alu spray guarantees good, weatherproof corrosion protection and, as such, is suitable for use both indoors and out.

12

Functioning

- Silver-grey colour (similar to RAL 9006) with high gloss level
- Shake can well for approx. 2 minutes
- Apply at a distance of 25–30 cm in a cross coat
- Surface dust-dry after just approx. 8 minutes
- Touch-dry after 20–25 minutes
- Fully hardened within 24 hours
- Smooth, non-porous film
- High abrasion resistance
- Long-term heat resistance up to approx. 200 °C (briefly up to 300 °C)
- Ideal processing temperature of 16 °C to 25 °C

Technical data

Zinc-alu spray FTC-ZA			
Item	Item No.	Contents [ml]	Sales unit [pcs]
FTC-ZA (EN/FR/ES/PT)	509241 ¹⁾	400	12





¹⁾ Dangerous goods - no express shipping possible.



13

13

Adhesives

Assembly adhesive MK	596	
Power adhesive express KK	597	
Multi Adhesive & Sealant KD	598	
Multi Adhesive & Sealant CRYSTAL KDC	600	
High Tack Flex-Adhesive HTM	601	

Assembly adhesive MK

The building adhesive for interior areas with high initial adhesion



Skirting



Timber constructions

Applications

- Skirting
- Timber sub-structures
- Décorative, acoustic and insulation panels
- Cable ducts
- Window sills
- Tiles
- Door signs

Building materials

- Concrete
- Pumice
- Fibre cement
- Gypsum
- Gypsum plasterboard
- Wood
- H-PVC
- Sand-lime brick
- Clinker brick
- Masonry
- Metal
- Polystyrene hard foam
- Aerated concrete
- Plaster
- Brick

Advantages

- The extremely high initial adhesion of 200 kg/m² makes it possible to attach lots of components without the need for additional fixings, and thus reduces the amount of time required.
- The components can be adjusted for a few minutes after they have been attached. This makes installation easier.

- The acrylate adhesive has a neutral odour and is therefore ideal for use in confined spaces.
- The special recipe makes it compatible with foamed polystyrene, e.g. Styro-foam®. MK is, therefore, suitable for a broad range of applications.

Certificates

- EMICODE® EC 1 Plus - very low emission
- French VOC-emission class A+

Function / assembly

- Chemical base: One-component acrylate dispersion
- Creme white in colour
- Processing temperature +10 °C to +30 °C
- Setting time approx. 15 minutes
- Very high initial adhesion of 200 kg/m²
- Fully functional after 24 to 48 hours
- High ultimate strength (up to 22 kg/cm² for wood to wood)
- Temperature resistance -20 °C to +60 °C
- Non-drip (suitable for use on ceilings)
- Addresses uneven surfaces
- At least one of the components to be bonded must be absorbent.
- Reclosable nozzle
- Free from solvents, silicone and MDI
- Extrude with silicone application gun

Technical data

Assembly adhesive MK						
Item	Item No.	Contents [ml]	Contents [g]	Type of packaging	Colour	Sales unit [pcs]
MK WHITE 310ML (DE/EN)	053128	310	400	Cartridge	white	12

Power adhesive express KK

The building adhesive for extremely fast and water-resistant bond with a high final strength



Capstones

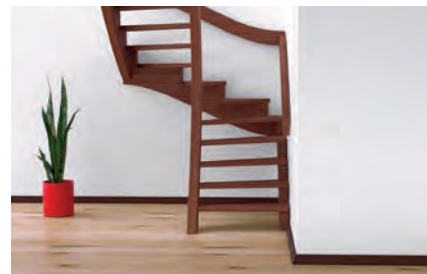

Bonding in interior construction

Applications

- Gluing timber sub-structures
- Stair construction and stair renovations
- Laminate cladding
- Skirting boards
- Décorative, acoustic and insulation panels
- Professional modelling
- Door signs
- Cable ducts
- General repair and installation mortar

Building materials

- ABS
- Concrete
- Pumice
- Anodised layer
- Fibre cement
- Gypsum
- Gypsum plasterboard
- Wooden materials
- H-PVC
- Sand-lime brick
- Ceramics
- Clinker brick
- Masonry
- Metal
- Natural stone
- Polystyrene hard foam
- Aerated concrete
- Plaster
- Brick

Technical data

Power adhesive express KK						
Item	Item No.	Contents [ml]	Contents [g]	Type of packaging	Colour	Sales unit [pcs]
KK BEIGE 310ML (DE/EN)	059014	310	460	Cartridge	beige	12

Advantages

- The polyurethane adhesive is resistant to moisture and thus can be used in exterior areas.
- The extremely quick hardening shortens the pressing and joining times. Thus subsequent work can be completed more quickly.

Certificates

- According to the requirements of DIN EN 204-D4 to weathering resistant bondings of wood and derived wood products
- According to the requirements of DIN EN 14257 (Watt 91) to temperature-resistant bondings of wood and derived wood products
- Conform to LEED® IEQ-credits 4.1 (Indoor Environmental Quality) adhesives and sealants
- EMICODE® EC 1 Plus - very low emission

- The optimised recipe achieves a high adhesion, including in the case of high temperatures, for high security.
- The special recipe makes it compatible with foamed polystyrene, e.g. Styro-foam®. Thus, KK is suitable for a broad range of applications.

Function / assembly

- Chemical base: One-component PUR adhesive
- Beige in colour
- Processing temperature 0 °C to +35 °C
- Setting time approx. 3 minutes
- Fully functional after approx. 10 minutes (for invisible joints)
- High final strength of > 10 N/mm² (> 100 kg/cm²)
- Temperature resistance -40 °C to +110 °C
- Non-drip (suitable for use on ceilings)
- Lightly foaming / bridges gaps
- Assembly parts have to be fixed until functional strength has been reached
- Reclosable nozzle
- Free from solvents and silicone
- Extrude with silicone application gun

Multi Adhesive & Sealant KD

The flexible sealant & adhesive for indoors and outdoors with adhesive strength even on wet surfaces



Sheet metal coverings

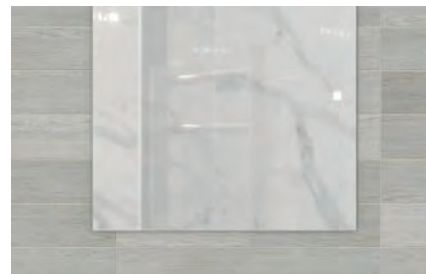

Bonding and sealing of mirrors

Applications

Stress-compensating bonding and sealing of:

- For airtight sealing applications
- Standard mirrors
- Vibrating constructions
- Metal profiles
- Suitable for use in HVAC systems according to VDI 6022, Sheet 1
- Joints and seams in ventilated constructions
- Insulation material, ledges, panels and cladding
- Kitchens and built-in furniture
- Stair treads and window sills
- Floor joints, connection joints in car body, vehicle construction, metal construction and ship building

Advantages

- The extremely high initial adhesion of 185 kg/m² makes it possible to attach lots of components without the need for additional fixing, and thus reduces the amount of time required.
- The MS polymer® allows for an elastic adhesion for vibration-dampening and stress-compensating connections for demanding applications.
- KD is almost odour-free and therefore particularly suitable for closed rooms.
- Non-corrosive, thus can be used on copper and zinc plated surfaces for maximum flexibility in application.

Building materials

- ABS
- Concrete
- Pumice
- Gypsum plasterboard
- Glass
- Wooden materials
- H-PVC
- Ceramics
- Copper
- Masonry, clinker brick
- Metals
- Polycarbonate and PMMA
- Polystyrene hard foam
- Aerated concrete
- Plaster
- Brick

Characteristics

- EN 15651 - Part 1: F EXT-INT-CC (25HM)
- EN 15651 - Part 3: S (XS3)
- EN 15651 - Part 4: PW-EXT-INT-CC (25HM)
- DIN EN ISO 846 (Tested resistance to mould and bacteria)
- EMICODE® EC 1 Plus - very low emission
- French VOC-emission class A+
- ISEGA (Declaration of no objection: Tested for short-term contact with food)
- M1 (Emission class for building materials)

Function / assembly

- Chemical base: One-component hybrid polymer
- Processing temperature +5 °C to +40 °C
- Setting time approx. 5 minutes
- High initial adhesion of 185 kg/m²
- Curing: approx. 3 mm per day
- High elasticity of 25 %
- Shore A 52
- Temperature resistance: -40 °C to +90 °C
- Also bonds on a moist base material
- Prevents mould build-up, even without additional ingredients
- Suitable for bonding non-absorbent components (see TDS)
- Can be painted (see TDS)
- Free from solvents and silicone
- Waterproof and Sea water resistant
- Very good resistance to weather, age and UV

Technical data

Multi Adhesive & Sealant KD						
Item	Item No.	Contents [ml]	Contents [g]	Type of packaging	Colour	Sales unit [pcs]
KD BLACK 290ML (DE/EN)	503319	290	420	Cartridge	black	12
KD GREY 290ML (DE/EN)	503318	290	420	Cartridge	grey	12
KD white 290ML (DE/EN)	059389	290	420	Cartridge	white	12

Multi Adhesive & Sealant CRYSTAL KDC

The crystal clear multi adhesive for discreet adhesive and sealant joints for interior and exterior use.



Bonding and sealing aluminium profiles



For invisible glued and sealed joints

Applications

Stress-compensating bonding and sealing of:

- Glass and other transparent materials, preferably in interior areas
- Insulation material, ledges, panels and cladding
- Kitchens and built-in furniture
- Constructions in timber, bodywork, metal, container and shipbuilding industries

Advantages

- The crystal clear formula is perfect for discreet adhesion and sealing and guarantees the optimum appearance.
- The high initial adhesion of 175 kg/m² allows many components to be attached without additional fixing.
- Thanks to the high elasticity, KDC crystal clear is also ideally suited for high-stress expansion joints and guarantees perma-

- nent sealing at all times.
- Non-corrosive and non bleeding, thus can be used on copper and zinc plated surfaces as well as natural stone for maximum flexibility in application.
- KDC crystal clear is almost odour-free and therefore particularly suitable for closed rooms.

Building materials

- ABS
- Concrete
- Stainless steel
- Anodised layer
- Tiles
- Glass, glazed surfaces
- Wooden materials
- H-PVC
- Ceramics
- Copper, brass
- Masonry, clinker brick
- Metals
- Natural stone
- Polycarbonate and PMMA
- Polystyrene hard foam
- Steel
- Brick
- Zinc

Certificates

- EN 15651 - Part 1: F-EXT-INT (12,5P)
- EN 15651 - Part 3: S (S1)
- EMICODE® EC 1 Plus - very low emission
- French VOC-emission class A+

Functioning

- Chemical Base: One-component hybrid polymer
- Very easy to apply
- Prevents the formation of mould, even without additional active substances
- Skin formation time: approx. 10 minutes
- High initial adhesion of 175 kg/m²
- Fast curing rate up to 4,5 mm/24h
- Processing temperature: +5 °C to +40 °C
- High elasticity of 20%
- Shore A 40 ± 5
- Also bonds on a moist base material
- Temperature resistance: -40 °C to +110 °C
- Compatible with paint; paintable
- Free from solvents, isocyanat, silicone and phthalate

Technical data

Multi Adhesive & Sealant CRYSTAL KDC						
Item	Item No.	Contents [ml]	Contents [g]	Type of packaging	Colour	Sales unit [pcs]
KDC CRYSTAL 290ML (DE/EN)	503317	290	300	Cartridge	crystal clear	12

High Tack Flex-Adhesive HTM

Flexible high-performance adhesive with very high initial adhesion even on natural stone



Bonding of wall cladding



Bonding of mirrors

Applications

Stress compensating bonding of:

- Standard mirrors
- Vibrating constructions
- Metal profiles
- Seams in ventilation construction
- Insulation material, ledges, panels and cladding
- Kitchens and built-in furniture
- Stair treads and window sills
- Different types of stone
- Also of non-absorbent materials (see technical data sheet)
- A wide variety of materials in container, body, metal, ship and vehicle construction

Building materials

- ABS
- Concrete
- Stainless steel
- Anodised layer
- Natural stone, marble, granite
- Glass, glazed surfaces
- Wooden materials
- H-PVC
- Ceramics
- Copper, brass
- Masonry, clinker brick, tiles
- Metals
- Polycarbonate and PMMA
- Polystyrene hard foam
- HPL panels
- Brick
- Zinc

Advantages

- The extremely high initial adhesion makes it possible to attach lots of components without the need for additional fixings, and thus reduces the amount of time required.
- The high final tensile strength of 2.2 N/mm² guarantees really safe glued connections.

- The MS Polymer® enables elastic bonding for vibration-dampening and stress-compensating connections in challenging applications.
- HTM is practically odourless and is therefore ideal for use in confined spaces.
- It is non-corrosive and can therefore be used on aluminium, copper and zinc-plated surfaces, making it particularly flexible.

13

Test certificate

- EMICODE EC 1 Plus - very low emission
- French VOC emission class A+

Functionality

- Chemical base: One-component hybrid polymer
- Colour: White
- Processing temperature +5 °C to +40 °C
- Processing time of around 10 minutes
- Hardening time of 2-3 mm/24 h
- Extremely high initial adhesion > 290 kg/m²
- Shore A 56
- Temperature resistance: -40 °C to +90 °C
- Adhesive, even on a damp base
- Suitable for bonding non-absorbent components (see TDS)
- Can be painted (see TDS)
- Free from solvents, MDI and silicone
- Very good resistance to weather, ageing and UV

Technical data











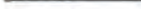

High Tack Flex-Adhesive HTM

Item	Item No.	Contents [ml]	Contents [g]	Type of packaging	Colour	Sales unit [pcs]
HTM WH 290 (DE/EN)	541712	290	450	Cartridge	white	12
V-Nozzle Express Cement	524315	–	–	–	–	1

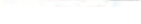

14

Drills and bits

Hammer drill bit Quattric II	606	
Hammer drill bit SDS Plus II Pointer	610	
Masonry drill bit Pointer M	614	
Hammer drill bit SDS Max II / SDS Max IV	615	
Hollow drill bit FHD	618	
Stone drill bit D-S	620	
Premium chisel FCP	621	
Standard chisel	622	
ProfiBit FPB	623	
DiamondBit FDB	624	
MaxxBit FMB	625	
BitHolder FBH	626	
BitSet	627	
Accessories for impact driver	628	

Hammer drill bit Quattric II

The expert for the best performance in reinforced concrete



Applications

To create approval-compliant drill holes in:

- Reinforced concrete
- Concrete
- Solid brick
- Sand-lime brick

Also suitable for:

- Natural stone

Advantages

- Carbide head (up to \varnothing 10 mm) for long service life.
- Power shoulders for improved breakup performance in concrete.
- Massive main cutting edges for quick drilling progress.
- Reinforcement chamfers prevent jamming in the reinforcement.
- Centring tip for simple positioning.
- Wear mark for simple recognition of wear limit in accordance with PGM.
- Two-piece spiral for quick drilling progress and increased service life.

14

Characteristics



Technical data

Hammer drill bit Quattric II

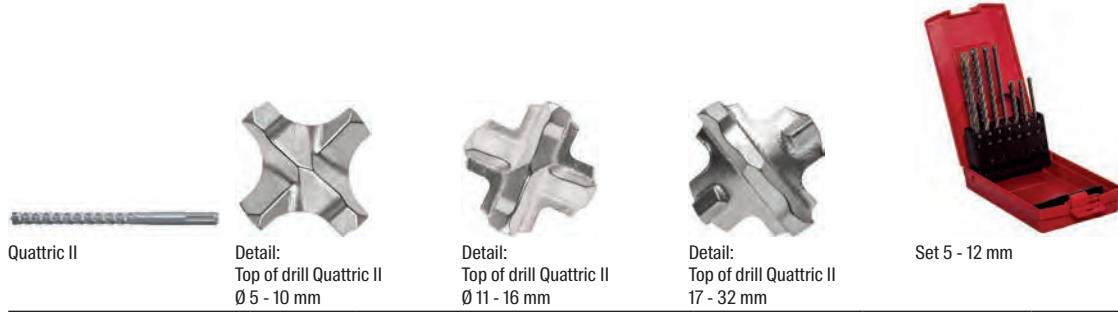

Item	Item No.	Drill hole diameter d_0 [mm]	Working length [mm]	Total length l [mm]	Type of packaging	Contents	Sales unit [pcs]
Quattric II 5/50/115	549973	5	50	115	Plastic clip	1	1
Quattric II 5/100/165	549974	5	100	165	Plastic clip	1	1
Quattric II 5/150/215	544214	5	150	215	Plastic clip	1	1
Quattric II 5,5/50/115	549971	5,5	50	115	Plastic clip	1	1
Quattric II 5,5/100/165	549972	5,5	100	165	Plastic clip	1	1
Quattric II 6/50/115	549983	6	50	115	Plastic clip	1	1
Quattric II 6/100/165	549979	6	100	165	Plastic clip	1	1
Quattric II 6/150/215	549981	6	150	215	Plastic clip	1	1
Quattric II 6/200/265	549985	6	200	265	Plastic clip	1	1
Quattric II 6/250/315	549986	6	250	315	Plastic clip	1	1
Quattric II 6,5/100/165	549975	6,5	100	165	Plastic clip	1	1
Quattric II 6,5/150/215	549976	6,5	150	215	Plastic clip	1	1
Quattric II 6,5/200/265	549977	6,5	200	265	Plastic clip	1	1
Quattric II 6,5/250/315	549978	6,5	250	315	Plastic clip	1	1
Quattric II 8/50/115	549993	8	50	115	Plastic clip	1	1
Quattric II 8/100/165	549988	8	100	165	Plastic clip	1	1
Quattric II 8/150/215	549990	8	150	215	Plastic clip	1	1
Quattric II 8/200/265	549994	8	200	265	Plastic clip	1	1
Quattric II 8/250/315	549992	8	250	315	Plastic clip	1	1
Quattric II 8/300/365	549995	8	300	365	Plastic clip	1	1
Quattric II 8/400/465	549996	8	400	465	Plastic clip	1	1
Quattric II 10/50/115	549928	10	50	115	Plastic clip	1	1
Quattric II 10/100/165	549922	10	100	165	Plastic clip	1	1
Quattric II 10/150/215	549925	10	150	215	Plastic clip	1	1
Quattric II 10/200/265	549929	10	200	265	Plastic clip	1	1
Quattric II 10/250/315	549927	10	250	315	Plastic clip	1	1
Quattric II 10/300/365	544224	10	300	365	Plastic clip	1	1
Quattric II 10/390/455	549930	10	390	455	Plastic clip	1	1
Quattric II 10/540/600	544222	10	540	600	Plastic clip	1	1
Quattric II 12/110/160	549932	12	110	160	Plastic clip	1	1
Quattric II 12/160/210	549936	12	160	210	Plastic clip	1	1
Quattric II 12/210/260	549934	12	210	260	Plastic clip	1	1
Quattric II 12/260/310	549939	12	260	310	Plastic clip	1	1
Quattric II 12/400/450	549935	12	400	450	Plastic clip	1	1
Quattric II 12/550/600	544213	12	550	600	Plastic clip	1	1
Quattric II 12/950/1000	549931	12	950	1000	Plastic clip	1	1
Quattric II 14/110/160	549941	14	110	160	Plastic clip	1	1
Quattric II 14/160/210	549944	14	160	210	Plastic clip	1	1
Quattric II 14/210/260	549942	14	210	260	Plastic clip	1	1
Quattric II 14/260/310	549945	14	260	310	Plastic clip	1	1
Quattric II 14/400/450	549943	14	400	450	Plastic clip	1	1
Quattric II 14/550/600	544223	14	550	600	Plastic clip	1	1
Quattric II 14/950/1000	549940	14	950	1000	Plastic clip	1	1
Quattric II 15/110/160	549946	15	110	160	Plastic clip	1	1
Quattric II 15/160/210	549947	15	160	210	Plastic clip	1	1
Quattric II 15/210/260	544215	15	210	260	Plastic clip	1	1

Technical data

Hammer drill bit Quattric II

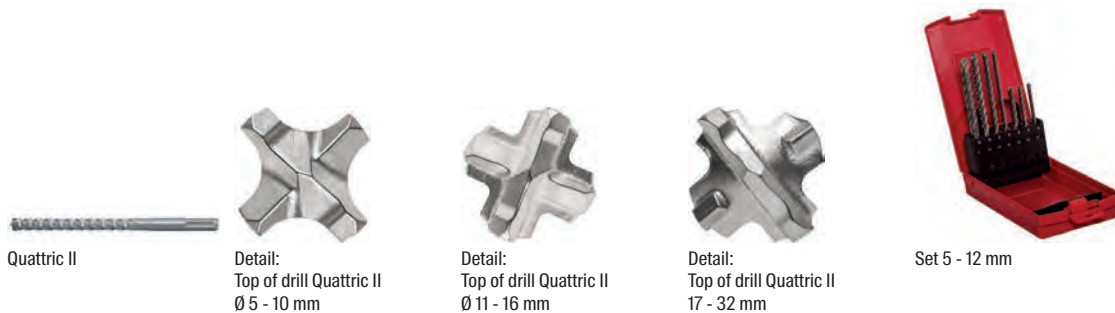

Item	Item No.	Drill hole diameter d ₀ [mm]	Working length [mm]	Total length l [mm]	Type of packaging	Contents	Sales unit [pcs]
Quattric II 16/110/160	549950	16	110	160	Plastic clip	1	1
Quattric II 16/160/210	549951	16	160	210	Plastic clip	1	1
Quattric II 16/210/260	549952	16	210	260	Plastic clip	1	1
Quattric II 16/260/310	549953	16	260	310	Plastic clip	1	1
Quattric II 16/400/450	549954	16	400	450	Plastic clip	1	1
Quattric II 16/550/600	549955	16	550	600	Plastic clip	1	1
Quattric II 16/950/1000	549948	16	950	1000	Plastic clip	1	1
Quattric II 18/200/250	549956	18	200	250	Plastic tube	1	1
Quattric II 18/400/450	549957	18	400	450	Plastic tube	1	1
Quattric II 20/200/250	549958	20	200	250	Plastic tube	1	1
Quattric II 20/400/450	549959	20	400	450	Plastic tube	1	1
Quattric II 22/200/250	549960	22	200	250	Plastic tube	1	1
Quattric II 22/400/450	549961	22	400	450	Plastic tube	1	1
Quattric II 24/200/250	549962	24	200	250	Plastic tube	1	1
Quattric II 24/400/450	549963	24	400	450	Plastic tube	1	1
Quattric II 25/200/250	549964	25	200	250	Plastic tube	1	1
Quattric II 25/400/450	549965	25	400	450	Plastic tube	1	1
Quattric II 28/200/250	549966	28	200	250	Plastic tube	1	1
Quattric II 28/400/450	549967	28	400	450	Plastic tube	1	1
Quattric II 30/200/250	549968	30	200	250	Plastic tube	1	1
Quattric II 30/400/450	549969	30	400	450	Plastic tube	1	1
Quattric II 32/400/450	549970	32	400	450	Plastic tube	1	1
Quattric II 6/50/115 XP5	549984	6	50	115	Plastic tube	5	1
Quattric II 6/100/165 XP5	544225	6	100	165	Plastic tube	5	1
Quattric II 6/150/215 XP5	549982	6	150	215	Plastic tube	5	1
Quattric II 6/200/265 XP5	552131	6	200	265	Plastic tube	5	1
Quattric II 6,5/100/165 XP5	544217	6,5	100	165	Plastic tube	5	1
Quattric II 6,5/150/215 XP5	544218	6,5	150	215	Plastic tube	5	1
Quattric II 6,5/200/265 XP5	544219	6,5	200	265	Plastic tube	5	1
Quattric II 8/100/165 XP5	549989	8	100	165	Plastic tube	5	1
Quattric II 8/150/215 XP5	549991	8	150	215	Plastic tube	5	1
Quattric II 8/200/265 XP5	552132	8	200	265	Plastic tube	5	1
Quattric II 10/100/165 XP5	549924	10	100	165	Plastic tube	5	1
Quattric II 10/150/215 XP5	549926	10	150	215	Plastic tube	5	1
Quattric II 10/200/265 XP5	552133	10	200	265	Plastic tube	5	1
Quattric II 12/110/160 XP5	549933	12	110	160	Plastic tube	5	1
Quattric II 12/160/210 XP5	549937	12	160	210	Plastic tube	5	1
Quattric II 12/210/260 XP5	549938	12	210	260	Plastic tube	5	1
Quattric II 12/260/310 XP5	552134	12	260	310	Plastic tube	5	1
Quattric II 14/110/160 XP5	544220	14	110	160	Plastic tube	5	1
Quattric II 14/160/210 XP5	544221	14	160	210	Plastic tube	5	1
Quattric II 6/100/165 XP10	549980	6	100	165	Plastic tube	10	1
Quattric II 6/150/215 XP10	544185	6	150	215	Plastic tube	10	1
Quattric II 8/100/165 XP10	544216	8	100	165	Plastic tube	10	1
Quattric II 8/150/215 XP10	544186	8	150	215	Plastic tube	10	1
Quattric II 10/100/165 XP10	549923	10	100	165	Plastic tube	10	1

Technical data

Hammer drill bit Quattric II

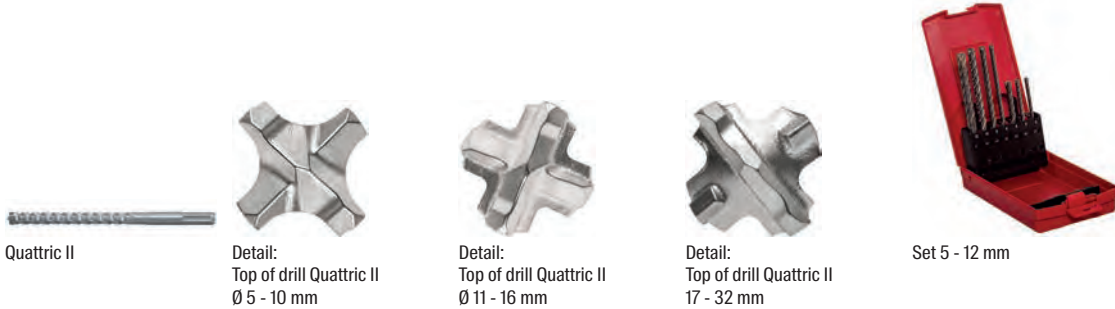

Item	Item No.	Drill hole diameter d ₀ [mm]	Working length [mm]	Total length l [mm]	Type of packaging	Contents	Sales unit [pcs]
Quattric II 10/150/215 XP10	544187	10	150	215	Plastic tube	10	1
Quattric II 12/110/160 XP10	552129	12	110	160	Plastic tube	10	1
Quattric II 12/160/210 XP10	544188	12	160	210	Plastic tube	10	1
Quattric II 12/210/260 XP10	552130	12	210	260	Plastic tube	10	1
Quattric II Set 5 - 12 mm	553210	5	50	115	Cassette	7	1
		6	50	115			
		6	100	165			
		8	50	115			
		8	100	165			
		12	100	165			
		12	110	160			

Hammer drill bit SDS Plus II Pointer

The two-flute cutter is setting new standards when it comes to drilling speed



Applications

To create approval-compliant drill holes in:

- Concrete
- Solid brick
- Sand-lime brick

Also suitable for:

- Natural stone

Advantages

- The optimised drill bit geometry enables fast drilling progress, reduced wear and less effort.
- The centring tip allows easy and precise drilling and prevents slipping on smooth surfaces.
- The “Power Breakers” on the drill bit head have a “destructive effect”. They create micro-cracks in the material and achieve a noticeably improved drilling speed.
- The larger reinforcement chamfers (+35%) guarantee that the drill acts in the best possible way when it hits concrete

reinforcements. This considerably reduces the risk of problems caused by drill jamming.

- The new Vario KVS spiral offers further advantages: The narrow crown width behind the drill bit head reduces friction and ensures stronger energy transfer during percussion drilling. The improved helix enables ideal transport of the drill residues. The spiral shape increases the stability and thus also the break resistance.

Characteristics



Technical data

Hammer drill bit SDS Plus II Pointer



SDS Plus II Pointer



Detail: top of drill SDS Plus II Pointer

Item	Item No.	Drill hole diameter d_0 [mm]	Working length [mm]	Total length l [mm]	Type of packaging	Contents [pcs]	Sales unit [pcs]
SDS Plus-V II 4/50/110	531753	4	50	110	Plastic clip	1	1
SDS Plus-V II 4/100/160	531754	4	100	160	Plastic clip	1	1
SDS Plus-V II 5/50/110	531755	5	50	110	Plastic clip	1	1
SDS Plus-V II 5/100/160	531756	5	100	160	Plastic clip	1	1
SDS Plus-V II 5/150/210	531757	5	150	210	Plastic clip	1	1
SDS Plus-V II 5/250/310	531759	5	250	310	Plastic clip	1	1
SDS Plus-V II 5,5/100/160	531761	5,5	100	160	Plastic clip	1	1
SDS Plus-V II 5,5/150/210	531762	5,5	150	210	Plastic clip	1	1
SDS Plus-V II 5,5/250/310	531763	5,5	250	310	Plastic clip	1	1
SDS Plus-V II 6/50/110	531765	6	50	110	Plastic clip	1	1
SDS Plus-V II 6/100/160	531766	6	100	160	Plastic clip	1	1
SDS Plus-V II 6/150/210	531767	6	150	210	Plastic clip	1	1
SDS Plus-V II 6/200/260	531768	6	200	260	Plastic clip	1	1
SDS Plus-V II 6/250/310	531769	6	250	310	Plastic clip	1	1
SDS Plus-V II 6,5/50/110	531770	6,5	50	110	Plastic clip	1	1
SDS Plus-V II 6,5/100/160	531771	6,5	100	160	Plastic clip	1	1
SDS Plus-V II 6,5/150/210	531772	6,5	150	210	Plastic clip	1	1
SDS Plus-V II 6,5/200/260	531773	6,5	200	260	Plastic clip	1	1
SDS Plus-V II 6,5/250/310	531774	6,5	250	310	Plastic clip	1	1
SDS Plus-V II 7/50/110	531775	7	50	110	Plastic clip	1	1
SDS Plus-V II 7/100/160	531776	7	100	160	Plastic clip	1	1
SDS Plus-V II 7/150/210	531777	7	150	210	Plastic clip	1	1
SDS Plus-V II 7/190/250	531778	7	190	250	Plastic clip	1	1
SDS Plus-V II 8/50/110	531779	8	50	110	Plastic clip	1	1
SDS Plus-V II 8/100/160	531780	8	100	160	Plastic clip	1	1
SDS Plus-V II 8/150/210	531781	8	150	210	Plastic clip	1	1
SDS Plus-V II 8/200/260	531782	8	200	260	Plastic clip	1	1
SDS Plus-V II 8/250/310	531783	8	250	310	Plastic clip	1	1
SDS Plus-V II 8/340/400	531784	8	340	400	Plastic clip	1	1
SDS Plus-V II 8/400/460	531785	8	400	460	Plastic clip	1	1
SDS Plus-V II 8/540/600	531786	8	540	600	Plastic clip	1	1
SDS Plus-V II 9/100/160	531788	9	100	160	Plastic clip	1	1
SDS Plus-V II 9/150/210	531789	9	150	210	Plastic clip	1	1
SDS Plus-V II 9,5/100/160	531790	9,5	100	160	Plastic clip	1	1
SDS Plus-V II 10/50/110	531791	10	50	110	Plastic clip	1	1
SDS Plus-V II 10/100/160	531792	10	100	160	Plastic clip	1	1
SDS Plus-V II 10/150/210	531793	10	150	210	Plastic clip	1	1
SDS Plus-V II 10/200/260	531794	10	200	260	Plastic clip	1	1
SDS Plus-V II 10/250/310	531795	10	250	310	Plastic clip	1	1
SDS Plus-V II 10/290/350	531796	10	290	350	Plastic clip	1	1
SDS Plus-V II 10/390/450	531797	10	390	450	Plastic clip	1	1
SDS Plus-V II 10/550/600	531798	10	540	600	Plastic clip	1	1
SDS Plus-V II 10/740/800	531799	10	740	800	Plastic clip	1	1
SDS Plus-V II 10/950/1000	531800	10	940	1000	Plastic clip	1	1
SDS Plus-V II 11/110/160	531801	11	100	160	Plastic clip	1	1
SDS Plus-V II 11/260/310	531802	11	260	310	Plastic clip	1	1
SDS Plus-V II 12/110/160	531803	12	110	160	Plastic clip	1	1
SDS Plus-V II 12/160/210	531804	12	160	210	Plastic clip	1	1
SDS Plus-V II 12/210/260	531805	12	210	260	Plastic clip	1	1
SDS Plus-V II 12/260/310	531806	12	260	310	Plastic clip	1	1

Technical data

Hammer drill bit SDS Plus II Pointer



SDS Plus II Pointer



Detail: top of drill SDS Plus II Pointer

Item	Item No.	Drill hole diameter d_0 [mm]	Working length [mm]	Total length l [mm]	Type of packaging	Contents [pcs]	Sales unit [pcs]
SDS Plus-V II 12/310/360	531807	12	310	360	Plastic clip	1	1
SDS Plus-V II 12/400/450	531808	12	400	450	Plastic clip	1	1
SDS Plus-V II 12/550/600	531809	12	550	600	Plastic clip	1	1
SDS Plus-V II 12/950/1000	531810	12	950	1000	Plastic clip	1	1
SDS Plus-V II 13/110/160	531811	13	100	160	Plastic clip	1	1
SDS Plus-V II 13/160/210	531812	13	160	210	Plastic clip	1	1
SDS Plus-V II 13/210/260	531813	13	210	260	Plastic clip	1	1
SDS Plus-V II 13/260/310	531814	13	260	310	Plastic clip	1	1
SDS Plus-V II 14/110/160	531815	14	110	160	Plastic clip	1	1
SDS Plus-V II 14/160/210	531816	14	160	210	Plastic clip	1	1
SDS Plus-V II 14/210/260	531817	14	210	260	Plastic clip	1	1
SDS Plus-V II 14/260/310	531818	14	260	310	Plastic clip	1	1
SDS Plus-V II 14/400/450	531819	14	400	450	Plastic clip	1	1
SDS Plus-V II 14/550/600	531820	14	550	600	Plastic clip	1	1
SDS Plus-V II 14/950/1000	531821	14	950	1000	Plastic clip	1	1
SDS Plus-V II 15/110/160	531822	15	110	160	Plastic clip	1	1
SDS Plus-V II 15/160/210	531823	15	160	210	Plastic clip	1	1
SDS Plus-V II 15/210/260	531824	15	210	260	Plastic clip	1	1
SDS Plus-V II 15/400/450	531825	15	400	450	Plastic clip	1	1
SDS Plus-V II 16/110/160	531826	16	110	160	Plastic clip	1	1
SDS Plus-V II 16/160/210	531827	16	160	210	Plastic clip	1	1
SDS Plus-V II 16/210/260	531828	16	210	260	Plastic clip	1	1
SDS Plus-V II 16/260/310	531829	16	260	310	Plastic clip	1	1
SDS Plus-V II 16/400/450	531830	16	400	450	Plastic clip	1	1
SDS Plus-V II 16/550/600	531831	16	550	600	Plastic clip	1	1
SDS Plus-V II 16/750/800	531832	16	750	800	Plastic clip	1	1
SDS Plus-V II 16/950/1000	531833	16	950	1000	Plastic clip	1	1
SDS Plus-V II 17/160/210	531834	17	160	210	Plastic clip	1	1
SDS Plus-V II 17/400/450	531835	17	400	450	Plastic clip	1	1
SDS Plus-V II 18/150/200	531836	18	150	200	Plastic clip	1	1
SDS Plus-V II 18/250/300	531837	18	250	300	Plastic clip	1	1
SDS Plus-V II 18/400/450	531838	18	400	450	Plastic clip	1	1
SDS Plus-V II 18/550/600	531839	18	550	600	Plastic clip	1	1
SDS Plus-V II 18/950/1000	531840	18	950	1000	Plastic clip	1	1
SDS Plus-V II 19/150/200	531841	19	150	200	Plastic clip	1	1
SDS Plus-V II 19/400/450	531842	19	400	450	Plastic clip	1	1
SDS Plus-V II 20/150/200	531843	20	150	200	Plastic clip	1	1
SDS Plus-V II 20/250/300	531844	20	250	300	Plastic clip	1	1
SDS Plus-V II 20/400/450	531845	20	400	450	Plastic clip	1	1
SDS Plus-V II 20/550/600	531846	20	550	600	Plastic clip	1	1
SDS Plus-V II 20/950/1000	531847	20	950	1000	Plastic clip	1	1
SDS Plus-V II 22/200/250	531849	22	200	250	Plastic clip	1	1
SDS Plus-V II 22/400/450	531850	22	400	450	Plastic clip	1	1
SDS Plus-V II 22/550/600	531851	22	550	600	Plastic clip	1	1
SDS Plus-V II 22/950/1000	531852	22	950	1000	Plastic clip	1	1
SDS Plus-V II 24/200/250	531853	24	200	250	Plastic clip	1	1
SDS Plus-V II 24/400/450	531854	24	400	450	Plastic clip	1	1
SDS Plus-V II 25/200/250	531855	25	200	250	Plastic clip	1	1
SDS Plus-V II 25/400/450	531856	25	400	450	Plastic clip	1	1
SDS Plus-V II 25/550/600	531857	25	550	600	Plastic clip	1	1

Technical data

Hammer drill bit SDS Plus II Pointer



SDS Plus II Pointer



Detail: top of drill SDS Plus II Pointer

Item	Item No.	Drill hole diameter d_0 [mm]	Working length [mm]	Total length l [mm]	Type of packaging	Contents [pcs]	Sales unit [pcs]
SDS Plus-V II 26/200/250	531858	26	200	250	Plastic clip	1	1
SDS Plus-V II 26/400/450	531859	26	400	450	Plastic clip	1	1
SDS Plus-V II 6/50/110 XP10	531860	6	50	110	Plastic tube	10	1
SDS Plus-V II 6/100/160 XP10	531861	6	100	160	Plastic tube	10	1
SDS Plus-V II 8/100/160 XP10	531862	8	100	160	Plastic tube	10	1
SDS Plus-V II 8/150/210 XP10	531863	8	150	210	Plastic tube	10	1
SDS Plus-V II 10/100/160 XP10	531864	10	100	160	Plastic tube	10	1
SDS Plus-V II 10/150/210 XP10	531865	10	150	210	Plastic tube	10	1
SDS Plus-V II 10/200/260 XP10	531866	10	200	260	Plastic tube	10	1
SDS Plus-V II 10/250/310 XP10	531867	10	250	310	Plastic tube	10	1
SDS Plus-V II 12/110/160 XP10	531868	12	110	160	Plastic tube	10	1
SDS Plus-V II 12/160/210 XP10	531869	12	160	210	Plastic tube	10	1
SDS Plus-V II 12/210/260 XP10	531870	12	210	260	Plastic tube	10	1

Masonry drill bit Pointer M

The perfect drill bit for all perforated building materials



Applications

To create drill holes in:

- Hollow bricks
- Aerated concrete
- Perforated sand-lime bricks

Ideal for:

- Frame-fixings or ETICS systems e.g. SXRL, FIS HK, fischer Thermax, EWI and VBS-M

Advantages

- Shortened SDS-Plus shank reduces the impact of the machine on the drill and prevents possible damage to the substrate (it is recommended to use the drill bit without impact).
- Precise and accurate drill holes without damage to the substrate thanks to shortened SDS-Plus shank to guarantee correct fixing with increased load capac-

ities in all types of perforated building materials.

- Diamond sharpened carbide tip with advanced cutting edges ensure fast and safe drilling progress in different materials.
- Large spiral flutes for optimal removal of dust.

Characteristics



Technical data

Masonry drill bit Pointer M



Pointer M

Item	Item No.	Drill hole diameter d_0 [mm]	Working length [mm]	Total length l [mm]	Type of packaging	Contents [pcs]	Sales unit [pcs]
Pointer M 6/350/410	546204	6	350	410	Pouch	1	1
Pointer M 8/200/260	544382	8	200	260	Pouch	1	1
Pointer M 8/100/400	517690	8	100	400	Pouch	1	1
Pointer M 10/200/260	543630	10	200	260	Pouch	1	1
Pointer M 12/200/260	543631	12	200	260	Pouch	1	1
Pointer M 14/200/260	543632	14	200	260	Pouch	1	1
Pointer M 16/200/260	543633	16	200	260	Pouch	1	1
Pointer M 16/100/400	543634	16	100	400	Pouch	1	1
Pointer M 18/350/410	546205	18	350	410	Plastic tube	1	1
Pointer M 20/100/400	543635	20	100	400	Plastic tube	1	1
Pointer M 22/350/410	546206	22	350	410	Plastic tube	1	1

Hammer drill bit SDS Max II / SDS Max IV

The hammer drill bits with SDS Max drill chuck



Applications

To create approval-compliant drill holes in:

- Reinforced concrete (SDS Max IV)
- Concrete
- Solid brick
- Sand-lime brick

Also suitable for:

- Natural stone

Advantages

- The SDS Max drill chuck ensures optimum transfer of force and allows for quick drilling progress for large volume drill holes.
- The drill bit head with four cutting edges prevents jamming in the concrete reinforcement.
- The quadruple flute reliably transports

the drilling dust from the drill hole, thus reducing wear.

- The core-reinforced flute ensures maximum transfer of energy, and guarantees a low-vibration drilling.
- The PGM®-compliant cutting element guarantees perfect-fit drill holes to fulfil the highest safety requirements.

Characteristics



Technical data

Hammer drill bit SDS Max II / SDS Max IV



Hammerdrill SDS Max II and IV

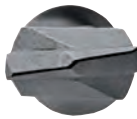

Detail:
Top of drill SDS Max II
Ø 12 - 15 mm



Detail:
Top of drill SDS Max IV
from Ø 16 mm

Item	Item No.	Drill hole diameter d ₀ [mm]	Working length [mm]	Total length l [mm]	Type of packaging	Contents [pcs]	Sales unit [pcs]
SDS Max II 12/200/340	504188	12	200	340	Plastic tube	1	1
SDS Max IV 12/200/340	524556	12	200	340	Plastic tube	1	1
SDS Max II 12/400/540	504189	12	400	540	Plastic tube	1	1
SDS Max IV 12/400/540	524557	12	400	540	Plastic tube	1	1
SDS Max II 14/200/340	504192	14	200	340	Plastic tube	1	1
SDS Max IV 14/200/340	524559	14	200	340	Plastic tube	1	1
SDS Max II 14/400/540	504194	14	400	540	Plastic tube	1	1
SDS Max IV 14/400/540	524560	14	400	540	Plastic tube	1	1
SDS Max II 15/200/340	504196	15	200	340	Plastic tube	1	1
SDS Max IV 15/400/540	524562	15	400	540	Plastic tube	1	1
SDS Max IV 16/200/340	504198	16	200	340	Plastic tube	1	1
SDS Max IV 16/400/540	504199	16	400	540	Plastic tube	1	1
SDS Max IV 16/800/920	504200	16	800	920	Plastic tube	1	1
SDS Max IV 16/1200/1320	504206	16	1200	1320	Plastic tube	1	1
SDS Max IV 18/200/340	504207	18	200	340	Plastic tube	1	1
SDS Max IV 18/400/540	504208	18	400	540	Plastic tube	1	1
SDS Max IV 18/800/940	504209	18	800	940	Plastic tube	1	1
SDS Max IV 18/1200/1320	504213	18	1200	1320	Flexipack	1	1
SDS Max IV 20/200/320	504214	20	200	320	Plastic tube	1	1
SDS Max IV 20/400/520	504217	20	400	520	Plastic tube	1	1
SDS Max IV 20/800/920	504222	20	800	920	Plastic tube	1	1
SDS Max IV 20/1200/1320	504223	20	1200	1320	Flexipack	1	1
SDS Max IV 22/200/320	504224	22	200	320	Plastic tube	1	1
SDS Max IV 22/400/520	504225	22	400	520	Plastic tube	1	1
SDS Max IV 22/800/920	504226	22	800	920	Plastic tube	1	1
SDS Max IV 22/1200/1320	504227	22	1200	1320	Flexipack	1	1
SDS Max IV 24/200/320	504228	24	200	320	Plastic tube	1	1
SDS Max IV 24/400/520	504229	24	400	520	Plastic tube	1	1
SDS Max IV 25/200/320	504235	25	200	320	Plastic tube	1	1
SDS Max IV 25/400/520	504236	25	400	520	Plastic tube	1	1
SDS Max IV 25/800/920	504237	25	800	920	Plastic tube	1	1
SDS Max IV 25/1200/1320	504238	25	1200	1320	Flexipack	1	1
SDS Max IV 25/2000/2120	098287	25	2000	2120	Flexipack	1	1
SDS Max IV 26/400/520	504239	26	400	520	Plastic tube	1	1
SDS Max IV 28/250/370	504240	28	250	370	Plastic tube	1	1
SDS Max IV 28/450/570	504241	28	450	570	Plastic tube	1	1
SDS Max IV 28/550/670	504242	28	550	670	Plastic tube	1	1
SDS Max IV 28/800/920	504243	28	800	920	Plastic tube	1	1
SDS Max IV 30/250/370	504245	30	250	370	Plastic tube	1	1
SDS Max IV 30/450/570	504246	30	450	570	Plastic tube	1	1
SDS Max IV 30/800/920	057779	30	800	920	Plastic tube	1	1
SDS Max IV 32/450/570	504248	32	450	570	Plastic tube	1	1
SDS Max IV 32/800/920	504249	32	800	920	Plastic tube	1	1
SDS Max IV 35/250/370	504251	35	250	370	Plastic tube	1	1
SDS Max IV 35/450/570	504256	35	450	570	Plastic tube	1	1
SDS Max IV 35/550/670	504257	35	550	670	Plastic tube	1	1
SDS Max IV 35/800/920	504258	35	800	920	Plastic tube	1	1
SDS Max IV 35/1200/1320	504259	35	1200	1320	Flexipack	1	1

1) delivery on request

Technical data

Hammer drill bit SDS Max II / SDS Max IV



Hammerdrill SDS Max II
and IV

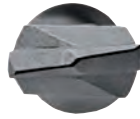

Detail:
Top of drill SDS Max II
Ø 12 - 15 mm



Detail:
Top of drill SDS Max IV
from Ø 16 mm

Item	Item No.	Drill hole diameter d_0 [mm]	Working length [mm]	Total length l [mm]	Type of packaging	Contents [pcs]	Sales unit [pcs]
SDS Max IV 35/1620/1740	040191	35	1620	1740	Flexipack	1	1
SDS Max IV 35/2000/2140	040192 ¹⁾	35	2000	2140	Flexipack	1	1
SDS Max IV 38/450/570	504268	38	450	570	Plastic tube	1	1
SDS Max IV 40/250/370	504269	40	250	370	Plastic tube	1	1
SDS Max IV 40/450/570	504270	40	450	570	Plastic tube	1	1
SDS Max IV 40/800/920	504271	40	800	920	Plastic tube	1	1
SDS Max IV 40/1200/1320	504272	40	1200	1320	Flexipack	1	1
SDS Max IV 45/450/570	504274	45	450	570	Tube	1	1
SDS Max IV 45/800/920	504275	45	800	920	Tube	1	1
SDS Max IV 52/450/570	504276	52	450	570	Tube	1	1

1) delivery on request

Hollow drill bit FHD

Hollow drill bit for drilling with low dust as well as for efficient and approved anchoring



Applications

To create approval-compliant drill holes in:

- Reinforced concrete
- Concrete

Also suitable for:

- Solid brick
- Solid sand-lime brick
- Natural stone

Advantages

- Drilling and drill hole cleaning in one single step saves the normal cleaning of chemical and mechanical anchoring when the hollow drill bit is regulated by their respective approvals. This saves up to 55% of the complete drill hole creation process.
- The drill hole will be cleaned thoroughly guaranteeing a secure fixing (drilling dust reduces performance of fixing materials).
- Reducing the drill dust prevents jamming when drilling therefore provides a faster and frictionless drilling progress.
- Immediate extraction of drilling dust at the drill tip for a clean and healthy work place.
- Centering tip allows for accurate positioning on uneven surfaces reducing slip.

Characteristics



Technical data

Hollow drill bit FHD



FHD



Detail:
Top of drill FHD
Ø 12 - 14 mm



Detail:
Top of drill FHD
Ø 16 - 18 mm
Top of drill FHD Max
Ø 16 - 35 mm

Item	Item No.	Drill hole diameter d_0 [mm]	Working length [mm]	Total length l [mm]	Type of packaging	Contents	Sales unit [pcs]
FHD 12/200/330	546597	12	200	330	Plastic clip	1	1
FHD 14/250/380	546598	14	250	380	Plastic clip	1	1
FHD 16/250/380	546599	16	250	380	Plastic clip	1	1
FHD 18/320/450	546600	18	320	450	Plastic clip	1	1
FHD Max 16/400/620	546601	16	400	620	Plastic clip	1	1
FHD Max 18/400/620	546602	18	400	620	Plastic clip	1	1
FHD Max 20/400/620	546603	20	400	620	Plastic clip	1	1
FHD Max 24/400/620	546604	24	400	620	Plastic clip	1	1
FHD Max 28/600/820	546605	28	600	820	Plastic clip	1	1
FHD Max 30/600/820	546606	30	600	820	Plastic clip	1	1
FHD Max 35/650/870	546607	35	650	870	Plastic clip	1	1

Stone drill bit D-S

Universal masonry drill bit for impact and rotary drilling in masonry and natural stone



Applications

- For regular drilling especially in stone and masonry

Advantages

- 130° carbide cutting edge for long service life, very heat resistant.
- Robust version in accordance with DIN 8039, roll forged.
- Optimum drill dust removal through special spiral geometry.
- Suitable for rotary and impact drilling.

Characteristics



Technical data

Stone drill bit D-S



D-S

Item	Item No.	Drill hole diameter d_0 [mm]	Working length [mm]	Total length l [mm]	Type of packaging	Contents [pcs]	Sales unit [pcs]
D-S HM 3,0x30/60 PE	542976	3	30	60	Pouch	1	1
D-S HM 4,0x38/75 PE	542977	4	38	75	Pouch	1	1
D-S HM 5,0x44/85 PE	542978	5	44	85	Pouch	1	1
D-S HM 6,0x54/100 PE	542979	6	54	100	Pouch	1	1
D-S HM 6,0x135/200 PE	551390	6	135	200	Pouch	1	1
D-S HM 7,0x54/100 PE	542980	7	54	100	Pouch	1	1
D-S HM 8,0x67/120 PE	542981	8	67	120	Pouch	1	1
D-S HM 8,0x135/200 PE	542991	8	135	200	Pouch	1	1
D-S HM 10,0x135/200 PE	542992	10	135	200	Pouch	1	1
D-S HM 10,0x67/120 PE	542982	10	67	120	Pouch	1	1
D-S HM 12,0x85/150 PE	542983	12	85	150	Pouch	1	1
D-S HM 12,0x135/200 PE	542993	12	135	200	Pouch	1	1
D-S HM 13,0x85/150 PE	542984	13	85	150	Pouch	1	1
D-S HM 14,0x85/150 PE	542985	14	85	150	Pouch	1	1
D-S HM 15,0x85/150 PE	542986	15	85	150	Pouch	1	1
D-S HM 16,0x85/150 PE	542987	16	85	150	Pouch	1	1
D-S HM 18,0x100/160 PE	542988	18	100	160	Pouch	1	1
D-S HM 20,0x100/160 PE	542989	20	100	160	Pouch	1	1
D-S Set 4-10mm 5pcs P	543025	4-5-6-8-10	—	—	Plastic cassette	5	1
D-S Set 3-10mm 8pcs P	543027	3-10	—	—	Plastic cassette	8	1

Premium chisel FCP

Premium Chisel with SDS Plus and SDS Max shank for maximum performance and lifetime



Applications

Suitable for creating holes, slots and installation paths as well as breakthroughs in:

- Concrete
- Masonry
- Natural stone

Advantages

- Extended working tip in comparison to the standard chisel for an increased lifetime.
- Self-sharpening design for economical working and reducing downtime.
- Advanced 'jam protection' for reduced friction.
- Specially designed working tip increases the performance and ensures a high removal of material.

Characteristics



Technical data

Premium chisel FCP						
Item	Item No.	Type	Length L [mm]	Width B [mm]	Contents [pcs]	Sales unit [pcs]
FCP Pointed 250	546314	Pointed	250	—	1	1
FCP Flat 20/250	546315	Flat	250	20	1	1
FCP Spade 40/250	546316	Spade	250	40	1	1
FCP Max Pointed 400	546317	Pointed	400	—	1	1
FCP Max Flat 25/400	546318	Flat	400	25	1	1
FCP Max Spade 50/380	546319	Spade	380	50	1	1
FCP Set	546320	Pointed, Flat, Spade	—	—	3	1
FCP Max Set	546321	Pointed, Flat, Spade	—	—	3	1

Standard chisel



Applications

Suitable for creating holes, slots and installation paths in:

- Concrete
- Masonry
- Natural stone

Advantages

- The SDS Plus and SDS Max drill chuck for the chisel enable the use with professional hammer drilling machines and ensure proven and safe transfer of force.
- The use of a high quality, specially hardened steel with surface protection increases the life span of the tools.
- The high oscillation endurance allows for high work comfort and contributes to the achievement of clean results.

Characteristics



Technical data

Standard chisel

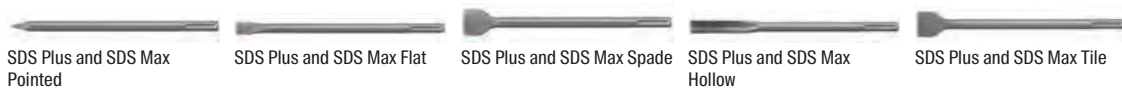

Item	Item No.	Type	Length L [mm]	Width B [mm]	Contents [pcs]	Sales unit [pcs]
SDS Plus and SDS Max Pointed						
SDS Plus Pointed 250	504277	Pointed	250	12	1	1
SDS Max Pointed 280	504281	Pointed	280	16	1	1
SDS Max Pointed 400	504282	Pointed	400	20	1	1
SDS Max Pointed 600	504283	Pointed	600	27	1	1
SDS Plus Flat 20/250	504278	Flat	250	20	1	1
SDS Max Flat 25/280	504284	Flat	280	25	1	1
SDS Max Flat 25/400	504286	Flat	400	25	1	1
SDS Max Flat 25/600	504287	Flat	600	25	1	1
SDS Plus Scaling 40/250	504279	Spade	250	40	1	1
SDS Max Scaling 50/400	504288	Spade	400	50	1	1
SDS Max Scaling 80/300	504290	Spade	300	80	1	1
SDS Max Scaling 115/350	504291	Spade	350	115	1	1
SDS Plus Hollow 22/250	504280	Hollow	250	22	1	1
SDS Max Hollow 26/300	504293	Hollow	300	26	1	1
SDS Plus Tile scaling 40/250	531437	Tile scaling	250	40	1	1
SDS Max Tile Scaling 50/400	504295	Tile scaling	400	50	1	1

ProfiBit FPB

The all-rounding bit within convincing quality



Advantages

- The bits manufactured from special steel with high hardness degree are suitable for both hand driven and machine guided applications.
- The perfect fitting inside screws ensures working with low-wear of the product and consequently long lifetime and clean working results.
- The profile guarantees an ideal connection for an optimal power and torque transmission that prevents damages of the surface or the screw-heads.
- Also available as clearly arranged bit-set with 10 or 32pcs including bit holder.

Applications

Number of internal drives in various profile sizes, such as:

- PH, PZ cross-slot
- TX star recess
- Suitable for ¼" drives

Technical data

ProfiBit FPB



Item	Item No.	Drive	Length L [mm]	Contents	Sales unit [pcs]
FPB TX 25 ProfiBit W5	517693	TX25	50	5	1
FPB TX 30 90 mm ProfiBit W1	542369	TX30	90	1	1
FPB TX 30 150 mm ProfiBit W1	542372	TX30	150	1	1
FPB TX 40 90 mm ProfiBit W1	542370	TX40	90	1	1
FPB TX 40 150 mm ProfiBit W1	542373	TX40	150	1	1
FPB TX 50 ProfiBit W1	557839	TX50	25	1	1
FPB TX 50 90 mm ProfiBit W1	542371	TX50	90	1	1
FPB PH 2 Drywall W 1	557840	PH 2	25	1	1
FPB PZ 2 50mm ProfiBit W1	557842	PZ2	50	1	1
FPB PZ 4 ProfiBit W1	557843	PZ 4	38	1	1
FPB TX 10 ProfiBit W10	557845	TX10	25	10	1
FPB TX 15 ProfiBit W10	557846	TX15	25	10	1
FPB TX 20 ProfiBit W10	557847	TX20	25	10	1
FPB TX 25 ProfiBit W10	557848	TX25	25	10	1
FPB TX 30 ProfiBit W10	557849	TX30	25	10	1
FPB TX 40 ProfiBit W10	557850	TX40	25	10	1
FPB PH 1 ProfiBit W10	557851	PH1	25	10	1
FPB PH 2 ProfiBit W10	557852	PH 2	25	10	1
FPB PH 3 ProfiBit W10	557853	PH3	25	10	1
FPB PZ 1 ProfiBit W10	557854	PZ1	25	10	1
FPB PZ 2 ProfiBit W10	557855	PZ2	25	10	1
FPB PZ 3 ProfiBit W10	557856	PZ3	25	10	1

DiamondBit FDB

The non-slip bit



Advantages

- The coating with diamond-particles ensures the best possible power-transfer and prevents the bit tip from slipping out of the screw head.
- The diamond-coated bit with a high hardness grade guarantees the greatest service life and corrosion resistance.
- The torsion zones created by the tapered bit cross-section offers relief in the case of extreme loads. For a more effortless installation and maximum operating efficiency.
- The high dimensional accuracy enables an optimum bit fit for clean results and a long lifetime.

Applications

Number of internal drives in various profile sizes, such as:

- PH, PZ cross-slot
- TX star recess
- Suitable for ¼" drives

Technical data

DiamondBit FDB



Item	Item No.	Drive	Length L [mm]	Contents	Sales unit [pcs]
FDB TX 10 DiamondBit W10	557857	TX10	25	10	1
FDB TX 15 DiamondBit W10	557858	TX15	25	10	1
FDB TX 20 DiamondBit W10	557859	TX20	25	10	1
FDB TX 25 DiamondBit W10	557860	TX25	25	10	1
FDB TX 30 DiamondBit W10	557861	TX30	25	10	1
FDB TX 40 DiamondBit W10	557862	TX40	25	10	1
FDB PH 1 DiamondBit W10	557863	PH1	25	10	1
FDB PH 2 DiamondBit W10	557864	PH 2	25	10	1
FDB PH 3 DiamondBit W10	557865	PH3	25	10	1
FDB PZ 1 DiamondBit W10	557866	PZ1	25	10	1
FDB PZ 2 DiamondBit W10	557867	PZ2	25	10	1
FDB PZ 3 DiamondBit W10	557868	PZ3	25	10	1

MaxxBit FMB

The ultimate torsion-bit



Advantages

- The ultimate solution for extreme installation torques. Ideal for usage in high-performance power and impact tools.
- Optimal geometry of the profile guarantees unique performance and durability for sophisticated applications and users.
- The elastic torsion zone releases at extreme loads to ensure a gentle working and maximum operating efficiency.
- The high dimensional accuracy allows for an ideal fit. For clean results and a long lifetime.

Applications

Number of internal drives in various profile sizes, such as:

- TX star recess
- Suitable for ¼" drives

Technical data

MaxxBit FMB



FMB TX

Item	Item No.	Drive	Length L [mm]	Contents	Sales unit [pcs]
FMB TX10 MaxxBit W 5	533154	TX10	29	5	1
FMB TX15 MaxxBit W 5	533155	TX15	29	5	1
FMB TX20 MaxxBit W 5	533156	TX20	29	5	1
FMB TX25 MaxxBit W 5	533157	TX25	29	5	1
FMB TX30 MaxxBit W 5	533158	TX30	29	5	1
FMB TX40 MaxxBit W 5	533159	TX40	29	5	1

BitHolder FBH

The bit holder for rapid bit exchange



Advantages

- The bit holder family for 1/4" bits with magnetic insert hold the bit securely in the drill chuck and offers a smooth installation procedure.
- Robust and slim bit holder for an easy bit exchange.
- Ideal for direct machine connection or enlargement of the bits to reach difficult areas.
- With the FBH QuickBit Slim the bit automatically locked when plugged in and provides a secure hold. By pulling back the sleeve the bit can be easily taken out.

Applications

- The bit holders for use in cylinder drill chucks

Using the BitHolder FBH

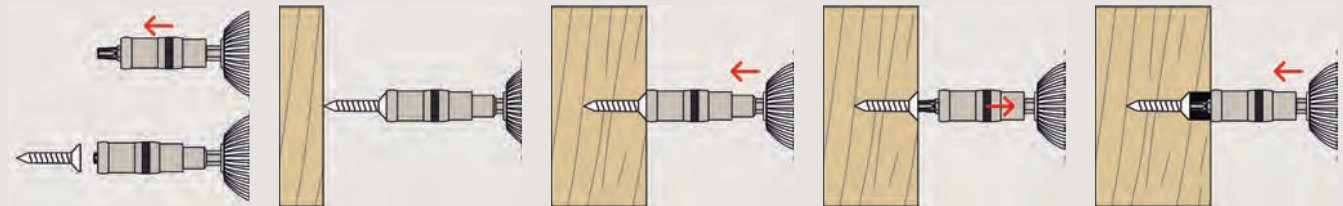

Technical data

BitHolder FBH



FBH BitHolder

FBH QuickBit Slim

Item	Item No.	Drive	Length L [mm]	Contents [pcs]	Sales unit [pcs]
FBH BitHolder W1	558178	1/4"	58	1	1
FBH QuickBit Slim W1	533150	1/4"	50	1	1

BitSet

Useful bit sets for a multitude of applications



Advantages

- Universal use with most common bits as well as a bit holder in one set.
- Compact bit sets with easy handling.
- Safe and clearly arranged keeping of the

- content assuring a reliable usage.
- Robust and durable construction fulfilling even hardest requirements.

Applications

- The ideal bit sets for quick and efficient working
- For a high variation of applications

Technical data

BitSet



BitSet FPB Profi W10



BitSet FPB Profi W32

Item	Item No.	Contents	Sales unit [pcs]
FPB BitSet Profi W10	558179	each 1x PZ1, PZ2, PZ3, TX10, TX15, TX20, TX25, TX30, TX40, 1x Universal bit holder	1
FPB BitSet Profi W32	559121	2x PZ1, 4x PZ2, 2x PZ3, 1x TX8, 2x TX10, 1x TX15, 2x TX20, 2xTX25, 1x TX27, 1x TX30, 1x TX40, 2x PH1, 4x PH2, 2x PH3, 1x PH2 D, 1x SL4.5, 1x SL5.5, 1x SL6, 1x Universal bit holder	1

Accessories for impact driver

Ideal for use in high-performance power- and impact-tools



Advantages

- Optimal geometry of the profile guarantees unique performance and durability for complex applications and users.
- The high dimensional accuracy allows for an ideal fit. For clean results and a long lifetime.

Applications

- The ultimate solution for extreme installation torques

Technical data

Accessories for impact driver



Item	Item No.	Drive	Total length [mm]	Sales unit [pcs]
Nut SW 10	538577	1/2" / SW10	78	1
Nut SW 13	538578	1/2" / SW13	38	1
Nut SW 15	538579	1/2" / SW15	38	1
Nut SW 17	538580	1/2" / SW17	38	1
Nut SW 21	538581	1/2" / SW21	38	1
Nut 1/2" - 1/4"	553928	1/2" / 1/4"	55	1
Nut 1/2" - TX 50	553929	1/2" / TX50	55	1
FPB TX 50 5/16" ProfiBit	557844	TX50	35	1

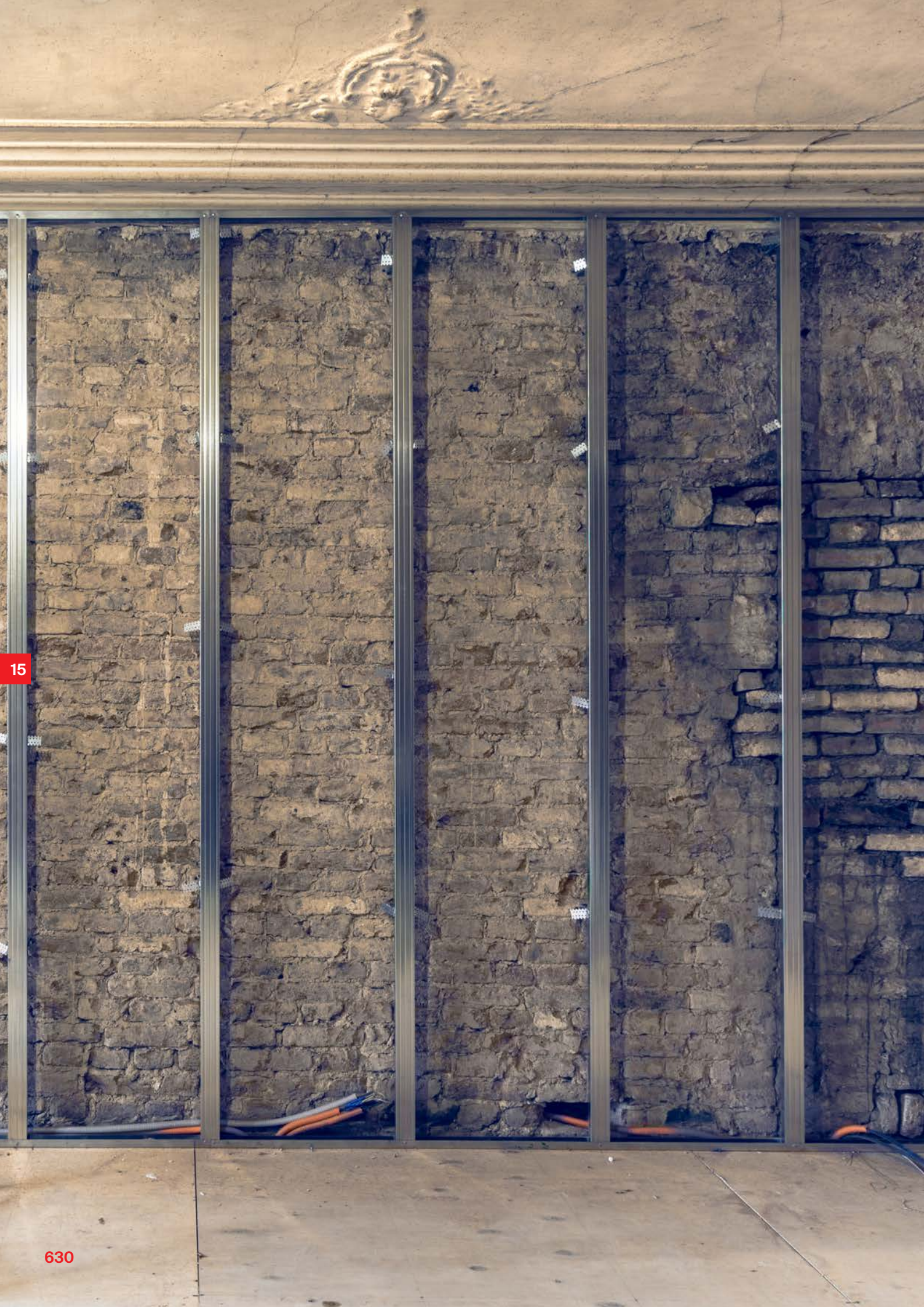

15

630

15

Power tools

Cordless impact wrenches FSS 18V 632



Vacuum cleaner FVC 35M 635



Gas actuated fastening tool FGC 100 638



Cordless impact wrenches FSS 18V

The specialists for concrete screws.



Column feet



Balcony railings

Applications

- Anchoring of railings
- Column bases
- Pipeline routes
- Canopies
- Shelving systems
- Steel-steel connections
- Tyre changes

Advantages

- The tangential impact wrenches FSS 18V are compatible with all Cordless Alliance System (CAS) chargers and rechargeable batteries worldwide.
- The FSS 18V guarantee low-vibration despite an extremely high torque.
- The additionally accessories supplied as sockets and checking gauges, enable ease of installation and checking for reusability of the concrete screws FBS II gvz.
- The tools are delivered in the compatible L-Boxx, which can be connected by a click system.

- Powerful rechargeable battery (4.0 Ah) with lithium-ion power and integrated capacity indicator to check the state of charge.

Additional advantages FSS 18V 400 BL:

- The 12 levels of regulation allow the torque of the FSS 18V 400 BL to be individually adapted to the application.
- The brushless motor has an overheat protection that increases safety while reducing downtime and wear.

Certificates



Versions

- FSS 18V 400 BL: Torque 400 Nm
- FSS 18V 600: Torque 600 Nm

Functioning

- The fischer cordless impact wrenches FSS 18V are perfectly suited for the installation of fischer UltraCut concrete screws FBS II of all diameters.
- Depending on the head shape of the concrete screw, either an appropriate socket or a special torx bit is recommended for the installation.
- The concrete screw is first screwed in and then tightened by the percussion mechanism.
- If the screw head is in contact with the attachment, correct assembly of the concrete screw is guaranteed (optical setting check).

Technical data

Cordless impact wrenches FSS



FSS 18V 400 BL

FSS 18V 600

Item	Item No.	Belt hook FSS BH	Sockets [SW]		Test sleeves FUP for concrete screw diameter		Battery pack 4.0 Ah		Charger		Packaging L-Boxx, stackable
			10 / 13 / 15	15 / 17 / 21	8 / 10	12 / 14	1x	2x	Type EU	Type UK	
FSS 18V 400 BL - Set 1	552922	●	●		●						●
FSS 18V 400 BL - Set 2	552924	●	●		●		●				●
FSS 18V 400 BL - Set 3	552926	●	●		●			●	●		●
FSS 18V 400 BL - Set 4	552928	●	●		●			●		●	●
FSS 18V 600 - Set 1	552923	●		●		●					●
FSS 18V 600 - Set 2	552925	●		●		●	●				●
FSS 18V 600 - Set 3	552927	●		●		●		●	●		●
FSS 18V 600 - Set 4	552929	●		●		●		●		●	●

Technical data

Cordless impact wrenches FSS



FSS 18V 400 BL

FSS 18V 600

Item	Battery voltage	Max. idle speed	Max. number of strokes	Max. torque	Torque levels	Tool mounting	Vibration impact screws	Sound power level ¹⁾	Sound pressure level ²⁾ (LwA)	Weight with battery
	[V]	[/min]	[/min]	[Nm]			(m/s ²)	[dB (A)]	[dB (A)]	[kg]
FSS 18V 400 BL	18	0-2150	4250	400	12	outer square 1/2" (12,7 mm)	12 ¹⁾	111	100	1,9
FSS 18V 600	18	0-1600	2200	600	1	outer square 1/2" (12,7 mm)	5,9 ²⁾	107	96	3,1

1) Measurement uncertainty K --> 1,5 m/s²

2) Measurement uncertainty K --> 5,9 m/s²

3) Measurement uncertainty K --> 3,0 dB(A)

Accessories

FSS-B and FSS-BC



FSS-B 4.0Ah Battery

FSS-BC Battery charger, air-cooled

Item	Item No.	CAS-compatible	Type of battery	Battery capacity [Ah]	Mains voltage [V]	Mains frequency [Hz]	Max. charge amperage [A]	Weight of battery [g]	Suitable for battery voltage [V]	Storage & processing [°C]	Air humidity [%]	Vibration & Shock impact [G]
FSS-B 18V 4.0Ah	552930	1) ●	Lithium-Ion	4.0	-	-	-	670	-	-20 - +60	< 90	< 5
FSS-BC 12-36V EU	552931	1) ●	-	-	230-240	50-60	3	-	12-36	-	-	-
FSS-BC 12-36V UK	552932	1) ●	-	-	230-240	50-60	3	-	12-36	-	-	-

1) Battery may only be charged with fischer or CAS chargers.

Accessories

Accessories



FUP

Nut SW

Nut 1/2" - 1/4"

MaxxBit FMB TX

FPB ProfiBit TX 50 5/16"

Item	Item No.	Internal diameter [mm]	Drive	Match	Sales unit [pcs]
FUP 8	537200	9,9	—	FBS II 8	1
FUP 10	537201	12,0	—	FBS II 10	1
FUP 12	537202	13,0	—	FBS II 12	1
FUP 14	537203	15,0	—	FBS II 14	1
Nut SW 10	538577	—	1/2" / SW10	FBS II 6	1
Nut SW 13	538578	—	1/2" / SW13	FBS II 8	1
Nut SW 15	538579	—	1/2" / SW15	FBS II 10	1
Nut SW 17	538580	—	1/2" / SW17	FBS II 12	1
Nut SW 21	538581	—	1/2" / SW21	FBS II 14	1
Nut 1/2" - 1/4"	553928	—	1/2" / 1/4"	FBS II 6 / FBS II 8 / FBS II 8 SK	1
Nut 1/2" - TX 50	553929	—	1/2" / TX50	FBS II 10 / FBS II 10 SK	1
FMB TX30 MaxxBit W 5	533158	—	TX30	FBS II 6	1
FMB TX40 MaxxBit W 5	533159	—	TX40	FBS II 6 / FBS II 8 / FBS II 8 SK	1
FPB TX 50 5/16" ProfiBit	557844	—	TX50	FBS II 10 SK	1

Vacuum cleaner FVC 35 M

Universal wet and dry vac for virtually dust free applications.



Hollow drilling



Wet vacuuming

Applications

Suitable for:

- Dry suction
- Wet suction

As suction system for:

- Hollow drill bits
- Sawing machines
- Grinding machines
- Milling machines

Certificates



Advantages

- Automatic filter cleaning during suction operation without any interruption enables non-stop suction.
- Vacuum cleaner filter with dust retention capacity of 99,9 % according to dust class M, perfectly suited for use with the fischer hollow drill bit FHD.

Versions

- FVC 35 M
- FVC 35 M UK

- High performance motor for constantly high suction power.
- Matching cleaning set FVC AP enables dry and wet suction work.
- Sealable filter bags guarantee a dust-free disposal.

Functioning

- The power cable of the electrical device is plugged into the socket of the vacuum cleaner. This means that the vacuum cleaner only runs during the use of the device. The left switch can be used to adjust the suction power according to the device used.
- When the filter bag is full, the lamp to the right of the switches lights up. To change the bag, remove the top container, close the filter bag and replace it without generating any dust.

Technical data

Vacuum cleaner FVC 35 M



FVC 35 M

Item	Item No.	Voltage [V]	Max. power from suction cup to socket [Watt]	Max. power [Watt]	Max. volume flow [l/s]	Negative pressure [mbar]	Noise pressure [dB (A)]	Contents	Weight [kg]	Dimensions [cm]
FVC 35 M	551924	220-240	2000 (220 - 240V~)	1400	73*	270*	69	1x Vacuum cleaner FVC 35 M, 1x Suction hose FVC SH, 2x Folded filter cartridges FVC FC, 1x Bag FVC PB	15,5	53 x 40 x 56 (Power cable length: 800)
FVC 35 M UK	558177	110-120	400 (110 - 120V~)	1400	74*	234*	69	1x Vacuum cleaner FVC 35 M UK, 1x Suction hose FVC SH, 2x Folded filter cartridges FVC FC, 1x Bag FVC PB	15,5	53 x 40 x 56 (Power cable length: 800)

* Measured at motor head

Accessories

Vacuum cleaner FVC 35M



Cleaning set FVC AP

Item	Item No.	Adapted for	Material	Contents	Sales unit [pcs]
FVC AP	552058	FVC 35 M	Plastic	1 x Hand tube with supplementary air slide, 30 cm long, Ø 35 mm 2 x Suction tube, 50 cm long, Ø 35 mm 1 x Floor nozzle, 30 cm broad, Ø 35 mm 1 x Crevice nozzle, 22 cm long, Ø 35 mm	1

Accessories

Accessories



Item	Item No.	Adapted for	Material	Dimensions accessories	Contents	Sales unit [pcs]
FVC FB	552059	FVC 35 M	Fleece	For 35 litre plastic container	5 x FVC FB fleece filter bag	1
FVC PB	552060	FVC 35 M	Polyethylene	For 35 litre plastic container	5 x polyethylene emptying bag FVC PB	1
FVC FC	552061	FVC 35 M	Polyester	Filter surface 8600 cm ²	2 x FVC FC filter cartridges	1
FVC SH	552062	FVC 35 M	Polyethylene	Ø 35 mm, length 5 m	1 x suction hose Ø 35 mm, length 5 m	1
FVC PH	552063	FVC 35 M	Stainless steel	—	1 x Push handle FVC PH	1

Accessories

Hollow drill bit FHD



Hollow drill bit FHD

Detail:
Top of drill FHD
Ø 12 - 14 mm

Detail:
Top of drill FHD
Ø 16 - 18 mm
Top of drill FHD Max
Ø 16 - 35 mm

Item	Item No.	Drill hole diameter d_0 [mm]	Working length [mm]	Total length l [mm]	Contents	Sales unit [pcs]
FHD 12/200/330	546597	12	200	330	1	1
FHD 14/250/380	546598	14	250	380	1	1
FHD 16/250/380	546599	16	250	380	1	1
FHD 18/320/450	546600	18	320	450	1	1
FHD Max 16/400/620	546601	16	400	620	1	1
FHD Max 18/400/620	546602	18	400	620	1	1
FHD Max 20/400/620	546603	20	400	620	1	1
FHD Max 24/400/620	546604	24	400	620	1	1
FHD Max 28/600/820	546605	28	600	820	1	1
FHD Max 30/600/820	546606	30	600	820	1	1
FHD Max 35/650/870	546607	35	650	870	1	1

Gas actuated fastening tool FGC 100

Quick and easy fastening in concrete and steel.



Drywall tracks



Electrical installations

Applications

- Drywall tracks
- Electrical installations
- Composite decks
- Insulation systems
- Light duty building construction applications

Advantages

- The 100 joules power ensures correct penetration into the working surface, even for steel to steel applications.
- Easy nail depth adjustment switch to choose how to set the nails.
- Long lifetime with service intervals after every 20,000 fixings under standard conditions.
- Quick release system for a fast disassembling of the magazine and clearing of

- jammed nails.
- Rechargeable battery with Li-Ion power: 8,000 fixings with one charge.
- Battery-LED status.
- A 10 minutes charge allows to fix at least another 300 nails.
- The FGC 100 is delivered in the practical XL-BOXX, which is fully compatible with the L-BOXX.

15

Certificates



Building materials

- Concrete
- Sand-lime brick
- Solid brick
- Steel

Functioning

- The fischer gas actuated fastening tool FGC 100 is suitable for a fast and reliable installation of e. g. drywall tracks and electrical connections in all directions - on floors, walls and ceilings.
- For optimum installation, the tool must be positioned perpendicularly to the working surface.
- The attached stand gives support but can also be removed to drive nails in narrow areas.
- The tool will operate within the temperature range of -7°C to +50°C.
- The dimensions of the tool are: L 336 mm x W 121 mm x H 404 mm.

Technical data

Gas actuated fastening tool FGC 100



Gas actuated fastening tool FGC 100



Battery charger BC 7.2 V



Li-Ion battery B 7.2 V 2.5 Ah



XL-BOXX

Item	Item No.	Contents	Technical details	Sales unit [pcs]
Set FGC 100 (EU)	553411 ¹⁾	1x fischer gas actuated fastening tool FGC 100, 1x Magazine FGC 100 – M26, 1x Battery charger BC 7.2 V incl. charging plug for EU, 2x Li-Ion battery B 7.2 V 2.5 Ah, 1x Push bar, 2x Hex wrench, 1x XL-BOXX	100 joules setting energy, 4.1 kg with battery, Capacity of 26 nails, curved, Input 100 – 240 V, Output 8.4 V – 2 A, > 8,000 fixings per charge, For the clearance of jammed nails, - Is fully compatible with the L-BOXX	1
Set FGC 100 (UK)	553585 ¹⁾	1x fischer gas actuated fastening tool FGC 100, 1x Magazine FGC 100 – M26, 1x Battery charger BC 7.2 V incl. charging plug for UK, 2x Li-Ion battery B 7.2 V 2.5 Ah, 1x Push bar, 2x Hex wrench, 1x XL-BOXX	100 joules setting energy, 4.1 kg with battery, Capacity of 26 nails, curved, Input 100 – 240 V, Output 8.4 V – 2 A, > 8,000 fixings per charge, For the clearance of jammed nails, - Is fully compatible with the L-BOXX	1
Set FGC 100 (US)	553586 ¹⁾	1x fischer gas actuated fastening tool FGC 100, 1x Magazine FGC 100 – M26, 1x Battery charger BC 7.2 V incl. charging plug for US, 2x Li-Ion battery B 7.2 V 2.5 Ah, 1x Push bar, 2x Hex wrench, 1x XL-BOXX	100 joules setting energy, 4.1 kg with battery, Capacity of 26 nails, curved, Input 100 – 240 V, Output 8.4 V – 2 A, > 8,000 fixings per charge, For the clearance of jammed nails, - Is fully compatible with the L-BOXX	1
Set FGC 100 (AUS)	553587 ¹⁾	1x fischer gas actuated fastening tool FGC 100, 1x Magazine FGC 100 – M26, 1x Battery charger BC 7.2 V incl. charging plug for AUS, 2x Li-Ion battery B 7.2 V 2.5 Ah, 1x Push bar, 2x Hex wrench, 1x XL-BOXX	100 joules setting energy, 4.1 kg with battery, Capacity of 26 nails, curved, Input 100 – 240 V, Output 8.4 V – 2 A, > 8,000 fixings per charge, For the clearance of jammed nails, - Is fully compatible with the L-BOXX	1
Set FGC 100 (AR)	560091 ¹⁾	1x fischer gas actuated fastening tool FGC 100, 1x Magazine FGC 100 – M26, 1x Battery charger BC 7.2 V incl. charging plug for AR, 2x Li-Ion battery B 7.2 V 2.5 Ah, 1x Push bar, 2x Hex wrench, 1x XL-BOXX	100 joules setting energy, 4.1 kg with battery, Capacity of 26 nails, curved, Input 100 – 240 V, Output 8.4 V – 2 A, > 8,000 fixings per charge, For the clearance of jammed nails, - Is fully compatible with the L-BOXX	1
Set FGC 100-M50 (EU-Schuko)	560038 ¹⁾	1x fischer gas actuated fastening tool FGC 100, 1x Magazine FGC 100 – M50, 1x Battery charger BC 7.2 V incl. Schuko charging plug, 2x Li-Ion battery B 7.2 V 2.5 Ah, 1x Push bar, 2x Hex wrench, 1x XL-BOXX	100 joules setting energy, 4.1 kg with battery, Capacity of 50 nails, curved, Input 100 – 240 V, Output 8.4 V – 2 A, > 8,000 fixings per charge, For the clearance of jammed nails, - Is fully compatible with the L-BOXX	1

1) Possibly further variants.

Accessories

Accessories for the fastening tool

Magazine standard
FGC 100-M26Magazine extended
FGC 100-M50Battery charger
BC 7.2 VLi-Ion battery
B 7.2 V 2.5 Ah

Item	Item No.	Technical details	Sales unit [pcs]
Magazine standard FGC 100-M26	553412	Capacity of 26 nails, curved	1
Magazine extended FGC 100-M50	553717	Capacity of 50 nails, curved	1
Battery charger BC 7.2V (EU)	553414 ¹⁾	Input 100-240 V, Output 8.4 V – 2 A	1
Battery charger BC 7.2V (UK)	553588 ¹⁾	Input 100-240 V, Output 8.4 V – 2 A	1
Battery charger BC 7.2V (US)	553589 ¹⁾	Input 100-240 V, Output 8.4 V – 2 A	1
Battery charger BC 7.2V (AUS)	553590 ¹⁾	Input 100-240 V, Output 8.4 V – 2 A	1
Battery charger BC 7.2V (EU-Schuko)	560039 ¹⁾	Input 100-240 V, Output 8.4 V – 2 A	1
Battery charger BC 7.2V (AR)	560092 ¹⁾	Input 100-240 V, Output 8.4 V – 2 A	1
Li-Ion battery B 7.2V 2.5Ah	553415	> 8,000 fixings per charge	1

¹⁾ Country specific charging plug. Possibly further variants.

Accessories

Accessories for fixings



Standard nail DFN



High performance nail DFNH

Item	Item No.	Length [mm]	Technical details	Contents
Standard nail DFN 17	553417	17	Gvz with 5 µm coating thickness, for soft concrete < C30/37, shaft diameter 2.6 mm, nail length 17 mm	1,008 nails + 1 fuel cell
Standard nail DFN 20	553418	20	Gvz with 5 µm coating thickness, for soft concrete < C30/37, shaft diameter 2.6 mm, nail length 20 mm	1,008 nails + 1 fuel cell
Standard nail DFN 22	553419	22	Gvz with 5 µm coating thickness, for soft concrete < C30/37, shaft diameter 2.6 mm, nail length 22 mm	1,008 nails + 1 fuel cell
Standard nail DFN 25	553420	25	Gvz with 5 µm coating thickness, for soft concrete < C30/37, shaft diameter 2.6 mm, nail length 25 mm	1,008 nails + 1 fuel cell
Standard nail DFN 30	553421	30	Gvz with 5 µm coating thickness, for soft concrete < C30/37, shaft diameter 2.6 mm, nail length 30 mm	1,008 nails + 1 fuel cell
Standard nail DFN 32	553422	32	Gvz with 5 µm coating thickness, for soft concrete < C30/37, shaft diameter 2.6 mm, nail length 32 mm	1,008 nails + 1 fuel cell
Standard nail DFN 35	553423	35	Gvz with 5 µm coating thickness, for soft concrete < C30/37, shaft diameter 2.6 mm, nail length 35 mm	1,008 nails + 1 fuel cell
Standard nail DFN 40	553424	40	Gvz with 5 µm coating thickness, for soft concrete < C30/37, shaft diameter 2.6 mm, nail length 40 mm	1,008 nails + 1 fuel cell
High performance nail DFNH 15	553425	15	Gvz with 5 µm coating thickness, for hard concrete ≥ C30/37 and steel, shaft diameter 3.0 mm, nail length 15 mm	1,008 nails + 1 fuel cell
High performance nail DFNH 17	553426	17	Gvz with 5 µm coating thickness, for hard concrete ≥ C30/37 and steel, shaft diameter 3.0 mm, nail length 17 mm	1,008 nails + 1 fuel cell
High performance nail DFNH 22	553427	22	Gvz with 5 µm coating thickness, for hard concrete ≥ C30/37 and steel, shaft diameter 3.0 mm, nail length 22 mm	1,008 nails + 1 fuel cell
High performance nail DFNH 27	553428	27	Gvz with 5 µm coating thickness, for hard concrete ≥ C30/37 and steel, shaft diameter 3.0 mm, nail length 27 mm	1,008 nails + 1 fuel cell
High performance nail DFNH 32	553429	32	Gvz with 5 µm coating thickness, for hard concrete ≥ C30/37 and steel, shaft diameter 3.0 mm, nail length 32 mm	1,008 nails + 1 fuel cell

Accessories

Accessories for fixings



Fuel cell
FC 165



EWI plug
TFD



EWI nose
FGC 100 - N EWI



Magnetic nose piece supple-
ment FGC 100 - N magnetic

Item	Item No.	Length [mm]	Technical details	Contents
Fuel cell FC 165	553416	165	For more than 1,100 fixings	—
EWI plug TFD 30	554928	30	To fix insulation material with a thickness of 50 mm, on soft concrete < C30/37 with DFN 40	504
EWI plug TFD 50	554929	50	Gvz with 5 µm coating thickness, for hard concrete ≥ C30/37 and steel, shaft diameter 3.0 mm, nail length 32 mm	504
EWI nose FGC 100-N EWI	554869	—	For the use of fischer EWI plugs TFD 30 and TFD 50	1
Magnetic nose piece supplement FGC 100-N magnetic	553715	—	For the use with metal washers	2
Metal washer FGC 100	554935	—	It prevents fixture pull-over and is used with the magnetic nose piece supplement to fix wire mesh or membranes.	1,008
Cleaning kit FGC 100	553718	—	150 ml Cleaner, 100 ml Lubricating Oil and tool rubber sealing rings	1

Loads

Standard nails DFN and high-performance nails DFNH

Recommended loads¹⁾ of a single nail in the respective building material as multiple use with at least 6 nails per attachment part.

Building material	Setting depth h_{ef} [mm]	Recommended tension load ¹⁾ F_{rec} [kN]	
		DFN	DFNH
Concrete C20/25 ²⁾	≥ 14	0.10	-
	≥ 16	0.18	-
	≥ 18	0.20	0.22
	≥ 20	0.20	0.50
Concrete C50/60 ²⁾	≥ 14	-	0.12
	≥ 17	-	0.18
	≥ 18	-	0.22
Solid sand-lime brick KS DIN EN 771-2 / KS 16 998 x 200 x 623 mm	≥ 20	0.50	-
	≥ 25	0.68	-
	≥ 27	0.80	-
	≥ 29	0.95	-
Solid brick Mz DIN EN 771-1 / Mz 20, DF	≥ 14	0.10	-
	≥ 16	0.16	-
	≥ 18	0.19	-
	≥ 20	0.19	-
Steel S235JR acc. to EN 10025-2	≥ 8	-	0.96
Member thickness and edge distance for concrete			
Minimum member thickness	h_{min} [mm]	60	60
Minimum edge distance	c_{min} [mm]	70	70
Member thickness and edge distance for steel			
Minimum member thickness	h_{min} [mm]	-	4
Minimum edge distance	c_{min} [mm]	-	14
Maximum fixture thickness			
Wood	t_{fix} [mm]	25	25
Metal sheet	t_{fix} [mm]	2.5	2.5

¹⁾ Required safety factors are considered. Not for safety relevant single point fixings. All visible setting errors must be corrected. Use only in dry areas. To confirm the technical data, setting and load tests are recommended.

²⁾ The load values in concrete are valid for tension and shear load.



16

Basic knowledge of fastening technology

Basic knowledge	643
Building material – Concrete	644
Building material – Masonry	646
Building material – Drywall panels	648
Drilling	650
Installation	651
Installation types	652
Loads	653
Working principles	654
Failure modes	655
Cracks in concrete components	656
Fire protection – Fundamentals	657
Fire protection in fastening technology	658
Corrosion – Fundamentals	659
Corrosion protection	659
Dynamics	660
Legal basis	661
Assessment procedure	662
Design of fastenings	663
Approvals	664

Building material – Concrete.

The substrate's quality is crucial when selecting the correct fixing:



Concrete

A differentiation is made between concrete, masonry and panel building materials. Concrete is made from a mixture of cement, aggregates and water.

Concrete's main properties are:

- High level of compressive strength, but only low tensile strength ($\approx 10\%$ of the compressive strength).
- Inserting individual rebars and or mats will increase tensile strength (steel + concrete = reinforced concrete).
- Structure easily reproducible as it is regulated by standards, therefore it is an ideal anchor base.

Concrete is mainly split into two categories:

- **Standard concrete and lightweight concrete.** While standard concrete contains gravel; lightweight concrete contains additives such as pumice, expanded clay or polystyrene® usually with a lower compressive strength or bulk density. This leads to unfavourable conditions for anchor fixings.
- **The load bearing capacity of heavy duty fixings depends on the concrete's compressive and tensile strength.** This is indicated by the numbers in the abbreviations: e.g. the most commonly used concrete compressive strength is C20/25 with a cube compressive strength of 25 N/mm^2 .

Expert tip

Standard concrete qualities:

C12/15 to C50/60, even higher grades are also available for special applications. The majority of anchors approved for concrete may only be used from concrete quality from C20/25 up to a max. of C50/60. In the past, designations from DIN 1045 were used in Germany: B25 (~ C20/25) to B55 (~ C45/55).

- C = concrete
- 20 = compressive strength f_{ck} or $f_{ck, cyl}$ of a concrete test cylinder ($\varnothing 150 \text{ mm}$, height 300 mm) in N/mm^2
- 25 = compressive strength f_{ck} , cube of a concrete test cube (edge length 150 mm) in N/mm^2

Normal concrete without accelerating additives reaches its nominal strength after 28 days. Only then can the fixing be installed in compliance with the approval/assessment.

Fresh concrete: still workable up to approx. one hour after pouring.

Green concrete: starts to harden after four hours, no longer workable.

New concrete: is hardened after 28 days, however minimum compressive strength not yet reached.

Hard concrete: more than 28 days old, nominal strength reached.

Compressive strength classes in different countries

Country	Specimen	Dimensions ¹⁾ [cm]	Concrete strength class	Unit	Standard
China	Cube	15x15x15	C15, C20, C25, C30, C35, C40, C45, C50, C55, C60	N/mm ²	GB50010-2010
Denmark	Cube	15x15x15	C12/15, C16/20, C20/25, C25/30, C30/37, C40/50, C45/55, C50/60	N/mm ²	DS/EN 206
Germany	Cube	15x15x15	C12/15, C16/20, C20/25, C25/30, C30/37, C40/50, C45/55, C50/60	N/mm ²	EN 206
France	Cylinder	16x32	B20, B25, B30, B35, B40, B45, B50	N/mm ²	BAEL 91
Great Britain	Cube	15x15x15	C20, C25, C30, C37, C40, C45, C55, C60	N/mm ²	BS EN 12390-3:2009
Italy	Cube	15x15x15	C 8/10, C12/15, C16/20, C20/25, C25/30, C28/35, C30/37, C32/40, C35/45, C40/50, C45/55, C50/60	N/mm ²	UNI EN 206
Japan	Cylinder	10x20	≥ 15	N/mm ²	JIS A 1108
Korea	Cylinder	10x20, 15x30	18, 21, 24, 27, 30	N/mm ²	KS F 2405
The Netherlands	Cylinder	15x30	C 8/10, C12/15, C16/20, C20/25, C25/30, C30/37, C35/45, C40/50, C45/55, C50/60	N/mm ²	NEN-EN 206-1
Austria	Cube	15x15x15	C 8/10, C12/15, C16/20, C20/25, C25/30, C30/37, C35/45, C40/50, C45/55, C50/60	N/mm ²	ÖNORM B 4710-1
Sweden	Cube	15x15x15	C12/15, C16/20, C20/25, C25/30, C30/37, C40/50, C45/55, C50/60	N/mm ²	SS-EN206
Switzerland	Cube	15x15x15	C12/15, C16/20, C20/25, C25/30, C30/37, C40/50, C45/55, C50/60	N/mm ²	SIA 262
Spain	Cylinder	15x30	Unreinforced concrete: HM-20, HM-25, HM-30, HM-35, HM-40, HM-45, HM-50 Reinforced concrete: HA-25, HA-30, HA-35, HA-40, HA-45, HA-50 Pre-stressed concrete: HP-25, HP-30, HP-35, HP-40, HP-45, HP-50	N/mm ²	EHE-08
USA	Cylinder	15x30	2000, 2500, 3000, 3500, 4000, 5000, 6000, 7000, 8000	Psi	ACI 318

1) Conversion: $f_{\text{Cylinder}} = 0.85 \times f_{\text{Cube}, 20 \times 20 \times 20}$; $f_{\text{Cube}, 15 \times 15 \times 15} = 1.05 \times f_{\text{Cube}, 20 \times 20 \times 20}$

Expert tip

- **Anchors** used in **new concrete** must be **suitable** for this purpose, or may only bear loads after reaching the minimum compressive strength.
- **Concrete** always shows **cracks** (shrinkage during hardening, loading).
- In **cracked concrete**, anchors which are tested in cracked concrete must be used. These anchors must be able to **expand** when concrete starts to crack e. g., expansion anchors (e. g. FAZ II), form locking anchors or undercut anchors (e. g. FZA), or bonded anchors (e. g. FIS SB).
- **Cutting** through **reinforcement steel** while making **drill holes** is **not permitted**. In special cases, non load-bearing steels can be cut after consultation with the responsible engineer.
- The load bearing capacity of the concrete along the entire drill hole must be guaranteed (no honeycombing in the concrete, no voids and pockets).
- **Pre-stressed concrete**: A certain drilling distance must be maintained from the tensioning strands as stated in the approval/assessment (e. g. FHY, FBS 6 or EA II).

Building material – Masonry.

Compared to concrete, there is a larger variety of masonry building materials.



Solid brick



Solid sand-lime brick

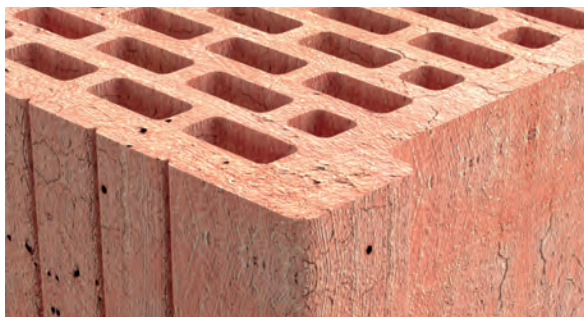

Vertically perforated brick

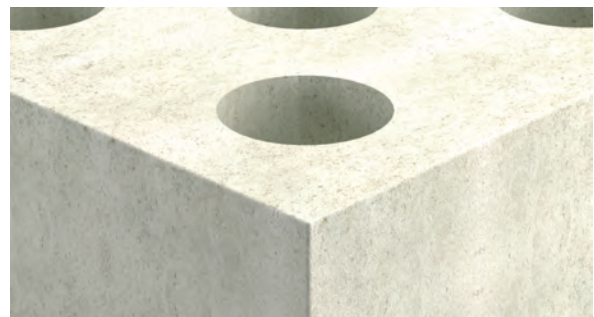

Porous sand brick

16

Masonry can be classified according to:

- brick type used (e. g. natural stone, lime stone or aerated concrete).
- wall type (e. g. single or double layer).
- brick strength class and gross density.

Generally, masonry is classified into four groups:

- 1 Solid bricks with a dense structure are a highly compression resistant building material, without cavities or low hole surface percentage (up to a max. 15 % e. g. as grip holes). This type is very well suited for anchor fixings.
- 2 Solid bricks with porous structure usually have a very large number of pores and low compressive strength. Therefore, special fixings should be used, e. g. fixings with a longer expansion zone or bonded anchors.
- 3 Perforated bricks with a compact structure (perforated and hollow bricks) are mostly manufactured from the same compressive strength materials as solid blocks but with cavities. If higher loads are introduced into these building materials, special fixings should be used (e. g. bonded anchors, FIS V), which bridge or fill the cavities.
- 4 Perforated bricks with porous structure have many cavities and pores and thus generally a low compressive strength. In this case, special care is required when selecting the fixing. Suitable fixings include those with a long expansion zone or form locking injection anchors.



Lightweight concrete solid block

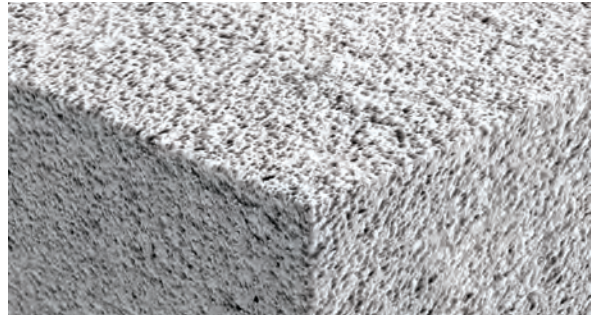

Aerated concrete



Lightweight concrete hollow block

Expert tip

- Before fixing in masonry, determine which brick type (designation, size, compressive strength) and mortar type (mortar category) has been used.
- For safety anchoring in unknown or old masonry, pull out tests must be carried out on-site to determine the anchor load bearing capacity.
- For fixings close to the edge, it is important to know if the wall is a load bearing wall as this prevents the risk of brick pull out.
- Even solid brick can have holes (e. g. MZ, KS). The holes are mostly larger grip-holes in the centre of the brick (up to max. 15 % cavity proportion per brick).
- Always drill without hammer function in perforated and hollow bricks. Here, special, sharply ground drills with hard metal tips are suitable.
- Plaster or other non load-bearing layers may not be added to the load-bearing base and are not to be used in calculating the anchorage depth.
- Avoid anchoring into masonry joints as much as possible due to joint inhomogeneity. If anchoring into a joint cannot be avoided (e. g. plaster on masonry) loads should be reduced.
- For systems approved by building authorities, anchoring in joints (vertical or horizontal joints) is regulated in the approval notices.
- For anchoring high loads in perforated bricks, the anchorage depth should be increased.
- Expansion fixings (e. g. FAZ II or FBN II) are not suitable for use in masonry due to its high expansion forces which may lead to cracks in the brick. Frame fixings are suitable due to its longer expansion part.
- Bonded anchors achieve the highest possible loads in masonry

Building material – Drywall panels.



Laminated wood panel

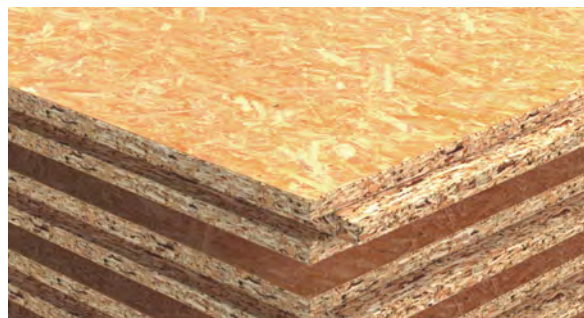

OSB boards

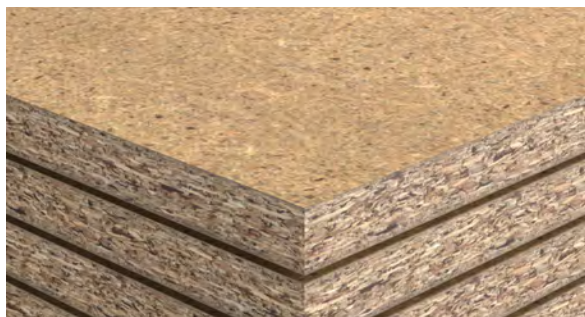

Chipboard

Panel building materials are thin-walled materials that often have limited strength – e. g. plasterboard like “Rigips”, “Knauf”, “LaGyp”, “Norgips”; Gypsum fibreboard like “Fermacell”, “Rigicell” or chip board, hard fibre boards, plywood and others.

The main characteristics of panel building materials are:

- Often thin-walled materials, mainly with limited strength.
- Easy-to-process materials for non load-bearing walls and also used as cladding material (e. g. walls, roofs or ceilings).
- A wide range of different building materials.

Special fixing elements must be used:

- **Cavity fixings** are fixings made of plastic or metal, which anchor by form locking into the material, e. g. by knotting or a snap on mechanism (e. g. toggles).

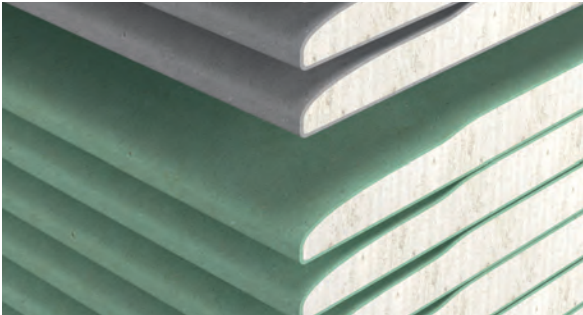

Plasterboard

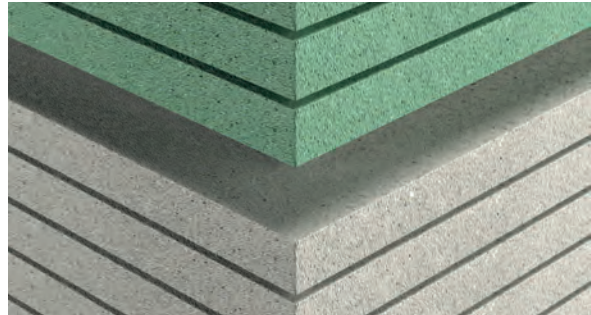

Gypsum fibre reinforced

Expert tip

- Only approved anchors should be used for **lightweight materials, prestressed hollow core** slabs and panel materials.
- Contact your fischer consultant on site before anchoring **heavy or safety-relevant loads** in the above-mentioned substrates

Drilling.

The building material determines the drilling method.
Five methods are possible:



Rotary drilling

Rotary drilling without impact, uses a sharply ground carbide drill bit. When this method is used, the drill hole does not become too large and the perforated brick's webs do not break.



Impact drilling (mechanical)

Impact drill with rotation and a high number of light strokes, is suitable for dense structured building materials..



Hammer drilling (pneumatic)

Hammer drill uses rotation and a low number of light strokes with high impact energy, also suitable for dense structured solid building materials.



Diamond or core drilling process

Mainly used for larger drill hole diameters or for heavily reinforced components and/or if noise or vibration must be reduced.

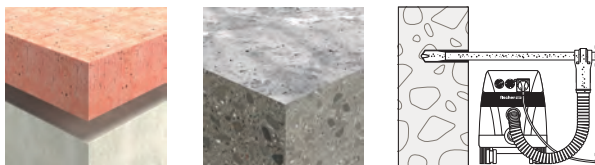

Hollow drilling

Special drill with a hollow core, which is connected to a vacuum cleaner. Cleans the drilled hole during the drilling operation. No further brushing or blowing is required. Can be used in concrete and masonry with dense structure.

Expert tip

- The drilling method for approved anchors is specified in the **approval / assessment**.
- Drill bits with **excessively worn cutting edges** should **not be used** (see approval/assessment).
- For certain fixings, **special drills** are required (e. g. a stop drill) as per approval/assessment.
- **Drill holes** must be **carefully cleaned** (blown out and brushed). See the respective approval/assessment or manufacturer's specifications.
- The **drill hole depth** is always exactly specified and relates to a given anchoring base thickness. For general applications without an approval/assessment the following applies: the drill hole depth + 30 mm should not exceed the anchoring base thickness.
- In case of **incorrect drilled** holes (hitting reinforcements or wrong location), the location for the new drill hole depends on the applicable fixing). Usually, the distance for the new drill hole must be twice the depth of the incorrect drill hole. The wrong drill hole must be filled with injection mortar (e. g. FIS V).
- **Diamond core drilling** is only permitted if stated in the approval/assessment or according to manufacturer's guidelines (e. g. RSB, FIS EM Plus, FAZ II, FBS II...).
- **The load bearing capacity is reduced** by water filled holes or wet substrates especially for chemical or plastic fixings.
- **Cutting** through a reinforcement must be avoided.
- **The drill hole** must be drilled perpendicular to the anchor base (an inclination of up to 5° is permitted). Exceptional cases are regulated in the anchor approval/assessment and or according to manufacturer's guidelines.

Installation.

In general, the following aspects must be taken into consideration during installation.

The edge distance c and centre distance s , as well as the component thickness and width, must be carefully observed to ensure that the fixing can take the required load. Otherwise, it may lead to spalling of the construction material or cracks. For fixings without approval, e.g. nylon fixings, a minimum edge distance of $c = 1 \times h_{ef}$ (h_{ef} = anchorage depth) and a minimum spacing of $s = 1 \times h_{ef}$ must be adhered to for concrete. When using non approved metal anchors, a minimum edge distance of $c = 1.5 \times h_{ef}$ and a minimum spacing of $s = 3 \times h_{ef}$ is recommended. When using hammer-set anchors, spacing and edge distance can increase due to higher expansion forces.

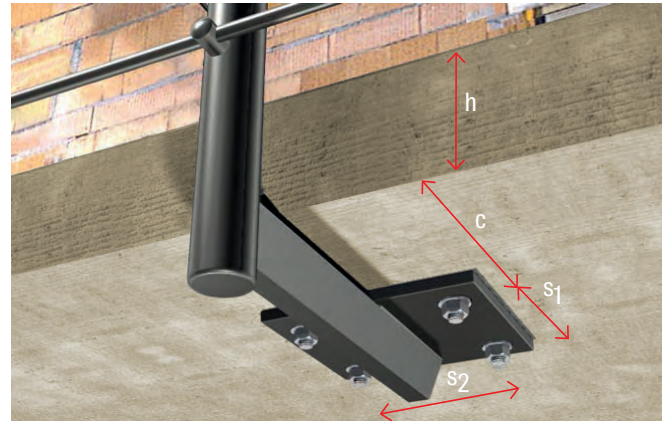

The drill hole depth h_b must be larger than the anchorage depth (exception chemical anchor systems), to ensure that the screw has enough room at the end of the fixing element to penetrate at least one time the screw's diameter.

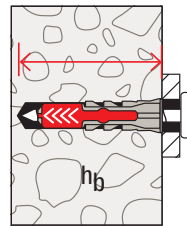

Drill hole cleaning after drilling, e.g. by blowing out, brushing or suction, is generally necessary. The load bearing capacity will be reduced, if the hole is not cleaned. Exceptions: approved anchor systems where no hole cleaning is required, e.g. FHB II + PF - High speed capsule.

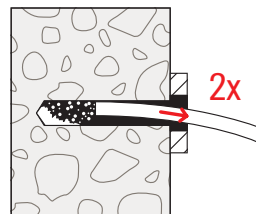
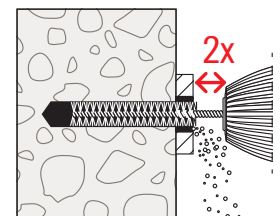
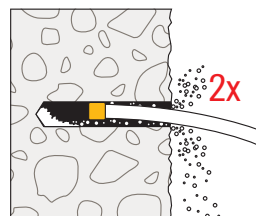

Expert tip

- **Strictly adhere to specifications** for component geometry, edges and spacings distances. If this is not taken into account, the component will be damaged or the anchor capacity will be reduced.
- **Drill hole cleaning is essential.** The specifications in the approvals and the manufacturer's specifications must be observed.

Installation types.

There are three different types of installation.

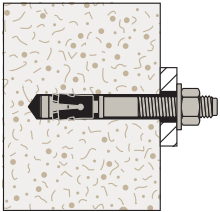

Anchor bolt FAZ II

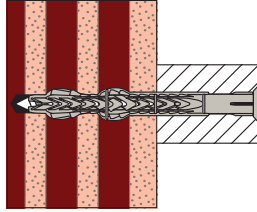

Frame fixing SXRL

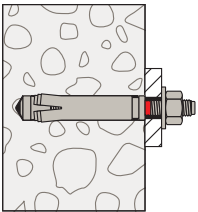

Zykon anchor FZA

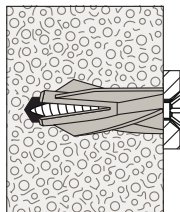

Aircrete anchor GB

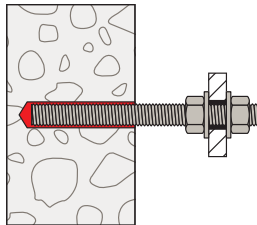

Threaded rod FIS A

Push-through installation

In particular for simplifying installation for series installations or for attachments with two or more fixing points:

- If the attachment's hole diameter is larger than the drill bit diameter, then the attachment can be used as a template. Please note: The drill bit tip is generally larger than the nominal diameter of the drill.
- In addition to facilitating a simple installation, an exact fit is also achieved.
- The fixing is inserted into the drill hole through the attachment and then tightened (e.g. FAZ II, FBN II, FH II).

Pre-positioned installation

The anchor is installed before fastening the attachment. If drilling is not done precisely, then the holes in the attachment will not match up. This could mean that the anchors cannot be installed or could cause damage to the anchors. The installation sequence:

- Transfer the hole pattern of the fixture to the anchor base.
- Drill and clean the holes, install the attachment and then fix the attachment (e.g. plastic fixings: S, SX, UX; metal fixings: FZA, EA II).

Stand-off installation

This allows attachments to be compression and tension resistant at a certain distance from the anchor base. For this purpose, external threaded metal anchors (e.g. FAZ II, FBN II) or internal threaded anchors (e.g. EA II) with screws or threaded rods are clamped against the anchor base surface while using a bearing washer and nut. When using chemical systems with threaded rods (e.g. FIS SB, FIS V, FIS V Plus, FIS EM Plus, and FIS A), the installation can be done without using a bearing washer and nut. A stand-off installation is absolutely not recommended in seismic regions.

Expert tip

- **Clearance holes in the attachment** are specified for the respective anchor size in the approvals/assessments and manufacturer's guidelines.
- **For stand - off installations** with shear loads on the anchor, additional bending moment occurs and this must be considered.
- **The attachment must lie** fully flush on the surface base or it must have either a compression resistant levelling layer of max. 3 mm or half the anchor's diameter, otherwise the anchor must be checked for bending.
- **The attachment shall be in contact with the anchor** over its entire thickness, otherwise the anchor must be checked for bending.
- **Usable length is the maximum fixing height** t_{fix} which takes into account the attachment's thickness plus additional non-bearing layers (e.g. plaster, air, insulation etc.).
- Post-installed anchors must be tightened with a specific torque. A calibrated torque wrench must be used to ensure the correct pre-stressing force and the correct installation of the anchor. **For chemical anchors, the prescribed hardening time must be adhered** to before tightening torque or service load can be applied.
- Anchors must be mounted as a standard unit as delivered. The exchange or removal of parts is not permitted.

Loads.

When selecting an anchor, it is necessary to know the load on the total construction and the resulting action forces.

Action forces can differ based on:

Dimension · Direction · Type of load · Point of application

- There are various types of loads: Approvals generally give characteristic resistance. In the manufacturer's guidelines, "permissible loads" are specified for products with approvals. For anchors without an approval, "recommended loads" are given by the manufacturer.
- Determine the size, direction and point of application** of the load. These parameters determine which anchor should be used.
- Characteristic resistance** (N_{RK} or V_{RK}) describes the 5% fractile of resistance. (Value with a 95% probability of being exceeded, with a confidence level of 90%).
- Permissible loads** are working loads that already include an appropriate safety factor. These only apply if the approval conditions are complied with (N_{perm} or V_{perm}).
- Recommended loads or maximum working loads** include an adequate safety factor. These only apply if the manufacturer's specifications are complied with (F_{REC} – valid for all load directions, N_{REC} – for compressive or tensile load or V_{REC} for shear load).
- The calculation** is carried out by dividing the respective failure load or characteristic loads by a safety factor.
- Recommended safety factors compared to the average failure load:**
 - Steel and bonded anchors $\gamma \geq 4$
 - Plastic anchors $\gamma \geq 7$
 - Hammerfix anchors N $\gamma \geq 4$
- Recommended safety factors compared to the characteristic failure loads:**
 - Steel and bonded anchors $\gamma \geq 3$
 - Plastic anchors $\gamma \geq 5$

For deviations to the regulation, see load tables. For certain products, the safety factors may deviate. In general, the global safety factor is calculated using the scatter of the failure load, the failure probability and the reliability index of a product.
- The specified loads** apply to individual anchors that are installed away from the edge, i. e. there is no influence from edges or other anchors.
- The characteristic spacing and edge distances**, marked with $c_{Cr,N}$ and $c_{Cr,V}$, give the distances at which an anchor achieves its max. characteristic load.
- The specified minimum spacing and edge distance**, marked with s_{min} and c_{min} , indicates the distance at which no failure of the building material will occur when installing the anchor (cracks). These distances are mandatory and must be complied with. The characteristic spacing and edge distances may be shorter but not less than the minimum values but at the same time the load bearing capacity must

Load directions

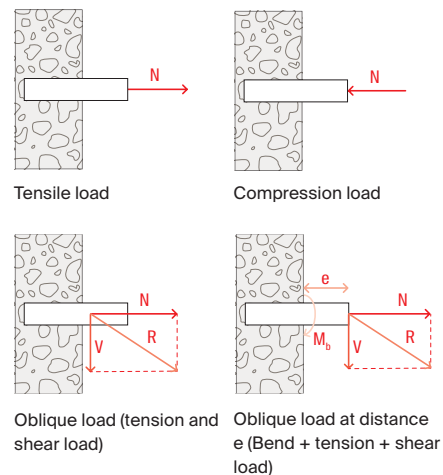

Types of loads

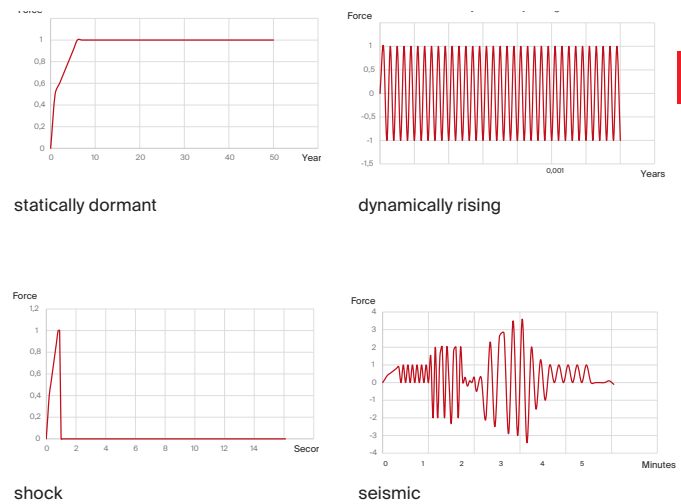

be reduced. When combined loads occur, loads are determined separately for tensile and shear load and the overall utilization is determined by means of an interaction equation. As a rule, the sum of the ratio values of the applied load divided by the resistance from tensile and shear loads is less than or equal to one point two.

Working principles.

There are different load transfer mechanisms which induce forces acting on the anchor in a building material.

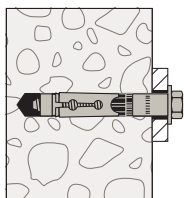

Sleeve anchor (e.g. FH II)

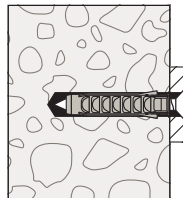

Nylon anchor (e.g. SX)

For **frictional locking**, the expanding part of the anchor is pressed against the drill hole wall.

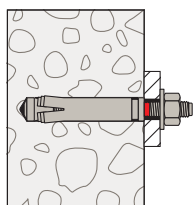

Undercut anchor (e.g. FZA)

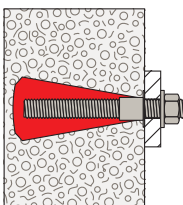

Injection anchor (e.g. FIS V with cone drill PBB)

For **form locking**, the anchor geometry adapts to the substrate's form or drill hole shape (e.g. conical drill hole).

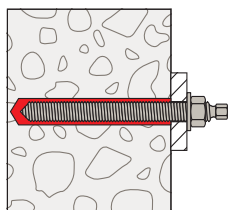

Resin anchor (e.g. Superbond RSB)

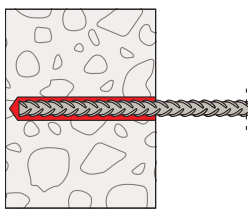

Subsequent reinforcement connector with concrete reinforcing bars (e.g. FIS EM Plus)

For **adhesive bonding**, the load will be transferred by a combination of adhesion and micro-keying (e.g. using resin / injection mortar).

Expert tip

- For many fixings, a combination of working principles occurs (e.g. in soft base material a combination of friction and form locking takes place).

Failure modes.

If there is excessive stress, incorrect installation or a substrate with inadequate load bearing capacity, the following types of failure can occur.

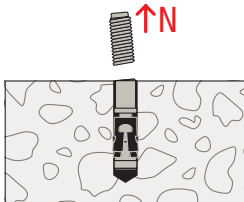

Steel failure tension

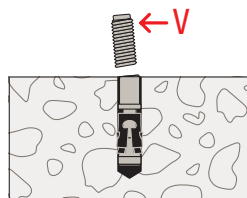

Steel failure shear

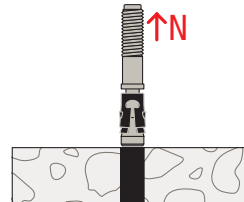

Pull out

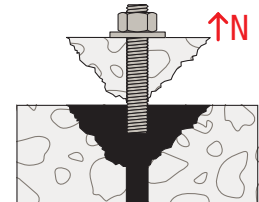

Combined failure

Steel failure:

- Insufficient steel strength for the applied load

Pull out failure:

- Friction failure and or adhesion failure due to high load or incorrect installation

Combined failure:

- Pull out
- Concrete failure near the surface

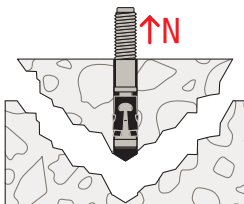

Concrete cone failure

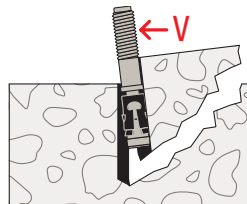

Pry-out failure



Concrete splitting failure

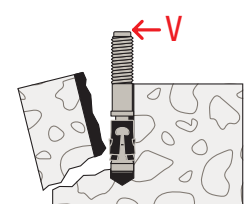

Concrete edge failure

Anchor base failure:

- Tensile load "N" or shear load "V" too high
- Inadequate strength of anchor base
- Insufficient embedment depth

Anchor base splitting:

- Insufficient component dimensions
- Deviation from the spacing and edge distances
- Excessive expansion pressure

Expert tip

- In most anchor approvals/assessments, the anchoring of **predominately static loads** is regulated. However, there are also approvals which regulate non-static loads (fatigue loads, e.g. FHB dyn).
- Seismic loads for post-installed anchors are regulated in Europe according to the Eurocode 1992-4 and the testing of the product for the seismic services is carried out with a European Technical Assessment ETA. The seismic performance of an anchor system is described according to performance categories in C1 and C2. In the American methods according to

ACI-318-14 these categories do not exist for the seismic case, the testing of the product is always carried out according to an ICC-ESR in concrete for the earthquake case without dividing the product into categories. Classification in accordance with C1 and C2 is not necessary). The performance category and the characteristic values are found in the respective ETA (e.g. FAZ II, FH II, FIS SB, FIS EM Plus...).

- **The main causes for anchor failure are overloading, incorrect installation or an insufficient load bearing anchoring base.**

Cracks in concrete components.

Cracks can occur anywhere in concrete at any time:

Factors involved in this are loads such as dead loads, traffic or wind loads, concrete shrinkage and creeping or external influences such as seismic activity or ground motion result in stresses and deformations thus leading to cracks.

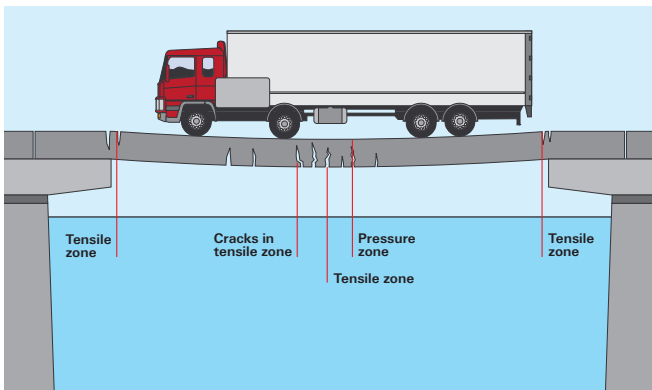

Example

If a bridge designed as a single-span element is loaded, the bridge will buckle. Due to this buckling, cracks could occur in the element's tensile area.

Concrete is not able to support tensile loads, therefore, reinforcements are placed in the element to take the tensile load area numerous cracks are formed that are barely visible to the naked eye. This is called the cracked tensile zone.

16

Suitable anchor systems for cracked concrete

When fixing in concrete, **cracks** are always **expected in the anchoring area which will have an impact on the load bearing capacity** of the anchor system. However, it is very complicated, if not impossible, to prove whether the concrete is cracked or not cracked.

For safety reasons, designers and craftsmen should **always use anchor bolts which are suitable for cracked concrete**. Fixings with an approval/assessment according to EN 1992-4 for cracked concrete have proven their suitability in cracks, therefore they can be used without any restrictions in tensile and compression zones of a concrete member.

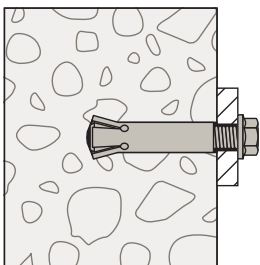

Undercut anchor FZA

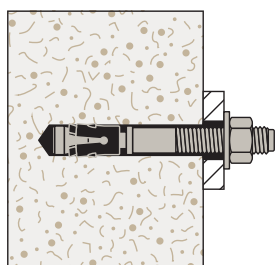

Bolt anchor FAZ II

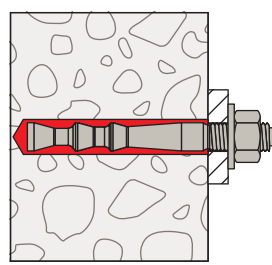

Threaded rod FHB II

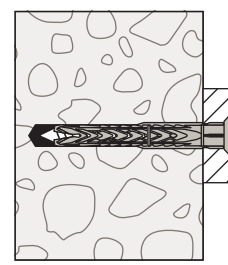

Frame fixing SXRL

Due to safety reasons, always use crack-suitable anchor systems such as FAZ II, FH II, FHB II, FIS SB, FIS EM Plus, FIS V or FIS V Plus.

Fire protection – Fundamentals.

General requirements of building structures for fire protection.

Structural installations

They are to be ordered, erected, changed and brought into commission in such a way that:

- The emergence of a fire is prevented from breaking out.
- The spread of fire and smoke (spread of fire) is prevented.
- In the event of a fire, the rescue of people and animals is possible.
- Effective fire-fighting operations are possible.

German regulation

In Germany, the procedure for construction and operational fire protection are specified by the fire protection standard DIN 4102, the Model Building Ordinance (MBO), Regional Construction Ordinances (LBO) and various trade-specific regulations from professional associations.

The following applies as per Section 1 and 2 of DIN 4102:

Building materials such as **concrete, wood, stone, metal** etc., are classified according to their behaviour **into flammable or non-flammable building material classes.**

However, **components composed of different flammable and non-flammable materials** are not classified into fire classes in building construction but they are evaluated as a complete system according to their fire resistance duration. The fire resistance duration R is indicated in minutes and classified according to two categories:

- **Components with a fire resistance duration of R30 and R60 are fire-inhibiting.**
- **Fire-resistant**, are all components with a fire resistance duration of R90, R120 and R180.

Tested systems such as cable, ventilation or duct systems are not only tested for fire resistance, but also for functional capability in the event of fire (e. g. supply lines to sprinkler systems). The fire resistance duration of these systems is e. g. E30 to E120 for electrical cable systems or L30 to L120 for specified ventilation ducts. The anchors that are used to fasten these systems must have at least the same fire resistance duration.

European standardisation

In accordance with the European Norm DIN EN 13501-1, the classification of fire behaviour of building materials / products is similar to that of DIN 4102. The classifications are, however, much more precise.

In addition to, the main classification criteria concerning flammability, flame spread and heat released, e. g. smoke development and dropping behaviour is tested.

Fire resistance of components has been tested in Germany in accordance with the European Norm DIN EN 1363 or DIN EN 1365 since 2000. The fire resistance duration is then labelled with the letter R for "Resistance".

The standard temperature-time curve (ETK) of DIN 4102 and ISO 834 is based on a simulation of real fire conditions and forms the evaluation basis that is used worldwide to determine the fire resistance duration. In addition, there are other temperature curves for special fire exposures, e. g. the hydrocarbon curve for destructive fires caused by flammable liquids or the RAB/ZTV tunnel curve (Germany) or the Rijkswaterstaat tunnel curve (the Netherlands), which describe tunnel fires.

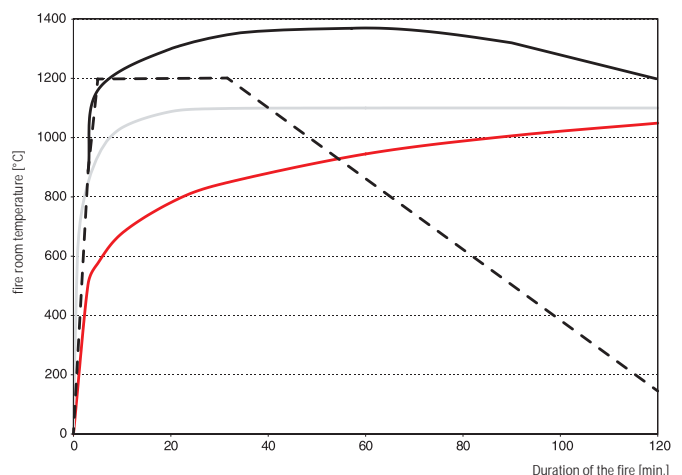

Temperature curves: — (ETK), — Hydrocarbon curve, -- RABT/ZTV tunnel curve — Rijkswaterstaat tunnel curve

Fire protection in fastening technology.

The fastening technology has a vital importance in fire protection. To ensure the functional capability and stability of railings, pipe systems, fire safety doors or ceiling elements.

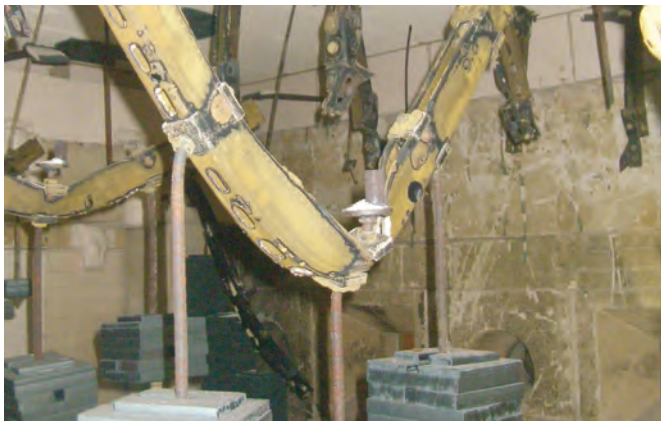

Before the fire test

Assessing fixings for fire is carried out in accordance with the technical regulation EOTA TR020 or in accordance with fire protection reports.

The labelling and classification of anchors and fixings is classified in:

- 1 Fire behaviour (e. g. non-flammable)
- 2 Fire resistance duration (e. g. R90)

For this purpose, the legal regulations set down in the final draft of the Delegated Act "Fire Behaviour" must be observed.

EOTA TR020 only states anchor performance ratings that have an **ETA for cracked concrete!** Meanwhile, a new evaluation document issued by the German Institute for Construction Engineering (DIBt) is used to determine the characteristic load values and the corresponding fire resistance duration. A partial safety factor of $\gamma_M = 1.0$ on the load side is used in the event of fire.

The fire values only refer to anchor bolts that are directly exposed to flames.

Alternatively, anchors can be protected from direct exposure to fire by using fire protection panels or fire protecting coatings.

For fixing cladding systems, it is assumed that the load bearing capacity of specified plastic screw anchors in concrete with an external diameter of 10 mm and a metal screw diameter of 7 mm and an anchoring depth of $h_{ef} = 50$ mm with a polyamide PA6 plastic sleeve has a sufficient fire resistance of at least 90 minutes (R90), if the permissible load (no permanent centric tensile load) is ≤ 0.8 kN.



During the fire test



After the fire test

Corrosion – Fundamentals.

Corrosion is a chemical reaction which degrades metal.

The less noble the metal (“electrochemical potential”), the more severe the material damage is, resulting in metal loss or corrosion flakes. For this reason, different appearance patterns have been determined. **The most common types of corrosion in fixings and anchors are:**

Surface corrosion: In this case, the metal corrodes relatively uniformly over the entire surface or over a part of the surface. An example of this is the invisible rusting of a screw in the transition area from anchor plate to hole due to condensation. The result: A connection that appears completely intact from the outside, but suddenly fails.

Contact corrosion: If metals with a different nobility are in contact with each other in a conductive medium, the less noble metal always corrodes (the anode). Whereas stainless is not affected. A decisive factor is the surface ratios of the two types of metal: The greater the surface area of the most noble metal in comparison with the less noble, the greater the corrosion. For example, if larger stainless steel sheets are screwed with galvanised screws, the screws will be aggressively attacked within a very short time. Whereas using stainless screws in galvanised sheets poses no problems.

Stress corrosion cracking: Permanent internal or external tensile stresses lead to metal strain or corrosion. In this process, a crack develops due to mechanical stresses, which grows under increasing loads and thus creates a path for progressive corrosion. For example, this occurs with stainless steel of corrosion resistance Class III e.g. R-Steel, in an atmosphere containing chlorine (swimming pools). Generally, stress corrosion cracking is not visible with fixings and usually leads to sudden failure of the anchoring.



In 1985, the suspended concrete ceiling of an indoor swimming pool collapsed in Uster, Switzerland. The stainless steel ceiling attachments exhibited no external defects, but were completely destroyed internally in some cases due to stress corrosion cracking.

Corrosion protection.

There are different ways to protect fastenings from corrosion. The most important are:

Galvanised zinc coating (or also electrolytic zinc coating) followed by passivation is the most common corrosion protection used in metal finishing. A zinc coating thickness of 3–10 µm offers excellent corrosion protection for damp rooms and outdoor use.

Hot-dip galvanising is the application of a metal zinc coating by dipping it in molten zinc (at approx. 450 °C). Zinc layer thickness's of 45–80 µm offer an excellent corrosion protection for moist rooms and outdoor use.

Stainless steel fixings of corrosion resistance class III e.g. R, material no. 1.4401, 1.4404 and 1.4571 as well as two phased duplex steel (austenitic and ferritic structure / magnetic) are suitable for anchoring in damp rooms, in open air, in industrial atmospheres or near the sea (but not directly in sea water).

Stainless steel anchors made from high corrosion-resistant steel of the corrosion resistance class V e.g. HCR material no. 1.4529 are used in especially aggressive environments e.g. in atmospheres containing chlorine (swimming pools), in road tunnels or with direct sea water contact. Due to their high molybdenum content they are resistant in such aggressive environments. That means that steel type 1.4529 – containing chrome, molybdenum and nickel – has an alloy content of 58%. The rest consists of iron and carbon. Due to this very high alloy content, the production for this steel type is very expensive, but on the other hand the connection is safe and maintenance-free in terms of corrosion.

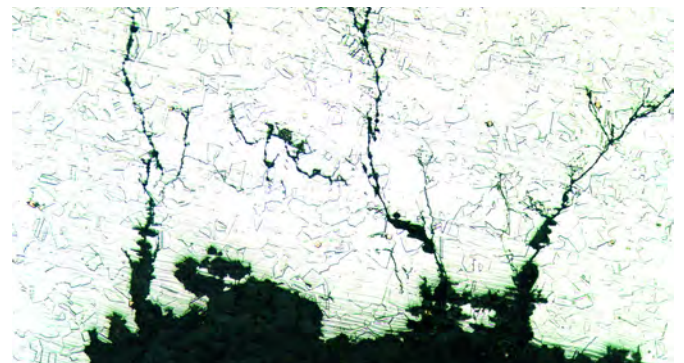

Example of trans-crystalline stress corrosion cracking on stainless steel 1.4401 with high chloride concentration

Dynamics.

For predominantly non-static loads.



Elevator guide rails

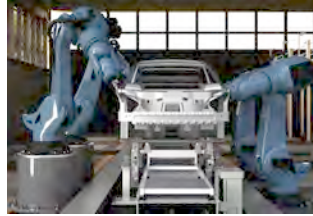

Industrial robots

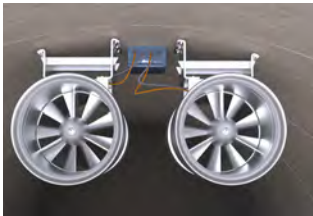

Blast fans



Antenna and masts

The general building approvals issued by the **German Institute of Construction Engineering (DiBt) and the European Technical Approvals / Assessments (ETA)** are mainly valid for predominately static loads. However, there are certain applications e.g. swing-ing cranes, crane rails, jib cranes, elevator guide rails, machines, industrial robots and blast fans in tunnels including antenna and masts which are subjected to dynamic effects.

In general, the anchoring of components with more than > 1000 load cycles must be carried out using fastening elements that have been checked and approved for this purpose. Until recently, the design for post-installed anchors for such dynamically loaded applications was nearly impossible. Time consuming and costly expert reports and or approvals for individual applications were required.

The bonded anchors: fischer Highbond anchor FHB dyn and fischer UMV multicone dyn and FDA **have a German DiBt approval for dynamic loads.** In the approval, only fatigue loads are considered as dynamic loads and not loads from shock or seismic activity.

The approvals apply to the anchoring of dynamic loads with unlimited numbers of load cycles, for tension and for shear loads.

In addition, the FHB dyn is manufactured in anchor size M12 and M16 from highly corrosion-resistant steel (e.g. corrosion resistant Class V - 1.4529).

Dynamic load tests have shown - compared to normal stainless steel grades of corrosion resistant class III (e.g. 1.4401 also known as 316) - that this material is not only highly suitable for indoor and outdoor humid environments, as well as other aggressive conditions, it is also highly suitable for dynamic loadings.

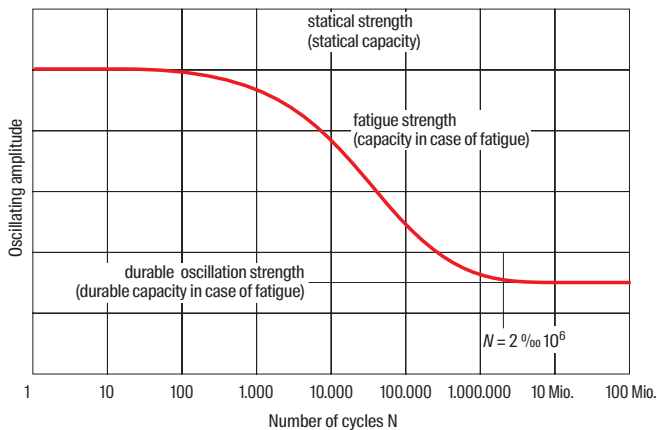

Wöhler curve

Action	Run of the oscillation	Possible cause
harmonic	 sinusoidal	Unbalances, tumbling machines
periodic	 optional, periodical	Regularly abutting parts (e.g. punching machines), rail- and road traffic
transient	 optional, nonperiodical	Earthquakes
impulsive	 optional, with very short time of influence	Impact, explosion

Legal basis.

The European Union (EU) determines the legal foundation for the assessment, CE labelling and bringing building products into the European Economic Area (EEA).

The aim is to reduce trade barriers by harmonising the requirements of building products.

REGULATION (EU) No 305/2011 (Construction Products Regulations) OF THE EUROPEAN PARLIAMENT AND COUNCIL fully came into force on 1st July 2013. The Construction Products Regulation is law in all EU countries. However, the Construction Product Directive 89/106 / EEC is not law in all EU countries.

Important building requirements include:

1. Mechanical strength and stability
2. Fire protection
3. Hygiene, health and environmental protection
4. Safety and accessibility during use
5. Sound protection
6. Energy saving and heat protection
7. Sustainable use of natural resources

When a construction product is covered by a harmonised standard (hEN), or a European Technical Assessment or Approval (ETA) has been issued for this product, the manufacturer is obligated to draw up a Declaration of Performance (DoP) for this product and affix the CE marking on the product. The application for an ETA for a construction product by the manufacturer is voluntary. National approvals may only be issued if a construction product is not marked with a CE label.

Existing European Technical Approvals (ETA) are valid until the end of the validity date and will be amended with the Declaration of Performance (DoP) by the manufacturer from the due date.

The reference number of the DoP is part of the CE marking and must be determined by the manufacturer. The Declarations of Performance (DoP) are available on the fischer website under "Approvals/Assessments": <http://www.fischer.de/sdb>.

Construction products are products, or parts which are permanently incorporated into buildings. Their performance influences the structure's basic requirements (e. g. mechanical strength). Therefore, construction products and materials for safety relevant applications are affected.

The CE mark is the only means to certify whether the manufacturer has conformed to the applicable harmonised requirements of construction products. The CE label allows the construction product to be freely traded without trade barriers in the European Economic Area.

Each Member State determines the essential characteristics for use of the construction product and its performance in its territory. The unrestricted use of a construction product in a Member State depends on whether performance values exist in the DoP for the essential characteristics determined by the Member State. If one characteristic is declared with "NPD" (No Performance Determined), this can lead to a ban on use in a Member State. Therefore, each member State must establish Product Contact Points, which will provide information on these regulations. In Germany, this is the Federal Institute for Material Research and Testing (BAM: see www.pcp.bam.de).

Assessment procedure.

Fasteners which are not covered by a harmonised standard (hEN) can apply for an ETA (European Technical Assessment) on the basis of a European Assessment Document (EAD).

Existing assessment documents, such as ETAGs (European Technical Approval Guidelines) for metal and plastic fixings are still valid and transferred into EADs in accordance with the EU Construction Products Regulation (CRP). The ETAGs and the new EADs can be downloaded from the EOTA website: <http://www.eota.eu>

The assessment document for mechanical fasteners (ETAG 001-1, -2, -3, -4 or in the future, EAD 33-0232) and the assessment document for bonded anchors (ETAG 001-5 or in the future, EAD 33-0499) divides possible approvals of metal fixings into 12 options.

Options 1-6 are for use in cracked and non-cracked concrete, options 7-12 are only for use in non-cracked concrete. Anchors of Option 1 offer the largest range of flexibility for assessment, since performance values for concrete of the strength classes C20/25 to C50/60, as well as the minimum spacing and edge distances are available (see table below).

Section 6 of the ETAG 001 (in the future, EAD 33-0747) regulates the assessment of metal fixings in cracked and non-cracked concrete for multiple use for non-structural systems. Non-load bearing systems include components which do not contribute to the stability of the construction, they only transmit their dead or wind load. These are, for instance, simple suspended ceilings and false ceilings, pipelines and façade claddings.

When using fixings for multiple use, it is assumed that if excessive slippage or failure of a fixing point occurs, that the load will be transferred to neighbouring fixing point. A fixing point can be defined as a single anchor or a group of anchors.

This is known as a redundant system, where stability is not affected by an individual anchor failure.

Possible assessment options according to EAD

Options	Cracked concrete	Non-cracked concrete	One value for all concrete strengths	Different values for C20/25 to C50/60	One value for load direction	Separate values for tensile and shear capacity	C_{Cr}/S_{Cr}	$C_{min} < C_{Cr}/S_{min} < S_{Cr}$	Design method as per EN 1992-4
1	●	–	–	●	–	●	●	●	A
2	●	–	●	–	–	●	●	●	A
3	●	–	–	●	●	–	●	●	B
4	●	–	●	–	●	–	●	●	B
5	●	–	–	●	●	–	●	–	C
6	●	–	●	–	●	–	●	–	C
7	–	●	–	●	–	●	●	●	A
8	–	●	●	–	–	●	●	●	A
9	–	●	–	●	●	–	●	●	B
10	–	●	●	–	●	–	●	●	B
11	–	●	–	●	●	–	●	–	C
12	–	●	●	–	●	–	●	–	C

Design of fastenings.

Two different anchor designs are differentiated.

Method with global safety factors

Permissible loads are determined from the average failure load or from the 5% fractile load and compared with the action load.

The safety factor depends on the anchoring system, the type of installation and external influences such as temperature and or humidity. Global safety factors are generally $\gamma = 3$ for steel and bonded anchors and $\gamma = 5$ for plastic anchors.

Methods with partial safety factors

According to this method, it is shown that the value of the design actions S_d does not exceed the value of the design resistance R_d ($S_d \leq R_d$).

The action on fixings are determined according to the same rules and used the same partial safety factors employed in reinforced concrete design (see Eurocode 1990; national appendix must be observed).

The design resistance is determined by using the characteristic resistance and the partial safety factor of the material (γ_M), which takes into account the scatter of the material. The values can be taken directly from the ETA. Safety is national law. The design method as well as the related partial safety factors are determined by the Member State.

Only the product-specific coefficient for installation is specified in the ETA, which is used to calculate the partial factor γ_M . The design standard EN 1992-4, contains the national determined partial safety factors (observe the respective national appendix).

The design method as set down according to ETAG 001, Annex C - design method for metal anchors and the design method according to TR029 - bonded anchor design in concrete, as well as CEN/TS 1992-4, Section 4 (mechanical anchors) and Section 5 (chemical anchors) are the current methods for anchor design based on a European Technical Approval or Assessment (ETA). Moreover, the ETAG 001 Annex C distinguishes between three different design methods (A, B and C), method A being the most important and the most economical method since anchors are considered separately for all load directions and failure modes. Methods B and C play a minor role and are hardly used.

Other important design provisions are:

EOTA TR020

Anchor design in concrete under fire exposure, or CEN/TS 1992-4, Part 1, Appendix D

EOTA TR045

Anchor design in concrete for seismic actions

The applicable assessment design methods are generally indicated in the respective ETA. It is important that design methods are not commingled.

The design for metal anchor (under static and seismic loads as well as under fire exposure) is summarised in EN1992-4, i.e. in Section 4 of the Eurocode 2, ratified by each Member State and, adapted for national annexes.

fischer has developed a simple yet powerful design software for daily use: the fischer Fixperience-Module C-FIX. The software enables designers and users to carry out anchor designs according to different design methods. Complex anchor arrangements can be calculated quickly and easily. The feature "multiple design" makes it possible to select the best technical and cost saving solution.

The CE mark is the only means to certify whether the manufacturer has conformed to the applicable harmonised requirements of construction products. The CE label allows the construction product to be freely traded without trade barriers in the European Economic Area.

Each Member State determines the essential characteristics for use of the construction product and its performance in its territory. The unrestricted use of a construction product in a Member State depends on whether performance values exist in the DoP for the essential characteristics determined by the Member State. If one characteristic is declared with "NPD" (No Performance Determined), this can lead to a ban on use in a Member State. Therefore, each member State must establish Product Contact Points, which will provide information on these regulations. In Germany, this is the Federal Institute for Material Research and Testing (BAM: see www.pcp.bam.de).

Approvals, markings and their importance.

In the following, excerpts of approvals that are currently issued in Europe and their symbols will be given with their corresponding importance. Please check whether your application is safety relevant.

An application is safety relevant when failure of anchorages would cause risk to human life or serious injuries and/or lead to considerable economic consequences. In this case please use anchors with a European Technical (ETA) or with a German Approval. You may recognise these anchors by:



ETA-05/0069, for cracked concrete

European Technical Approval/Assessment

Issued by a European approval authority (e.g. DIBt) on the basis of the guidelines for European technical approvals (ETAG). ETA (English): European Technical Approval/Assessment. CE: The CE marks the conformity of the product to all applicable legal provisions in which their installation is intended. This means that the CE mark only certifies that the requirements determined in the relevant harmonisation legal provisions of the union have been complied with. Products with the CE mark can be freely traded in the European Economic Market.



ICC ESR-2948

ICC = International Code Council, formed from BOCA, ICBO & SBCCI:

ICC Evaluation Service Inc. (ICC ES) issues reports, e.g. for subsequent anchoring on the basis of the International Building Code® and the related standards in the United States of America.



from M10

FM Certificate:

Recognised for use in local water-based fire extinguisher systems (Factory Mutual Research Corporation for Property Conservation, American insurance company).



General Building Authority Approval:

German approval, issued by the DIBt, Berlin with the accompanying certificate of conformity for construction products with the general building authority approval. Confirmed by a material testing institute.



Fire resistance classification R120

Fire-tested fixing:

German approval, issued by the DIBt, Berlin with the accompanying certificate of conformity for construction products with the general building authority approval. Confirmed by a material testing institute.



INOX STAINLESS STEEL

Product is available in highly corrosion resistant steel of corrosion resistance class IV, e.g. 1.4529.

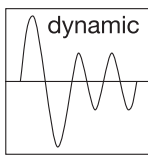

Dynamically loadable anchors

The anchor is suitable and approved for anchoring of “not predominantly static” (i.e. dynamic) loads. static” (i.e. dynamic) loads. static” (i.e. dynamic) loads.



General construction-related test certificate



The fixing is suitable for anchoring under **seismic influence**.

Please note: The ICC-ESRs also allow seismic stress (see Category C1 and C2 in accordance with the ETAG 001 Annex E).

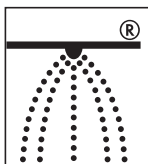

Mark for labels that confirm compliance with the VDS-CEA guidelines for sprinkler systems, planning and installation. Fixings labelled as such may be used for fixing pipes for extinguishing systems.



Tested for flammability in accordance with VDE.

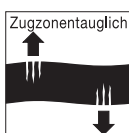

Fixings for tensile zones

The fixing is suitable and approved for anchoring in cracked concrete (tensile zone) and in uncracked concrete (compression zone).



Fixing made of high-quality, ageing-resistant **nylon** (polyamide).



Component test with window frame screws in accordance with ift guideline MO-01/1; Testing structural connections on windows.

The term “approvals” used in the catalogue consists of documents that are available and can be used as evidence of the usability of building products for which the documents were issued. These are (fire) reports, general construction-related approvals issued by the German Institute for Construction technology Berlin (e.g. Z-21...) or European Technical Approvals or Assessments (ETA). In general, the usability of construction

products in an EU Member State is given, if the performance of the significant characteristics required in each Member State has been clarified/ confirmed by the manufacturer. Information on the significant necessary characteristics in a country can be found at the national Product Information Contact (Link: <http://ec.europa.eu/Docs-Room/documents/4170/attachments/1/translations/en/renditions/native>).



17

17

Services

Our Service to you	668
Catalogues for other product groups	671
Subsidiaries	674
Importers	676

Our service to you.

„We are a reliable partner, one that will stand at your side and address your individual requirements with advice and action.“

By implementing the fischer process system (fPS) we offer you the quickest and most efficient service.



Global presence with the fischer international sales team

- One-on-one assistance from multi lingual staff.
- Immediate information and individual solutions regarding the widest range of fixings and fasteners worldwide.
- 50 own subsidiaries and distribution to more than 100 countries worldwide.
- Visit organization A - Z and training programs.

Qualified technical consulting from the fischer technical team

- Support for engineers, consultants and craftsmen.
- More than 130 engineers worldwide give legally compliant technical advice and product recommendations.
- Services include test installations, pull-out tests, individual designs and comparative calculations.
- Special solutions in the scope of fixing technology.





Competence and innovation through own research, development and production

- Market research of trends and customer requirements.
- Own research and development teams for chemical, steel and plastic fastenings.
- In-house tool making, special machine construction and production facilities for total process control.
- fischer Process System (FPS) ensures innovative and high quality products.

17

Wide range of fastening and supplementary products for professional and DIY customers

- Comprehensive assortment of chemical, steel and plastic fastenings.
- Supplementary ranges of installation systems, construction chemicals, wood screws, drill bits, facade systems etc.
- Broadest coverage of applications.
- Standard products, project-based solutions and customer-specific developments.





Professional training sessions with the fischer academy

- Wide range of seminars for craftsmen, engineers and specialist dealers.
- Fixing technology at its best based on over 30 years of training experience.
- Theoretical knowledge and practical exercises in line with the demands of the approval.
- Full service programme in modern training rooms, including accomodation.
- Numerous seminar offers online or on site.

17

FiXperience design and construction software for demanding applications

- Design software for planners and structural engineers.
- Modular program including engineering software and application modules.
- Based on international design standards (ETAG 001, EC1, EC2, EC3, EC5), including national application documents.
- Free choice of all common power and measurement units.
- Graphical representation in 3D, 2D, move, 360° rotate, pan, tilt, zoom.

UNDER CONSTRUCTION
Content Will Be Available Soon



Catalogues for other product groups.



Catalogue Installation Systems

All facts about the fischer installation systems and their applications.

- Presentation of products and systems with detailed technical data and illustrations.
- Anchors suitable to fix installation system components.
- Application support.
- Basic knowledge of installation systems.
- Available design software.

→ Order now: info@fischer.com.

Catalogue Screws

All facts about the fischer screw range and their applications.

- Presentation of products with detailed technical data and illustrations.
- Load tables for construction screws.
- Application support.
- Basic knowledge about connections with screws
- Available design software.

→ Order now: info@fischer.com.



International FireStop Handbook

All facts about the fischer FireStop systems and their applications.

- Presentation of products and systems with detailed technical data and accordance to relevant international standards.
- Anchors suitable to fix sprinkler systems.
- Application support.
- Basic knowledge about active and passive fire prevention as well as air and acoustic sealing systems.

→ Order now: info@fischer.com.



Catalogue Façade Systems

All facts about the fischer façade range and their applications.

- Presentation of Zykon panel anchor, machine technology, drill bits, subframes, general fixing products and accessories with detailed technical data and illustrations.
- Application support.
- Basic knowledge about undercut anchors and subframe systems.
- Available design software.

→ Order now: info@fischer.com.



fischer Professional app. The digital solution for the office or the construction site.



Online catalogue

Inform yourself about all fischer products. You will also find relevant technical data and load values.



News

Here you will find all information about fischer - like product innovations or company highlights.



Product advisor

Find the right fixing solution directly to your application.

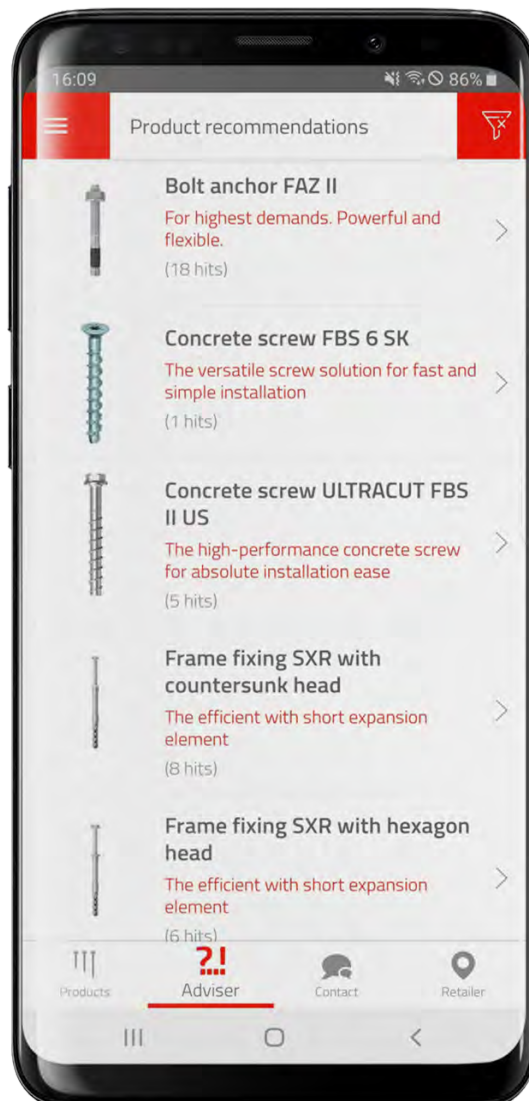

Barcode scanner

Scan your product and you will receive all relevant information. For example, for installation.



Live chat

Benefit in direct contact from the many years of practical experience of the fischer engineers and technicians.



Dealer search

Find the dealer nearest you, which also offers your selected product in the assortment.



from now on in the Google Play & App Store





FiXperience

FiX... e.
calculable.

ers, structural engineers
is modular and can be
program includes an



UNDER CONSTRUCTION
Content will be available soon

17

and balustrades

the injection mortar requirement
the anchors in concrete.

JADE-FIX:
for the design of façade fixing with timber
sub-structure.



All
fischer

Download fischer FiXperience now for free:
www.fischer.de/FiXperience